

# **Southwest ≡ Speed**

**IF YOU DON'T  
BUY FROM US,  
WE BOTH LOSE**

**SAME DAY SHIPPING EVERYDAY  
UNTIL 5:30PM CENTRAL  
MONDAY-FRIDAY**

**(479) 646-6988**

**[www.southwestspeed.com](http://www.southwestspeed.com)**



2 BAR FLOATERS.....	212	BENCH VISES.....	181	CHEVY CRATE FRONT ENGINE KITS.....	54,55
2" DROP SPINDLES, PINTO/MUSTANG II.....	60,65	BERT BELLHOUSINGS.....	139	CHEVY MOTOR & TRANSMISSION MOUNTS.....	78,79
200 MPH TAPE.....	177	BERT TRANSMISSIONS & PARTS.....	144-145	CHROMOLY ROD ENDS.....	51
3RD LINK FRONT MOUNTS.....	216,217	BIG GM BRAKE BRACKETS.....	62,63	CHRYSLER LEAF SPRINGS & PARTS.....	218-220
3RD LINK REAR MOUNTS.....	209	BIG GM BRAKE CALIPERS & PADS.....	68,69	CLAMP BRACKETS.....	175,211
3RD LINK RUBBER TORQUE ABSORBER.....	202	BIG GM BRAKE FLOATERS.....	213,215	CLAMP COLLAR, STEERING SHAFT.....	57
3RD MEMBERS, COMPLETE 9" FORD.....	156	BILLET SPECIALTIES PRODUCTS.....	184,185	CLAMP COLLARS.....	211
3RD MEMBER STORAGE BUCKETS.....	157	BILSTEIN SHOCKS & ACCESSORIES.....	25-28	CLAMP KITS, NYLON & WELDING.....	181
4 BAR FLOATERS & ACCESSORIES.....	212-216	BIRDCAGES / FLOATERS & ACCESSORIES.....	212-216	CLAMP-ON BRAKE BRACKETS.....	63
40 BELOW COOLANT TREATMENT.....	254	BISCUIT TORQUE LINKS, RUBBER.....	202	CLAMP-ON FRAME MOUNTS.....	217
5TH COIL UPPER SHOCK BRACKETS.....	204	BLACK MAGIC LEAF SPRINGS & PARTS.....	218-220	CLAMP-ON STEERING COLUMN MOUNTS.....	58
5x4.75" REAR HUBS, BEARINGS, NUTS, ETC.....	161	BLEEDER KITS.....	135	CLEAR BRAIDED PUSH LOCK HOSE.....	223
5x5" AXLES & AXLE TUBES.....	158,159	BLOCK MOUNT STARTERS & ACCESSORIES.....	130	CLEAR MUD PLUGS.....	163
5x5" REAR HUBS, BEARINGS, NUTS, ETC.....	161	BLOCK PLUG KIT & BLOCK SEALER.....	103,255	CLECO PLIERS & FASTENERS.....	179
5x5" SPINDLES.....	61	BLOWER MOTOR, BRAKE DUCT.....	76	CLEVISSES.....	36
5x5" WHEEL ADAPTERS & SPACERS.....	162,163	BODY / FENDER SUPPORTS.....	182	CLIPBOARDS & STOPWATCHES.....	175
8" WIDE SOUTHWEST SPEED TIRES.....	170	BODY EXHAUST FLANGES.....	248	CLUTCH BALLS & FORKS.....	136
9" FORD 3RD LINK MOUNTS.....	209	BOLT SPACERS, FLAT & TAPERED.....	205	CLUTCH DISCS, STOCK-TYPE.....	131
9" FORD BEARING, RACE, & SEAL KITS.....	156	BOLT-ON BRAKE BRACKETS.....	62	CLUTCH PEDALS & COMBOS.....	72,73,74
9" FORD PINION MOUNTS.....	208	BOOSTERS.....	9	COIL SPRINGS.....	15,16,17
9" FORD REAR ENDS & ACCESSORIES.....	154-156	BOOTS, DRIVING SHOES.....	196	COIL SPRING BUCKETS.....	20
9" FORD RING GEAR BOLT KITS.....	157,251	BOOTS, RACK & PINION.....	57	COIL SPRING RUBBERS.....	16,33
9" FORD SPOOLS.....	157	BOSSSES, BALL JOINT.....	43,61	COIL SPRING SEATS.....	16
9" FORD SPRING BAR MOUNTS.....	204	BOSSSES, WELD-IN THREADED.....	201	COIL SPRING SPACERS.....	16,17,20
9" FORD TORQUE ARMS & ACCESSORIES.....	203,204	BOXES, IGNITION.....	126	COIL SPRING TESTERS.....	175
A-ARMS, LOWER.....	38,39	BRAIDED HOSE, WITH ENDS.....	67	COIL SPRING TORQUE LINKS.....	202
A-ARMS, UPPER.....	35-38	BRAIDED HOSE, -6 AN TO -16 AN.....	223	COILOVER ELIMINATORS.....	32,33
A-ARM BOLT KITS, OEM & RACING.....	250	BRAIDED HOSE ENDS.....	224	COILOVER KITS.....	31
A-ARM BUSHINGS, UPPER & LOWER.....	39,40,41	BRAIDED INSULATING SLEEVING.....	186	COILOVER KIT SHOCK GROOVER.....	31
A-ARM MOUNTS & ADJUSTERS, UPPER.....	34	BRAKE BOOSTERS.....	9	COILOVER KIT SPACERS.....	25
A-ARM PLATES & SHAFTS.....	34	BRAKE BRACKETS.....	62,63	COILOVER SPRINGS.....	15,16
A-ARM SHIMS, UPPER.....	35	BRAKE CALIPERS.....	68,176,177	COILOVER WRENCHES.....	28
ACCUMULATORS & MOUNT KITS.....	86	BRAKE CALIPER BOLTS.....	62,67	COILS, IGNITION.....	125
ACKERMAN ADJUSTERS.....	61	BRAKE CALIPER, PAD, & BRACKET KITS.....	70	COLLAPSIBLE STEERING SHAFTS.....	58
ADEL LINE CLAMPS.....	189,227	BRAKE CRANKS.....	71	COLLECTORS, FLANGES, & GASKETS.....	249
ADJUSTABLE UPPER-ARMS.....	35,37	BRAKE DUCTS, HOSES, & BLOWER MOTOR.....	76,77	COLUMN MOUNTS, STEERING.....	58,201
ADJUSTERS, SWING ARM & TRAILING ARM.....	207	BRAKE FITTINGS.....	76	COMPLETE 9" FORD 3RD MEMBERS.....	156
ADJUSTING SLEEVES, TIE ROD END.....	48	BRAKE FLOATERS.....	213,215	COMPLETE FRONT BRAKE KITS.....	65
AIR CHUCKS, MANIFOLDS, & AIR HOSES.....	180	BRAKE FLUID.....	71,255	COMPLETE FRONT ENGINE KITS.....	54,55
AIR FILTERS / AIR CLEANERS.....	115	BRAKE GAUGE PANELS.....	71,188	CONNECTING RODS.....	101
AIR FILTER HOUSINGS & SURESEALS.....	114	BRAKE HATS & DISC BRAKE KITS.....	66	CONTROL ARMS, LOWER.....	38,39
AIR FILTER OIL.....	115,255	BRAKE LINES, STEEL.....	67	CONTROL ARMS, TUBULAR.....	8
AIR FILTER PRE-FILTERS.....	116	BRAKE LINE TABS.....	201	CONTROL ARMS, UPPER.....	35-38
AIR FILTER STUDS, NUTS, & GASKETS.....	115	BRAKE PADS & PAD SPACERS.....	67,69	CONTROL ARM BUSHINGS.....	39,40,41
AIR GAUGES & AIR TANKS.....	171	BRAKE PEDALS & COMBOS.....	72,73,74	CONTROL ARM MOUNTS & ADJUSTERS.....	34
AIR IMPACT WRENCHES.....	180	BRAKE PROPORTIONING & RESIDUAL VALVES.....	70	CONTROL ARM PLATES & SHAFTS.....	34
AIR RIVETERS & RIVETS.....	178	BRAKE ROTORS.....	63,64,176	CONTROL ARM SHIMS.....	35
AIR TORQUE LINKS.....	202	BRAKE SHUTOFFS.....	70	CONVERSION HATS, DISC BRAKE.....	66
ALCOHOL LUBE.....	254,256	BREATHERS, VALVE COVER & VENT.....	116	COOLING DUCTS & DUCT HOSE.....	196
ALLIED STEEL WHEELS.....	164-169	BREATHER / CRANK CASE PRE-FILTERS.....	116	COOLING FANS.....	120
ALTERNATORS.....	128	BRINN BELLHOUSINGS.....	138	CORVETTE CENTER LINKS.....	44-47
ALTERNATOR MOUNT KITS.....	117,129	BRINN TRANSMISSIONS & PARTS.....	141-143	CORVETTE IDLER ARMS & PITMAN ARMS.....	44-47
ALTERNATOR PULLEYS.....	117,185	BUGGY SEAT BELTS.....	194	CORVETTE TIE ROD ENDS.....	46-48
ALUMINUM AIR TANKS.....	171	BUICK CENTER LINKS.....	44-47	COUPLERS, DIRECT DRIVE.....	140
ALUMINUM COOLING FANS.....	120	BUICK IDLER ARMS & PITMAN ARMS.....	44-47	COUPLERS, STEERING.....	58
ALUMINUM MUD PLUGS, BACK-OF-WHEEL.....	163	BUICK LOWER A-ARMS.....	39	COUPLER BOLT KITS.....	132,138
ALUMINUM POWER STEERING PUMPS.....	52-55	BUICK TIE ROD ENDS.....	46-48	COUPLER CLUTCHES & ACCESSORIES.....	133
ALUMINUM ROD ENDS.....	51	BULKHEAD KITS, FUEL CELL.....	222	CRANKSHAFTS.....	99,100
ALUMINUM SEATS & ACCESSORIES.....	190-193	BUMP STEER GAUGES.....	173	CRANK FLANGE WEIGHTS & ROTATION TOOLS.....	99
ALUMINUM TUBES.....	50	BUMP STEER SPACERS & STUDS.....	49,60	CRANK PULLEYS.....	55,117,185
ALUMINUM WATER PUMPS.....	119	BUMPER MOUNTED BRAKE DUCTS.....	77	CRANK PULLEY ADAPTER, FORD.....	117
ANTI-LOCK BRAKE KIT.....	71	BUNGEE STRAPS.....	181	CRANK PULLEY SPACER & ALIGNMENT BOSS.....	117
ANTI-SEIZE.....	254	BYPASSES, DIAPHRAGM.....	112	CRATE MOTOR FRONT ENGINE KITS.....	54,55
ARM RESTRAINTS.....	193	BYPASSES, THROTTLE.....	104	CREEPER & ROLLER SEAT COMBOS.....	180
ASSEMBLY STAND, ENGINE.....	79	CALIPERS.....	68,176,177	CROSSOVER HEADERS.....	238-240
ATL FUEL CELLS.....	221	CALIPER BOLTS.....	62,67	CTX-2 RACING FUEL ADDITIVE.....	254
AXLES, AXLE TUBES, PLUGS, & BOLTS.....	158,159	CALIPER BRACKETS.....	62,63	CUTLASS CENTER LINKS.....	44-47
BALACLAVAS.....	195	CALIPER FITTINGS.....	76	CUTLASS IDLER ARMS & PITMAN ARMS.....	44-47
BALANCERS & BALANCER PULLER KITS.....	97	CALIPER, PAD, & BRACKET KITS.....	70	CUTLASS LOWER A-ARMS.....	39
BALANCER COUNTER WEIGHT PLATE.....	97	CAMARO CASTER/CAMBER PLATE KIT.....	24	CUTLASS TIE ROD ENDS.....	46-48
BALL JOINTS, UPPER & LOWER.....	42	CAMARO CENTER LINKS.....	44-47	CYLINDER HEADS.....	89,90
BALL JOINT ADAPTER BUSHING.....	43	CAMARO IDLER ARMS & PITMAN ARMS.....	44-47	CYLINDER HEAD BOLT KITS & STUD KITS.....	91
BALL JOINT BOSSSES.....	43,61	CAMARO LEAF SPRINGS & ACCESSORIES.....	218-220	CYLINDER HEAD BUILD KITS.....	91
BALL JOINT HOLDERS.....	36	CAMARO STOCK CLIP HEADERS.....	234	CYLINDER HEAD GASKETS.....	98
BALL JOINT REAMERS, SLEEVES, & SOCKETS.....	43	CAMARO TIE ROD ENDS.....	46-48	DECAL KITS.....	182
BARRY GRANT CARBURETORS & PARTS.....	105-112	CAMARO UPPER A-ARMS.....	38	DELCO ALTERNATORS.....	128
BARRY GRANT FUEL FILTERS.....	114,222	CARB COVERS.....	104	DELUXE GAUGE & PANEL KITS.....	188
BARRY GRANT FUEL LOGS.....	113,223	CARBURETORS & ACCESSORIES.....	105-112	DELUXE PIT KITS.....	171
BATTERY BOXES.....	127,199	CARRERA SHOCKS.....	29,30	DEMOLITION DERBY HEADERS.....	246
BATTERY CABLE & CABLE KITS.....	127,189	CAST IRON POWER STEERING PUMPS.....	52-55	DENSO ALTERNATORS.....	128
BATTERY DISCONNECTS.....	126,188	CASTER/CAMBER GAUGES.....	173	DETROIT LOCKERS.....	157
BATTERY TERMINAL ENDS & END BOOTS.....	127	CASTER/CAMBER PLATE KIT, CAMARO.....	24	DIAMOND TRACKS.....	157
BATTERY TERMINALS & TERMINAL BLOCKS.....	189	CAVALIER STYLE ROOFS.....	183	DIAPHRAGM BYPASSES.....	112
BEAD BREAKERS.....	169	CENTER LINKS.....	44	DIPSTICKS.....	85
BEADLOCK WHEELS.....	165-169	CHANNEL TABS.....	201	DIRECT DRIVE COUPLERS.....	140
BEARING GAS PEDALS.....	75,104	CHASSIS HEADERS.....	237	DIRECT DRIVE TANDEM PUMPS.....	56
BEARING KITS, STOCK FRONT HUB & ROTOR.....	66	CHASSIS HEIGHT CHECKERS.....	175	DISC BRAKE HATS & DISC BRAKE KITS.....	66
BEARING, RACE, & SEAL KITS, 9" FORD.....	156	CHEVELLE CENTER LINKS.....	44-47	DISC BRAKE RESIDUAL VALVES.....	70
BELLHOUSINGS & PARTS.....	137-139	CHEVELLE IDLER ARMS & PITMAN ARMS.....	44-47	DISCONNECTS, BATTERY.....	126,188
BELT DRIVE FUEL PUMPS & DRIVE KITS.....	113	CHEVELLE LOWER A-ARMS.....	39	DISCONNECTS, STEERING.....	59
BELT DRIVE TANDEM PUMPS.....	56	CHEVELLE TIE ROD ENDS.....	46-48	DISTRIBUTORS & ACCESSORIES.....	122-125
BELTS, V-BELT & SERPENTINE.....	120	CHEVELLE UPPER A-ARMS.....	37,38	DODGE POWER STEERING BRACKETS.....	53



DODGE SERPENTINE PULLEY KITS.....	53	FRESH AIR SYSTEMS.....	196	HEADER WRAP.....	186,249
DOT 3 BRAKE FLUID.....	71,255	FRONT AXLES, OPEN WHEEL.....	14	HEI DISTRIBUTORS.....	122
DOUBLE SPLINED AXLES.....	158	FRONT BRAKE BRACKETS.....	62	HEIM ENDS.....	51
DOWEL PINS.....	139	FRONT BRAKE KITS.....	65	HEIM END REDUCERS.....	205
DRAG LINKS.....	44	FRONT ENGINE KITS.....	54,55,184	HELMET HOOKS.....	186
DRAG RACING FUEL CELLS.....	221	FRONT HUBS & ROTORS.....	64	HELMET RESTRAINTS.....	193
DRAG RACING TIRE TREATMENT.....	253	FRONT HUB, ROTOR, & SPINDLE KITS.....	65	HELMET SUPPORTS.....	195
DRILL BITS, WHEEL STUD.....	162	FRONT HUB BEARING KITS.....	66	HIDDEN WEIGHT JACKS.....	17,20
DRILL PRESS VISES.....	181	FRONT SPRINGS.....	15,16,17	HOOD PINS & ACCESSORIES.....	182
DRIVE KITS & PARTS.....	82,83	FUEL ADDITIVE.....	254,256	HOSE, COOLING DUCT.....	76,196
DRIVESHAFTS & DRIVESHAFT LOOPS.....	149	FUEL CELLS, FOAM, JUGS, & FUNNELS.....	221,222	HOSE, PUSH LOCK & BRAIDED.....	223
DRIVESHAFT U-BOLTS & GIRDLES.....	150	FUEL CELL CAPS, FLANGES, & GASKETS.....	221	HOSE, STEEL BRAIDED, WITH ENDS.....	67
DRIVESHAFT YOKES & U-JOINTS.....	150	FUEL FILTERS & BRACKETS.....	114,222	HOSE CLAMPS.....	227
DRIVING UNIFORMS, GLOVES, BOOTS.....	195,196	FUEL FRAGRANCE.....	256	HOSE ENDS, PUSH LOCK & BRAIDED.....	224
DROP SPINDLES, PINTO/MUSTANG II.....	60,65	FUEL LOGS.....	113,223	HOSE KITS, POWER STEERING.....	56
DRUM BRAKE RESIDUAL VALVES.....	70	FUEL PRESSURE GAUGES.....	187	HOT LAP TIRE SOFTENER.....	253
DRY SUMP PUMPS & PARTS.....	80,81,82	FUEL PRESSURE REGULATORS.....	112	HOT ROD FRONT HUBS & ROTORS.....	64
DRY SUMP PUMP DRIVE KITS & PARTS.....	82,83	FUEL PUMPS, ELECTRIC & MECHANICAL.....	112,113	HOT ROD HUB, ROTOR, & SPINDLE KITS.....	65
DRY SUMP TANKS.....	83	FUEL PUMPS, TANDEM.....	56	HUBS & ROTORS, STOCK FRONT.....	64
DUCTS, BUMPER & WINDOW MOUNTED.....	77	FUEL PUMP DRIVE KITS & PARTS.....	113	HUBS & ROTORS BEARING KITS, STOCK FRONT.....	66
DUROMETERS & TREAD DEPTH GAUGES.....	172	FUEL PUMP MOUNTS & BLOCK-OFF PLATES.....	113	HUBS, ROTORS, & SPINDLES KITS, STOCK FR.....	65
DUST COVERS.....	64,160	FULL CONTAINMENT ADD-ON RESTRAINT KITS.....	191	HUBS, WIDE 5 & 5x5" RACING-TYPE.....	160,161
DYNALITE BRAKE BRACKETS.....	62,63	FULL CONTAINMENT KIRKEY SEATS.....	192	HYDRAULIC LIFTERS.....	95
DYNALITE BRAKE CALIPERS & PADS.....	68,69	FULL SPOOLS.....	157	HYDRAULIC THROWOUT BEARINGS.....	135,136
DYNALITE BRAKE FLOATERS.....	213,215	FUNNELS, FUEL.....	222	IDLER ARMS.....	44
DZUS FASTENERS.....	179	GAS PEDALS.....	75,104	IDLER ARM BOLT KITS, OEM & RACING.....	250
EL CAMINO CENTER LINKS.....	44-47	GASKETS, FULL ENGINE KITS.....	98	IGNITION BOXES & COILS.....	125,126
EL CAMINO IDLER ARMS & PITMAN ARMS.....	44-47	GASKETS, HEADER.....	248	IMPACT WRENCHES.....	180
EL CAMINO LOWER A-ARMS.....	39	GASKETS, OIL PAN.....	84	IMPALA CENTER LINKS.....	44-47
EL CAMINO TIE ROD ENDS.....	46-48	GAUGES, GAUGE PANELS, & ACC.....	187-189	IMPALA IDLER ARMS & PITMAN ARMS.....	44-47
ELASTIC DAMPERS.....	97	GAUGE FITTINGS.....	76	IMPALA TIE ROD ENDS.....	46-48
ELBOWS, EXHAUST.....	247	GAUGE LINE KITS.....	187	INLINE FUEL FILTERS & BRACKETS.....	114,222
ELECTRIC BRAKE SHUTOFFS.....	70	GEAR LUBE.....	253	INNER TIE ROD ENDS.....	48,49
ELECTRIC COOLING FANS.....	120	GEAR OIL.....	159,255	INSTALLATION KITS, WINDOW NET.....	198
ELECTRIC FUEL PUMPS.....	112,113	GEAR STORAGE BUCKETS.....	157	INSULATING FLOOR MATS.....	186
ELECTRIC WATER PUMPS.....	119	GIFT CERTIFICATES.....	259	INTAKE COVER.....	103
ELECTRONIC REV LIMITERS.....	126	GIRDLES, DRIVESHAFT.....	150	INTAKE MANIFOLDS.....	91
ELECTRONIC SCALES & ACCESSORIES.....	174	GIRLING TYPE MASTER CYLINDERS.....	74	JACK STANDS.....	177
ELECTRONIC SPRING TESTERS.....	175	GM CALIPER BOLTS.....	62,67	JAM NUTS.....	51
ELIMINATORS, COILOVER.....	32,33	GM III BRAKE CALIPERS.....	68	J-BARS.....	206
EMERGENCY BRAKE CALIPERS.....	68	GM METRIC BRAKE BRACKETS.....	62,63	J-BENDS & U-BENDS, EXHAUST.....	248
ENGINE ACCESSORIES & PARTS.....	89-103	GM METRIC BRAKE CALIPERS.....	68,70,65	JUGS, FUEL.....	222
ENGINE ASSEMBLY STANDS & ENGINE BAGS.....	79	GM METRIC BRAKE FLOATERS.....	213,215	K&W BLOCK SEALER.....	103,255
ENGINE BLOCK PLUG KITS & SEALER.....	103,255	GM METRIC BRAKE PADS.....	69,70	KARTING BRAKE CALIPERS.....	177
ENGINE CRADLES.....	79,99	GM METRIC CALIPER, PAD, & BRACKET KITS.....	70	KARTING MASTER CYLINDERS.....	177
ENGINE GASKET KITS.....	98	GM METRIC DISC BRAKE KITS.....	66	KIRKEY SEATS & ACCESSORIES.....	190-193
ENGINE LIFT PLATE & INTAKE COVER.....	103	GM METRIC HUBS & ROTORS.....	64	KONI SHOCKS & ACCESSORIES.....	28
ENGINE LOAD LEVELER.....	103	GM METRIC HUB BEARING KITS.....	66	KRC POWER STEERING PRODUCTS.....	53,54,55
ENGINE TOP DEAD CENTER LOCATOR.....	103	GM METRIC REAR END MOUNTS, STOCK.....	210	KSE TANDEM X PUMPS.....	56
EXHAUST FLANGES.....	248	GM METRIC SPINDLE SAVERS.....	61	LAMINATED TEAROFFS.....	197
EXHAUST HEADERS & ACCESSORIES.....	228-249	GM METRIC STOCK CLIP HEADERS.....	234	LASER STRING TOOLS.....	173
EXTENSIONS, EXHAUST.....	248	GM METRIC UPPER A-ARMS.....	38	LATE MODEL HEADERS, DIRT.....	241-243
FALCON BELLHOUSINGS.....	139	GM ROLL CAGE KITS.....	199	LEAD WEIGHT.....	175
FALCON TRANSMISSIONS & PARTS.....	146-147	GM SPOOLS, FULL & MINI.....	157	LEAF SPRINGS, BUSHINGS, MOUNTS, ETC.....	218-220
FANS, COOLING.....	120	GO-KART BRAKE CALIPERS.....	177	LEG RESTS, EXTENSIONS, & PROTECTORS.....	193
FAN SHROUDS, SPACERS, & BELTS.....	120	GO-KART MASTER CYLINDERS.....	177	LEMANS CENTER LINKS.....	44-47
FASTENERS, CLECO & DZUS.....	179	GP310 BRAKE CALIPERS.....	176	LEMANS IDLER ARMS & PITMAN ARMS.....	44-47
FENDER / BODY SUPPORTS.....	182	GRANADA HUBS, ROTORS, & BEARING KITS.....	64-66	LEMANS LOWER A-ARMS.....	39
FIBERGLASS ROOFS.....	183	GRAND NATIONAL BRAKE PADS.....	69	LEMANS TIE ROD ENDS.....	46-48
FIRE BRAIDED SLEEVING.....	186	GRAND PRIX CENTER LINKS.....	44-47	LEVELERS, SCALE PAD.....	174
FIREBIRD CENTER LINKS.....	44-47	GRAND PRIX IDLER & PITMAN ARMS.....	44-47	LEXAN SPOILERS.....	183
FIREBIRD IDLER ARMS & PITMAN ARMS.....	44-47	GRAND PRIX LOWER A-ARMS.....	39	LIFT PLATE, ENGINE.....	103
FIREBIRD TIE ROD ENDS.....	46-48	GRAND PRIX TIE ROD ENDS.....	46-48	LIFTER VALLEY BAFFLE.....	91
FITTING WRENCHES, -AN TYPE.....	227	GREASE, WHEEL BEARING.....	160	LIFTERS.....	95
FITTINGS, -AN TYPE.....	224-227	GREMLIN STYLE ROOFS.....	183	LIGHTWEIGHT STEERING QUICKNERS.....	59
FITTINGS, POWER STEERING PUMP & BOX.....	56	GRIFFIN RADIATORS.....	121	LINE CLAMPS, ADEL.....	189,227
FIXED STEERING SHAFTS.....	58	GRINDING DISCS, TIRE.....	171	LINE FITTINGS.....	76
FLANGED STEERING BEARINGS.....	57	GROOVER, SHOCK.....	31	LINE KITS, GAUGE.....	187
FLANGES, EXHAUST.....	248	GROOVERS, TIRE.....	170	LINE KITS, NYLON.....	67
FLAT BOLT SPACERS.....	205	GTO CENTER LINKS.....	44-47	LINES, STEEL BRAIDED.....	67
FLEXPLATES & FLEXPLATE BOLT KITS.....	132	GTO IDLER ARMS & PITMAN ARMS.....	44-47	LINKAGES, THROTTLE.....	103
FLOATERS / BIRDCAVES & ACC.....	212-216	GTO LOWER A-ARMS.....	39	LOAD LEVELER.....	103
FLOATERS, BRAKE.....	213,215	GTO TIE ROD ENDS.....	46-48	LOGS, FUEL.....	113,223
FLOATERS, LEAF SPRING.....	219	GUIDE PLATES.....	93	LOWER A-ARMS.....	38,39
FLOATERS, SWING ARM.....	207	GUN-DRILLED AXLES.....	158	LOWER A-ARM BOLT KITS, OEM & RACING.....	250
FLOATER LOCKS, RINGS, & LINERS.....	216	GUN-DRILLED STEEL ROD ENDS.....	51	LOWER A-ARM BUSHINGS.....	39,40,41
FLOATER ROLLER BEARINGS.....	215	GUSSETS & TUBE PLUGS.....	199	LOWER A-ARM STRUT BARS.....	39
FLOOR MATS.....	186	HALOGEN WORK LIGHTS.....	181	LOWER BALL JOINTS & MONO BALL JOINTS.....	42
FLOW TOP AIR FILTER & HOUSING.....	115	HAND RIVETERS & RIVET SPACERS.....	179	LOWER SPOILERS & NOSEPIECES.....	183
FLUID DAMPERS.....	97	HANDLEBAR MASTER CYLINDERS.....	176	LOWERING BLOCKS.....	219
FLYWHEELS, BRINN/BERT/FALCON.....	140	HARLEY BRAKE CALIPERS & ROTORS.....	176	LUG NUTS.....	162
FLYWHEELS, STOCK-TYPE.....	131	HARMONIC BALANCERS.....	97	LUG WRENCHES.....	162,171
FLYWHEEL / FLEXPLATE SHIMS.....	133,138	HARNES PADS.....	194	LUMBAR SUPPORTS.....	193
FLYWHEEL BOLT KITS.....	132,138	HATS, DISC BRAKE.....	66	MAG 1 PRODUCTS.....	255
FOOT MASTER CYLINDERS.....	176	HEAD & SHOULDER ADD-ON RESTRAINT KITS.....	191	MAIN CAPS, GIRDLES, AND STUD & BOLT KITS.....	98
FORD CRANK PULLEY ADAPTER.....	117	HEADS, ALUMINUM & CAST IRON.....	89,90	MALIBU CENTER LINKS.....	44-47
FORD MOTOR MOUNTS.....	79	HEAD BOLT KITS & STUD KITS.....	91	MALIBU IDLER ARMS & PITMAN ARMS.....	44-47
FORD POWER STEERING BRACKETS.....	52,53	HEAD BUILD KITS.....	91	MALIBU LOWER A-ARMS.....	39
FORD POWER STEERING PUMP KITS.....	54	HEAD GASKETS.....	98	MALIBU TIE ROD ENDS.....	46-48
FORD SERPENTINE PULLEY KITS.....	53	HEAD RESTS.....	191	MANIFOLDS.....	91
FRAME MOUNTS, WELD-ON & CLAMP-ON.....	216,217	HEAD SOCKS.....	195	MANUAL BRAKE SHUTOFFS.....	70
FRAME PLATES, WEIGHT JACK.....	20	HEADERS & ACCESSORIES.....	228-249	MANUAL RACK & PINIONS.....	57



MASTER BATTERY DISCONNECTS.....	126,188	OUTLAW FIBERGLASS ROOFS.....	183	READY-TO-RUN DISTRIBUTORS.....	123,124
MASTER CYLINDERS.....	74,75,176,177	OVERSIZED STEERING ROD ENDS.....	51,57	REAMERS, BALL JOINT.....	43
MASTER CYLINDER FITTINGS.....	76	OVER-THE-TOP PRE-FILTERS.....	116	REAR DISC BRAKE KITS.....	66
MCP BRAKE PRODUCTS.....	177	PADDING, ROLL BAR.....	178,186	REAR ENDS & ACCESSORIES.....	151-159
MECHANICAL FUEL PUMPS.....	112	PADS & PAD SPACERS, BRAKE.....	67,69	REAR SPRINGS.....	15,16,17
MECHANICAL LIFTERS.....	95	PADS, LEAF SPRING.....	219	REAR VIEW MIRRORS.....	186
MECHANICAL THROWOUT BEARINGS.....	136	PANEL CLIPS.....	179	REDUCERS, EXHAUST.....	247
MESH WINDOW NETS.....	198	PANHARD BARS.....	206	REDUCERS, ROD END.....	205
METRIC BRAKE BRACKETS.....	62,63	PANHARD BAR FRAME MOUNTS.....	216,217	REDUCERS, STEERING.....	59
METRIC BRAKE CALIPERS.....	68,70,65	PANHARD BAR PINION MOUNTS.....	208	REGULATORS, FUEL PRESSURE.....	112
METRIC BRAKE FLOATERS.....	213,215	PANHARD BAR REAR END TUBE MOUNTS.....	207	REMOTE BLEEDER KITS.....	135
METRIC BRAKE PADS.....	69,70	PAPER AIR FILTERS.....	115	REMOTE RESERVOIR MASTER CYLINDERS.....	74,75
METRIC CALIPER, PAD, & BRACKET KITS.....	70	PEDALS, BRAKE & CLUTCH.....	72,73,74	RESERVOIRS, POWER STEERING.....	52,53
METRIC DISC BRAKE KITS.....	66	PEDALS, GAS.....	75,104	RESIDUAL VALVES.....	70
METRIC HUBS & ROTORS.....	64	PEDAL MOUNTS, BRAKE & CLUTCH.....	74	RESTORATION FRONT HUBS & ROTORS.....	64
METRIC HUB BEARING KITS.....	66	PENETRATING OIL.....	255	RESTORATION HUB, ROTOR, & SPINDLE KITS.....	65
METRIC REAR END MOUNTS, STOCK.....	210	PIGTAIL SPRINGS.....	17	RESTRAINT KITS, ADD-ON HEAD & SHLDER.....	191
METRIC SPINDLE SAVERS.....	61	PILOT BUSHINGS.....	139	RESTRICTOR KITS, WATER OUTLET.....	119
METRIC STOCK CLIP HEADERS.....	234	PINION MOUNTS, 9" FORD & QUICK CHANGE.....	208	RETAINER RINGS.....	216
METRIC UPPER A-ARMS.....	38	PINTO HEADERS.....	246	RETAINERS, VALVE SPRING.....	93
MICRO-SPRINT BRAKES.....	177	PINTO LEAF SPRINGS & ACCESSORIES.....	218-220	REV LIMITERS.....	126
MICRO-SPRINT CHASSIS & PARTS.....	14	PINTO SPINDLES & KITS.....	60,65	REVERSE MOUNT STARTERS & ACCESSORIES.....	130
MICRO-SPRINT SPROCKETS.....	177	PINTO SPINDLE/METRIC BRAKE BRACKETS.....	62,65	RIBBON WINDOW NETS.....	198
MIDGET CHASSIS & PARTS.....	14	PISTONS & PISTON RINGS.....	101,102	RING & PINION INSTALL KITS, 9" FORD.....	156
MIDGET / SPRINT LEG PROTECTORS.....	193	PIT KITS, DELUXE.....	171	RING & PINIONS, 9" FORD & CHEVY.....	156
MID-PLATES.....	77,78	PIT MATS.....	171,177	RING & PINIONS, QUICK CHANGE.....	151
MINI-BRAKE GAUGE PANELS.....	71,188	PITMAN ARMS.....	45	RING GEAR BOLT KITS.....	251
MINI-CLUTCHES & ACCESSORIES.....	133-135	PLASTIC COOLING FANS.....	120	RIVETS & RIVETERS.....	178,179
MINI-SPOOLS.....	157	PLASTIC, ROLL.....	179	RJS UNIFORMS, GLOVES, BOOTS, ETC.....	195,196
MINI-STARTERS & ACCESSORIES.....	130	PLIERS, CLECO & SAFETY WIRE.....	179	ROBIC STOPWATCHES & CLIPBOARDS.....	175
MINI-STARTER BOLT KITS.....	250	PLUG WIRES.....	126	ROCK CRAWLING TIRE TREATMENT.....	253
MINI-STOCK WHEELS.....	168	POLISHED PULLEYS.....	184,185	ROCKER ARMS & ROCKER ARM STUDS.....	93,94
MIRRORS.....	186	POLY-LOCKS.....	93	ROD ENDS.....	51
MODIFIED CENTER LINKS & IDLER ARMS.....	44	POLYMATRIX BRAKE PADS.....	69	ROD ENDS WITH A-ARM ADAPTERS.....	38
MODIFIED FRONT HUBS & ROTORS.....	64,65	PONTIAC CENTER LINKS.....	44-47	ROD END REDUCERS.....	205
MODIFIED FRONT HUB BEARING KITS.....	66	PONTIAC IDLER ARMS & PITMAN ARMS.....	44-47	RODS, H-BEAM & I-BEAM.....	101
MODIFIED HEADERS.....	228-233	PONTIAC LOWER A-ARMS.....	39	ROLL BAR PADDING.....	178,186
MODIFIED HUB, ROTOR, & SPINDLE KITS.....	65	PONTIAC TIE ROD ENDS.....	46-48	ROLL CAGE KITS.....	199
MODIFIED PITMAN ARMS.....	45	POP RIVETS & RIVETERS.....	178,179	ROLL PLASTIC.....	179
MODIFIED SPINDLES & KITS.....	60,65	PORTA POWERS.....	182	ROLLER BEARINGS, FLOATER.....	215
MODIFIED TIE ROD ENDS.....	48,49	POWER BRAKE BOOSTERS.....	9	ROLLER LIFTERS.....	95
MODIFIED UPPER A-ARMS.....	35-38	POWER RACK & PINIONS.....	57	ROLLER ROCKERS.....	94
MONO BALL JOINTS, UPPER & LOWER.....	42	POWER STEERING BOXES.....	58	ROLLER SEAT & CREEPER COMBOS.....	180
MONO BALL JOINT LOWER A-ARMS.....	38	POWER STEERING BRACKETS.....	52,53	ROLLOVER VALVE, FUEL CELL.....	222
MONO BALLS & MONO BALL STUDS.....	43	POWER STEERING FITTINGS, BOX & PUMP.....	56	RONDEL VINYL SHELF MAT.....	177
MONTE CARLO CENTER LINKS.....	44-47	POWER STEERING FLUID & LUBE.....	56	ROOFS, FIBERGLASS.....	183
MONTE CARLO IDLER & PITMAN ARMS.....	44-47	POWER STEERING HOSE KITS.....	56,185	ROTOR, HUB, & SPINDLE KITS.....	65
MONTE CARLO LOWER A-ARMS.....	39	POWER STEERING PUMPS & KITS.....	52-55,184	ROTORS, BRAKE.....	63,64
MOOSE BLOCKS, SETUP TOOLS.....	175	POWER STEERING TANKS.....	52,53,185	ROTOR BOLT KITS.....	63,66
MOTOR MOUNTS.....	78,79	POWERGLIDE COUPLERS, DIRECT DRIVE.....	140	RUBBER A-ARM BUSHINGS.....	39,40,41
MOTOR OIL.....	103,255	PREMIER UPPER A-ARMS.....	35	RUBBER BUNGEE STRAPS.....	181
MOTOR PLATES.....	77,78	PRESSURE PLATES, STOCK-TYPE.....	131	RUBBER BUSHING J-BARS.....	206
MOTORCOACHES & MOTORHOMES.....	257,258	PRESSURE PLATE BOLT KITS.....	251	RUBBER BUSHING TRAILING ARM MOUNTS.....	51
MOTORCYCLE BRAKES.....	176	PRO SHOCKS & ACCESSORIES.....	21-24	RUBBER POWER STEERING HOSE.....	56
MOTORCYCLE SPROCKETS.....	177	PRO-BLEND PRODUCTS.....	253,254	RUBBER SNUBBER BARS.....	202
MOUNTING BRACKETS, POWER STEERING.....	52,53	PROGRESSIVE SPRINGS.....	15	RUBBER SPRING TORQUE LINKS.....	202
MOUNTING TABS, SEAT.....	190	PROPORTIONING VALVES.....	70	RUBBER TORQUE LINK SPRINGS.....	203
MOUNTING TABS, WELD-ON.....	200,201	PULLEYS, ALTERNATOR.....	117,185	SAFETY WIRE & SAFETY WIRE PLIERS.....	179
MUD PLUGS.....	163	PULLEYS, CRANK & WATER PUMP.....	55,117,185	SCALES SYSTEMS & ACCESSORIES.....	174
MUFFLERS.....	247	PULLEYS, POWER STEERING.....	52-55,185	SCHOENFELD HEADERS & ACCESSORIES.....	228-249
MUSTANG CENTER LINKS.....	44-47	PUSH LOCK HOSE & HOSE ENDS.....	223,224	SCRUB BAGS.....	116
MUSTANG IDLER ARMS & PITMAN ARMS.....	44-47	PUSH RODS.....	95	SCS GEARBOX INC. QUICK CHANGE GEARS.....	153
MUSTANG II SPINDLES & KITS.....	60,65	PYROMETERS.....	174	SEATS & ACCESSORIES.....	190-193
MUSTANG II SPINDLE/METRIC BRAKE BRKTS.....	62,65	QUARTER MASTER BELLHOUSINGS & ACC.....	137,138	SEAT BELTS & HARDWARE.....	194
MUSTANG ROLL CAGE KITS.....	199	QUARTER MASTER MINI-CLUTCHES & PARTS.....	134	SELF-EJECTING DZUS FASTENERS.....	179
MUSTANG TIE ROD ENDS.....	46-48	QUICK CHANGE 3RD LINK MOUNTS.....	209	SEMI-METALLIC BRAKE PADS.....	69
NARROW DYNALITE BRAKE CALIPERS & PADS.....	68,69	QUICK CHANGE PINION MOUNTS.....	208	SERPENTINE FAN BELTS.....	120
NECK BRACES.....	195	QUICK CHANGE POWER STEERING BRKT.....	53	SERPENTINE PULLEY KITS.....	53-55,184-185
NEEDLE BEARING GAS PEDALS.....	75,104	QUICK CHANGE REAR ENDS & PARTS.....	151-153	SHACKLE KITS, LEAF SPRING.....	220
NITRILE / TEFLON FLOATER LINERS.....	216	QUICK CHANGE RING & PINIONS.....	151	SHAFT MOUNT ROLLER ROCKERS.....	94
NOMEX UNDERWEAR, HEAD SOCKS, & SOCKS.....	195	QUICK CHANGE RING GEAR BOLTS KITS.....	251	SHELF MAT, RONDEL VINYL.....	177
NOSEPIECES.....	183	QUICK CHANGE SPOOLS.....	157	SHIFTERS & ACCESSORIES.....	148
NYLOCK JAM NUTS.....	51	QUICK CHANGE SPRING BAR MOUNTS.....	204	SHOCKS, BILSTEIN.....	25-28
NYLON A-ARM BUSHINGS.....	39,40,41	QUICK CHANGE SPUR GEARS.....	153	SHOCKS, CARRERA.....	29,30
NYLON CLAMP KITS.....	181	QUICK CHANGE TORQUE ARMS & PARTS.....	203,204	SHOCKS, PRO.....	21-24
NYLON LINE KITS.....	67	QUICK DISCONNECTS.....	59	SHOCK EXTENSIONS.....	21
NYLON WIRE TIES.....	178	QUICK STEERS & MOUNTS.....	59	SHOCK MOUNTS, WELD-ON.....	32
OCTANE BOOST.....	254	RACING ALTERNATOR MOUNT KITS.....	129	SHOCK MOUNTS, CLAMP-ON.....	211
OIL FILTERS, MOUNTS, & BYPASS PLATES.....	85	RACING FRONT HUBS & ROTORS.....	64	SHOCK MOUNTS, SWIVELING.....	215
OIL FILTER CUTTERS.....	85	RACING FRONT HUB BEARING KITS.....	66	SHOCK MOUNTS, TIE ROD END.....	28
OIL FILTER ROCK GUARDS & COOLERS.....	85	RACING FUEL ADDITIVE.....	254,256	SHOCK PINS & SPACERS.....	30
OIL PANS & PICKUPS.....	84	RACING HUB, ROTOR, & SPINDLE KITS.....	65	SHOCK VALVES & VALVING MANUALS.....	27
OIL PAN RAIL GIRDLES & GASKETS.....	84	RACING OPTICS TEAROFFS.....	197	SHOCKWEARS.....	25
OIL PRESSURE & TEMPERATURE GAUGES.....	187	RACING TRAILERS.....	258	SHOES, DRIVING BOOTS.....	196
OIL PUMPS, STUD KITS, & PRIMERS.....	86	RACING UNIFORMS, GLOVES, & BOOTS.....	195,196	SHOP TOWELS.....	182
OIL PUMPS, DRY SUMP.....	80	RACK & PINIONS.....	57	SHORT BARS.....	50
OLDSMOBILE CENTER LINKS.....	44-47	RADIATORS, CAPS, MOUNTS, REPAIR KITS.....	121	SHOULDER SUPPORTS.....	191
OLDSMOBILE IDLER & PITMAN ARMS.....	44-47	RADIUS ROD BRACKETS.....	216	SHROUDS, FAN.....	120
OLDSMOBILE LOWER A-ARMS.....	39	RAM MINI-CLUTCHES & PARTS.....	133	SIPERS, TIRE.....	170
OLDSMOBILE TIE ROD ENDS.....	46-48	RAMPS, SCALE PAD.....	174	SLAVE CYLINDERS.....	75
OUTER TIE ROD ENDS.....	48,49	RATCHET TIE-DOWNS.....	181	SLEEVES, BALL JOINT.....	43
OUTERWEAR PRE-FILTERS.....	116	RCI FUEL CELLS, JUGS, & FUNNELS.....	221,222	SLIDERS, COILOVER ELIMINATORS.....	32,33



SLIDERS, LEAF SPRING.....	220	STREET STOCK HEADERS.....	235,236	TRANSMISSION TREATMENT.....	254
SMALL RUBBER BISCUIT TORQUE LINKS.....	202	STREET STOCK SHOCKS & STRUTS.....	24-29	TREAD DEPTH GAUGES.....	172
SNOUT & AXLE SEALS.....	159	STRUT BARS.....	39	TRIPLE X CHASSIS & PARTS.....	14
SNOUTS, REAR END.....	159	STUD GIRDLE KITS.....	93	TRUCK / TRACTOR PULL HEADERS.....	246
SNOUTS, SPINDLE.....	61	STUDDED ROD ENDS.....	51	TUBE & AXLE SEALS.....	159
SNUBBER BARS.....	202	SUITS, RACING UNIFORMS.....	195	TUBE PLUGS & GUSSETS.....	199
SOCKETS, BALL JOINT.....	43	SUPERLITE BRAKE BRACKETS.....	62,63	TUBULAR STEERING SHAFTS.....	58
SOCKS, NOMEX.....	195	SUPERLITE BRAKE CALIPERS & PADS.....	68,69	TUBULAR UPPER & LOWER A-ARMS.....	8,35-38
SOLID AXLES.....	158	SUPERLITE BRAKE FLOATERS.....	213,215	TURNING PLATES.....	173
SOLID J-BARS.....	206	SURESEALS.....	114	TURNOUTS, EXHAUST.....	247
SOLID LIFTERS.....	95	SUSPENSION REAMERS.....	43	U-BENDS & J-BENDS, EXHAUST.....	248
SOLID MOTOR & TRANSMISSION MOUNTS.....	78	SWABBYS, SHOP TOWELS.....	182	U-BOLTS, DRIVESHAFT.....	150
SOLID ROD ENDS.....	51	SWAY BARS & ACCESSORIES.....	49	U-BOLTS, LEAF SPRING.....	220
SOUTHWEST SPEED RACING TIRES.....	170	SWEDGED STEEL TUBES.....	50	U-DESIGN-IT FLOATERS.....	212
SPACERS, BRAKE PAD.....	67	SWING ARMS & SWING ARM ADJUSTERS.....	207	U-JOINTS, DRIVESHAFT.....	150
SPACERS, FLAT & TAPERED BOLT.....	205	SWING ARM FLOATERS, Z-LINK.....	207,212	U-JOINTS, STEERING.....	58
SPANNER WRENCHES.....	28	SWING ARM FRONT MOUNTS.....	216,217	UNDERWEAR, NOMEX.....	195
SPARK PLUG WIRES.....	126	SWITCH PANELS & ACCESSORIES.....	187,188	UNIFORMS, RJS.....	195
SPEEDY LUG WRENCHES.....	162,171	SWIVELING SHOCK MOUNTS.....	215	UNIVERSAL CLAMP BRACKETS & COLLARS.....	211
SPINDLES.....	60,61	T-SHIRTS.....	259	UPPER A-ARMS.....	35-38
SPINDLE, HUB, & ROTOR KITS.....	65	TABS, WELD-ON.....	200,201	UPPER A-ARM BOLT KITS.....	250
SPINDLE BOSSES.....	43,61	TACHOMETERS.....	188	UPPER A-ARM BUSHINGS.....	39,40,41
SPINDLE NUTS & NUT WRENCHES.....	160,161	TANDEM MASTER CYLINDERS.....	9	UPPER A-ARM MOUNTS & ADJUSTERS.....	34
SPINDLE REAMERS.....	43	TANDEM PUMPS, P.S. & FUEL.....	56	UPPER A-ARM PLATES & SHAFTS.....	34
SPINDLE SAVERS, GM METRIC.....	61	TANDEM PUMPS, P.S., FUEL, & OIL.....	80	UPPER A-ARM SHIMS.....	35
SPINDLE SNOUTS.....	61	TANDEM PUMP ADAPTERS.....	56	UPPER BALL JOINTS & MONO BALL JOINTS.....	42
SPLINED STEERING DISCONNECTS.....	59	TANDEM X PUMPS, KSE.....	56	UPPER SHOCK BRACKET, 5TH COIL.....	204
SPOILERS, LEXAN & LOWER.....	183	TANKS, ALUMINUM AIR.....	171	UPPER SHOCK MOUNTS, 90/10.....	209
SPOOLS, FULL & MINI.....	157	TANKS, POWER STEERING.....	52,53	VALVE COVERS.....	87,88
SPOT MIRRORS.....	186	TAPE MEASURES.....	171	VALVE COVER BREATHERS.....	116
SPRINGS, COILOVER.....	15,16	TAPE, 200 MPH.....	177	VALVE COVER GASKETS & HOLD DOWNS.....	88
SPRINGS, CONVENTIONAL.....	16,17	TAPERED BOLT SPACERS.....	205	VALVE COVER STUDS & NUTS.....	86
SPRINGS, EXTRA CLEARANCE.....	16	TEAROFFS & BUTTONS.....	197	VALVES & VALVE SPRINGS.....	92
SPRINGS, PIGTAIL.....	17	TEFLON / NITRILE FLOATER LINERS.....	216	VALVE SPRING RETAINERS, SEATS, & SHIMS.....	93
SPRINGS, PROGRESSIVE.....	15	TELESCOPING STEERING SHAFTS.....	58	VALVE STEMS & VALVE STEM TOOLS.....	169
SPRINGS, TORQUE-LINK, COIL.....	16	TERMINAL ENDS & END BOOTS.....	127	VAN ALSTINE TIRE GROOVERS & SIPERS.....	170
SPRINGS, TORQUE LINK, RUBBER.....	203	TERMINALS & TERMINAL BLOCKS.....	189	V-BELT FAN BELTS.....	120
SPRING BARS & MOUNTS.....	204	THREAD CHASERS.....	162	V-BELT PULLEY KITS.....	55,117
SPRING BUCKETS.....	20	THREADED BOSSES.....	201	VENT BREATHERS.....	116
SPRING RUBBERS.....	16,33	THREADED TUBES.....	50	VICTORY LANE TIRE SOFTENER.....	253
SPRING SEATS.....	16	THROTTLE BYPASSES & STOPS.....	104	VINYL SHELF MAT.....	177
SPRING SPACERS.....	16,17,20	THROTTLE LINKAGES.....	103	VICES.....	181
SPRING TESTERS.....	175	THROTTLE PEDALS.....	75,104	WARNING LIGHT KITS.....	187
SPRINT CAR CHASSIS & PARTS.....	14	THROWOUT BEARINGS.....	135,136	WASHABLE AIR FILTERS.....	115
SPRINT CAR HEADERS.....	244,245	TIE ROD ENDS, INNER & OUTER.....	48,49	WATER OUTLET NECKS & SPACERS.....	119
SPRINT CAR / MIDGET LEG PROTECTORS.....	193	TIE ROD END ADJUSTERS.....	49	WATER OUTLET RESTRICTOR KITS.....	119
SPRINT CAR / MIDGET REAR ENDS.....	151	TIE ROD END ADJUSTING SLEEVES.....	48	WATER PUMPS.....	119
SPROCKETS.....	177	TIE ROD END SHOCK ADAPTERS.....	28,30	WATER PUMP PULLEYS.....	55,117
SPUR GEARS, QUICK CHANGE.....	153	TIE ROD END SHOCK MOUNTS.....	28	WATER TEMPERATURE GAUGES.....	187
STABILIZER BARS & ACCESSORIES.....	49	TIE-DOWNS, RATCHET.....	181	WEIGHT JACK KITS.....	18,19
STAGGER GAUGES & STAGGER ROLLERS.....	171	TIMING BELT DRIVE KITS.....	96	WEIGHT JACK BOLTS, PLATES, NUTS.....	18,19,20
STARTERS & ACCESSORIES.....	130	TIMING CHAIN COVERS & BOLT KITS.....	96	WEIGHT JACK FRAME PLATES.....	20
STARTER BOLT KITS.....	250	TIMING CHAIN KITS.....	95	WELD TABS.....	200,201
STEEL BRAIDED HOSES WITH ENDS.....	67	TIMING GEAR DRIVES & MARK INDICATORS.....	96	WELD TABS, MOTOR PLATE.....	78
STEEL BRAIDED HOSES, -6 AN TO -16 AN.....	223	TIN SNIPS.....	180	WELD-IN THREADED BOSSES.....	201
STEEL BRAIDED HOSE ENDS.....	224	TIRES, 8" WIDE.....	170	WELDING CLAMP KITS.....	181
STEEL BRAIDED POWER STEERING HOSE.....	56	TIRE BEAD BREAKER.....	169	WELD-ON BRAKE BRACKETS.....	62
STEEL BRAKE LINES.....	67	TIRE DUROMETERS & TREAD DEPTH GAUGES.....	172	WELD-ON FRAME MOUNTS.....	216
STEEL COOLING FANS.....	120	TIRE GRINDING DISCS.....	171	WELD-ON GUSSETS & TUBE PLUGS.....	199
STEEL ROD ENDS.....	51	TIRE GROOVERS & TIRE SIPERS.....	170	WELD-ON STEERING COLUMN MOUNTS.....	58,201
STEEL WHEELS.....	164-169	TIRE LEAFS & ACCESSORIES.....	172	WHEELS.....	164-169
STEERING ARMS.....	44,45	TIRE MARKERS & TIRE TAPE MEASURES.....	171	WHEEL ADAPTERS.....	162
STEERING BOXES.....	58	TIRE PRESSURE GAUGES.....	171	WHEEL BEARING GREASE.....	160,255
STEERING BOX BOLT KITS, OEM & RACING.....	250	TIRE PYROMETERS.....	174	WHEEL SPACERS.....	163
STEERING COLUMN MOUNTS.....	58,201	TIRE SCRIBES.....	172	WHEEL STRAIGHTENING TOOLS.....	169
STEERING FLANGED BEARINGS.....	57	TIRE SOFTENER & CLEANER.....	253	WHEEL STUDS & LUG NUTS.....	162
STEERING QUICK DISCONNECTS.....	59	TIRE STAGGER GAUGES & STAGGER ROLLERS.....	171	WIDE 5 AXLES & AXLE TUBES.....	158,159
STEERING REDUCERS & MOUNTS.....	59	TOE-IN GAUGES & TOE-IN PLATES.....	172,173	WIDE 5 HUBS, BEARINGS, NUTS, ETC.....	160
STEERING ROD ENDS.....	51,57	TOP DEAD CENTER LOCATOR.....	103	WIDE 5 SPINDLES.....	61
STEERING SHAFTS.....	58	TORQUE ARMS & ACCESSORIES.....	203,204	WIDE 5 WHEEL ADAPTERS & SPACERS.....	162,163
STEERING SHAFT CLAMP COLLAR.....	57	TORQUE LINKS & ACCESSORIES.....	202,203	WIDE ANGLE MIRRORS.....	186
STEERING U-JOINTS & COUPLERS.....	58	TORQUE LINK COIL SPRINGS.....	16	WILWOOD BRAKE & CLUTCH PEDALS.....	72,73,74
STEERING WHEELS & STEERING WHEEL PADS.....	59	TORQUE LINK FRONT MOUNTS.....	216,217	WILWOOD BRAKE CALIPERS & PADS.....	68,69
STOCK A-ARM BUSHINGS.....	39,40,41	TORQUE LINK REAR MOUNTS.....	209	WILWOOD MASTER CYLINDERS.....	74,75
STOCK BALL JOINTS, UPPER & LOWER.....	40,41,42	TORQUE LINK RUBBER SPRINGS.....	203	WILWOOD WIDE 5 HUBS.....	160
STOCK CENTER LINKS.....	44,46,47	TOW ROPES.....	181	WINDOW CLEANER & WINDOW WIPES.....	178
STOCK CLIP HEADERS.....	234	TRACTOR PULL / TRUCK HEADERS.....	246	WINDOW MOUNTED DUCTS.....	77,196
STOCK FRONT HUBS & ROTORS.....	64	TRAILING ARMS.....	50	WINDOW NUTS & INSTALLATION KITS.....	198
STOCK FRONT HUB BEARING KITS.....	66	TRAILING ARM ADJUSTERS.....	207	WIRE SLEEVING.....	186
STOCK IDLER ARMS.....	44,46,47	TRAILING ARM FRONT MOUNTS.....	216,217	WIRE TIES.....	178
STOCK LOWER A-ARMS.....	39	TRAILING ARM REAR MOUNTS, WELD-ON.....	210	WIRING ACCESSORIES.....	189
STOCK MOUNT SHOCK ENDS.....	21	TRAILING ARM REAR MOUNTS, CLAMP-ON.....	210	WISHBONE TORQUE LINKS.....	202
STOCK PITMAN ARMS.....	45,46,47	TRAILING ARM REAR MOUNTS, FLOATING.....	212-215	WIX OIL FILTERS.....	85
STOCK-TYPE CLUTCHES & CLUTCH KITS.....	131,132	TRAILING ARM RUBBER MOUNTS.....	51	WORK LIGHTS, HALOGEN.....	181
STOP LEAK, COOLING SYSTEM.....	121,255	TRAILING ARM TABS.....	201,209	WRENCHES, ADJUSTABLE & AIR IMPACT.....	180
STOPS OVERHEATING COOLANT TREATMENT.....	254	TRANS AM CENTER LINKS.....	44-47	WRENCHES, FITTING, -AN TYPE.....	227
STOPWATCHES & CLIPBOARDS.....	175	TRANS AM IDLER ARMS & PITMAN ARMS.....	44-47	WRENCHES, SPANNER/COILOVER.....	28
STORAGE BUCKETS, 3RD MEMBER.....	157	TRANS AM TIE ROD ENDS.....	46-48	YOKES, 9" FORD.....	155
STRAIGHTENING TOOL, WHEEL.....	169	TRANSMISSIONS & PARTS.....	141-148	YOKES, DRIVESHAFT.....	150
STREET ROD FRONT HUBS & ROTORS.....	64	TRANSMISSION FLUID.....	255	YOKES, QUICK CHANGE.....	151
STREET ROD FUEL CELLS.....	221	TRANSMISSION MOUNTS, CHEVY.....	78	Z LINK FLOATERS, SWING ARM.....	207,212
STREET ROD HUB, ROTOR, & SPINDLE KITS.....	65	TRANSMISSION STANDS, SHIMS, & STUDS.....	148	ZOOMIE HEADERS.....	246





## **POLICIES - PLEASE READ BEFORE YOU PROCEED!**

**HOURS:** 9 a.m. to 6 p.m. Central Standard Time. Monday thru Friday.

**HOW TO ORDER:** We do not allow walk-in or will call orders. We accept telephone orders, website orders at [www.southwestspeed.com](http://www.southwestspeed.com), mail orders, and fax orders. Feel free to study this Parts Manual, as well as our website to determine what you need. Please order by PART NUMBER ONLY. Give your name, shipping address, and telephone number, followed by the quantity and part number of items desired. Our normal method of shipment is U.P.S. Ground Service. If you desire a different type of service, please advise us of that. All shipments are freight collect; we have no prepaid freight policy.

**ASSEMBLIES & OPTIONS:** Due to the vast number of assemblies & options we offer, it would be impossible to list all of the combinations in this parts manual. We do allow substitution of like items by simply ordering the assembly, deducting the standard part number, and adding the option part number. We do not allow deductions only from assemblies, unless it is noted in this parts manual.

**SPECIAL ORDERS:** Due to the fact that we are a true manufacturer and warehouse, we must produce or order most products in large quantities to assure competitive pricing and sufficient inventory. We will, however, place special orders for customers as a last resort. The customer will be responsible for any extra cost incurred, including special handling costs and freight bills.

**MULTIPLE INVOICES:** Due to the fact that we offer same day shipping, it would be impossible to accumulate invoices and process packages at the end of the day. We process orders the moment we receive them on a sequential basis. We strive to save you as much money on freight charges as possible. If you have more than one invoice in a day, we will try to accumulate these invoices and ship these orders in one shipment. If we are not able to catch the first order, they will be billed and treated as 2 separate orders. To avoid extra freight charges, try to place the complete order at one time.

**BACKORDERS:** All Backorders will be canceled, unless other arrangements are made.

**SPECIAL HANDLING CHARGES:**

A \$5.00 service charge will be added to any invoice under \$100.00 to offset invoicing and packing expenses.

A \$5.00 service charge will be added to all dropshipped orders.

**SALES TAX:** Merchandise shipped by Common Carrier out of Arkansas is exempt from sales tax. In state shipments will be charged sales tax unless an Arkansas Uniform Sales & Use Tax Certificate form is on file with Southwest Speed Incorporated.

**TERMS:** C.O.D. (Money Order & Cashier Check), VISA, MasterCard, & Discover Only - No Exceptions. We have no open accounts, no slow accounts, and no bad debts. This allows us to supply faster service and competitive pricing. Same day shipping of 100% of the order is our main goal. All orders received before 5:30 p.m. Central Standard Time are shipped the same day. Allowing charge accounts would drastically effect our efficiency levels, thus effecting our service and ultimately effecting our ability to attain our primary goal. This is the main reason we do not allow open accounts. If you absolutely will not accept C.O.D. Shipments & do not want to use a credit card, the alternative is to prepay your order with a Money Order or a Cashier's Check. Please do not send a personal check; it will slow your order delivery down because we will not ship until the check clears your bank.

**PRICING:** Due to the fact that prices are consistently changing these days, we haven't included a priceshet in this catalog. All prices are up-to-the-second on our website on each & every item, [www.southwestspeed.com](http://www.southwestspeed.com). Also, you can download a priceshet by going to [www.southwestspeed.com/prices](http://www.southwestspeed.com/prices). In addition, upon request, we will also be glad to mail you a hard priceshet or a priceshet on a CD. We can also simply email you a priceshet. Also, you can feel free to have the price quoted over the phone at the time of ordering.

***ALWAYS ORDER BY PART NUMBER***

---

**Place your order at (479) 646-6988, Fax to (479) 646-5939, or visit [www.southwestspeed.com](http://www.southwestspeed.com)**

---



## **POLICIES - PLEASE READ BEFORE YOU PROCEED!**

**NO WARRANTY! NO GUARANTEE!** SOUTHWEST SPEED offers racing components for sale only upon the conditions and upon the terms contained in this disclaimer of liability and indemnity. Due to many varied and different conditions which Racing Components are exposed and because of the manner in which racing is conducted, SOUTHWEST SPEED makes absolutely no warranty or guarantee, expressed or implied, as to the fitness for a general or particular purpose or of merchantability in connection with any offer of sale or sale of Racing Components. **"RACING COMPONENTS ARE SOLD AS IS!"** Use racing components and other parts at your own discretion.

**NO REPAIR! NO REBUILD!** We do not repair or rebuild any component or part of any kind. We have repair parts & rebuild kits available to allow the customer to do this service. Please do not send components or parts to us to repair or rebuild.

**BRAND DESIGNATION:** Any Brand Designation, Part Number, Symbol, Code, or any other similarities of any manufacturers products are for the sole purpose of identification and application only. Southwest Speed Inc., in no way denotes their use to infer or intend a direct or indirect connection between Southwest Speed Inc. or its products, and the factories of, or the names of, any other manufacturers listed in this Parts Manual.

**SUBSTITUTION:** Any Brand Designation, Part Number, Symbol, Code, or any other similarities of any manufacturers products are for the sole purpose of identification and application only. Therefore, Southwest Speed Inc. makes no guarantee as to Brand or Manufacturer of any product we sell, and reserves the right to substitute products, designs, material, and/or specifications of reasonable like products at any time. Southwest Speed Inc. has no allegiance or affiliation with any other firm or manufacturer.

**DIMENSIONS:** All Dimensions in this manual are of actual off the shelf parts at the time of this composition. Due to Manufacturer's tolerances, dimensions are nominal and for reference only.

**WEIGHTS:** All weights in this manual are of actual off the shelf parts at the time of this composition. Due to Manufacturer's tolerances, weights are nominal and should only be used for reference and shipping purposes only.

**PARTS MANUAL ERRORS:** We have made every effort possible to insure that this manual is accurate, however, should a typographical error appear in this manual, we will not be held responsible.

**DAMAGE CLAIMS:** Any claim for damage, pilferage, or loss in transit must be filed with U.P.S. or other common carrier. When shipment is taken by delivery agent, the merchandise is no longer ours and there is very little we can do to help. Be sure to save all packaging for showing agents of the common carrier. Any claim for parts shortages must be made within 10 days. Before claiming shortages, please note that shortages may be caused by unauthorized persons removing parts before contents are checked by receiving department or items being overlooked, miscounted, or discarded with packing materials.

**RETURN POLICY:** ABSOLUTELY NO RETURNS after 30 days for any reason. Make every effort to order by part number. We will not be responsible for parts shipped wrong that were ordered wrong! We will be responsible if the part is ordered by part number, but was shipped wrong. In the event you do receive the wrong part, do not try to use it or install it. Repackage it to avoid damage in transit and then return the item to Southwest Speed. Include a copy of the original invoice and instructions telling us what you wish to be done. We will not accept, for return, any parts that have been used, installed, unpackaged, shelf-worn, defective, rusty, or damaged in transit. We will not accept any returned part, which has had the Southwest Speed Inc. part number or logo decal removed. **NO EXCEPTIONS!** We do not sell used parts! Any part that is returned for restocking, refund, or exchange will be assessed a **20%** restocking fee, unless the part was mis-shipped by Southwest Speed Inc. Depending upon the condition of the packaging, a re-box or a re-bag fee could also be incurred. We do not issue cash refunds. Refunds will come via an in-store credit.

***ALWAYS ORDER BY PART NUMBER!***

---

**Place your order at (479) 646-6988, Fax to (479) 646-5939, or visit [www.southwestspeed.com](http://www.southwestspeed.com)**

---



# FEATURED NEW PRODUCTS

## KEIZER ALUMINUM WHEELS

- ★WE NOW CARRY THE FULL LINE OF KEIZER WHEELS FOR SPRINT CARS, MIDGETS, MICRO-SPRINTS, & GO-KARTS; WE ALSO CARRY ALL WHEEL CENTERS, MUD COVERS, ETC
- ★SEE [southwestspeed.com](http://southwestspeed.com) FOR THE FULL SELECTION



## TUBULAR CONTROL ARMS

- ★SOLD AS COMPLETE UPPER OR LOWER SETS
- ★UPPER SHAFTS & LOWER BUSHINGS MOUNT IN STOCK LOCATIONS & BALL JOINTS FIT STOCK SPINDLES;
- ★SEE [southwestspeed.com](http://southwestspeed.com) FOR MORE DETAIL

CONTROL ARM SETS	UPPER	LOWER
55-57 CHEVY TUBULAR	101-9160	101-9362
58-64 IMPALA TUBULAR	101-9163	101-9365
65-70 IMPALA TUBULAR	101-9166	101-9368
67-69 CAMARO TUBULAR	101-9169	101-9371
67-69 CAMARO STOCK	101-9390	101-9592
64-72 GM A-BODY TUBULAR	101-9172	101-9374
MUSTANG II TUBULAR	101-9194	101-9396



## VAN ALSTINE TIRE GROOVERS & SIPERS

- ★WE CARRY THE INDUSTRY-LEADING VAN ALSTINE G-1000 & V-100 TIRE GROOVERS & S-100 TIRE SIPER, AS WELL AS ALL BLADES FOR EACH
- ★THESE TOOLS ARE INSTANTLY HOT & FEATURE ADJUSTABLE HEAT SETTINGS



## HOWE LOW-FRICTION BALL JOINTS

- ★THESE PRECISION UPPER & LOWER BALL JOINTS OFFER VERY LOW RESISTANCE, WHILE STILL FULLY CAPTURING THE BALL TO MAINTAIN ALIGNMENT
- ★ALL BALL JOINTS COME WITH STEEL HOUSINGS WITH EITHER ALUMINUM OR STEEL CAPS ON THE END, WHICH IS USED TO CAPTURE THE BALL STUD IN THE HOUSING
- ★ALSO, THEY ALLOW YOU TO CHANGE THE BALL STUDS TO MODIFY THE ROLL CENTER



## BILSTEIN OE SHOCKS & STRUTS

- ★WE CARRY A COMPLETE SELECTION OF BILSTEIN STOCK REPLACEMENT SHOCKS & STRUTS
- ★WE HAVE THEM IN STOCK FOR 100'S OF APPLICATIONS, INCLUDING CORVETTE, CAMARO, CHEVELLE, IMPALA, CUTLASS, GTO, MUSTANG, THUNDERBIRD, BRONCO, HONDA CIVIC, VOLKSWAGEN, MAZDA MIATA, AUDI, 350Z, BMW E36, & MANY MORE, AS WELL AS CHEVY, GMC, FORD, TOYOTA, NISSAN, & SUZUKI TRUCKS & VANS



## SPRINT CAR, MIDGET, & MICRO PARTS

- ★WE NOW CARRY A FULL LINE OF OPEN WHEEL PARTS FROM BUMPER TO BUMPER



## TRIPLE X CHASSIS & PARTS

- ★SPRINT, MIDGET, & 600 MICRO-SPRINT CHASSIS & KITS AVAILABLE



## SALDANA RACING PRODUCTS

- ★WE NOW CARRY TAIL TANKS, RADIATORS, OIL TANKS, WHEEL WRENCHES, & MANY OTHER ITEMS FROM SALDANA RACING



## MICRO-SPRINT FRONT & REAR SPROCKETS

- ★AVAILABLE FOR HONDA, YAMAHA, & SUZUKI ENGINES FOR FACTOR 1, SAWYER, BAILEY, STALLARD, HYPER, TRIPLE X, PMP, & SIMILAR MICRO-SPRINT CHASSIS
- ★11-17 TOOTH FRONT & 44-55 TOOTH REAR SPROCKETS AVAILABLE



Place your order at (479) 646-6988, Fax to (479) 646-5939, or visit [www.southwestspeed.com](http://www.southwestspeed.com)

# FEATURED NEW PRODUCTS

## WILWOOD PREMIUM BOLT-ON DISC BRAKE KITS

- ★WE HAVE THE LARGEST IN-STOCK SELECTION OF WILWOOD DISC BRAKES ANYWHERE
- ★THESE BOLT-ON KITS CONSIST OF SPECIFICALLY ENGINEERED & MATCHED GROUPS OF COMPONENTS



SEE southwestspeed.com

DESIGNED TO PROVIDE SUPERIOR BRAKE SYSTEM PERFORMANCE & CUSTOM APPEAL OVER A WIDE RANGE OF APPLICATIONS

- ★FROM 10.75" DIAMETER DRAG KITS TO 16" KITS FOR HUMMERS & HD TRUCKS, WE HAVE THEM ALL ON THE SHELF & READY TO SHIP
- ★KITS IN STOCK FOR CHEVY, FORD, OLDS, BUICK GMC, CADILLAC, PONTIAC, HUMMER, HONDA, ACURA, AMC, AUDI, BMW, CHRYSLER, DODGE, INFINITI, JEEP, MAZDA, MERCURY, MINI-COOPER, MITSUBISHI, NISSAN, PACKARD, PLYMOUTH, PT CRUISER, SAAB, SCION, SUBARU, VW, & MORE

## WILWOOD DUAL MASTER CYLINDERS

- ★THESE DUAL OUTLET, ALUMINUM TANDEM CHAMBER CYLINDERS REPRESENT THE LATEST REFINEMENTS IN BRAKE PRESSURE ACTUATION & FLUID CONTROL
- ★FITS MOST STOCK BOLT PATTERNS & INCLUDES SEVERAL FITTINGS TO ADAPT TO MOST STOCK LINES



#WIL 260-8555

PAGE 74

BORE SIZE	SATIN	POLISHED	BLACK
7/8" BORE	260-9439	260-9439-P	260-9439-BK
1" BORE	260-8555	260-8555-P	260-8555-BK
1 1/8" BORE	260-8556	260-8556-P	260-8556-BK

## WILWOOD ADJUSTABLE COMBINATION PROPORTIONING VALVE

- ★SIMPLIFIES MOUNTING, FLUID CIRCUIT PLUMBING, BRAKE LIGHT WIRING, & BRAKE BIAS ADJUSTMENT
- ★MAINTAINS FULL SEPARATION BETWEEN FRONT & REAR FLUID CIRCUITS
- ★THE VALVE ITSELF WILL MOUNT IN SOME STOCK LOCATIONS
- ★IT IS ALSO AVAILABLE WITH THE MOUNTING BRACKET & LINES TO CONNECT IT TO THE WILWOOD TANDEM CHAMBER CYLINDERS



VALVE WITH BRACKETS & LINES: #WIL 260-13190  
VALVE ONLY: #WIL 260-11179

## NEW BRAKE BOOSTERS

- ★HIGH QUALITY BRAKE BOOSTERS AVAILABLE FOR MANY DIFFERENT APPLICATIONS
- ★ZINC & CHROME TO CHOOSE FROM
- ★7", 8", 9", & 11" DIAMETER BOOSTERS AVAILABLE WITH SINGLE OR DUAL DIAPHRAGMS
- ★THE BRACKETS LISTED BELOW CAN BE INSTALLED ON ANY OF THE BOOSTERS AT THE TOP



#300-7963

#300-7975

BOOSTERS	ZINC	CHROME
7" BOOSTER, SINGLE	300-7950	300-7951
7" BOOSTER, DUAL	300-7954	300-7955
8" BOOSTER, SINGLE	300-7958	300-7959
8" BOOSTER, DUAL	300-7962	300-7963
9" SINGLE WITH 64-66 GM A- BRACKETS	300-7966	300-7967
11" SINGLE W/ 67-72 GM A- & F-BRACKETS	300-7974	300-7975
BRACKETS ONLY	ZINC	CHROME
55-64 CHEVY, IMPALA, BEL AIR, ETC	300-7909	300-7910
64-72 GM A-BODY & 67-69 GM F-BODY	300-7901	300-7902
70-81 GM F-BODY (CAMARO/FIREBIRD)	300-7905	300-7906
57-72 FORD TRUCK	300-7862	-
65-70 CDP A-BODY & 65-74 CDP E-BODY	300-7866	-
JEEP CJ	300-7870	-

## NEW MASTER CYLINDERS

- ★THESE ARE DESIGNED AS STOCK REPLACEMENT CYLINDERS, WITH A SLOTTED 2 BOLT MOUNTING FLANGE THAT ACCEPTS 3/8" & 10mm BOLTS & ALLOWS FOR MOUNTING TO 3 1/8", 3 1/4", & 3 3/8" CENTER-TO-CENTER BOLT PATTERNS
- ★AVAILABLE IN STOCK LOOK VERSION, AS WELL AS IN ALUMINUM & POLISHED ALUMINUM, WITH DIFFERENT BORE SIZES & SEVERAL DIFFERENT PORT CONFIGURATIONS



#300-8010

#300-8030

MASTER CYLINDERS	PORTS	PORT SIDE	STOCK LOOK	ALUMINUM	POLISHED ALUMINUM
1" BORE	3/8"	BOTH	300-8010	300-8030	300-8032
1" BORE	1/2" & 9/16"	LEFT	300-8012		
1" BORE	1/2" & 9/16"	BOTH	300-8014		300-8040
1" BORE W/SLEEK FLAT LID	1/2" & 9/16"	BOTH			300-8042
1 1/8" BORE	1/2" & 9/16"	LEFT	300-8016		300-8044
1 1/8" BORE	1/2" & 9/16"	BOTH	300-8018		
1 1/8" W/SLEEK FLAT LID	1/2" & 9/16"	BOTH		300-8034	300-8046
1 1/8" W/BLEEDERS	1/2" & 9/16"	LEFT	300-8020		
1 1/8" FOR 73-78 CDP B-BODY	1/2" & 9/16"	LEFT	300-8024		
1 1/4" W/ 1/2" ADAPTER	3/8" & 9/16"	LEFT	300-8022		
PROPORTIONING VALVES			BRASS	ALUMINUM	CHROME
DISC/DRUM			300-8070		300-8071
DISC/DISC			300-8074	300-8075	

## BOLT SPACERS & REDUCERS

- ★100's OF STEEL & ALUMINUM, FLAT & TAPERED SPACERS, AS WELL AS 2 TYPES OF ROD END REDUCERS



PAGE 205

Place your order at (479) 646-6988, Fax to (479) 646-5939, or visit [www.southwestspeed.com](http://www.southwestspeed.com)



# FEATURED NEW PRODUCTS

## WILWOOD GP310 HARLEY BRAKE CALIPERS

PAGE 176



WIL 120-7737



WIL 120-7740-BK

- ★ GP310 CALIPERS ARE 4-PISTON, HIGH-PERF POWERHOUSES; THE BILLET ALUMINUM CALIPER BRINGS DISTINCTIVE, BOLT-ON STYLING TO HARLEY'S & SIMILAR BIKES
- ★ FRONT & REAR AVAILABLE IN CHROME & POLISHED, AS WELL AS BLACK & RED COATING
- ★ "BOLT PATTERN" REFERS TO THE CENTER-TO-CENTER DISTANCE ON THE 2 MOUNTING HOLES

FINISH	BOLT PATTERN	LEFT	RIGHT
<b>1984-1999 FRONT CALIPER FOR 11.50" DIAMETER ROTORS</b>			
CHROME	3.44"	WIL 120-7737	WIL 120-7736
POLISHED	3.44"	WIL 120-7737-P	WIL 120-7736-P
BLACK	3.44"	WIL 120-7737-BK	WIL 120-7736-BK
RED	3.44"	WIL 120-7737-RD	WIL 120-7736-RD
<b>2000-2007 FRONT CALIPER FOR 11.50" DIAMETER ROTORS</b>			
CHROME	2.72"	WIL 120-7739	WIL 120-7738
POLISHED	2.72"	WIL 120-7739-P	WIL 120-7738-P
BLACK	2.72"	WIL 120-7739-BK	WIL 120-7738-BK
RED	2.72"	WIL 120-7739-RD	WIL 120-7738-RD
<b>2008-2013 FRONT CALIPER FOR 11.80" DIAMETER ROTORS</b>			
CHROME	2.72"	WIL 120-12117	WIL 120-12116
POLISHED	2.72"	WIL 120-12117-P	WIL 120-12116-P
BLACK	2.72"	WIL 120-12117-BK	WIL 120-12116-BK
<b>1984-2013 REAR CALIPER FOR 11.50" DIAMETER ROTORS</b>			
CHROME	3.50"	WIL 120-7741	WIL 120-7740
POLISHED	3.50"	WIL 120-7741-P	WIL 120-7740-P
BLACK	3.50"	WIL 120-7741-BK	WIL 120-7740-BK
RED	3.50"	WIL 120-7741-RD	WIL 120-7740-RD

## WILWOOD HANDLEBAR MASTER CYLINDERS

PAGE 176

- ★ WILWOOD'S 5/8" BORE HANDLEBAR MASTER CYLINDERS ARE COMPACT, LIGHTWEIGHT, & SPECIFICALLY DESIGNED FOR A VARIETY OF RECREATIONAL & SPORT/OUTDOOR APPLICATIONS
- ★ CONSTRUCTED OF MATERIALS & FINISHES DESIGNED TO RESIST CORROSION, THESE CYLINDERS FIT STANDARD 7/8" DIAMETER HANDLEBARS
- ★ IMPACT RESISTANT LEVER COMES WITH A 3-POSITION HYDRAULIC PARKING BRAKE LOCK



WIL 260-4201

DESCRIPTION	PART #
LEFT-HAND CYLINDER	WIL 260-4201
RIGHT-HAND CYLINDER	WIL 260-4202
LEFT CYLINDER, LONG LEVER	WIL 260-11219
RIGHT CYLINDER, LONG LEVER	WIL 260-11218

## MCP MICRO-SPRINT/KARTING, MASTER CYLINDERS

PAGE 177

- ★ MCP CYLINDERS ARE GREAT FOR MICRO/MINI-SPRINTS, RACING & RECREATIONAL GO-KARTS, MINI-CUP CARS, QUARTER MIDGETS, JR. DRAGSTERS, RACING LAWN MOWERS OR BARSTOOLS
- ★ THE HIGH-PERFORMANCE, CAST ALUMINUM CYLINDER BODY FEATURES ETHYL PROPYLENE SEALS, WHICH ALLOW THEM TO BE USED WITH DOT 3, DOT 4, OR DOT 5 BRAKE FLUID



## MCP MICRO-SPRINT/KARTING, BRAKE CALIPERS

- ★ GREAT FOR ALL THE ABOVE LIGHT-DUTY APPLICATIONS



SEE southwest speed.com

## MCP MICRO-SPRINT/KARTING, BRAKE ROTORS & HUBS

- ★ ROTORS ARE AVAILABLE IN SEVERAL 3, 4, 5, & 6 BOLT PATTERNS, FROM 6" TO 10" DIAMETER & 1/8", 3/16", & 1/4" THICK
- ★ HUBS ARE AVAILABLE FOR 1", 1 1/4", & 1 3/8" AXLES



SEE southwest speed.com

## MOTORCYCLE & KARTING FRONT SPROCKETS

- ★ WE HAVE FRONT SPROCKETS TO FIT HONDA, YAMAHA, KAWASAKI, SUZUKI, TRIUMPH, KTM, & HARLEY BIKES
- ★ THESE WILL ALSO FIT GO-KARTS & MICRO-SPRINTS THAT USE THESE BRANDS OF ENGINES
- ★ FOR THE HARLEY'S, WE HAVE OE REPLACEMENT SPROCKETS, AS WELL AS OFFSET VERSIONS



SEE southwest speed.com

## WILWOOD MOTORCYCLE BRAKE ROTORS

WIL 160-10662



PAGE 176

- ★ WILWOOD STAINLESS ROTORS COMBINE THE ULTIMATE IN PERFORMANCE & DISTINCTIVE STYLE FOR PRODUCTION BIKES & FULL CUSTOMS USING OE DIMENSION BRAKE COMPONENTS
- ★ .200" THICK x 11.50" DIAMETER
- ★ CAN BE USED AS A DIRECT REPLACEMENT, FOR 11.50" DIAMETER ROTORS, W/OE CALIPERS OR COUPLED WITH WILWOOD GP CALIPERS
- ★ ROTORS HAVE A 5 x 3.25" BOLT CIRCLE WITH .344" HOLES ON THE FRONT & .422" ON THE REAR
- ★ THE CENTER REGISTRATION HOLE MEASURES 1.99" ON THE 1984-1999 & 2.22" ON THE 2000-2008



WIL 160-10665-BK

	SATIN	POLISHED	BLACK
<b>1984-1999 MOTORCYCLE FRONT ROTORS</b>			
WIL 160-10662	WIL 160-9913-P	WIL 160-10662-BK	
<b>1984-1999 MOTORCYCLE REAR ROTORS</b>			
WIL 160-10663	WIL 160-9914-P	WIL 160-10663-BK	
<b>2000-2008 MOTORCYCLE FRONT ROTORS</b>			
WIL 160-10664	WIL 160-9915-P	WIL 160-10664-BK	
<b>2000-2008 MOTORCYCLE REAR ROTORS</b>			
WIL 160-10665	WIL 160-9916-P	WIL 160-10665-BK	

## WILWOOD FOOT PEDAL MASTER CYLINDERS

PAGE 176



WIL 260-10377

- ★ THESE MOTORCYCLE FOOT MASTER CYLINDERS FEATURE A HIGH QUALITY "SHOW CHROME" FINISH
- ★ BILLET ALUMINUM, THIS FORWARD CONTROL CYLINDER COMES WITH AN INDUSTRY STANDARD 5/8" BORE
- ★ SIDE MOUNTING HOLES ARE 2.25" CENTER-TO-CENTER

LEFT FOOT #WIL 260-10378  
RIGHT FOOT #WIL 260-10377

Place your order at (479) 646-6988, Fax to (479) 646-5939, or visit [www.southwestspeed.com](http://www.southwestspeed.com)

# FEATURED NEW PRODUCTS

## KIRKEY SEATS - NEW SERIES

DRAG RACING SEATS

PAGE 190



ROAD RACING SEATS

PAGE 190



DRAG/ROAD RACE FULL CONTAINMENT SEATS

SEE southwest speed.com



VINTAGE BUCKET SEATS

SEE southwest speed.com



21" BIG BOY SEATS

SEE southwest speed.com



ECONOMY FULL CONTAINMENT SEATS

PAGE 191



MICRO/MINI-SPRINT ECONOMY & FULL CONTAINMENT SEATS

SEE southwest speed.com



69 SERIES SPRINT CAR FULL CONTAINMENT SEATS

SEE southwest speed.com



QUARTER MIDGET SEATS

SEE southwest speed.com



## ALUMINUM, NEEDLE BEARING THROTTLE PEDALS

★3 CONFIGURATIONS AVAILABLE

★SPLINED PIVOT SHAFT SUPPORTED BY DUAL NEEDLE BEARINGS & A KNURLED ALUMINUM ROLLER FOOT PEDAL ENSURE THIS WILL BE THE SMOOTHEST OPERATING PEDAL ON THE MARKET



PAGE 75

## GRANADA 2ND DESIGN RACING HUB & ROTOR

PAGE 64

★EXCLUSIVE 2ND DESIGN ROTOR HAS AN OUTBOARD DESIGN & WILL CLEAR THE LOWER A-ARMS WITH NO MODIFICATIONS TO EITHER PART  
★L.W. DESIGN WEIGHS ONLY 15.70 LBS.



## PINTO/MUSTANG II SPINDLES THAT ARE ALREADY TAPPED & REAMED FOR RACING APPLICATIONS

PAGE 60

★ALONG WITH THE STOCK SPINDLES, WE NOW HAVE A VERSION THAT HAS THE STEERING ARM TAPPED 5/8"-18 & A VERSION THAT HAS THE LOWER BALL JOINT HOLE REAMED & THE STEERING ARM TAPPED 5/8"-18



## RCI DRAG RACE FUEL CELLS

★HI-STRENGTH POLYETHYLENE BLADDERS

★INCLUDES:

#8 AN MALE FITTINGS, 2 PICKUPS ON 2" SUMP, & ROLLOVER VENT

★U-BRACKET MOUNTING

KITS ARE AVAILABLE AS WELL

PAGE 221



#RCI 1040D

#RCI 1120D

RCI DRAG FUEL CELLS	NO FOAM	WITH FOAM	MOUNT KIT
1 GALLON, 6Lx6Wx12H	RCI 1010D	RCI 2010D	-
4 GALLON, 9Lx9Wx12H	RCI 1040D	RCI 2040D	RCI 7404A
5 GALLON, 13Lx13Wx8H	RCI 1050D	RCI 2050D	RCI 7405A
8 GALLON, 17Lx17Wx8H	RCI 1080D	RCI 2080D	RCI 7408A
12 GALLON, 17Lx17Wx11H	RCI 1120D	RCI 2120D	RCI 7412A
12 GAL, 17x17x11, SENDING	RCI 1120DS	-	RCI 7412A
16 GALLON, 23Lx17Wx11H	RCI 1160D	RCI 2160D	RCI 7416A
16 GAL, 23x17x11, SENDING	RCI 1160DS	-	RCI 7416A

## RCI ALUMINUM STREET ROD FUEL CELLS

PAGE 221

★TIG-WELDED 5051 AIRCRAFT ALUMINUM

★#8 AN FITTINGS & ROLLOVER VENT

★AVAILABLE WITH FOAM & WITH SENDING UNITS



#RCI 2100A

#RCI 2171A

RCI ALUMINUM FUEL CELLS WITH FOAM	MOUNT KIT
1 GALLON, 7Lx6Wx8H	RCI 2010A
3 GALLON, 8Lx8Wx15H	RCI 2030A
4 GALLON, 8Lx12Wx8H	RCI 2040A
5 GALLON, 12Lx12Wx8H	RCI 2050A
10 GALLON, 17Lx17Wx9H	RCI 2100A
10 GAL, 17x17x9, SENDING	RCI 2100AS
15 GALLON, 18Lx20Wx10H	RCI 2150A
15 GAL, 18x20x10, W/SENDING	RCI 2150AS
20 GALLON, 24Lx20Wx10H	RCI 2200A
20 GAL, 24x20x10, W/SENDING	RCI 2200AS
RCI ALUM CELLS WITH SENDING UNIT, NO FOAM	MOUNT KIT
12 GALLON, 18Lx12Wx12H	RCI 2121A
15 GALLON, 30Lx9Wx12H	RCI 2161A
15 GALLON, 30Lx12Wx9H	RCI 2162A
17 GALLON, 30Lx7Wx17H	RCI 2171A
17 GALLON, 30Lx17Wx7H	RCI 2172A
19 GALLON, 30Lx12Wx12H	RCI 2191A

## FUEL SAFE PRODUCTS

★WE NOW CARRY FUEL SAFE CELLS INCLUDING SPRINT CAR TANKS AND FORD MUSTANG PRO & SPORT TANKS

★SEE southwestspeed.com FOR THE FULL LINE



Place your order at (479) 646-6988, Fax to (479) 646-5939, or visit [www.southwestspeed.com](http://www.southwestspeed.com)



# FEATURED NEW PRODUCTS

## BILLET SPECIALTIES SERPENTINE TRU-TRAC FRONT ENGINE KITS

PAGE 184

- ★BILLET SPECIALTIES TRU-TRAC SERPENTINE SYSTEMS ARE THE MOST COMPLETE SYSTEMS ON THE MARKET
- ★ENGINEERED TO BOLT RIGHT ON & ALIGN PERFECTLY W/O THE NEED FOR STABILIZER BRACKETS OR ADJUSTER BARS
- ★CNC MACHINED & POLISHED TO A MIRROR FINISH, THE TRU-TRAC NOT ONLY LOOKS AWESOME, BUT IT PERFORMS
- ★QUALITY IS ABUNDANT IN EVERY ASPECT OF EACH TRU-TRAC
- ★EVERY BRACKET & PULLEY IS MACHINED FROM 6061-T6 BILLET ALUMINUM FOR EXCEPTIONAL STRENGTH & RIGIDITY
- ★AVAILABLE FOR SBC, BBC, CHEVY 348/409, CHEVY LS, SB FORD, BBF, CHRYSLER, & PONTIAC



## POWER STEERING RESERVOIRS FOR TRU-TRAC KITS

- ★DESIGNED TO BE USED WITH TRU-TRAC SYSTEMS, BUT WILL WORK WITH OTHER POWER STEERING SYSTEMS
- ★INTERNALLY BAFFLED TO PREVENT SPLASH OVER
- ★BILLET ALUMINUM, POLISHED TO A MIRROR FINISH, ALSO AVAILABLE IN BLACK ANODIZED
- ★REMOTE & BOLT-ON TANKS AVAILABLE



PAGE 185



## POWER STEERING HOSE KIT FOR TRU-TRAC KITS

- ★THIS KIT IS DESIGNED TO BE USED WITH TRU-TRAC SYSTEMS, BUT WILL WORK WITH OTHER POWER STEERING SYSTEMS AS WELL
- ★EACH KIT IS SUPPLIED WITH ENOUGH ADAPTERS TO COVER MOST POPULAR GM BOXES & FORD-TYPE RACK



PAGE 185

## BILLET SPECIALTIES POLISHED V-BELT PULLEYS

- ★BILLET PULLEYS ARE CNC MACHINED FROM FORGED 6061-T6 ALUMINUM FOR THE ULTIMATE IN STRENGTH & BALANCE
- ★DESIGNED FOR USE WITH V-GROOVE STYLE BELTS ON CHEVY ENGINES, EACH PULLEY IS POLISHED TO A MIRROR FINISH

PAGE 185



## BILLET SPECIALTIES CHEVY SERPENTINE CONVERSION KIT

PAGE 185

- ★THESE KITS INCLUDE THE BRACKETS & PULLEYS TO CONVERT SBC & BBC ENGINES TO SERPENTINE
- ★KITS DON'T INCLUDE THE ACTUAL ALTERNATOR, WATER PUMP OR POWER STEERING PUMPS, A/C COMPRESSOR, ETC; ONLY THE POLISHED BRACKETS, PULLEYS, & BOLTS
- ★FITS LONG WATER PUMPS, GM 10SI OR 12SI ALTERNATORS, SAGINAW TYPE 1 POWER STEERING PUMPS (BOTH PRESS-ON & KEYWAY AVAILABLE), & SANDEN 508 A/C COMPRESSORS
- ★KITS EITHER MOUNT THE ALTERNATOR TO THE TOP OR MIDDLE OF THE PASSENGER'S SIDE
- ★BRACKETS & PULLEYS ARE MACHINED FROM 6061-T6 BILLET ALUMINUM & POLISHED TO A MIRROR FINISH



## POWERMASTER ALTERNATORS

- ★POWERMASTER STOCK REPLACEMENT ALTERNATORS IN NATURAL, BLACK, CHROME & POLISHED AS A POWER UPGRADE FOR THOUSANDS OF DIFFERENT GM, FORD, & JEEP APPLICATIONS
- ★SEE [southwestspeed.com](http://southwestspeed.com) FOR THE ALTERNATORS AVAILABLE

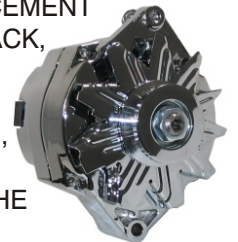

## NEW SBC LIGHTWEIGHT BELLHOUSING

- ★LIGHTWEIGHT STEEL CONSTRUCTION **PART #650-400**
- ★WEIGHS ONLY 17.5 LBS.
- ★WORKS WITH ALL GM TRANSMISSIONS WITH A 4.675" O.D. BEARING RETAINER



PAGE 137

## SWIVELING SHOCK MOUNT

- ★EXCLUSIVELY DESIGNED SHOCK MOUNT BOLTS TO ANY EXISTING FLOATER SHOCK MOUNT, ENABLING THE SHOCK TO SWIVEL

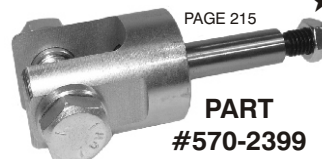

PAGE 215

**PART #570-2399**

## 8" WIDE SOUTHWEST SPEED TIRE

- ★26.0" X 8.0" X 15"
- ★WITH THE COST OF RACING CONTINUALLY INCREASING, SOUTHWEST SPEED HAS FOUND A WAY TO STABILIZE THE COST OF THE TIRE
- ★THIS TIRE COSTS \$69.99 & WILL LAST UP 4 TO 5 TIMES LONGER THAN OTHER BRANDS

PAGE 170



Place your order at (479) 646-6988, Fax to (479) 646-5939, or visit [www.southwestspeed.com](http://www.southwestspeed.com)

# FEATURED NEW PRODUCTS

## KINSLER FUEL INJECTION PRODUCTS

★WE CARRY A COMPLETE LINE OF KINSLER PRODUCTS, INCLUDING TOUGH FUEL PUMPS, MANIFOLDS, JACK SHAFT KITS, NOZZLES, SPRINGS, JETS, JET CANS, BYPASS VALVES, COCKPIT JET SELECTORS, FUEL SHUT OFFS, FUEL ANALYZER KITS, & MUCH MORE

★SEE [southwestspeed.com](http://southwestspeed.com) FOR ALL ITEMS



## WATERMAN RACING PRODUCTS

★WE CARRY A COMPLETE LINE OF WATERMAN PRODUCTS, INCLUDING THE WRC SPRINT FUEL PUMPS, SPRINGS, JETS, JET CANS, BYPASS VALVES, & MUCH MORE

★SEE [southwestspeed.com](http://southwestspeed.com) FOR THE COMPLETE SELECTION



## KSE TANDEM X POWER STEERING & FUEL PUMPS

PAGE 56

- ★TANDEM X PUMPS HAVE LATEST IN POWER STEERING PUMP & FUEL PUMP TECHNOLOGY
- ★UTILIZES A SINGLE SHAFT DRIVE TO OPERATE BOTH PUMPS FOR REDUCED MECHANICAL EFFICIENCY LOSSES
- ★THE TANDEM X IS COMPACT & DESIGNED TO FIT ALMOST ANY RACING APPLICATION
- ★INCLUDES AN INTEGRAL POWER STEERING RELIEF & A SLEEK, NEW LIGHTENED PROFILE WHICH HAS ALLOWED FOR A 25% WEIGHT REDUCTION OVER THE PREVIOUS DESIGN
- ★BELT OR DIRECT DRIVE AVAILABLE
- ★DIFFERENT VOLUME PUMPS AVAILABLE, AS WELL AS A "CLOCKWISE" VERSION DESIGNED TO BE MOUNTED ON THE FRONT OF THE ENGINE



## KSE GEN2 SPRINT CAR & MIDGET POWER STEERING GEARS

- ★KSE GEN2 STEERING GEARS ARE THE INDUSTRY LEADER W/INTEGRAL RESERVOIR & IN-BOARD MOUNT DESIGN
- ★THE RESERVOIR IS BUILT INTO THE LIVE HUB TUBE OF THE GEAR, WHICH HELP ELIMINATE TURBULENCE & AERATION, AND PROVIDES THE MOST COOLING OF ANY TANK KSE HAS TEST
- ★THE GEN2 HAS POSITIVE & CONSISTENT FEEL, IMPROVED DURABILITY, SIMPLIFIED PLUMBING, CLEAN & EASY INSTALLATION, NO TIGHT SPOTS, AND, AT 25% LIGHTER THAN THE PREVIOUS GEN1, IT IS THE LIGHTEST STEERING GEAR AVAILABLE
- ★INCLUDES PULL-TYPE STEERING WHEEL QUICK RELEASE HUB
- ★AVAILABLE FOR SPRINT CARS (11" INPUT SHAFT) & MIDGETS (10" INPUT SHAFT) WITH A COUPLE OF DIFFERENT OPTIONS, INCLUDING BLACK COATING



SEE [southwestspeed.com](http://southwestspeed.com)

## KSE SPRINT & MIDGET FRONT COVER ASSEMBLIES WITH WATER PUMP

SEE [southwestspeed.com](http://southwestspeed.com)

- ★KSE FRONT COVER ASSEMBLIES ARE PREFERRED BY THE NATION'S PREMIER ENGINE BUILDERS
- ★STANDARD CAM POSITION
- ★COMPATIBLE WITH ALL GEAR & CHAIN CAM DRIVE SYSTEMS
- ★BOLT PATTERNS ACCEPT ALL POPULAR DRY SUMP PUMPS & FUEL PUMPS
- ★AVAILABLE IN ALUMINUM OR BILLET ALUMINUM, WITH KSE'S STANDARD OR HPD WATER PUMP, WITH STEEL OR ALUMINUM CRANK DRIVES, AND WITH HOSE MOUNT BLOCKS, 2 SHORT BLOCK-OFFS, OR 1 SHORT & 1 LONG BLOCK-OFF
- ★FEATURES A LEXAN TIMING WINDOW



## KSE STINGRAY WING SLIDER CYLINDER & SLIDER VALVE

SEE [southwestspeed.com](http://southwestspeed.com)

- ★KSE HIGH PRESSURE WING SLIDER CYLINDER IS ENGINEERED WITH INTERNAL QUAD-SEAL TECHNOLOGY
- ★10" LONG, 1300 PSI, -3 AN PORTS
- ★ROD END BEARING MOUNTING
- ★LIGHTWEIGHT, 3-PIECE, ALL-BILLET SLIDER VALVE UTILIZES HIGH-FLOW PORTING & PRECISION SEAL TECHNOLOGY FOR SUPERIOR WING PERFORMANCE
- ★SLEEK DESIGN MAKES IT 30% LIGHTER THAN OTHER WING VALVES



Place your order at (479) 646-6988, Fax to (479) 646-5939, or visit [www.southwestspeed.com](http://www.southwestspeed.com)



# Southwest Speed Open Wheel

## TRIPLE X CHASSIS

- ★ CHASSIS & KITS AVAILABLE
- ★ CHASSIS ARE MADE FROM HIGH-GRADE 4130 CHROMOLY TUBING THAT IS PRE-TESTED FOR CHEMICAL COMPOSITION, HARDNESS, & STRENGTH
- ★ THE TRIPLE X CHASSIS HAS THE SAME DESIGN AS ALMOST ALL OTHER CHASSIS ON THE MARKET, INCLUDING THE EXACT PICKUP POINTS, MOTOR PLATE & TORSION TUBE LOCATIONS, ETC
- ★ CHASSIS KIT B INCLUDES BODY & TIN WORK
- ★ SPRINT CAR CHASSIS KIT A INCLUDES BODY, TIN WORK, BUMPERS & NERF BARS, MOTOR PLATE, FRONT END, MUCH OF THE STEERING, AND MUCH OF THE FRONT & REAR SUSPENSION
- ★ MIDGET "RACER" KIT INCLUDES BODY, TIN, BUMPERS, NERF BARS, TORSION ARMS & STOPS, PEDALS, FRONT AXLE, SUSPENSION RODS, DRAG LINK, TIE ROD, & PITMAN ARM
- ★ 600 MICRO "RACER" KIT INCLUDES BODY, TIN WORK, BUMPERS, NERF BARS, TORSION ARMS & STOPS, AND FRONT AXLE
- ★ 600 "SUPER DELUXE" KIT INCLUDES ALL THE ITEMS IN THE "RACER" KIT, PLUS THE MAJORITY OF THE ITEMS FOR THE SUSPENSION, STEERING, FRONT END, REAR END, DRIVELINE, BRAKES, ENGINE, & WING MOUNTING THAT'S NEEDED TO GO RACING

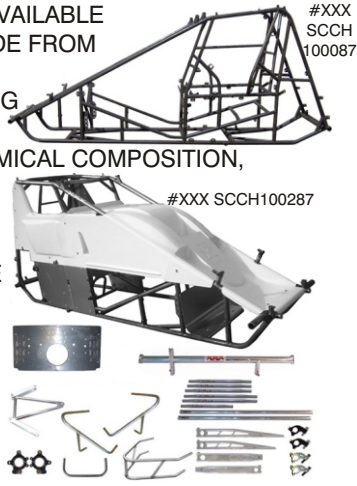

# SPRINT, MIDGET, & MICRO PARTS

- ★ WE STOCK & MANUFACTURE A COMPLETE LINE OF OPEN WHEEL ITEMS, INCLUDING AXLES, ALL SUSPENSION & STEERING PARTS, HUBS & BRAKES, COMPLETE REAR ENDS & ALL REAR COMPONENTS, ALL DRIVETRAIN PARTS, WINGS & MOUNTS, KEIZER WHEELS, & MUCH MORE
- ★ MANY OPEN WHEEL PRODUCTS ARE LISTED TO THE RIGHT
- ★ SEE [southwestspeed.com](http://southwestspeed.com) FOR MANY MORE PRODUCTS, AS WELL AS PICTURES & DETAILS ON EACH ITEM
- ★ FOR THE AXLES LISTED, LENGTH IS MEASURED CENTER-OF-KING-PIN-BOSS TO CENTER-OF-KING-PIN-BOSS



SPRINT CAR	PART #
BARE CHASSIS, 87/40	XXX SCCH100087
BARE CHASSIS, 87/40, 2" TALLER	XXX SCCH1000872
BARE CHASSIS, 88/40	XXX SCCH100088
BARE CHASSIS, 88/40, 2" TALLER	XXX SCCH1000882
CHASSIS KIT B, 87/40	XXX SCCH100187
CHASSIS KIT B, 87/40, 2" TALLER	XXX SCCH1001872
CHASSIS KIT B, 88/40	XXX SCCH100188
CHASSIS KIT B, 88/40, 2" TALLER	XXX SCCH1001882
CHASSIS KIT A, 87/40	XXX SCCH100287
CHASSIS KIT A, 87/40, 2" TALLER	XXX SCCH1002872
CHASSIS KIT A, 88/40	XXX SCCH100288
CHASSIS KIT A, 88/40, 2" TALLER	XXX SCCH1002882
MIDGET	PART #
BARE CHASSIS	XXX MDCH1000
CHASSIS KIT B	XXX MDCH1001
"RACER" CHASSIS KIT	XXX MDCH1002
600 MICRO-SPRINT	PART #
BARE CHASSIS	XXX 600CH1000
CHASSIS KIT B	XXX 600CH1001
"RACER" CHASSIS KIT	XXX 600CH1002
"SUPER DELUXE" CHASSIS KIT	XXX 600CH1008

SPRINT CAR	SILVER	BLACK		
FRONT TORSION ARM, LEFT, 18 3/4"	003-1611	003-1612		
FRONT TORSION ARM, LEFT, S-BEND	003-1607	003-1608		
FRONT TORSION ARM, RIGHT, 16 3/4"	003-1622	003-1623		
FRONT TORSION ARM, RIGHT, 10 DEGREE	003-1626	003-1627		
REAR TORSION ARM, LEFT, 15", 2 1/2" BEND	003-6709	003-6710		
REAR TORSION ARM, LEFT, 15", 3" BEND	003-6713	003-6714		
REAR TORSION ARM, LEFT, 15", 3 1/2" BEND	003-6715	003-6716		
REAR TORSION ARM, RIGHT, 13 1/4, 4 1/2"	003-6720	003-6721		
REAR TORSION ARM, RIGHT, 13 1/4, 5 1/4"	003-6726	003-6727		
TORSION STOP, 1 1/8", 1 3/4" SPLIT, STEEL	003-1588			
TORSION STOP, 1 1/8", 1 3/4" SPLIT, ALUM.	003-1590	003-1991		
TORSION STOP, 1 1/8", 2" SPLIT, STEEL	003-1593			
TORSION STOP, 1 1/8", 2" SPLIT, ALUM.	003-1595	003-1596		
LEFT STEERING ARM, COMBO	003-1909	003-1910		
RIGHT STEERING ARM	003-1921	003-1922		
PITMAN ARM, ANGLED, SHORT	003-1954	003-1955		
PITMAN ARM, ANGLED, LONG, 4 HOLE	003-1963	003-1964		
RADIUS ROD ADAPTER BRACKETS, PAIR	003-5712	003-5713		
SPRINT CAR FRONT AXLES	CHROME	BLACK		
FRONT AXLE, 2 1/2" X 50"	003-1811	003-1810		
FRONT AXLE, 2 1/2" X 50", LIGHTWEIGHT	003-1813	003-1812		
FRONT AXLE, 2 1/2" X 52"	003-1815	003-1814		
FRONT AXLE, 2 1/2" X 53"	003-1817	003-1816		
SPRINT CAR 5/8" RODS	ALUMINUM	CHROMOLY		
	POLISH	BLACK	CHROME	BLACK
RADIUS ROD TUBE, 17"	003-0902	003-0901		
RADIUS ROD TUBE, 17 1/2"	003-0904	003-0903		
RADIUS ROD TUBE, 18"	003-0906	003-0905		
RADIUS ROD TUBE, 18 1/2"	003-0908	003-0907		
RADIUS ROD TUBE, 19"	003-0910	003-0909		
RADIUS ROD TUBE, 19 1/2"	003-0912	003-0911		
RADIUS ROD TUBE, 20"	003-0914	003-0913		
RADIUS ROD TUBE, 20 1/2"	003-0916	003-0915		
RADIUS ROD TUBE, 21"	003-0918	003-0917		
RADIUS ROD TUBE, 21 1/2"	003-0920	003-0919		
RADIUS ROD TUBE, 22"	003-0922	003-0921		
RADIUS ROD TUBE, 22 1/2"	003-0924	003-0923		
RADIUS ROD TUBE, 23"	003-0926	003-0925		
RADIUS ROD TUBE, 23 1/2"	003-0928	003-0927		
RADIUS ROD TUBE, 24"	003-0930	003-0929		
RADIUS ROD TUBE, 24 1/2"	003-0932	003-0931		
RADIUS ROD TUBE, 25"	003-0934	003-0933		
RADIUS ROD TUBE, 25 1/2"	003-0936	003-0935		
RADIUS ROD, LONG BENT, 34"			003-5719	003-5718
RADIUS ROD, LONG BENT, 35"			003-5723	003-5722
DRAG/TIEROD TUBE, 44 3/4"	003-0952	003-0951	003-1002	003-1001
DRAG/TIEROD TUBE, 45"	003-0954	003-0953	003-1004	003-1003
DRAG/TIEROD TUBE, 45 3/4"	003-0956	003-0955	003-1006	003-1005
DRAG/TIEROD TUBE, 46"	003-0958	003-0957	003-1008	003-1007
DRAG/TIEROD TUBE, 46 3/4"	003-0960	003-0959	003-1010	003-1009
DRAG/TIEROD TUBE, 47"	003-0962	003-0961	003-1012	003-1011
DRAG/TIEROD TUBE, 47 3/4"	003-0964	003-0963	003-1014	003-1013
DRAG/TIEROD TUBE, 48"	003-0966	003-0965	003-1016	003-1015
DRAG/TIEROD TUBE, 48 3/4"	003-0968	003-0967	003-1018	003-1017
DRAG/TIEROD TUBE, 49"	003-0970	003-0969	003-1020	003-1019
DRAG/TIEROD TUBE, 49 3/4"	003-0972	003-0971	003-1022	003-1021
DRAG/TIEROD TUBE, 50"	003-0974	003-0973	003-1024	003-1023
DRAG/TIEROD TUBE, 51"	003-0978	003-0977	003-1028	003-1027
MIDGET	SILVER	BLACK		
REAR TORSION ARM, LEFT, STRAIGHT	002-6702	002-6703		
REAR TORSION ARM, RIGHT, BENT	002-6712	002-6713		
TORSION STOP, 1", 1 3/4" SPLIT, ALUMINUM	002-6750	002-6751		
PITMAN ARM, ANGLED, SHORT	003-1954	003-1955		
PITMAN ARM, ANGLED, LONG, 4 HOLE	003-1963	003-1964		
MIDGET FRONT AXLES	CHROME	BLACK		
FRONT AXLE, 2" X 44"	002-1799	002-1798		
MIDGET 5/8" RODS	ALUMINUM	CHROMOLY		
	POLISH	BLACK	CHROME	BLACK
RADIUS ROD/PANHARD, 17"	002-0912	002-0911		
RADIUS ROD TUBE, 28"	002-0956	002-0955		
RADIUS ROD TUBE, 28 1/2"	002-0958	002-0957		
RADIUS ROD TUBE, 29"	002-0960	002-0959		
RADIUS ROD TUBE, 29 1/2"	002-0962	002-0961		
RADIUS ROD TUBE, 30"	002-0964	002-0963		
RADIUS ROD TUBE, 30 1/2"	002-0966	002-0965		
RADIUS ROD TUBE, 31"	002-0968	002-0967		
RADIUS ROD TUBE, 31 1/2"	002-0970	002-0969		
DRAG/TIEROD TUBE, 38"	002-0996	002-0995	002-1085	002-1084
DRAG/TIEROD TUBE, 39"	002-1000	002-0999	002-1089	002-1088
DRAG/TIEROD TUBE, 40"	002-1004	002-1003	002-1093	002-1092
DRAG/TIEROD TUBE, 41"	002-1008	002-1007	002-1097	002-1096
600 MICRO-SPRINT	SILVER	BLACK		
LEFT FRONT SPINDLE	001-1170	001-1171		
RIGHT FRONT SPINDLE	001-1177	001-1178		
LEFT STEERING ARM	001-1913	001-1914		
RIGHT STEERING ARM	001-1919	001-1920		
FRONT TORSION ARM, LEFT	001-1211	001-1212		
FRONT TORSION ARM, RIGHT	001-1222	001-1223		
REAR TORSION ARM, LEFT	001-6210	001-6211		
REAR TORSION ARM, LEFT, LIGHTWEIGHT	001-6214	001-6215		
REAR TORSION ARM, RIGHT	001-6221	001-6222		
REAR TORSION ARM, RIGHT, LIGHTWEIGHT	001-6224	001-6225		
TORSION STOP, 7/8", 1 1/2" SPLIT, ALUMINUM	001-1202	001-1203		
600 MICRO-SPRINT	POLISH	BLACK		
DRAG LINK TUBE, ALUM, 3/8" X 14 1/2"	001-0918	001-0917		
RADIUS ROD/PANHARD, ALUM, 3/8" X 15 1/2"	001-0922	001-0921		
RADIUS ROD TUBE, ALUM, 7/16" X 19"	001-0982	001-0981		
RADIUS ROD TUBE, ALUM, 7/16" X 20"	001-0986	001-0985		
RADIUS ROD TUBE, ALUM, 7/16" X 21"	001-0990	001-0989		
RADIUS ROD TUBE, ALUM, 7/16" X 22"	001-0994	001-0993		
TIE ROD TUBE, ALUM, 3/8" X 36 1/2"	001-0952	001-0951		
600 MICRO-SPRINT	CHROME	BLACK		
TIE ROD TUBE, MOLY, 3/8" X 36 1/2"	001-1032	001-1031		
BRAKE ROD TUBE, MOLY, 7/16" X 20"	001-1066	001-1065		
FRONT AXLE, 1 1/2" X 40", TORSION-STYLE	001-1781	001-1780		
FRONT AXLE, 1 1/2" X 40", COILOVER-STYLE	001-1791	001-1790		

Place your order at (479) 646-6988, Fax to (479) 646-5939, or visit [www.southwestspeed.com](http://www.southwestspeed.com)

# BLACK MAGIC SMALL DIAMETER COILOVER SPRINGS



- ★COLD WOUND
- ★DOUBLE GROUND ENDS
- ★CHROME SILICONE WIRE
- ★METAL TAG WITH RATE

1 7/8" I.D. x 8" TALL			
RATE	PART #	RATE	PART #
50	015-005	175	015-017
60	015-006	200	015-020
75	015-007	225	015-022
90	015-009	250	015-025
105	015-010	275	015-027
120	015-012	300	015-030
135	015-013	325	015-032
150	015-015	350	015-035

1 7/8" I.D. x 10" TALL			
RATE	PART #	RATE	PART #
50	017-005	275	017-027
60	017-006	300	017-030
75	017-007	325	017-032
90	017-009	350	017-035
105	017-010	375	017-037
120	017-012	400	017-040
135	017-013	425	017-042
150	017-015	450	017-045
175	017-017	475	017-047
200	017-020	500	017-050
225	017-022	525	017-052
250	017-025	550	017-055

# Black Magic Spirings

"RUN WITH THE BLACK OR RUN IN THE BACK"

## PROGRESSIVE COILOVER SPRINGS

- ★COLD WOUND
- ★DOUBLE GROUND ENDS
- ★CHROME SILICONE WIRE
- ★METAL TAG WITH RATE
- ★LIFETIME GUARANTEE



RATE	I.D.	TALL	PART #
175/700	2 1/2"	11"	019-333

NOTE: FOR A CONSTANT STREAM OF NEW PRODUCTS & UP-TO-THE-SECOND PRICING, VISIT [WWW.SOUTHWESTSPEED.COM](http://WWW.SOUTHWESTSPEED.COM)

# BLACK MAGIC COILOVER SPRINGS



- ★COLD WOUND
- ★DOUBLE GROUND ENDS
- ★CHROME SILICONE WIRE
- ★METAL TAG WITH RATE
- ★UNMATCHED QUALITY
- ★LIFETIME GUARANTEE
- ★EXCLUSIVE DESIGN
- ★PROFESSIONAL RACER'S CHOICE

2 9/16" I.D. x 10" TALL			
RATE	PART #	RATE	PART #
125	018-012	375	018-037
150	018-015	400	018-040
175	018-017	425	018-042
200	018-020	450	018-045
225	018-022	475	018-047
250	018-025	500	018-050
275	018-027	525	018-052
300	018-030	550	018-055
325	018-032	575	018-057
350	018-035	600	018-060

2 9/16" I.D. x 12" TALL			
RATE	PART #	RATE	PART #
120	020-012	400	020-040
150	020-015	425	020-042
175	020-017	450	020-045
200	020-020	475	020-047
225	020-022	500	020-050
250	020-025	525	020-052
275	020-027	550	020-055
300	020-030	575	020-057
325	020-032	600	020-060
350	020-035	650	020-065
375	020-037	700	020-070

2 9/16" I.D. x 14" TALL			
RATE	PART #	RATE	PART #
100	022-010	225	022-022
120	022-012	250	022-025
150	022-015	275	022-027
175	022-017	300	022-030
200	022-020	325	022-032



NOTE: SOUTHWEST SPEED COILOVER KITS ARE ON PAGE 31.

Place your order at (479) 646-6988, Fax to (479) 646-5939, or visit [www.southwestspeed.com](http://www.southwestspeed.com)



# BLACK MAGIC EXTRA CLEARANCE COILOVER SPRINGS

- ★COLD WOUND
- ★DOUBLE GROUND ENDS
- ★CHROME SILICONE WIRE



2 9/16" I.D. X 12" TALL			
RATE	PART #	RATE	PART #
150	024-015	225	024-022
175	024-017	250	024-025
200	024-020		

NOTE: SOUTHWEST SPEED COILOVER KITS ARE ON PAGE 31.

# TORQUE-LINK SPRINGS

- ★DOUBLE GROUND ENDS
- ★AUTOMATIC WOUND
- ★EXCLUSIVE DESIGN



5" O.D. x 4" TALL			
RATE	PART #	RATE	PART #
500	028-050	1000	028-100
600	028-060	1100	028-110
700	028-070	1200	028-120
800	028-080		
900	028-090		

5" O.D. x 7" TALL			
RATE	PART #	RATE	PART #
500	031-050	1100	031-110
600	031-060	1200	031-120
700	031-070		
800	031-080		
900	031-090		
1000	031-100		



# COIL SPRING RUBBER SPACERS

- ★MEASUREMENTS FOR THE SPACERS ARE TAKEN BETWEEN THE COILS
- ★HELPS FINE TUNE CHASSIS
- ★QUICK SPRING RATE CHANGE
- ★EASY IN & OUT DESIGN
- ★FITS CONVENTIONAL 5" & 5 1/2" DIAMETER SPRINGS



DESCRIPTION	PART #
COIL SPRING RUBBER, 1/2"	050-808
COIL SPRING RUBBER, 3/4"	050-812
COIL SPRING RUBBER, 1"	050-816
COIL SPRING RUBBER, 1 1/2"	050-820
COIL SPRING RUBBER, 2"	050-822
COIL SPRING RUBBER, 2 1/2"	050-824

# BLACK MAGIC CONVENTIONAL REAR SPRINGS

- ★DOUBLE GROUND ENDS
- ★UNMATCHED PERFORMANCE, QUALITY, AND GUARANTEE



5" O.D. x 11" TALL			
RATE	PART #	RATE	PART #
100	035-010	275	035-027
125	035-012	300	035-030
150	035-015	325	035-032
175	035-017	350	035-035
200	035-020	375	035-037
225	035-022	400	035-040
250	035-025		

5" O.D. x 13" TALL			
RATE	PART #	RATE	PART #
100	037-010	275	037-027
125	037-012	300	037-030
150	037-015	325	037-032
175	037-017	350	037-035
200	037-020	375	037-037
225	037-022	400	037-040
250	037-025		

# CONVENTIONAL REAR SPRINGS

- ★DOUBLE GROUND ENDS
- ★METAL TAG WITH RATE
- ★UNMATCHED QUALITY, PERFORMANCE, & GUARANTEE



5" O.D. x 16" TALL			
RATE	PART #	RATE	PART #
100	039-010	225	039-022
125	039-012	250	039-025
150	039-015	275	039-027
175	039-017	300	039-030
200	039-020		

# REAR SPRING SEATS

- ★SPRING SEATS MOUNT 5" OR 5 1/2" REAR COIL SPRINGS TO THE REAR AXLE TUBE
- ★#520-096 & #520-097 PUT THE SPRING DIRECTLY ON TOP OF THE TUBE, WHILE #520-0965 PUTS IT JUST OFFSET OF THE TUBE

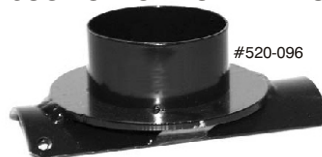

DESCRIPTION	PART #
REAR SPRING SEAT, WELD-ON	520-096
REAR SPRING SEAT, WELD-ON, OFFSET	520-0965
REAR SPRING SEAT, CLAMP-ON	520-097

Place your order at (479) 646-6988, Fax to (479) 646-5939, or visit [www.southwestspeed.com](http://www.southwestspeed.com)

# BLACK MAGIC PIGTAIL REAR SPRINGS

- ★ONE END WITH PIGTAIL TO FIT STOCK MOUNT, OTHER END FLAT
- ★AUTOMATIC WOUND
- ★METAL TAG WITH RATE



5 1/2" O.D. x 11" TALL			
RATE	PART #	RATE	PART #
175	040-017	275	040-027
200	040-020	300	040-030
225	040-022	325	040-032
250	040-025	350	040-035

# CONVENTIONAL STREET STOCK FRONT SPRINGS

- ★NO SPACERS NEEDED
- ★MAINTAINS RIDE HEIGHT
- ★METAL TAG WITH RATE



5 1/2" O.D. x 12" TALL			
RATE	PART #	RATE	PART #
800	050-080	1200	050-120
900	050-090	1300	050-130
1000	050-100	1400	050-140
1100	050-110		

# COIL SPRING SPACERS

## TRIM TO FIT

- ★FITS 5" OR 5 1/2" SPRING
- ★ALLOWS STOCK SHOCK TO BE USED
- ★TRIM TO ADJUST RIDE HEIGHT
- ★UP TO 3 1/4" ADJUSTMENT



**PART #051-240**

## ADJUSTABLE

- ★FAST ACME THREADS; ISOLATES SPRING FROM THREADS TO PREVENT THREAD CHAFING
- ★READY TO INSTALL; 5" OR 5 1/2" SPRINGS



DESCRIPTION	PART #
ADJUSTABLE SPACER, 2" - 3 1/2"	051-242
FLAT ADJ. SPACER, 1/4" - 2 1/4"	051-2430
FLAT ADJ. SPACER, 1/4" - 4 1/4"	051-2435

# BLACK MAGIC CONVENTIONAL FRONT SPRINGS

- ★ONE END LEFT OPEN TO FIT A-ARM
- ★METAL TAG WITH RATE



5" O.D. x 8" TALL			
RATE	PART #	RATE	PART #
500	032-050	800	032-080
600	032-060	900	032-090
700	032-070	1000	032-100

5" O.D. X 9 1/2" TALL			
RATE	PART #	RATE	PART #
500	033-050	1000	033-100
550	033-055	1050	033-105
600	033-060	1100	033-110
650	033-065	1200	033-120
700	033-070	1300	033-130
750	033-075	1400	033-140
800	033-080	1500	033-150
850	033-085	1600	033-160
900	033-090	1800	033-180
950	033-095		

5 1/2" O.D. x 8 1/2" TALL			
RATE	PART #	RATE	PART #
500	045-050	900	045-090
550	045-055	950	045-095
600	045-060	1000	045-100
650	045-065	1050	045-105
700	045-070	1100	045-110
750	045-075	1150	045-115
800	045-080	1200	045-120
850	045-085		

5 1/2" O.D. x 9 1/2" TALL			
RATE	PART #	RATE	PART #
500	046-050	1000	046-100
550	046-055	1050	046-105
600	046-060	1100	046-110
650	046-065	1200	046-120
700	046-070	1300	046-130
750	046-075	1400	046-140
800	046-080	1500	046-150
850	046-085	1600	046-160
900	046-090	1800	046-180
950	046-095		

- \* 5" { 64-72 CHEVELLE  
67-69 CAMARO  
68-74 NOVA
  - \* 5 1/2" { 73-UP CHEVELLE  
70-UP CAMARO  
75-UP NOVA  
MOST FORDS
- \* FRONT SPRING DIAMETER



Place your order at (479) 646-6988, Fax to (479) 646-5939, or visit [www.southwestspeed.com](http://www.southwestspeed.com)



# 1" COARSE ECONOMY WEIGHT JACK KITS

- ★1" COARSE THREADED BOLTS
- ★AVAILABLE WITH EITHER STANDARD OR LIGHTWEIGHT STEEL PLATES
- ★SLIP-FIT DESIGN ALLOWS FOR MISALIGNMENT
- ★FITS 5" & 5 1/2" OUTSIDE DIAMETER SPRINGS
- ★ADJUSTED WITH 1/2" SQUARE HEX IN BOLTS
- ★KITS INCLUDE: \*UNIVERSAL SLIP-FIT PLATE (STANDARD OR LIGHTWEIGHT), \*ALUMINUM OR STEEL BOLT (4" - 11" LONG), & \*WELD NUT WITH GREASE FITTING

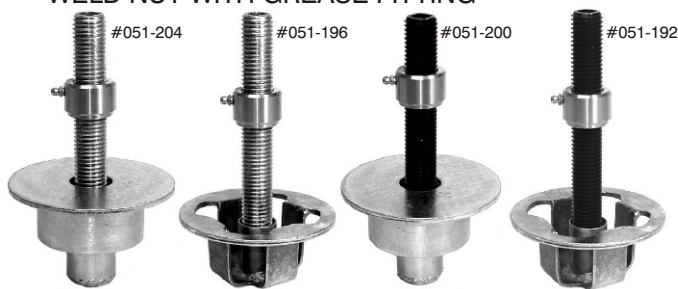

COMPLETE ASSEMBLY	BOLT TYPE	
	ALUM.	STEEL
4" ECONOMY W.J. KIT	-	051-203
4" ECONOMY W.J. KIT, LIGHT	-	051-195
5" ECONOMY W.J. KIT	-	051-2034
5" ECONOMY W.J. KIT, LIGHT	-	051-1954
6" ECONOMY W.J. KIT	-	051-2035
6" ECONOMY W.J. KIT, LIGHT	-	051-1955
8" ECONOMY W.J. KIT	051-200	051-204
8" ECONOMY W.J. KIT, LIGHT	051-192	051-196
11" ECONOMY W.J. KIT	051-202	051-206
11" ECONOMY W.J. KIT, LIGHT	051-194	051-198

# 1" COARSE WEIGHT JACK BOLTS ONLY

- ★ALL BOLTS WILL SLIP INTO ECONOMY PLATES
- ★\*\*\*IN ADDITION, THE 5", 6", & 8" STEEL BOLTS HAVE A 7/16"-20 THREADED HOLE IN THE END, ALLOWING THEM TO BE ATTACHED TO BOLT-ON WEIGHT JACK PLATES WITH A RETAINER BOLT; THIS ALLOWS THOSE 3 BOLTS TO BE USED WITH ANY SOUTHWEST SPEED W.J. PLATE
- ★8" & 11" ALUMINUM & 4" & 11" STEEL BOLTS ARE ADJUSTED WITH 1/2" SQUARE HEX IN THE END
- ★\*\*\*5", 6", & 8" STEEL BOLTS ARE ADJUSTED WITH 5/8" HEX ON THE END USING A 5/8" WRENCH OR SOCKET

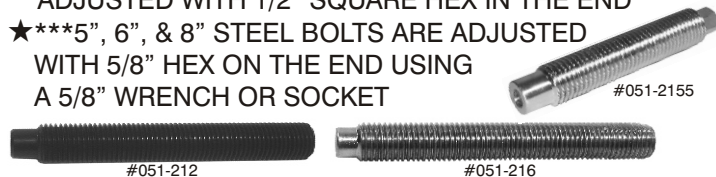

DESCRIPTION	PART #
1" COARSE BOLT, 8" LONG, ALUMINUM	051-212
1" COARSE BOLT, 11" LONG, ALUMINUM	051-214
1" COARSE BOLT, 4" LONG, STEEL	051-215
1" COARSE BOLT, 5" LONG, STEEL***	051-2154
1" COARSE BOLT, 6" LONG, STEEL***	051-2155
1" COARSE BOLT, 8" LONG, STEEL***	051-216
1" COARSE BOLT, 11" LONG, STEEL	051-218

# 1" COARSE WEIGHT JACK KITS W/ BOLT-ON PLATES

- ★1" COARSE THREADED BOLTS
- ★WEIGHT JACK BOLT BOLTS DIRECTLY TO THE PLATE WITH RETAINER BOLT (INCLUDED)
- ★AVAILABLE WITH EITHER STANDARD STEEL, LIGHTWEIGHT STEEL, OR ALUMINUM PLATES TO FIT EITHER 5" OR 5 1/2" OUTSIDE DIAM. SPRINGS
- ★THERE ARE 2 SEPARATE ALUM. PLATES FOR 5" FRONT & 5" REAR SPRINGS TO ACCOUNT FOR THE THICKER WIRE ON FRONT SPRINGS
- ★ADJUSTED WITH 5/8" HEX ON BOLTS USING A 5/8" WRENCH OR SOCKET

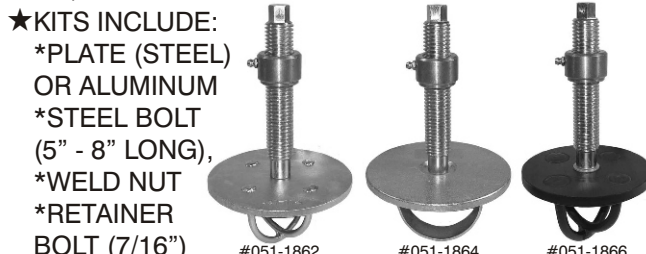

COMPLETE ASSY.	PLATE TYPE	SPRING O.D.	STEEL BOLT
5" ECON. KIT	LW STEEL	5"	051-1851
5" ECON. KIT	LW STEEL	5 1/2"	051-1852
5" ECON. KIT	STEEL	5"	051-1853
5" ECON. KIT	STEEL	5 1/2"	051-1854
5" ECON. KIT, FRONT	ALUMINUM	5"	051-1855
5" ECON. KIT, REAR	ALUMINUM	5"	051-1856
5" ECON. KIT	ALUMINUM	5 1/2"	051-1857
6" ECON. KIT	LW STEEL	5"	051-1861
6" ECON. KIT	LW STEEL	5 1/2"	051-1862
6" ECON. KIT	STEEL	5"	051-1863
6" ECON. KIT	STEEL	5 1/2"	051-1864
6" ECON. KIT, FRONT	ALUMINUM	5"	051-1865
6" ECON. KIT, REAR	ALUMINUM	5"	051-1866
6" ECON. KIT	ALUMINUM	5 1/2"	051-1867
8" ECON. KIT	LW STEEL	5"	051-1881
8" ECON. KIT	LW STEEL	5 1/2"	051-1882
8" ECON. KIT	STEEL	5"	051-1883
8" ECON. KIT	STEEL	5 1/2"	051-1884
8" ECON. KIT, FRONT	ALUMINUM	5"	051-1885
8" ECON. KIT, REAR	ALUMINUM	5"	051-1886
8" ECON. KIT	ALUMINUM	5 1/2"	051-1887

# ECONOMY WEIGHT JACK PLATES ONLY

- ★SLIP-FIT DESIGN ALLOWS FOR MISALIGNMENT
- ★#051-219 & #051-220 WILL FIT BOTH 5" & 5 1/2" DIAMETER SPRINGS; #051-222 IS FOR PIGTAILS



DESCRIPTION	PART #
ECONOMY PLATE, LIGHTWEIGHT	051-219
ECONOMY PLATE, STANDARD	051-220
ECONOMY PLATE, PIGTAIL SPRING	051-222

Place your order at (479) 646-6988, Fax to (479) 646-5939, or visit [www.southwestspeed.com](http://www.southwestspeed.com)

# 1 1/8" FINE WEIGHT JACK KITS

- ★1 1/8" FINE THREADED BOLTS
- ★WEIGHT JACK BOLT BOLTS DIRECTLY TO THE PLATE WITH RETAINER BOLT (INCLUDED)
- ★AVAILABLE WITH STANDARD OR LIGHTWEIGHT STEEL PLATES TO FIT EITHER 5" OR 5 1/2" OUTSIDE DIAMETER SPRINGS
- ★ADJUSTED WITH 1/2" SQUARE HEX IN BOLTS
- ★KITS INCLUDE: \*5" OR 5 1/2" STEEL PLATE (STANDARD OR LIGHTWEIGHT), \*ALUMINUM OR STEEL BOLT (4" - 8" LONG), \*WELD NUT, & \*7/16" RETAINER BOLT



COMPLETE ASSY.	SPRING O.D.	BOLT TYPE	
		ALUM.	STEEL
4" W.J. KIT	5"	051-050	051-062
4" W.J. KIT, LIGHT	5"	051-026	051-038
4" W.J. KIT	5 1/2"	051-056	051-068
4" W.J. KIT, LIGHT	5 1/2"	051-032	051-044
5" W.J. KIT	5"	-	051-063
5" W.J. KIT, LIGHT	5"	-	051-039
5" W.J. KIT	5 1/2"	-	051-069
5" W.J. KIT, LIGHT	5 1/2"	-	051-045
6" W.J. KIT	5"	051-052	051-064
6" W.J. KIT, LIGHT	5"	051-028	051-040
6" W.J. KIT	5 1/2"	051-058	051-070
6" W.J. KIT, LIGHT	5 1/2"	051-034	051-046
8" W.J. KIT	5"	051-054	051-066
8" W.J. KIT, LIGHT	5"	051-030	051-042
8" W.J. KIT	5 1/2"	051-060	051-072
8" W.J. KIT, LIGHT	5 1/2"	051-036	051-048

## 1 1/8" FINE WEIGHT JACK BOLTS ONLY

- ★ALL BOLTS HAVE A 7/16"-20 THREADED HOLE IN THE END, ALLOWING THEM TO BE ATTACHED TO BOLT-ON WEIGHT JACK PLATES WITH A RETAINER BOLT

- ★ADJUSTED WITH 1/2" SQUARE HEX IN THE END



DESCRIPTION	PART #
1 1/8" FINE BOLT, 4" LONG, ALUMINUM	051-100
1 1/8" FINE BOLT, 6" LONG, ALUMINUM	051-102
1 1/8" FINE BOLT, 8" LONG, ALUMINUM	051-104
1 1/8" FINE BOLT, 4" LONG, STEEL	051-106
1 1/8" FINE BOLT, 5" LONG, STEEL	051-155
1 1/8" FINE BOLT, 6" LONG, STEEL	051-108
1 1/8" FINE BOLT, 8" LONG, STEEL	051-110
7/16" RETAINER BOLT FOR ALUM. W.J.	051-097
7/16" RETAINER BOLT FOR STEEL W.J.	051-099

# 1 1/8" FINE WEIGHT JACK KITS - WITH ALUM. PLATES

- ★1 1/8" FINE THREADED BOLTS
- ★WEIGHT JACK BOLT BOLTS DIRECTLY TO THE PLATE WITH RETAINER BOLT (INCLUDED)
- ★AVAILABLE WITH ALUMINUM PLATES TO FIT EITHER 5" OR 5 1/2" OUTSIDE DIA. SPRINGS
- ★THERE ARE 2 SEPARATE PLATES FOR 5" FRONT SPRINGS & 5" REAR SPRINGS TO ACCOUNT FOR THE THICKER WIRE ON FRONT SPRINGS
- ★ADJUSTED WITH 1/2" SQUARE HEX IN BOLTS
- ★KITS INCLUDE: \*5" OR 5 1/2" (FRONT OR REAR ON THE 5"), \*ALUMINUM OR STEEL BOLT (4" - 8" LONG), \*WELD NUT, \*7/16" RETAINER BOLT, & \*7/16" WASHER TO GO BETWEEN PLATE & BOLT



COMPLETE ASSY.	SPRING O.D.	BOLT TYPE	
		ALUM.	STEEL
4" W.J. KIT, FRONT	5"	051-075	051-087
4" W.J. KIT, REAR	5"	051-074	051-086
4" W.J. KIT	5 1/2"	051-080	051-092
5" W.J. KIT, FRONT	5"	-	051-0875
5" W.J. KIT, REAR	5"	-	051-0871
5" W.J. KIT	5 1/2"	-	051-093
6" W.J. KIT, FRONT	5"	051-077	051-089
6" W.J. KIT, REAR	5"	051-076	051-088
6" W.J. KIT	5 1/2"	051-082	051-094
8" W.J. KIT, FRONT	5"	051-079	051-091
8" W.J. KIT, REAR	5"	051-078	051-090
8" W.J. KIT	5 1/2"	051-084	051-096

## BOLT-ON WEIGHT JACK PLATES ONLY

- ★DESIGNED TO BOLT TO WEIGHT JACK BOLTS WITH THE 7/16" THREADED HOLE IN THE END
- ★AVAILABLE IN STEEL, LIGHTWEIGHT STEEL, & ALUMINUM FOR BOTH 5" & 5 1/2" O.D. SPRINGS
- ★THERE ARE 2 SEPARATE ALUM. PLATES FOR 5" FRONT & 5" REAR SPRINGS TO ACCOUNT FOR THE THICKER WIRE ON FRONT SPRINGS



DESCRIPTION	PART #
W.J. PLATE, STEEL, 5" SPRING	051-116
W.J. PLATE, STEEL, 5 1/2" SPRING	051-118
W.J. PLATE, LIGHT. STEEL, 5" SPRING	051-112
W.J. PLATE, LIGHT. STEEL, 5 1/2" SPRING	051-114
W.J. PLATE, ALUMINUM, 5" FRONT SPRG.	051-119
W.J. PLATE, ALUMINUM, 5" REAR SPRING	051-120
W.J. PLATE, ALUMINUM, 5 1/2" SPRING	051-122

Place your order at (479) 646-6988, Fax to (479) 646-5939, or visit [www.southwestspeed.com](http://www.southwestspeed.com)



# 1" COARSE WEIGHT JACK NUTS

- ★ 1" COARSE NUTS
- ★ AVAILABLE IN WELD-ON & CLAMP-ON



DESCRIPTION	PART #
WELD-ON WEIGHT JACK NUT	051-210
WELD-ON WEIGHT JACK NUT, LONG	051-209
CLAMP-ON: 1 1/2" VERTICAL TUBING	051-228
CLAMP-ON: 1 1/2" HORIZONTAL TUBING	051-229

# 1 1/8" FINE WEIGHT JACK WELD NUTS

- ★ 1 1/8" FINE THREADED NUTS
- ★ 1 3/8" LONG
- ★ AVAILABLE WITH OR WITHOUT LIP



DESCRIPTION	PART #
WELD-ON 1 1/8" FINE NUT	051-098
WELD-ON 1 1/8" FINE NUT WITHOUT LIP	051-148

# HIDDEN WEIGHT JACKS TRIM TO FIT

- ★ FITS 5" OR 5 1/2" SPRING
- ★ ALLOWS STOCK SHOCK TO BE USED
- ★ TRIM TO ADJUST RIDE HEIGHT
- ★ UP TO 3 1/4" ADJUSTMENT



## ADJUSTABLE

- ★ FAST ACME THREADS; ISOLATES SPRING FROM THREADS TO PREVENT THREAD CHAFING



DESCRIPTION	PART #
ADJUSTABLE SPACER, 2" - 3 1/2"	051-242
FLAT ADJ. SPACER, 1/4" - 2 1/4"	051-2430
FLAT ADJ. SPACER, 1/4" - 4 1/4"	051-2435

# WEIGHT JACK JAM NUTS

- ★ LOCKS WEIGHT JACK IN PLACE QUICKLY
- ★ LIGHTWEIGHT ALUMINUM & STEEL AVAILABLE

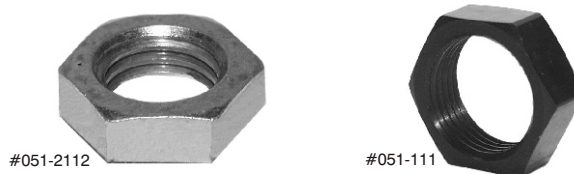

DESCRIPTION	PART #
1" COARSE JAM NUT, ALUMINUM	051-211
1" COARSE JAM NUT, STEEL	051-2112
1 1/8" FINE JAM NUT, ALUMINUM	051-111
1 1/8" FINE JAM NUT, STEEL	051-1112

# WEIGHT JACK FRAME PLATES

- ★ 5" O.D. ON #051-230 & 5 1/4" O.D. ON THE OTHER PLATES
- ★ WELDS TO CHASSIS TO INSTALL WEIGHT JACKS
- ★ #051-231 IS MADE SO THE LIP OF THE COARSE THREAD NUT (#051-210) DROPS IN
- ★ #051-232 IS MADE SO THE LIP OF THE FINE THREAD NUT (#051-098) DROPS IN

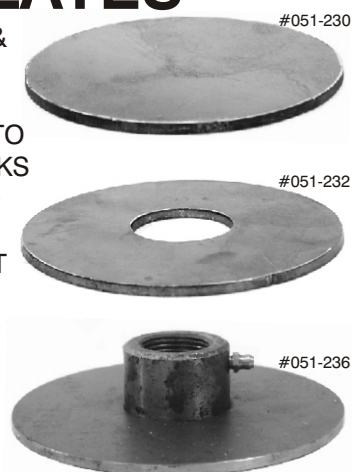

DESCRIPTION	PART #
BLANK PLATE WITH NO HOLE	051-230
PLATE WITH 1 3/8" HOLE	051-231
PLATE WITH 1 5/8" HOLE	051-232
PLATE & NUT, 1" COARSE THREAD	051-234
PLATE & NUT, 1 1/8" FINE THREAD	051-236

# COIL SPRING BUCKETS

- ★ WELDS IN FRAME FOR WEIGHT JACKS
- ★ EASILY FITS 5" OR 5 1/2" SPRING
- ★ 5 1/4" TALL



DESCRIPTION	PART #
SPRING BUCKET, 1" COARSE NUT	520-099
SPRING BUCKET, 1 1/8" FINE NUT	520-100

NOTE: FOR A CONSTANT STREAM OF NEW PRODUCTS & UP-TO-THE-SECOND PRICING, VISIT [WWW.SOUTHWESTSPEED.COM](http://WWW.SOUTHWESTSPEED.COM)

Place your order at (479) 646-6988, Fax to (479) 646-5939, or visit [www.southwestspeed.com](http://www.southwestspeed.com)

# SHOCK # SYSTEM

SHOCK COMPANIES OFTEN USE DIFFERENT NUMBERING SYSTEMS REGARDING THE REBOUND & COMPRESSION, WHICH MAKES IT DIFFICULT FOR CUSTOMERS TO UNDERSTAND. WE HAVE CREATED A CHART TO TRY & MAKE THIS EASIER.

PRO=COMPRESSION THEN REBOUND  
 KONI=COMPRESSION THEN REBOUND  
 BILSTEIN=REBOUND THEN COMPRESSION  
 CARRERA=REBOUND THEN COMPRESSION

EXAMPLE:

7" FIXED BEARING SHOCK W/ 5 COMPRESSION & 3 REBOUND=

PRO KONI BILSTEIN CARRERA  
 WB753 30-7514\* S7Z-3050 2173/5  
 \*REBOUND ADJUSTABLE 1 THROUGH 4

# PRO SHOCKS TAKE APARTS W/ BEARINGS

★TAKE APART GAS SHOCKS COME WITH 2 REMOVABLE BEARINGS

★7" = 12 1/2" COMPRESSED, 19 1/2" EXTENDED

★9" = 14 1/2" COMPRESSED, 23 1/2" EXTENDED

VALVE		RATE		TRA- VEL	PART #
OUT	IN	OUT	IN		
2	2	125 LB	125 LB	7"	PRO TA7200B
3	2	155 LB	125 LB	7"	PRO TA7230B
3	3	155 LB	155 LB	7"	PRO TA7300B
5	3	260 LB	155 LB	7"	PRO TA7350B
6	3	315 LB	155 LB	7"	PRO TA7360B
7	3	370 LB	155 LB	7"	PRO TA7370B
4	4	210 LB	210 LB	7"	PRO TA7400B
5	4	260 LB	210 LB	7"	PRO TA7450B
6	4	315 LB	210 LB	7"	PRO TA7460B
5	5	260 LB	260 LB	7"	PRO TA7500B
3	5	155 LB	260 LB	7"	PRO TA7530B
6	5	315 LB	260 LB	7"	PRO TA7560B
6	6	315 LB	315 LB	7"	PRO TA7600B
2	6	125 LB	315 LB	7"	PRO TA7620B
3	6	155 LB	315 LB	7"	PRO TA7630B
4	6	210 LB	315 LB	7"	PRO TA7640B
7	7	370 LB	370 LB	7"	PRO TA7700B
3	7	155 LB	370 LB	7"	PRO TA7730B
8	8	480 LB	370 LB	7"	PRO TA7800B
1	9	60 LB	600 LB	7"	PRO TA7910B
2	2	125 LB	125 LB	9"	PRO TA9200B
5	2	260 LB	125 LB	9"	PRO TA9250B
3	3	155 LB	155 LB	9"	PRO TA9300B
5	3	260 LB	155 LB	9"	PRO TA9350B
6	3	315 LB	155 LB	9"	PRO TA9360B
8	3	480 LB	155 LB	9"	PRO TA9380B
4	4	210 LB	210 LB	9"	PRO TA9400B
6	4	315 LB	210 LB	9"	PRO TA9460B
5	5	260 LB	260 LB	9"	PRO TA9500B
3	5	155 LB	260 LB	9"	PRO TA9530B
6	5	315 LB	260 LB	9"	PRO TA9560B
6	6	315 LB	315 LB	9"	PRO TA9600B
1	6	60 LB	315 LB	9"	PRO TA9610B
2	6	125 LB	315 LB	9"	PRO TA9620B
4	6	210 LB	315 LB	9"	PRO TA9640B
7	7	370 LB	370 LB	9"	PRO TA9700B
2	7	125 LB	370 LB	9"	PRO TA9720B
8	8	480 LB	370 LB	9"	PRO TA9800B
2	8	125 LB	480 LB	9"	PRO TA9820B

AVAILABLE W/O BEARINGS, JUST TAKE "B" OFF PART #

FOR 2 1/2" I.D. SPRINGS, USE COILOVER KIT #180-024 (5" SLEEVE)

OR #180-025 (7" SLEEVE). FOR 5" O.D. SPRINGS, USE COILOVER KIT

#179-974 (5" SLEEVE) OR #179-9752 (7" SLEEVE)

# SHOCK EXTENSIONS

★USED ON ALL PRO BIG BODY SHOCKS, INCLUDING TAKE APART, PRO GAS, ALUM. SMOOTH & THREADED  
 1" #PRO C510  
 2" #PRO C520

# PRO SHOCKS WELDED BEARING

★COMES WITH 2 FIXED BEARINGS

★7" = 12 3/8" COMPRESSED, 19 3/8" EXTENDED

★9" = 14 3/8" COMPRESSED, 23 3/8" EXTENDED



VALVE		RATE		TRA- VEL	PART #
OUT	IN	OUT	IN		
5	3	260 LB	155 LB	7"	PRO WB735
4	4	210 LB	210 LB	7"	PRO WB74
6	4	315 LB	210 LB	7"	PRO WB746
5	5	260 LB	260 LB	7"	PRO WB75
3	5	155 LB	260 LB	7"	PRO WB753
6	6	315 LB	315 LB	7"	PRO WB76
3	6	155 LB	315 LB	7"	PRO WB763
7	7	370 LB	370 LB	7"	PRO WB77
8	8	480 LB	370 LB	7"	PRO WB78
1	9	60 LB	600 LB	7"	PRO WB791
3	3	155 LB	155 LB	9"	PRO WB93
5	3	260 LB	155 LB	9"	PRO WB935
4	4	210 LB	210 LB	9"	PRO WB94
6	4	315 LB	210 LB	9"	PRO WB946
5	5	260 LB	260 LB	9"	PRO WB95
3	5	155 LB	260 LB	9"	PRO WB953
6	6	315 LB	315 LB	9"	PRO WB96
7	7	370 LB	370 LB	9"	PRO WB97

FOR 2 1/2" I.D. SPRINGS, USE COILOVER KIT #180-024 (5" SLEEVE) OR #180-025 (7" SLEEVE). FOR 5" O.D. SPRINGS, USE COILOVER KIT #179-974 (5" SLEEVE) OR #179-9752 (7" SLEEVE)

\*WB SHOCKS MUST BE GROOVED FOR COILOVER KIT SNAP RING

# PRO GAS SHOCKS

★PRO'S GAS CHARGED, MONO-TUBE SHOCK

★COMES WITH 1 FIXED & 1 REMOVABLE BEARING

★7" = 12 3/8" COMPRESSED, 19 3/8" EXTENDED

★9" = 14 3/8" COMPRESSED, 23 3/8" EXTENDED

VALVE		RATE		TRA- VEL	PART #
OUT	IN	OUT	IN		
3	3	155 LB	155 LB	7"	PRO PG730B
5	3	260 LB	155 LB	7"	PRO PG735B
4	4	210 LB	210 LB	7"	PRO PG740B
6	4	315 LB	210 LB	7"	PRO PG746B
5	5	260 LB	260 LB	7"	PRO PG750B
3	5	155 LB	260 LB	7"	PRO PG753B
6	6	315 LB	315 LB	7"	PRO PG760B
3	3	155 LB	155 LB	9"	PRO PG930B
5	3	260 LB	155 LB	9"	PRO PG935B
4	4	210 LB	210 LB	9"	PRO PG940B
6	4	315 LB	210 LB	9"	PRO PG946B
5	5	260 LB	260 LB	9"	PRO PG950B
3	5	155 LB	260 LB	9"	PRO PG953B
6	6	315 LB	315 LB	9"	PRO PG960B
2	7	125 LB	370 LB	9"	PRO PG972B

FOR 2 1/2" I.D. SPRINGS, USE COILOVER KIT #180-024 (5" SLEEVE) OR #180-025 (7" SLEEVE). FOR 5" O.D. SPRINGS, USE COILOVER KIT #179-974 (5" SLEEVE) OR #179-9752 (7" SLEEVE)

# STOCK MOUNT SHOCK ENDS

★SHOCK ENDS WILL GO ON ANY PRO BIG BODY SHOCKS, 9/16" THREAD



DESCRIPTION	PART #
RUBBER 1/2" I.D. EYE-RING ASSEMBLY	PRO S500
STUD MOUNT ASSEMBLY	PRO S506
GM FRONT BAR ASSEMBLY	PRO S512
GM REAR BAR ASSEMBLY	PRO S514
1/2" I.D. SLEEVE ONLY	PRO S501

Place your order at (479) 646-6988, Fax to (479) 646-5939, or visit [www.southwestspeed.com](http://www.southwestspeed.com)



# PRO ALUMINUM BIG BODY SHOCKS

★AVAILABLE IN SMOOTH BODY & THREADED BODY, EACH COMES WITH 1 FIXED & 1 REMOVABLE BEARING  
 ★IN THE SMOOTH BODY, WE HAVE REBOUND ADJUSTABLE SHOCKS & IN THE THREADED BODY, WE HAVE REBOUND & COMPRESSION ADJUSTABLE



REBOUND IS ADJUSTED USING AN ALLEN-HEAD SCREW ON THE BOTTOM



COMPRESSION IS ADJUSTED USING A THUMB WHEEL ON THE TOP

- ★6" = 11 1/2" COMPRESSED, 17 1/2" EXTENDED
- ★7" = 12 1/2" COMPRESSED, 19 1/2" EXTENDED
- ★8" = 13 1/2" COMPRESSED, 21 1/2" EXTENDED
- ★9" = 14 1/2" COMPRESSED, 23 1/2" EXTENDED
- ★7" DOUBLE ADJ. = 13 1/2" COMP, 20" EXTEND
- ★8" REBOUND ADJ. = 14" COMP, 21 1/2" EXT.
- ★9" DOUBLE ADJ. = 15 1/2" COMP, 24" EXTEND

## ALUMINUM SMOOTH BIG BODY

VALVE		RATE		TRA-VEL	PART #
OUT	IN	OUT	IN		
4	4	210 LB	210 LB	6"	PRO A640B
5	4	260 LB	210 LB	6"	PRO A645B
6	4	315 LB	210 LB	6"	PRO A646B
5	5	260 LB	260 LB	6"	PRO A650B
2	5	125 LB	260 LB	6"	PRO A652B
3	5	155 LB	260 LB	6"	PRO A653B
3	3	155 LB	155 LB	7"	PRO A730B
4	4	210 LB	210 LB	7"	PRO A740B
5	4	260 LB	210 LB	7"	PRO A745B
6	4	315 LB	210 LB	7"	PRO A746B
7	4	370 LB	210 LB	7"	PRO A747B
5	5	260 LB	260 LB	7"	PRO A750B
1	5	60 LB	260 LB	7"	PRO A751B
2	5	125 LB	260 LB	7"	PRO A752B
3	5	155 LB	260 LB	7"	PRO A753B
4	5	210 LB	260 LB	7"	PRO A754B
7	5	370 LB	260 LB	7"	PRO A757B
6	6	315 LB	315 LB	7"	PRO A760B
3	6	155 LB	315 LB	7"	PRO A763B
4	6	210 LB	315 LB	7"	PRO A764B
7	7	370 LB	370 LB	7"	PRO A770B
8	8	480 LB	370 LB	7"	PRO A780B
1	9	60 LB	600 LB	7"	PRO A791B
6-11	3	*	155 LB	8"	PRO A836-11B
8	3	480 LB	155 LB	8"	PRO A838B
9	3	600 LB	155 LB	8"	PRO A839B
3-8	4	**	210 LB	8"	PRO A843-8B
6-11	4	***	210 LB	8"	PRO A846-11B
8	4	480 LB	210 LB	8"	PRO A848B
3	3	155 LB	155 LB	9"	PRO A930B
5	3	260 LB	155 LB	9"	PRO A935B
8	3	480 LB	155 LB	9"	PRO A938B
4	4	210 LB	210 LB	9"	PRO A940B
6	4	315 LB	210 LB	9"	PRO A946B
7	4	370 LB	210 LB	9"	PRO A947B
8	4	480 LB	210 LB	9"	PRO A948B
4.5	4.5	235 LB	235 LB	9"	PRO A94.5B
5	5	260 LB	260 LB	9"	PRO A950B
3	5	155 LB	260 LB	9"	PRO A953B
6	5	315 LB	260 LB	9"	PRO A956B
6	5	315 LB	260 LB	9"	PRO A956TB
6	6	315 LB	315 LB	9"	PRO A960B
7	7	370 LB	370 LB	9"	PRO A970B
8	8	480 LB	370 LB	9"	PRO A980B

\*A836-11B IS 315 LB - 950 LB OUT & 155 LB IN  
 \*\*A843-8B IS 155 LB - 480 LB OUT & 210 LB IN  
 \*\*\*A846-11B IS 315 LB - 950 LB OUT & 210 LB IN  
 FOR 2 1/2" I.D. SPRINGS, USE COILOVER KIT #180-024 (5" SLEEVE)  
 OR #180-025 (7" SLEEVE). FOR 5" O.D. SPRINGS, USE COILOVER KIT #179-974 (5" SLEEVE) OR #179-9752 (7" SLEEVE)

## BIG BODY BEARINGS

- ★1/2" BORE, 9/16" SHAFT
- ★STEEL & ALUMINUM ROD ENDS AVAILABLE
- ★FITS PRO GAS, TAKE-APART, BIG BODY ALUM. SMOOTH & THREADED



STEEL #  
PRO WB200  
ALUM #  
PRO B200

## ALUMINUM THREADED BIG BODY

VALVE		RATE		TRA-VEL	PART #
OUT	IN	OUT	IN		
3	3	155 LB	155 LB	7"	PRO AC730B
5	3	260 LB	155 LB	7"	PRO AC735B
3-8	3-7	*	*	7"	PRO AC73738B
4	4	210 LB	210 LB	7"	PRO AC740B
6	4	315 LB	210 LB	7"	PRO AC746B
5	5	260 LB	260 LB	7"	PRO AC750B
1	5	60 LB	260 LB	7"	PRO AC751B
2	5	125 LB	260 LB	7"	PRO AC752B
3	5	155 LB	260 LB	7"	PRO AC753B
4	5	210 LB	260 LB	7"	PRO AC754B
7	5	370 LB	260 LB	7"	PRO AC757B
6	6	315 LB	315 LB	7"	PRO AC760B
3	6	155 LB	315 LB	7"	PRO AC763B
4	6	210 LB	315 LB	7"	PRO AC764B
5	6	260 LB	315 LB	7"	PRO AC765B
7	7	370 LB	370 LB	7"	PRO AC770B
8	8	480 LB	370 LB	7"	PRO AC780B
1	9	60 LB	600 LB	7"	PRO AC791B
3	3	155 LB	155 LB	9"	PRO AC930B
5	3	260 LB	155 LB	9"	PRO AC935B
8	3	480 LB	155 LB	9"	PRO AC938B
3-8	3-7	**	**	9"	PRO AC93738B
4	4	210 LB	210 LB	9"	PRO AC940B
6	4	315 LB	210 LB	9"	PRO AC946B
7	4	370 LB	210 LB	9"	PRO AC947B
4.5	4.5	235 LB	235 LB	9"	PRO AC94.5B
5	5	260 LB	260 LB	9"	PRO AC950B
3	5	155 LB	260 LB	9"	PRO AC953B
6	5	315 LB	260 LB	9"	PRO AC956B
6	5	315 LB	260 LB	9"	PRO AC956TB
5.5	5.5	290 LB	290 LB	9"	PRO AC95.5B
6	6	315 LB	315 LB	9"	PRO AC960B
2	6	125 LB	315 LB	9"	PRO AC962B
7	7	370 LB	370 LB	9"	PRO AC970B
2	7	125 LB	370 LB	9"	PRO AC972B
8	8	480 LB	370 LB	9"	PRO AC980B

\*AC73738B IS 155 LB - 480 LB OUT & 155 LB - 370 LB IN  
 \*\*AC93738B IS 155 LB - 480 LB OUT & 155 LB - 370 LB IN  
 FOR 2 1/2" I.D. SPRINGS, USE COILOVER KIT #180-0255

## REMOTE REBOUND ADJUSTER

★ALLOWS DRIVER TO CHANGE THE REBOUND FROM INSIDE THE COCK PIT ON SHOCKS THAT ALLOW IT

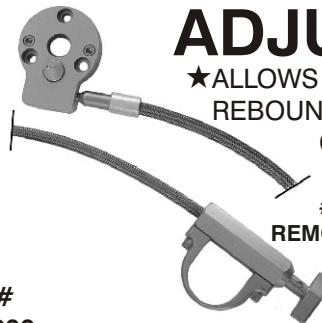

PART #  
PRO  
REMOTE-RADJ

★FOR USE ON BIG BODY ALUMINUM SMOOTH & THREADED SHOCKS: A836-11B, A843-8B, A846-11B, AC73738B, & AC93738B

WE NOW ALSO HAVE THE #PRO REMOTE-ADJ5 SMALL BODY REMOTE REBOUND ADJUSTER

Place your order at (479) 646-6988, Fax to (479) 646-5939, or visit [www.southwestspeed.com](http://www.southwestspeed.com)

# PRO SMALL BODY SHOCKS: STEEL & ALUM.

★SOLD IN SMOOTH STEEL & ALUMINUM & THREADED ALUMINUM; STEELS COME W/2 REMOVABLE BEARINGS; ALUMINUMS COME W/ 1 FIXED & 1 REMOVABLE

★5" = 10 3/8" COMPRESSED, 15 3/8" EXTENDED

★6" = 11 3/8" COMPRESSED, 17 3/8" EXTENDED

★7" = 12 3/8" COMPRESSED, 19 3/8" EXTENDED

★8" = 13 3/8" COMPRESSED, 21 3/8" EXTENDED

## ALUMINUM SMOOTH SMALL BODY

VALVE		RATE		TRA- VEL	PART #
OUT	IN	OUT	IN		
0.5	2	35 LB	125 LB	6"	PRO ASB62.05B
2	2	125 LB	125 LB	6"	PRO SBA62B
4	2	210 LB	125 LB	6"	PRO SBA624B
3	3	155 LB	155 LB	6"	PRO SBA63B
1	3	60 LB	155 LB	6"	PRO SBA631B
5	3	260 LB	155 LB	6"	PRO SBA635B
4	4	210 LB	210 LB	6"	PRO SBA64B
5	4	260 LB	210 LB	6"	PRO SBA645B
6	4	315 LB	210 LB	6"	PRO SBA646B
5	5	260 LB	260 LB	6"	PRO SBA65B
1	5	60 LB	260 LB	6"	PRO SBA651B
2	5	125 LB	260 LB	6"	PRO SBA652B
3	5	155 LB	260 LB	6"	PRO SBA653B
4	5	210 LB	260 LB	6"	PRO SBA654B
7	5	370 LB	260 LB	6"	PRO SBA657B
6	6	315 LB	315 LB	6"	PRO SBA66B
3	6	155 LB	315 LB	6"	PRO SBA663B
4	6	210 LB	315 LB	6"	PRO SBA664B
7	7	370 LB	370 LB	6"	PRO SBA67B
1	9	60 LB	600 LB	6"	PRO SBA691B
4	2	210 LB	125 LB	7"	PRO SBA724B
3	3	155 LB	155 LB	7"	PRO SBA73B
6	3	315 LB	155 LB	7"	PRO SBA736B
4	4	210 LB	210 LB	7"	PRO SBA74B
6	4	315 LB	210 LB	7"	PRO SBA746B
5	5	260 LB	260 LB	7"	PRO SBA75B
1	5	60 LB	260 LB	7"	PRO SBA751B
2	5	125 LB	260 LB	7"	PRO SBA752B
3	5	155 LB	260 LB	7"	PRO SBA753B
4	5	210 LB	260 LB	7"	PRO SBA754B
7	5	370 LB	260 LB	7"	PRO SBA757B
6	6	315 LB	315 LB	7"	PRO SBA76B
3	6	155 LB	315 LB	7"	PRO SBA763B
4	6	210 LB	315 LB	7"	PRO SBA764B
7	7	370 LB	370 LB	7"	PRO SBA77B
1	9	60 LB	600 LB	7"	PRO SBA791B
3	3	155 LB	155 LB	8"	PRO SBA83B
5	3	260 LB	155 LB	8"	PRO SBA835B
8	3	480 LB	155 LB	8"	PRO SBA838B
4	4	210 LB	210 LB	8"	PRO SBA84B
6	4	315 LB	210 LB	8"	PRO SBA846B
7	4	370 LB	210 LB	8"	PRO SBA847B
4.5	4.5	235 LB	235 LB	8"	PRO SBA84.5B
1	5	60 LB	260 LB	8"	PRO SBA851B
3	5	155 LB	260 LB	8"	PRO SBA853B
6	5	315 LB	260 LB	8"	PRO SBA856B
6	5	315 LB	260 LB	8"	PRO SBA856TB
6	6	315 LB	315 LB	8"	PRO SBA86B
7	7	370 LB	370 LB	8"	PRO SBA87B

FOR 1 7/8" I.D. SPRINGS, USE COILOVER KIT #180-0254

FOR 5" O.D. SPRINGS, USE COILOVER KIT #179-9754

## SMALL BODY BEARINGS

★1/2" BORE, 1/2" SHAFT

★STEEL & ALUMINUM  
ROD ENDS AVAILABLE

★FITS SMALL BODY  
STEEL, & SMALL  
BODY ALUMINUM



STEEL #  
PRO WB275  
ALUM #  
PRO B275

## STEEL SMOOTH SMALL BODY

VALVE		RATE		TRA- VEL	PART #
OUT	IN	OUT	IN		
1	1	60 LB	60 LB	5"	PRO SB51B
2	2	125 LB	125 LB	5"	PRO SB52B
3	3	155 LB	155 LB	5"	PRO SB53B
4	4	210 LB	210 LB	5"	PRO SB54B
2	2	125 LB	125 LB	6"	PRO SB62B
4	2	210 LB	125 LB	6"	PRO SB624B
3	3	155 LB	155 LB	6"	PRO SB63B
1	3	60 LB	155 LB	6"	PRO SB631B
4	4	210 LB	210 LB	6"	PRO SB64B

AVAILABLE W/O BEARINGS, JUST TAKE THE "B" OFF THE PART #

FOR 1 7/8" I.D. SPRINGS, USE COILOVER KIT #180-0254

FOR 5" O.D. SPRINGS, USE COILOVER KIT #179-9754

## ALUMINUM THREADED SMALL BODY

VALVE		RATE		TRA- VEL	PART #
OUT	IN	OUT	IN		
0.5	2	35 LB	125 LB	6"	PRO ASB62.05B
2	2	125 LB	125 LB	6"	PRO ASB62B
4	2	210 LB	125 LB	6"	PRO ASB624B
5	2	260 LB	125 LB	6"	PRO ASB625B
0.5	3	35 LB	155 LB	6"	PRO ASB63.05B
3	3	155 LB	155 LB	6"	PRO ASB63B
1	3	60 LB	155 LB	6"	PRO ASB631B
5	3	260 LB	155 LB	6"	PRO ASB635B
4	4	210 LB	210 LB	6"	PRO ASB64B
6	4	315 LB	210 LB	6"	PRO ASB646B
5	5	260 LB	260 LB	6"	PRO ASB65B
1	5	60 LB	260 LB	6"	PRO ASB651B
2	5	125 LB	260 LB	6"	PRO ASB652B
3	5	155 LB	260 LB	6"	PRO ASB653B
4	5	210 LB	260 LB	6"	PRO ASB654B
7	5	370 LB	260 LB	6"	PRO ASB657B
6	6	315 LB	315 LB	6"	PRO ASB66B
3	6	155 LB	315 LB	6"	PRO ASB663B
4	6	210 LB	315 LB	6"	PRO ASB664B
7	7	370 LB	370 LB	6"	PRO ASB67B
1	9	60 LB	600 LB	6"	PRO ASB691B
3	3	155 LB	155 LB	7"	PRO ASB73B
5	3	260 LB	155 LB	7"	PRO ASB735B
4	4	210 LB	210 LB	7"	PRO ASB74B
1	4	60 LB	210 LB	7"	PRO ASB741B
2	4	125 LB	210 LB	7"	PRO ASB742B
6	4	315 LB	210 LB	7"	PRO ASB746B
5	5	260 LB	260 LB	7"	PRO ASB75B
1	5	60 LB	260 LB	7"	PRO ASB751B
2	5	125 LB	260 LB	7"	PRO ASB752B
3	5	155 LB	260 LB	7"	PRO ASB753B
4	5	210 LB	260 LB	7"	PRO ASB754B
7	5	370 LB	260 LB	7"	PRO ASB757B
6	6	315 LB	315 LB	7"	PRO ASB76B
3	6	155 LB	315 LB	7"	PRO ASB763B
4	6	210 LB	315 LB	7"	PRO ASB764B
7	7	370 LB	370 LB	7"	PRO ASB77B
1	9	60 LB	600 LB	7"	PRO ASB791B
3	3	155 LB	155 LB	8"	PRO ASB83B
5	3	260 LB	155 LB	8"	PRO ASB835B
8	3	480 LB	155 LB	8"	PRO ASB838B
4	4	210 LB	210 LB	8"	PRO ASB84B
6	4	315 LB	210 LB	8"	PRO ASB846B
7	4	370 LB	210 LB	8"	PRO ASB847B
4.5	4.5	235 LB	235 LB	8"	PRO ASB84.5B
1	5	60 LB	260 LB	8"	PRO ASB851B
3	5	155 LB	260 LB	8"	PRO ASB853B
6	5	315 LB	260 LB	8"	PRO ASB856B
6	5	315 LB	260 LB	8"	PRO ASB856TB
6	6	315 LB	315 LB	8"	PRO ASB86B
7	7	370 LB	370 LB	8"	PRO ASB87B

FOR 1 7/8" I.D. SPRINGS, USE COILOVER KIT #180-0256

Place your order at (479) 646-6988, Fax to (479) 646-5939, or visit [www.southwestspeed.com](http://www.southwestspeed.com)



# PRO STREET STOCK SHOCKS

★SPECIALLY DESIGNED PRO STREET STOCK SHOCKS ARE MADE TO REPLACE THE STOCK OEM UNITS IN THE ORIGINAL MOUNTING LOCATIONS IN MOST INSTANCES

★THE "SS" SERIES SHOCKS HAVE EXTRA HEAVY DAMPENING DESIGNED FOR THE RIGORS OF STREET STOCK RACING

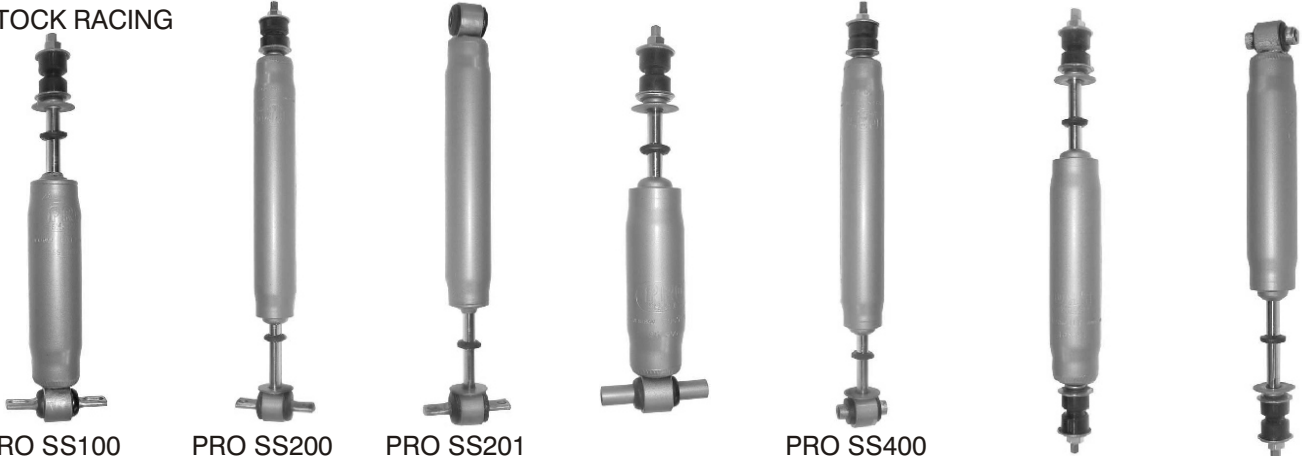

PRO SS100      PRO SS200      PRO SS201      PRO SS300      PRO SS400      PRO SS401      PRO SS402  
 PRO SS100A      PRO SS200A      PRO SS201A

APPLICATION	POSITION	COMPRESSED / EXTENDED	TRAVEL	PART #	ADJUSTABLE PART #
GM FULL SIZE & MID-SIZE: CHEVELLE, MONTE CARLO, CUTLASS, GRAND PRIX, GTO, TEMPEST, REGAL & SKYLARK 1970-81 CAMARO & FIREBIRD	FRONT	8.50" / 13.10"	4.6"	SS100	SS100A
	REAR	12.75" / 20.95"	8.2"	SS201	SS201A
	FRONT	8.50" / 13.10"	4.6"	SS100	SS100A
	REAR	12.85" / 21.69"	8.8"	SS200	SS200A
FORD FULL-SIZE & MID-SIZE: MERCURY & COUGAR	FRONT	8.50" / 13.10"	4.6"	SS100	SS100A
	REAR	12.85" / 21.69"	8.8"	SS400	SS400A
1974-78 MUSTANG II	FRONT	7.26" / 10.72"	3.5"	SS300	
	REAR	9.81" / 15.81"	6.0"	SS402	
	REAR	12.85" / 21.69"	8.8"	SS400	SS400A
MUSTANG 1971-80 PINTO (EXCEPT SW)	FRONT	7.26" / 10.72"	3.5"	SS300	
	REAR	8.77" / 14.17"	5.4"	SS401	
	REAR	12.85" / 21.69"	8.8"	SS400	SS400A

THE ADJUSTABLE SHOCKS ARE 3 SHOCKS IN 1: #1 ADJUSTMENT - EASY UP FOR WEIGHT TRANSFER  
 #2 ADJUSTMENT - 50/50 VALVING LIKE THE REGULAR SS  
 #3 ADJUSTMENT - TIEDOWN FOR SLOW WEIGHT TRANSFER FOR PAVEMENT OR TACKY TRACK

## MANY MORE UPPER A-ARMS ARE AVAILABLE ON PAGES 35-38

### GM METRIC UPPER A-ARMS

★STEEL SHAFTS

★ACCEPTS:

- \*#101-017 SMALL STOCK BOLT-IN BALL JOINTS OR
- \*#101-018 SMALL SCREW-IN BALL JOINTS

★BOLTS TO ALL STOCK GM METRIC (78-88 CHEVELLE, MONTE CARLO, EL CAMINO, MALIBU) MOUNTS

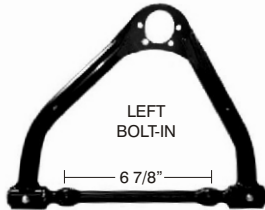
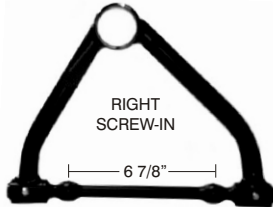

DESCRIPTION	LEFT	RIGHT
SCREW-IN METRIC, 8"	N/A	101-058
SCREW-IN METRIC, 8 1/2"	101-057	101-060
SCREW-IN METRIC, 9"	101-059	N/A
BOLT-IN METRIC, 8"	N/A	101-068
BOLT-IN METRIC, 8 1/2"	101-067	101-070
BOLT-IN METRIC, 9"	101-069	N/A

NOTE: FOR A CONSTANT STREAM OF NEW PRODUCTS & UP-TO-THE-SECOND PRICING, VISIT [WWW.SOUTHWESTSPEED.COM](http://WWW.SOUTHWESTSPEED.COM)

### CAMARO UPPER A-ARMS

★STEEL CROSS SHAFTS; FITS STOCK CAMARO A-ARM MOUNTS

★ACCEPTS: \*#101-016 LARGE RACING BOLT-IN OR \*#101-017 SMALL STOCK BOLT-IN BALL JOINTS

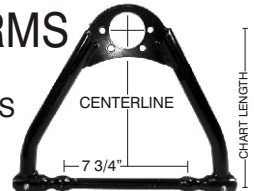

DESCRIPTION	BALL JOINTS	
	#101-016	#101-017
CAMARO TRIANGLE, 8"	106-080	106-060
CAMARO TRIANGLE, 8 1/4"	106-082	106-062
CAMARO TRIANGLE, 8 1/2"	106-085	106-065
CAMARO TRIANGLE, 8 3/4"	106-087	106-067
CAMARO TRIANGLE, 9"	106-090	106-070
CAMARO TRIANGLE, 9 1/4"	106-092	106-072
CAMARO TRIANGLE, 9 1/2"	106-095	106-075

### 82-92 CAMARO CASTER/CAMBER PLATE KIT

- ★MAKES CASTER & CAMBER ADJUSTMENTS A SNAP
- ★INCREASES STRUT TRAVEL
- ★ELIMINATES SUSPENSION BIND



PART #100-002

Place your order at (479) 646-6988, Fax to (479) 646-5939, or visit [www.southwestspeed.com](http://www.southwestspeed.com)

# BILSTEIN SHOCKS

★GAS CHARGED STEEL BODY

★LIGHTWEIGHT MONO-TUBE DESIGN

## Digressive Numbering System

# Compression dampening. (In) } (Down)

# Rebound dampening. (Out) } (Up)

Z 46mm Dia. (2 in.) Digressive Valving.

Stroke in inches. (Compression length subtracted from the extended length.)

Steel body grooved for snap rings

to seat coilover kit.

BILSTEIN OF AMERICA } BOA S 7 Z 50 50



**IMPORTANT:** Rebound and Compression are expressed in the industry standard, 4, 5, 6, etc. with a second digit to allow for a degree of dampening between whole numbers. For example: 50 means 5, 55 means 5 1/2.

## DIGRESSIVE VALVE - 46MM BIG BODY, 7"

COMPRESSED: 13.14"  
EXTENDED: 20"

OUT	IN	STROKE	PART #
80 LB	160 LB	7"	BOA S7Z-1030
80 LB	320 LB	7"	BOA S7Z-1060
80 LB	480 LB	7"	BOA S7Z-1080
80 LB	600 LB	7"	BOA S7Z-1090
80-210*	600 LB	7"	KNA 30-7914*
120 LB	120 LB	7"	BOA S7Z-2020
120 LB	210 LB	7"	BOA S7Z-2040
120 LB	320 LB	7"	BOA S7Z-2060
120 LB	480 LB	7"	BOA S7Z-2080
160 LB	160 LB	7"	BOA S7Z-3030
160 LB	210 LB	7"	BOA S7Z-3040
160 LB	260 LB	7"	BOA S7Z-3050
160 LB	320 LB	7"	BOA S7Z-3060
185 LB	160 LB	7"	BOA S7Z-3530
185 LB	235 LB	7"	BOA S7Z-3545
210 LB	80 LB	7"	BOA S7Z-4010
210 LB	120 LB	7"	BOA S7Z-4020
210 LB	210 LB	7"	BOA S7Z-4040
235 LB	290 LB	7"	BOA S7Z-4555
260 LB	160 LB	7"	BOA S7Z-5030
260 LB	260 LB	7"	BOA S7Z-5050
290 LB	290 LB	7"	BOA S7Z-5555
290 LB	380 LB	7"	BOA S7Z-5570
320 LB	80 LB	7"	BOA S7Z-6010
320 LB	120 LB	7"	BOA S7Z-6020
320 LB	210 LB	7"	BOA S7Z-6040
320 LB	320 LB	7"	BOA S7Z-6060
320 LB	350 LB	7"	BOA S7Z-6065
380 LB	160 LB	7"	BOA S7Z-7030
380 LB	235 LB	7"	BOA S7Z-7045
380 LB	320 LB	7"	BOA S7Z-7060
480 LB	210 LB	7"	BOA S7Z-8040
480 LB	320 LB	7"	BOA S7Z-8060
600 LB	80 LB	7"	BOA S7Z-9010

\*KNA 30-7914 IS A KONI AXLE DAMPNER SHOCK THAT IS REBOUND

ADJUSTABLE FROM 1 (80 LBS) TO 4 (210 LBS)

FOR 2 1/2" I.D. SPRINGS, USE COILOVER KIT #180-016 (5" SLEEVE)

OR #180-017 (7" SLEEVE). FOR 5" O.D. SPRINGS, USE COILOVER KIT

#179-966 (5" SLEEVE) OR #179-9672 (7" SLEEVE)

## COILOVER KIT SPACERS



★6061-T6 ALUMINUM; SLIPS OVER LOCK RING

SHOCK TYPE	2" KIT	3" KIT
BILSTEIN 46MM	180-052	180-054
BILSTEIN 36MM	180-059	N/A
CARRERA/PRO	180-056	180-058
KONI	180-052	180-054
MONROE/UNIVERSAL	180-056	180-058

NOTE: SOUTHWEST SPEED COILOVER KITS ARE ON PAGE 31.

# BILSTEIN SHOCKS DIGRESSIVE VALVE - 46MM BIG BODY, 9"

COMPRESSED: 14.94"  
EXTENDED: 23.44"

OUT	IN	STROKE	PART #
80 LB	600 LB	9"	BOA S9Z-1090
120 LB	120 LB	9"	BOA S9Z-2020
120 LB	210 LB	9"	BOA S9Z-2040
120 LB	320 LB	9"	BOA S9Z-2060
120 LB	380 LB	9"	BOA S9Z-2070
120 LB	480 LB	9"	BOA S9Z-2080
160 LB	80 LB	9"	BOA S9Z-3010
160 LB	160 LB	9"	BOA S9Z-3030
160 LB	210 LB	9"	BOA S9Z-3040
160 LB	260 LB	9"	BOA S9Z-3050
160 LB	320 LB	9"	BOA S9Z-3060
185 LB	160 LB	9"	BOA S9Z-3530
185 LB	185 LB	9"	BOA S9Z-3535
185 LB	235 LB	9"	BOA S9Z-3545
210 LB	80 LB	9"	BOA S9Z-4010
210 LB	120 LB	9"	BOA S9Z-4020
210 LB	210 LB	9"	BOA S9Z-4040
235 LB	235 LB	9"	BOA S9Z-4545
235 LB	290 LB	9"	BOA S9Z-4555
260 LB	160 LB	9"	BOA S9Z-5030
260 LB	260 LB	9"	BOA S9Z-5050
290 LB	290 LB	9"	BOA S9Z-5555
320 LB	80 LB	9"	BOA S9Z-6010
320 LB	120 LB	9"	BOA S9Z-6020
320 LB	210 LB	9"	BOA S9Z-6040
320 LB	320 LB	9"	BOA S9Z-6060
380 LB	160 LB	9"	BOA S9Z-7030
380 LB	235 LB	9"	BOA S9Z-7045
380 LB	320 LB	9"	BOA S9Z-7060
480 LB	210 LB	9"	BOA S9Z-8040

FOR 2 1/2" I.D. SPRINGS, USE COILOVER KIT #180-016 (5" SLEEVE)  
OR #180-017 (7" SLEEVE). FOR 5" O.D. SPRINGS, USE COILOVER KIT  
#179-966 (5" SLEEVE) OR #179-9672 (7" SLEEVE)

NOTE: DIGRESSIVE VALVING RATES ARE APPROXIMATE &  
CHECKED AT A SHAFT VELOCITY OF 20" PER SECOND

# SHOCKWEARS

★MADE FROM A DURABLE WATER REPELLENT

DENIER NYLON

★SOLD IN PAIRS

★PROTECTS THE SHOCK

WHILE LETTING AIR COOL THE SHOCK



DESCRIPTION	PART #
3.5" OD x 10" TALL, PAIR, BLACK	OWC 30-1245-BK
3.5" OD x 10" TALL, PAIR, BLUE	OWC 30-1245-BL
3.5" OD x 10" TALL, PAIR, RED	OWC 30-1245-RD
3.5" OD x 10" TALL, PAIR, YELLOW	OWC 30-1245-YL
3.5" OD x 10" TALL, PAIR, ORANGE	OWC 30-1245-OR
3.5" OD x 10" TALL, PAIR, PURPLE	OWC 30-1245-PP
3.5" OD x 12" TALL, PAIR, BLACK	OWC 30-1348-BK
3.5" OD x 12" TALL, PAIR, BLUE	OWC 30-1348-BL
3.5" OD x 12" TALL, PAIR, RED	OWC 30-1348-RD
3.5" OD x 12" TALL, PAIR, YELLOW	OWC 30-1348-YL
3.5" OD x 12" TALL, PAIR, ORANGE	OWC 30-1348-OR
3.5" OD x 12" TALL, PAIR, PURPLE	OWC 30-1348-PP
3.5" OD x 14" TALL, PAIR, BLACK	OWC 30-1165-BK
3.5" OD x 14" TALL, PAIR, BLUE	OWC 30-1165-BL
3.5" OD x 14" TALL, PAIR, RED	OWC 30-1165-RD
3.5" OD x 14" TALL, PAIR, YELLOW	OWC 30-1165-YL
3.5" OD x 14" TALL, PAIR, ORANGE	OWC 30-1165-OR
3.5" OD x 14" TALL, PAIR, PURPLE	OWC 30-1165-PP

Place your order at (479) 646-6988, Fax to (479) 646-5939, or visit [www.southwestspeed.com](http://www.southwestspeed.com)



# BILSTEIN SHOCKS

## Digressive Numbering System

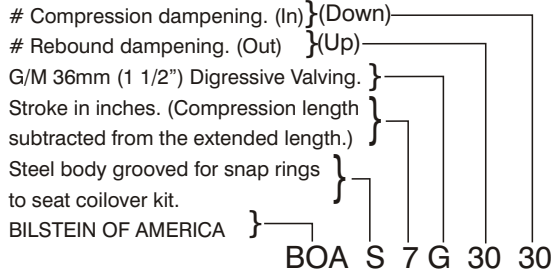

**IMPORTANT:** Rebound and Compression are expressed in the industry standard, 4, 5, 6, etc. with a second digit to allow for a degree of dampening between whole numbers. For example: 50 = 5 AND 55 = 5 1/2.

## DIGRESSIVE VALVE - 36MM

### SMALL BODY, 6"

★GAS CHARGED MONO-TUBE DESIGN

★MORE A-ARM CLEARANCE

★COMES WITH ONE

FIXED & ONE REMOVABLE BEARING

COMPRESSED: 11"  
EXTENDED: 17"



OUT	IN	STROKE	PART #
80 LB	160 LB	6"	BOA S6G-1030
80 LB	185 LB	6"	BOA S6G-1035
80 LB	260 LB	6"	BOA S6G-1050
80 LB	320 LB	6"	BOA S6G-1060
80 LB	480 LB	6"	BOA S6G-1080
80 LB	600 LB	6"	BOA S6G-1090
120 LB	120 LB	6"	BOA S6G-2020
120 LB	210 LB	6"	BOA S6G-2040
160 LB	80 LB	6"	BOA S6G-3010
160 LB	160 LB	6"	BOA S6G-3030
160 LB	210 LB	6"	BOA S6G-3040
160 LB	260 LB	6"	BOA S6G-3050
160 LB	320 LB	6"	BOA S6G-3060
185 LB	160 LB	6"	BOA S6G-3530
185 LB	185 LB	6"	BOA S6G-3535
185 LB	235 LB	6"	BOA S6G-3545
210 LB	80 LB	6"	BOA S6G-4010
210 LB	120 LB	6"	BOA S6G-4020
210 LB	210 LB	6"	BOA S6G-4040
235 LB	235 LB	6"	BOA S6G-4545
235 LB	290 LB	6"	BOA S6G-4555
260 LB	160 LB	6"	BOA S6G-5030
260 LB	260 LB	6"	BOA S6G-5050
290 LB	290 LB	6"	BOA S6G-5555
290 LB	380 LB	6"	BOA S6G-5570
320 LB	80 LB	6"	BOA S6G-6010
320 LB	120 LB	6"	BOA S6G-6020
320 LB	210 LB	6"	BOA S6G-6040
320 LB	320 LB	6"	BOA S6G-6060
320 LB	350 LB	6"	BOA S6G-6065
350 LB	350 LB	6"	BOA S6G-6565
380 LB	160 LB	6"	BOA S6G-7030
380 LB	235 LB	6"	BOA S6G-7045
380 LB	320 LB	6"	BOA S6G-7060
480 LB	210 LB	6"	BOA S6G-8040
480 LB	320 LB	6"	BOA S6G-8060
600 LB	80 LB	6"	BOA S6G-9010

FOR 1 7/8" I.D. SPRINGS, USE COILOVER KIT #180-034  
FOR 5" O.D. SPRINGS, USE COILOVER KIT #179-984

## SHOCK BEARINGS

★FITS ALL 6", 7", & 8"

36MM BILSTEIN SHOCKS

★1/2" MOUNTING HOLE

**PART #103-002**



# BILSTEIN SHOCKS

## DIGRESSIVE VALVE - 36MM

### SMALL BODY, 7"

COMPRESSED: 13"  
EXTENDED: 20"

★GAS CHARGED MONO-TUBE

★COMES W/ 1 FIXED & 1 REMOVABLE BEARING

OUT	IN	STROKE	PART #
80 LB	160 LB	7"	BOA S7G-1030
80 LB	320 LB	7"	BOA S7G-1060
80 LB	480 LB	7"	BOA S7G-1080
80 LB	600 LB	7"	BOA S7G-1090
120 LB	120 LB	7"	BOA S7G-2020
120 LB	210 LB	7"	BOA S7G-2040
160 LB	80 LB	7"	BOA S7G-3010
160 LB	160 LB	7"	BOA S7G-3030
160 LB	210 LB	7"	BOA S7G-3040
160 LB	260 LB	7"	BOA S7G-3050
160 LB	320 LB	7"	BOA S7G-3060
185 LB	160 LB	7"	BOA S7G-3530
185 LB	185 LB	7"	BOA S7G-3535
185 LB	235 LB	7"	BOA S7G-3545
210 LB	80 LB	7"	BOA S7G-4010
210 LB	120 LB	7"	BOA S7G-4020
210 LB	210 LB	7"	BOA S7G-4040
235 LB	235 LB	7"	BOA S7G-4545
235 LB	290 LB	7"	BOA S7G-4555
260 LB	160 LB	7"	BOA S7G-5030
260 LB	260 LB	7"	BOA S7G-5050
290 LB	290 LB	7"	BOA S7G-5555
290 LB	380 LB	7"	BOA S7G-5570
320 LB	80 LB	7"	BOA S7G-6010
320 LB	120 LB	7"	BOA S7G-6020
320 LB	185 LB	7"	BOA S7G-6035
320 LB	210 LB	7"	BOA S7G-6040
320 LB	320 LB	7"	BOA S7G-6060
320 LB	350 LB	7"	BOA S7G-6065
350 LB	350 LB	7"	BOA S7G-6565
380 LB	160 LB	7"	BOA S7G-7030
380 LB	185 LB	7"	BOA S7G-7035
380 LB	235 LB	7"	BOA S7G-7045
380 LB	320 LB	7"	BOA S7G-7060
480 LB	185 LB	7"	BOA S7G-8035
480 LB	210 LB	7"	BOA S7G-8040
480 LB	320 LB	7"	BOA S7G-8060
600 LB	80 LB	7"	BOA S7G-9010

## DIGRESSIVE VALVE - 36MM

### SMALL BODY, 8"

COMPRESSED: 14"  
EXTENDED: 22"

OUT	IN	STROKE	PART #
80 LB	600 LB	8"	BOA S8M-1090
120 LB	120 LB	8"	BOA S8M-2020
120 LB	210 LB	8"	BOA S8M-2040
160 LB	120 LB	8"	BOA S8M-3020
160 LB	160 LB	8"	BOA S8M-3030
160 LB	260 LB	8"	BOA S8M-3050
160 LB	320 LB	8"	BOA S8M-3060
185 LB	185 LB	8"	BOA S8M-3535
210 LB	80 LB	8"	BOA S8M-4010
210 LB	210 LB	8"	BOA S8M-4040
235 LB	235 LB	8"	BOA S8M-4545
260 LB	160 LB	8"	BOA S8M-5030
260 LB	260 LB	8"	BOA S8M-5050
290 LB	290 LB	8"	BOA S8M-5555
320 LB	120 LB	8"	BOA S8M-6020
320 LB	185 LB	8"	BOA S8M-6035
350 LB	350 LB	8"	BOA S8M-6565
380 LB	185 LB	8"	BOA S8M-7035
480 LB	185 LB	8"	BOA S8M-8035
600 LB	80 LB	8"	BOA S8M-9010

FOR 1 7/8" I.D. SPRINGS, USE COILOVER KIT #180-034  
FOR 5" O.D. SPRINGS, USE COILOVER KIT #179-984

Place your order at (479) 646-6988, Fax to (479) 646-5939, or visit [www.southwestspeed.com](http://www.southwestspeed.com)

# BILSTEIN TAKE APART SHOCKS

- ★STEEL & ALUMINUM, BIG BODY 46MM
- ★QUICK ASSEMBLY
- ★REPAIRABLE & REVALVABLE



DESCRIPTION	PART #
7" ALUM DIGRESSIVE VALVE	BOA B46-ADTA7
9" ALUM DIGRESSIVE VALVE	BOA B46-ADTA9
7" STEEL DIGRESSIVE VALVE	BOA B46-DTA7
8" STEEL DIGRESSIVE VALVE	BOA B46-DTA8
9" STEEL DIGRESSIVE VALVE	BOA B46-DTA9

FOR ALUMINUM TAKE APARTS WITH 2 1/2" I.D. SPRINGS, USE COILOVER KIT #180-018. FOR STEEL TAKE APARTS WITH 2 1/2" I.D. SPRINGS, USE COILOVER KIT #180-016 (5" SLEEVE) OR #180-017 (7" SLEEVE), WITH 5" O.D. SPRINGS, USE KIT #179-966 (5" SLEEVE) OR #179-9672 (7" SLEEVE)

# TAKE APART SHOCK PARTS, TOOLS, & HARDWARE

- ★PARTS TO REPAIR AND REVALVE TAKE APART SHOCKS
- ★FOR DIGRESSIVE & LINEAR VALVE SHOCKS

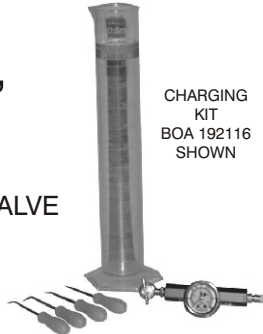

CHARGING  
KIT  
BOA 192116  
SHOWN

DESCRIPTION	PART #
VALVE KIT (2 PAIRS OF 8 LINEAR)	BOA 192114
VALVE KIT (2 PAIRS OF 8 DIGRESSIVE)	BOA 192115
CHARGE KIT (SHOWN ABOVE)	BOA 192116
ALUM END CAP ASSEMBLY, 46MM	BOA 192148
SHOCK CHARGING TOOL ONLY	BOA 193000
FILL CAP ASSEMBLY	BOA 193006
SHOCK ABSORBER OIL (1 QUART)	BOA 193030
SHOCK ABSORBER OIL (1 GAL)	BOA 193031
ALUM. THREAD END CAP ONLY, 46MM	BOA 193254
VALVE STEM ASSY, 46MM	BOA 193256
STEEL SHOCK BODY, 9", 46MM	BOA 193261
STEEL SHOCK BODY, 7", 46MM	BOA 193285
SQUARE SEALING RUBBER RING	BOA 193305
DISASSEMBLY TOOL	BOA 193343
CONCAVE WASHER, DIGRESSIVE	BOA 420968
SHOCK SHAFT, 14x245 MM, 9"	BOA 421251
SHOCK SHAFT, 14x201.5 MM, 7"	BOA 428381
LINEAR PISTON, 46MM	BOA 423282
DIGRESSIVE PISTON, 46MM	BOA 424698
SPHERICAL BEARING & SNAP RING	BOA 427601
DIVIDING PISTON ASSEMBLY, 46MM	BOA 454015
TEFLON PISTON BAND, 46MM	BOA 780046

# SHOCK VALVING MANUAL

- ★INSTRUCTS YOU ON HOW TO REBUILD YOUR TAKE-APART SHOCKS
  - ★STAIN FREE LAMINATED PAGES
- PART #BOA 194000**



NOTE: FOR A CONSTANT STREAM OF NEW PRODUCTS & UP-TO-THE-SECOND PRICING, VISIT [WWW.SOUTHWESTSPEED.COM](http://WWW.SOUTHWESTSPEED.COM)

# BILSTEIN SHOCK VALVE KITS

DESCRIPTION	PART #
VALVE STACK: 10 OUT, 90 IN	BOA 421090
VALVE STACK: 20 OUT, 20 IN	BOA 422020
VALVE STACK: 20 OUT, 40 IN	BOA 422040
VALVE STACK: 20 OUT, 60 IN	BOA 422060
VALVE STACK: 20 OUT, 80 IN	BOA 422080
VALVE STACK: 30 OUT, 30 IN	BOA 423030
VALVE STACK: 30 OUT, 40 IN	BOA 423040
VALVE STACK: 30 OUT, 50 IN	BOA 423050
VALVE STACK: 30 OUT, 60 IN	BOA 423060
VALVE STACK: 35 OUT, 30 IN	BOA 423530
VALVE STACK: 35 OUT, 45 IN	BOA 423545
VALVE STACK: 40 OUT, 10 IN	BOA 424010
VALVE STACK: 40 OUT, 20 IN	BOA 424020
VALVE STACK: 40 OUT, 40 IN	BOA 424040
VALVE STACK: 45 OUT, 55 IN	BOA 424555
VALVE STACK: 50 OUT, 30 IN	BOA 425030
VALVE STACK: 50 OUT, 50 IN	BOA 425050
VALVE STACK: 55 OUT, 55 IN	BOA 425555
VALVE STACK: 55 OUT, 70 IN	BOA 425570
VALVE STACK: 60 OUT, 10 IN	BOA 426010
VALVE STACK: 60 OUT, 20 IN	BOA 426020
VALVE STACK: 60 OUT, 40 IN	BOA 426040
VALVE STACK: 60 OUT, 60 IN	BOA 426060
VALVE STACK: 60 OUT, 65 IN	BOA 426065
VALVE STACK: 70 OUT, 30 IN	BOA 427030
VALVE STACK: 70 OUT, 45 IN	BOA 427045
VALVE STACK: 70 OUT, 60 IN	BOA 427060
VALVE STACK: 80 OUT, 40 IN	BOA 428040
VALVE STACK: 80 OUT, 60 IN	BOA 428060
VALVE STACK: 90 OUT, 10 IN	BOA 429010

# BILSTEIN SHOCKS LINEAR VALVE

- ★STEEL, GAS CHARGED, MONO-TUBE DESIGN

OUT	IN	STROKE	PART #
230 LB	78 LB	7"	BOA B46-0210A
208 LB	72 LB	7"	BOA B46-0210B
155 LB	68 LB	7"	BOA B46-0210C
220 LB	120 LB	7"	BOA B46-0210D
300 LB	100 LB	7"	BOA B46-0210H
180 LB	95 LB	7"	BOA B46-0210L
185 LB	820 LB	7"	BOA B46-0210LB
180 LB	120 LB	7"	BOA B46-0210R
200 LB	180 LB	7"	BOA B46-0210U
270 LB	90 LB	7"	BOA B46-0210ZE
350 LB	160 LB	8"	BOA B46-GNF2
380 LB	160 LB	8"	BOA B46-GNF3
390 LB	180 LB	8"	BOA B46-GNF4
230 LB	100 LB	8"	BOA B46-GNR2
275 LB	110 LB	8"	BOA B46-GNR3
345 LB	135 LB	8"	BOA B46-GNR4
230 LB	78 LB	9"	BOA B46-0207A
208 LB	72 LB	9"	BOA B46-0207B
230 LB	100 LB	9"	BOA B46-0207S
175 LB	72 LB	9"	BOA B46-0207ZK

FOR 2 1/2" I.D. SPRINGS, USE COILOVER KIT #180-016 (5" SLEEVE) OR #180-017 (7" SLEEVE). FOR 5" O.D. SPRINGS, USE COILOVER KIT #179-966 (5" SLEEVE) OR #179-9672 (7" SLEEVE)

LINEAR VALVING RATES ARE APPROXIMATE & CHECKED AT A SHAFT VELOCITY OF 5" PER SECOND



Place your order at (479) 646-6988, Fax to (479) 646-5939, or visit [www.southwestspeed.com](http://www.southwestspeed.com)



# BILSTEIN STREET STOCK SHOCKS & STRUTS

★GAS CHARGED MONO-TUBE DESIGN ★DESIGNED TO REPLACE OEM SHOCKS



BOA AK3050F  
BOA AK3060F  
BOA AK4040F  
BOA AK5555F  
BOA AK6565F  
BOA AK1043  
BOA AK1051  
BOA AK2072  
BOA AK1053  
BOA AK1195



BOA AK2020R  
BOA AK2040R  
BOA AK3030R  
BOA AK5030R  
BOA AK6010R  
BOA AK1044  
BOA AK1052



BOA AK1054



BOA AK1049  
BOA AK1199



BOA AK1050  
BOA AK1196



BOA AK1198

APPLICATION	POSITION	LENGTH		DAMPENING		MOUNTING TYPES	PART #
		EXTEND	COMPRESS	OUT	IN		
73-88 Chevelle, Monte Carlo, El Camino, Regal +	FRONT	13.48"	8.60"	131	206	T-Bar to Pin	BOA AK3050F
73-88 Chevelle, Monte Carlo, El Camino, Regal +	FRONT	13.48"	8.60"	110	233	T-Bar to Pin	BOA AK3060F
73-88 Chevelle, Monte Carlo, El Camino, Regal +	FRONT	13.48"	8.60"	197	154	T-Bar to Pin	BOA AK4040F
73-88 Chevelle, Monte Carlo, El Camino, Regal +	FRONT	13.48"	8.60"	245	190	T-Bar to Pin	BOA AK5555F
73-88 Chevelle, Monte Carlo, El Camino, Regal +	FRONT	13.48"	8.60"	325	220	T-Bar to Pin	BOA AK6565F
73-88 Chevelle, Monte Carlo, El Camino, Regal +	FRONT	13.48"	8.60"	358	219	T-Bar to Pin	BOA AK1043
73-88 Chevelle, Monte Carlo, El Camino, Regal +	FRONT	11.93"	7.95"	393	172	T-Bar to Pin	BOA AK1051
73-88 Chevelle, Monte Carlo, El Camino, Regal +	REAR	20.31"	13.11"	70	70	T-Bar to Cantilever	BOA AK2020R
73-88 Chevelle, Monte Carlo, El Camino, Regal +	REAR	20.31"	13.11"	70	140	T-Bar to Cantilever	BOA AK2040R
73-88 Chevelle, Monte Carlo, El Camino, Regal +	REAR	20.31"	13.11"	158	117	T-Bar to Cantilever	BOA AK3030R
73-88 Chevelle, Monte Carlo, El Camino, Regal +	REAR	20.31"	13.11"	300	120	T-Bar to Cantilever	BOA AK5030R
73-88 Chevelle, Monte Carlo, El Camino, Regal +	REAR	20.31"	13.11"	185	70	T-Bar to Cantilever	BOA AK6010R
73-88 Chevelle, Monte Carlo, El Camino, Regal +	REAR	20.31"	13.11"	254	141	T-Bar to Cantilever	BOA AK1044
73-88 Chevelle, Monte Carlo, El Camino, Regal +	REAR	18.62"	11.28"	324	112	T-Bar to Cantilever	BOA AK1052
70-76 Camaro, Firebird	FRONT	14.02"	8.92"	381	233	T-Bar to Pin	BOA AK2072
77-81 Camaro, Firebird	FRONT	14.11"	9.21"	565	164	T-Bar to Pin	BOA AK1053
70-81 Camaro, Firebird	REAR	20.39"	12.72"	165	67	T-Bar to Pin	BOA AK1054
70-81 Camaro, Firebird - Koni Adjustable Shock	REAR	20.39"	12.72"	ADJUSTABLE		T-Bar to Pin	KNA 8040-1018
82-92 Camaro, Firebird (Strut)	FRONT	19.98"	14.41"	196	125	Strut	BOA AK1049
82-92 Camaro, Firebird	REAR	18.90"	11.81"	213	118	Pin to Cantilever	BOA AK1050
77-79 T-Bird, 79-93 Full Size Ford	FRONT	13.86"	9.21"	577	359	T-Bar to Pin	BOA AK1195
77-79 T-Bird, 79-93 Full Size Ford	REAR	19.80"	12.34"	310	130	Cantilever to Pin	BOA AK1196
87-93 Mustang (Strut)	FRONT	21.28"	15.94"	224	122	Strut	BOA AK1199
87-93 Mustang	REAR	20.16"	12.64"	152	103	Pin to Eye	BOA AK1198
79-93 Mustang - Koni Adjustable Shock	REAR	22.75"	15.00"	ADJUSTABLE		Pin to Eye	KNA 8041-1026S

Note: Street stock shock & strut rates are approximate & checked at a shaft velocity of 10" per second

## TIE ROD END SHOCK MOUNTS

★MAY BE USED WITH #180-099 ADAPTER TO MOUNT BEARING END SHOCK



PART #  
180-090



PART #  
180-091



PART #180-092



PART #  
180-093



PART #  
180-095



PART #180-094



PART #  
180-096\*  
\*Accepts  
ES-150 tie rod

## SPANNER WRENCHES

★ADJUSTS COILOVER NUTS  
★PLATED STEEL CONSTRUCTION  
★3 POPULAR STYLES



DESCRIPTION	PART #
SPANNER, SMALL BODY, BORED NUT	051-302
SPANNER, BIG BODY, SLOT/TANGED NUT	051-304
SPANNER, BIG BODY, BORED NUT	051-306

NOTE: IT IS RECOMMENDED THAT SPRING PRESSURE BE RELIEVED WHEN ADJUSTING COILOVERS.

## TIE ROD SHOCK END ADAPTER

★ADAPTS 1/2" BEARING END SHOCKS TO TIE ROD MOUNTS



PART #  
#180-099

Place your order at (479) 646-6988, Fax to (479) 646-5939, or visit [www.southwestspeed.com](http://www.southwestspeed.com)

# CARRERA STREET STOCK SHOCKS



CAR 2058      CAR 2384JY  
CAR 2385JY  
CAR 2385/3JY      CAR 2585J  
CAR 2585/3J      CAR 2665  
CAR 2785      CAR 2853/7J  
CAR 2856J  
CAR 2858J      CAR 2848T      CAR 2975  
CAR 2985

## DESIGNED TO REPLACE OEM SHOCKS

APPLICATION	POS. F/R	DAMPENING OUT/IN	PART #
71-73 MUSTANG, COUGAR, 60-70 FAIRLANE, FALCON, 75-80 GRANADA, 69-77 MAVERICK, 66-71 TORINO, MONTEGO, 70-74 JAVELIN, ALL OTHER 71-83 AMC, 62-67 CHEVY II	FRONT	500 LB.	CAR 2058
GM FULL SIZE AND MID-SIZE, MALIBU, CHEVELLE, MONTE CARLO, CUTLASS, GRAND PRIX, GTO, TEMPEST, REGAL, SKYLARK, NOVA	REAR	220 LB.	CAR 2384JY
		265 LB.	CAR 2385JY
		265/175 LB.	CAR 2385/3JY
ALL 70-81 CAMARO AND FIREBIRDS	REAR	265 LB.	CAR 2585J
		265/175 LB.	CAR 2585/3J
ALL FORD PINTOS	REAR	265 LB.	CAR 2665
60-73 MUSTANG, COUGAR, 60-70 FAIRLANE, FALCON, 66-71 TORINO, MONTEGO, 71-83 AMC EXCEPT JAVELIN	REAR	265 LB.	CAR 2785
ALL FORD PINTOS	FRONT	380 LB.	CAR 2848T
GM FULL SIZE AND MID-SIZE 70-81 CAMARO, FIREBIRD, FORD FULL SIZE & MID-SIZE, MONTEGO, AND COUGAR	FRONT	175/380 LB	CAR 2853/7J
		320 LB.	CAR 2856J
		500 LB.	CAR 2858J
68-74 JAVELIN, 65-88 FULL SIZE FORD, 79-88 FAIRMONT, ZEPHYR, MUSTANG, CAPRI, 82-88 CAMARO, FIREBIRD, 67-69 CAMARO, FIREBIRD, 76-87 CHEVETTE, 55-57 CHEVY	REAR	265 LB.	CAR 2975
HOBBY STOCK	REAR	265 LB.	CAR 2985

Place your order at (479) 646-6988, Fax to (479) 646-5939, or visit [www.southwestspeed.com](http://www.southwestspeed.com)

# CARRERA COILOVER SHOCKS

- ★3100 SERIES
- ★CHROME PLATED, SMOOTH STEEL BODY
- ★HYPER CHARGED

DAMPENING RATE			
OUT	IN	STROKE	PART #
50 LB	500 LB	7"	CAR 3171/9
135 LB	320 LB	7"	CAR 3172/6
175 LB	175 LB	7"	CAR 3173
175 LB	265 LB	7"	CAR 3173/5
220 LB	220 LB	7"	CAR 3174
220 LB	320 LB	7"	CAR 3174/6
265 LB	265 LB	7"	CAR 3175
320 LB	320 LB	7"	CAR 3176
380 LB	380 LB	7"	CAR 3177
380 LB	265 LB	7"	CAR 3177/5
175 LB	ADJ*	7"	CAR 3698xx
175 LB	175 LB	9"	CAR 3193
220 LB	220 LB	9"	CAR 3194
265 LB	265 LB	9"	CAR 3195
265 LB	175 LB	9"	CAR 3195/3
320 LB	320 LB	9"	CAR 3196
350 LB	265 LB	9"	CAR 3196/5

FOR 2 1/2" I.D. SPRINGS, USE COILOVER KIT #180-020 (5" SLEEVE) OR #180-021 (7" SLEEVE). FOR 5" O.D. SPRINGS, USE COILOVER KIT #179-970 (5" SLEEVE) OR #179-971 (7" SLEEVE)



# CARRERA WELDED BEARING

- ★2100 SERIES
- ★WELDED 1/2" ROD END

DAMPENING RATE			
OUT	IN	STROKE	PART #
50 LB	500 LB	7"	CAR 2171/9
175 LB	265 LB	7"	CAR 2173/5
175 LB	320 LB	7"	CAR 2173/6
220 LB	220 LB	7"	CAR 2174
265 LB	265 LB	7"	CAR 2175
320 LB	320 LB	7"	CAR 2176
380 LB	380 LB	7"	CAR 2177
175 LB	175 LB	9"	CAR 2193
220 LB	220 LB	9"	CAR 2194
265 LB	265 LB	9"	CAR 2195
265 LB	175 LB	9"	CAR 2195/3
320 LB	320 LB	9"	CAR 2196

FOR 2 1/2" I.D. SPRINGS, USE COILOVER KIT #180-020 (5" SLEEVE) OR #180-021 (7" SLEEVE). FOR 5" O.D. SPRINGS, USE COILOVER KIT #179-970 (5" SLEEVE) OR #179-971 (7" SLEEVE)  
\*WB SHOCKS MUST BE GROOVED FOR COILOVER KIT SNAP RING

# SMALL BODIED COILOVER SHOCKS

- ★3200 SERIES
- ★CHROME PLATED
- ★HYPER CHARGED



DAMPENING RATE			
OUT	IN	STROKE	PART #
135 LB	ADJ*	4 1/2"	CAR 3252
175 LB	ADJ*	4 1/2"	CAR 3253
220 LB	ADJ*	4 1/2"	CAR 3254
250 LB	ADJ*	5 1/2"	CAR 3265
100 LB	ADJ*	6"	CAR 3361
100 LB	135 LB	6"	CAR 3361/2
135 LB	ADJ*	6"	CAR 3362
175 LB	ADJ*	6"	CAR 3363
220 LB	ADJ*	6"	CAR 3364
135 LB	ADJ*	7"	CAR 3372
175 LB	ADJ*	7"	CAR 3373
220 LB	ADJ*	7"	CAR 3374

FOR 1 7/8" I.D. SPRINGS, USE COILOVER KIT #180-019

\*ADJUSTABLE SHOCK VALVING  
POSITION #1: 45/55 #2: 50/50 #3: 55/45

# SHOCK PINS

- ★FITS ALL POPULAR MOUNTS
- ★REPLACES BOLT & BUSHING
- ★THREE POSITION
- ★ONE SIZE FITS ALL



STEEL	ALUMINUM
180-085	180-087

# ALUMINUM SHOCKS

- ★6100 SERIES THREADED BODY
- ★HYPER CHARGED

DAMPENING RATE			
OUT	IN	STROKE	PART #
175 LB	175 LB	7"	CAR 6173
175 LB	265 LB	7"	CAR 6173/5
220 LB	220 LB	7"	CAR 6174
265 LB	265 LB	7"	CAR 6175
265 LB	175 LB	7"	CAR 6175/3
320 LB	320 LB	7"	CAR 6176
380 LB	380 LB	7"	CAR 6177
380 LB	175 LB	7"	CAR 6177/3
175 LB	175 LB	9"	CAR 6193
175 LB	265 LB	9"	CAR 6193/5
220 LB	220 LB	9"	CAR 6194
242 LB	242 LB	9"	CAR 61945
265 LB	265 LB	9"	CAR 6195
265 LB	175 LB	9"	CAR 6195/3
320 LB	320 LB	9"	CAR 6196

FOR 2 1/2" I.D. SPRINGS, USE COILOVER KIT #180-022



# ALUMINUM MONO TUBE

- ★9100 SERIES THREADED BODY
- ★HYPER CHARGED GP



DAMPENING RATE			
OUT	IN	STROKE	PART #
175 LB	265 LB	7"	CAR 9173/5
220 LB	220 LB	7"	CAR 9174
265 LB	265 LB	7"	CAR 9175
265 LB	175 LB	7"	CAR 9175/3
265 LB	220 LB	7"	CAR 9175/4
175 LB	175 LB	9"	CAR 9193
175 LB	265 LB	9"	CAR 9193/5
220 LB	220 LB	9"	CAR 9194
265 LB	175 LB	9"	CAR 9195/3
265 LB	220 LB	9"	CAR 9195/4

FOR 2 1/2" I.D. SPRINGS, USE COILOVER KIT #180-023

Place your order at (479) 646-6988, Fax to (479) 646-5939, or visit [www.southwestspeed.com](http://www.southwestspeed.com)



# COILOVER KITS FOR 1 7/8" I.D., 2 1/2" I.D., & 5" O.D. SPRINGS

- ★KITS AVAILABLE TO PUT 3 DIFFERENT SIZE SPRINGS ON ALMOST ANY SHOCK
- ★CHECK THE CHART BELOW TO SEE WHICH KIT FITS YOUR APPLICATION
- ★ALL KITS INCLUDE ENOUGH PARTS TO COMPLETE THE INSTALLATION OF THE SPRING ON THE SHOCK, INCLUDING CONE, SLEEVE, ADJUSTING NUT, SNAP RING, & COTTER PIN; THE 5" KITS ALSO INCLUDE ADAPTERS FOR THE LARGER SPRINGS
- ★KITS FOR THREADED SHOCKS DON'T REQUIRE THE SLEEVE



   	FOR 1 7/8" I.D. SPRINGS		FOR 2 1/2" I.D. SPRINGS		FOR 5" O.D. SPRINGS	
	5" TALL KIT	7" TALL KIT	5" TALL KIT	7" TALL KIT	5" TALL KIT	7" TALL KIT
BILSTEIN 36MM SMALL BODY	180-034	-	-	-	179-984	-
BILSTEIN 46MM BIG BODY	-	-	180-016	180-017	179-966	179-9672
BILSTEIN 46MM, ALUM THREADED	-	-	180-018		-	-
PRO WB, WELDED BEARING*	-	-	180-030	180-031	179-980	179-9792
PRO TAKE APART	-	-	180-024	180-025	179-974	179-9752
PRO GAS	-	-	180-024	180-025	179-974	179-9752
PRO ALUM. SMOOTH BIG BODY	-	-	180-024	180-025	179-974	179-9752
PRO ALUM. THREADED BIG BODY	-	-	180-0255		-	-
PRO STEEL SMOOTH SMALL BODY	180-0254	-	-	-	179-9754	-
PRO ALUM. SMOOTH SMALL BODY	180-0254	-	-	-	179-9754	-
PRO ALUM. THREADED SMALL BODY	180-0256		-	-	-	-
KONI 30 SERIES	-	-	180-026	180-027	179-976	179-977
CARRERA 2100 SER., WELDED BRG.*	-	-	180-020	180-021	179-970	179-971
CARRERA 3100 SER., BIG BODY	-	-	180-020	180-021	179-970	179-971
CARRERA 3200 SER., SMALL BODY	180-019	-	-	-	-	-
CARRERA 6100 SER., THREADED, BB	-	-	180-022		-	-
CARRERA 9100 SER., THREADED, BB	-	-	180-023		-	-
MONROE	-	-	180-030	180-031	179-980	179-9792
MONROE WITH SNAP WIRE CONE	-	-	180-032	180-033	179-982	179-983
QA1 5900 SER. WELDED BEARING*	-	-	180-020	180-021	179-970	179-971
QA1 5500 SERIES, BIG BODY	-	-	180-020	180-021	179-970	179-971

\*THESE WELDED BEARING SHOCKS MUST BE GROOVED FOR COILOVER KIT SNAP RING, #790-198 GROOVING TOOL AVAILABLE

## INDIVIDUAL PARTS



TAPERED CONES	
FITS	PART #
BILSTEIN 36MM SMALL BODY	180-011
BILSTEIN 46MM BIG BODY & ALUM. THREADED	180-0102
PRO WB & MONROE	180-014
PRO GAS, TAKE APART, & ALUM. SMOOTH BIG BODY	180-012
KONI 30 SERIES	180-0151
CARRERA 2100, 3100, 6100, 9100, QA1 5500 & 5900	180-010
CARRERA 3200 SERIES	180-013
MONROE WITH SNAP WIRE CONE*	180-015
*SNAP WIRE ONLY FOR 180-015	179-950
ADJUSTING NUTS	
FITS	PART #
BILSTEIN 36MM SMALL BODY	180-036
BILSTEIN 46MM BIG BODY & ALUM. THREADED, PRO GAS, WB, TAKE APART, & ALUM. SMOOTH BIG BODY, KONI 30, CARRERA 2100 & 3100, MONROE, & QA1 5500 & 5900	180-040
CARRERA 3200 SERIES	180-039
CARRERA 6100 SERIES	180-043

SHOCK GROOVING TOOL	
DESCRIPTION	PART #
PUTS A GROOVE FOR A SNAP RING IN ANY TWIN-TUBE SHOCK NOT EXCEEDING 2 1/8"	790-198
5" TALL THREADED SLEEVES	
FITS	PART #
BILSTEIN 36MM SMALL BODY (ONLY 4" TALL)	180-000
BILSTEIN 46MM BIG BODY & KONI 30 SERIES	180-002
PRO WB & MONROE	180-008
PRO GAS, TAKE APART, & ALUM. SMOOTH BIG BODY	180-006
CARRERA 2100 & 3100, & QA1 5500 & 5900	180-005
CARRERA 3200 SERIES	180-005
7" TALL THREADED SLEEVES	
FITS	PART #
BILSTEIN 46MM BIG BODY & KONI 30 SERIES	180-003
PRO WB & MONROE	180-009
PRO GAS, TAKE APART, & ALUM. SMOOTH BIG BODY	180-007
CARRERA 2100 & 3100, & QA1 5500 & 5900	180-007
SNAP RINGS	
FITS	PART #
BILSTEIN 36MM	180-048
BILSTEIN 46MM BIG BODY & KONI 30 SERIES	180-051
PRO GAS, WB, TAKE APART, & ALUM. SMOOTH BIG BODY, CARRERA 2100 & 3100, MONROE, & QA1 5500 & 5900	180-050
CARRERA 3200 SERIES	180-049

Place your order at (479) 646-6988, Fax to (479) 646-5939, or visit [www.southwestspeed.com](http://www.southwestspeed.com)

# ROLLER BEARING COILOVER ELIMINATORS

**PART #050-900 (SHORT)**  
**COMPRESSION 15 1/2"**  
**EXTENSION 21 3/4"**

**PART #050-901 (LONG)**  
**COMPRESSION 16"**  
**EXTENSION 24 1/2"**

- ★ LIGHTWEIGHT STEEL
- ★ DUAL SEAL DESIGN WITH INTERNAL STOP
- ★ #050-900 ACCEPTS 7" TO 13" SPRINGS
- ★ #050-901 ACCEPTS 7" TO 16" SPRINGS

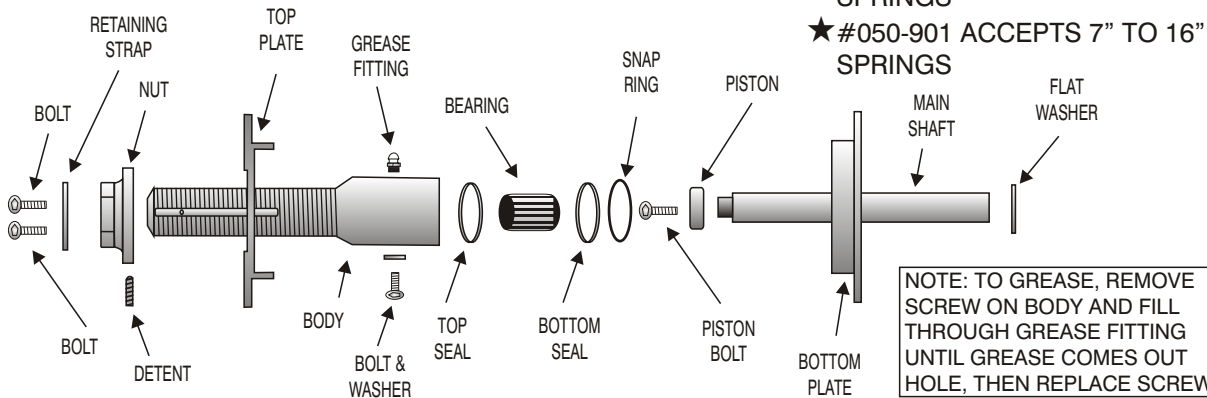

DESCRIPTION	PART #
COILOVER ELIMINATOR WITH BEARING (SHORT)	050-900
COILOVER ELIMINATOR WITH BEARING (LONG)	050-901
COILOVER ELIMINATOR COMPLETE OVERHAUL KIT	050-925
COILOVER ELIMINATOR PISTON BOLT	050-906
COILOVER ELIMINATOR PISTON	050-909
COILOVER ELIMINATOR SNAP RING	050-911
COILOVER ELIMINATOR TOP SEAL ONLY	051-012
COILOVER ELIMINATOR BOTTOM SEAL ONLY	050-932
COILOVER ELIMINATOR BEARING ONLY	050-933
COILOVER ELIMINATOR BOTTOM PLATE	051-008
COILOVER ELIMINATOR TOP PLATE	050-916
COILOVER ELIMINATOR TOP PLATE RETAINING STRAP	050-917
COILOVER ELIMINATOR RETAINING STRAP BOLTS	980-305
COILOVER ELIMINATOR SHAFT (FOR LONG ELIMINATOR ONLY)	050-907

NOTE: #050-925 COMPLETE OVERHAUL KIT CONTAINS 1 PISTON BOLT, 1 PISTON, 1 SNAP RING, 1 TOP SEAL, 1 BOTTOM SEAL, & 1 BEARING

### MAINTENANCE INSTRUCTIONS

THIS UNIT HAS SOME CLOSE TOLERANCE PARTS AND NEEDS TO BE DISASSEMBLED, CLEANED THROUGHOUT, INSPECTED, AND REASSEMBLED EVERY 4 TO 6 RACE NIGHTS (DEPENDING ON CONDITIONS). ASSEMBLE WITH ANTI-SEIZE ON THE PISTON AND LIGHT OIL ON ROD. REMOVE BOLT AND WASHER FROM MAIN BODY AND FILL WITH GREASE USING GREASE FITTING UNTIL GREASE COMES OUT BOLT HOLE. REPLACE BOLT AND WASHER AND REINSTALL.

## SHOCK MOUNTS COMPLETE WITH BOLT, NUT, & BUSHING

TRIANGLE WIDE	LONG ROLL CAGE MOUNT LEFT	LONG ROLL CAGE MOUNT RIGHT	SHORT CAGE MOUNT	LONG CAGE MOUNT	TRUSS MOUNT
<b>PART # 180-060</b>	<b>PART # 180-061</b>	<b>PART # 180-062</b>	<b>PART # 180-064</b>	<b>PART # 180-065</b>	<b>PART # 180-075</b>
LOWER A-ARM	TRIANGLE NARROW	1 1/2" ROUND CLAMP-ON MOUNTS VERTICAL	1 1/2" ROUND CLAMP-ON MOUNTS HORIZONTAL	2" SQUARE CLAMP-ON MOUNT, VERTICAL	
<b>PART #180-066</b>	<b>PART #180-068</b>	<b>PART #180-080</b>	<b>PART #180-082</b>	<b>PART #180-084</b>	

Place your order at (479) 646-6988, Fax to (479) 646-5939, or visit [www.southwestspeed.com](http://www.southwestspeed.com)

# COILOVER ELIMINATORS WITH SEAL

- ★LIGHTWEIGHT STEEL CONSTRUCTION
- ★DETENT ACME NUT FOR QUICK ADJUSTMENT; CAN BE ADJUSTED BY WRENCH OR BY HAND, WHEN CAR IS JACKED UP
- ★SLOTTED SPRING PLATE FOR EASY SPRING CHANGES
- ★INTERNAL STOP SO UNIT CAN'T SEPARATE WHEN CAR IS JACKED UP
- ★MAIN SHAFT SEAL TO KEEP DIRT OUT
- ★SPACERS INCLUDED TO LENGTHEN UNIT
- ★ACCEPTS 7" TO 16" SPRINGS

**MAINTENANCE INSTRUCTIONS**

This unit has some close tolerance parts and needs to be disassembled, cleaned throughout, inspected, and reassembled every 4 to 6 race nights (depending on conditions).

Assemble with anti-seize on the piston and light oil on rod, and put a small amount of oil in bore before reassembly.

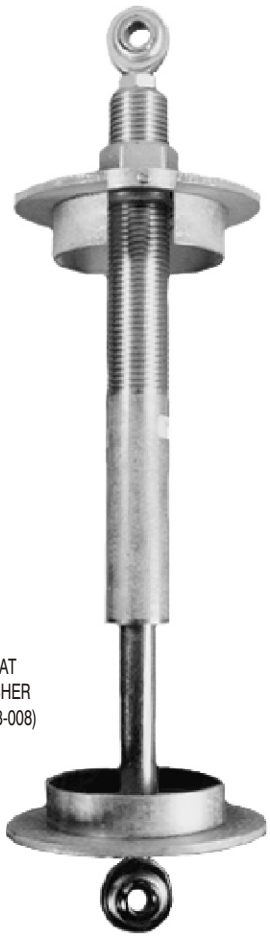

COMPRESSION 14" - 15 1/2"  
EXTENSION 21" - 22 1/2"

## COMPLETE ASSEMBLY PART NO. 051-006 OVERHAUL KIT PART NO. 051-025

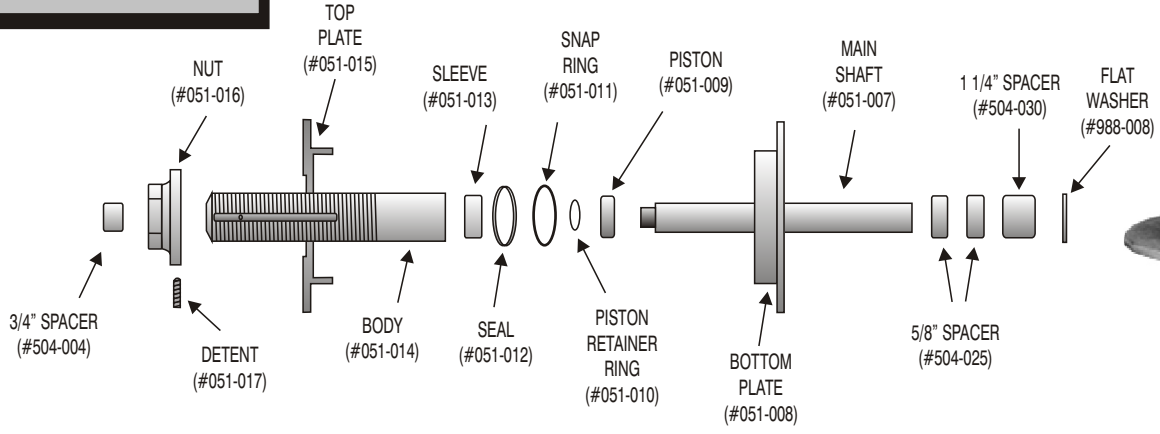

# COILOVER ELIMINATORS WITHOUT SEAL

- ★LIGHTWEIGHT STEEL
- ★NON BINDING DESIGN
- ★ACCEPTS 7" TO 16" SPRINGS
- ★LOW MAINTENANCE
- ★QUICK DISASSEMBLY



DESCRIPTION	PART #
COMPLETE ASSEMBLY	051-001
3" SPACER	050-994
MAIN SHAFT	050-995
TOP PLATE	050-996
BOTTOM PLATE	050-998

FILL MAIN BODY WITH GREASE USING THE GREASE INSERT AND PERIODICALLY CHECK THE SHAFT FOR WEAR.

# COIL SPRING RUBBERS

- ★MEASUREMENTS FOR THE SPACERS ARE TAKEN BETWEEN THE COILS
- ★HELPS FINE TUNE CHASSIS
- ★QUICK SPRING RATE CHANGE
- ★EASY IN AND OUT DESIGN
- ★FITS CONVENTIONAL 5" & 5 1/2" DIAMETER SPRINGS



DESCRIPTION	PART #
COIL SPRING RUBBER, 1/2"	050-808
COIL SPRING RUBBER, 3/4"	050-812
COIL SPRING RUBBER, 1"	050-816
COIL SPRING RUBBER, 1 1/2"	050-820
COIL SPRING RUBBER, 2"	050-822
COIL SPRING RUBBER, 2 1/2"	050-824

Place your order at (479) 646-6988, Fax to (479) 646-5939, or visit [www.southwestspeed.com](http://www.southwestspeed.com)



# UPPER A-ARM SHAFTS

## RACING A-ARM SHAFTS

- ★EXCLUSIVE SLOTTED SHAFT DESIGN PROVIDES 6" & 6 1/2" BOLT CENTERS
- ★1/4" OFFSET ALLOWS FOR SLIGHT ADJUSTMENT BY ROTATING THE SHAFT 180°
- ★STEEL OR ALUMINUM AVAILABLE



DESCRIPTION	PART #
156 HY-TUFF STEEL SHAFT KIT	101-037
7075-T6 ALUMINUM SHAFT KIT	101-038
STEEL SHAFT ONLY	101-040
ALUMINUM SHAFT ONLY	101-041
HONED WELD BUSHING ONLY (2 REQ.)	101-043
SNAP RING (2 REQ.)	101-044
GREASE FITTING, STRAIGHT (2 REQ.)	101-045

## STOCK A-ARM SHAFTS

- ★STEEL CROSS SHAFTS FIT STOCK CAMARO, CHEVELLE, & METRIC A-ARM MOUNTS
- ★BOLT CENTERS: 67-69 CAMARO=6 1/2", 70-81 CAMARO=7 3/4", 64-72 CHEVELLE=6 1/2", 78-88 METRIC=6 7/8"
- ★SOLD AS A COMPLETE SETS



DESCRIPTION	PART #
STOCK 70-81 CAMARO STEEL SHAFT KIT	101-035
STOCK 64-72 A-BODY/67-69 CAMARO KIT	101-036
STOCK 78-88 METRIC STEEL SHAFT KIT	101-039

## UPPER A-ARM MOUNTS

- ★6" BOLT CENTERS

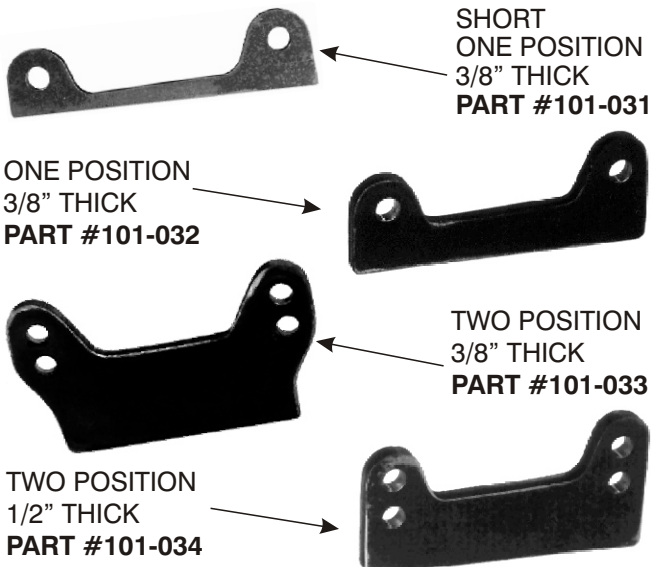

# UPPER A-ARM PLATES

- ★3/16" THICK
- ★FOR STOCK & RACING BALL JOINTS
- ★RACING PLATE COMES IN TRIANGLE & OFFSET



PLATE TO FIT	PART #
STOCK BALL JOINT #101-017, OFFSET	101-046
RACING JOINT #101-016 & #101-020, TRI	101-047
RACING JOINT #101-016 & #101-020, OFF	101-048

## UPPER A-ARM MOUNTS

- ★AVAILABLE WITH 1/2" & 5/8" BORE, 1/8" & 3/16" THICK, IN 2 DIFFERENT CONFIGURATIONS, 1 POSITION & 2 POSITION



DESCRIPTION	PART #
1 POSITION, 1/2" BORE, 1/8" THICK	101-0282
1 POSITION, 1/2" BORE, 3/16" THICK	101-0283
1 POSITION, 5/8" BORE, 1/8" THICK	101-0284
1 POSITION, 5/8" BORE, 3/16" THICK	101-0285
2 POSITION, 1/2" BORE, 3/16" THICK	101-0288
2 POSITION, 1/2" BORE, 3/16" THK, TALL	101-0289
2 POSITION, 5/8" BORE, 3/16" THICK	101-029
2 POSITION, 5/8" BORE, 3/16" THK, TALL	101-030
TEARDROP, 1 POS., 1/2" BORE, 1/8" THK	101-0272
TEARDROP, 1 POS., 1/2" BORE, 3/16" THK	101-0273
TEARDROP, 1 POS., 5/8" BORE, 1/8" THK	101-0274
TEARDROP, 1 POS., 5/8" BORE, 3/16" THK	101-0275

## SLOTTED UPPER A-ARM MOUNT & ADJUSTER

- ★ALLOWS FOR PRECISE ADJUSTMENT
- ★WELD #101-027 TO CHASSIS
- ★SOLD EACH



NOTE: REQUIRES TWO OF EACH PIECE FOR EACH UPPER A-ARM.

COMPLETE OEM UPPER A-ARM BOLT KITS AVAILABLE; SEE PAGE 250 FOR DETAILS.

Place your order at (479) 646-6988, Fax to (479) 646-5939, or visit [www.southwestspeed.com](http://www.southwestspeed.com)

# TRIANGLE UPPER A-ARMS - SCREW-IN BALL JOINT

- ★EXCLUSIVE SLOTTED SHAFTS FOR 6" AND 6 1/2" CENTERS
- ★WORKS WITH SCREW-IN BALL JOINT
- ★EXCLUSIVE 1/4" OFFSET SHAFTS
- ★USES BALL JOINT #101-018 OR #100-918

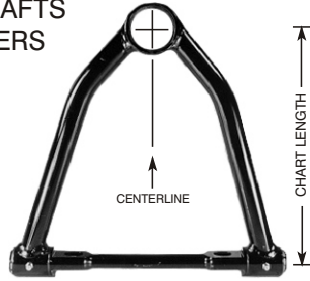

# OFFSET UPPER A-ARMS - SCREW-IN BALL JOINT

- ★EXCLUSIVE SLOTTED SHAFTS FOR 6" AND 6 1/2" CENTERS
- ★SCREW-IN BALL JOINT
- ★EXCLUSIVE 1/4" OFFSET SHAFTS
- ★USES BALL JOINT #101-018 OR #100-918

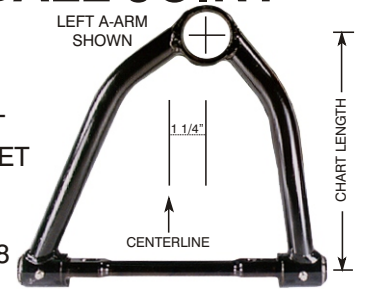

NOTE: ALL LENGTHS ARE CENTER OF SHAFT TO CENTER OF BALL JOINT. ROTATING A-ARM SHAFT 180 DEGREES INCREASES LENGTH 1/4". OFFSET A-ARMS LISTED LEFT & RIGHT WITH SHORT TUBE TO FRONT.

LENGTH	STEEL SHAFT	ALUMINUM SHAFT
7 1/4"	100-072	100-172
7 1/2"	100-075	100-175
7 3/4"	100-077	100-177
8"	100-080	100-180
8 1/4"	100-082	100-182
8 1/2"	100-085	100-185
8 3/4"	100-087	100-187
9"	100-090	100-190
9 1/4"	100-092	100-192
9 1/2"	100-095	100-195
9 3/4"	100-097	100-197
10"	100-100	100-200
10 1/4"	100-102	100-202
10 1/2"	100-105	100-205
10 3/4"	100-107	100-207
11"	100-110	100-210

LENGTH	STEEL SHAFT		ALUM. SHAFT	
	RIGHT	LEFT	RIGHT	LEFT
8 1/2"	100-285	100-385	100-485	100-585
8 3/4"	100-287	100-387	100-487	100-587
9"	100-290	100-390	100-490	100-590
9 1/4"	100-292	100-392	100-492	100-592
9 1/2"	100-295	100-395	100-495	100-595
9 3/4"	100-297	100-397	100-497	100-597
10"	100-300	100-400	100-500	100-600

## UPPER A-ARM SHIMS

- ★LIGHTWEIGHT ALUM.
- ★FITS 6" BOLT CENTERS
- ★WILL NOT FALL OUT WHILE SETTING FRONT END



DESCRIPTION	PART #
A-ARM SHIM, 1/16" THICK	100-010
A-ARM SHIM, 1/8" THICK	100-012
A-ARM SHIM, 1/4" THICK	100-014
A-ARM SHIM, 3/8" THICK	100-016
A-ARM SHIM, 1/2" THICK	100-018
A-ARM SHIM, 3/4" THICK	100-022
A-ARM SHIM, 1" THICK	100-024

## ADJUSTABLE MODIFIED A-ARMS

- ★FITS SEVERAL POPULAR MODIFIED CHASSIS
- ★ALLOWS FOR EASY ADJUSTMENT WHILE MOUNTED IN PLACE
- ★PART #101-6222 WITH THE FRAME MOUNTS AS SHOWN
- ★PART #101-6149 WITHOUT THE FRAME MOUNTS

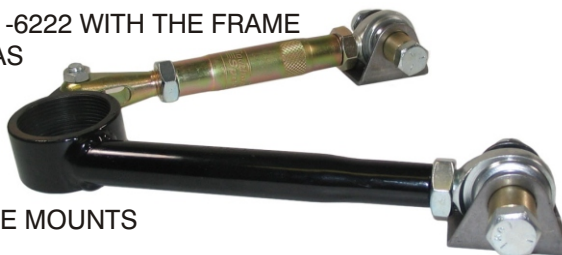

## PREMIER A-ARMS

- ★REPLACEABLE COMPONENTS
- ★ADJUSTABLE & LIGHTWEIGHT



SUPPLIED WITH 1 BALL JOINT HOLDER, 1 - 5" & 1 - 6" STEEL TUBE, 2 SHORT & 2 TALL BRACKETS, 1 CLEVIS, 2 LEFT & 2 RIGHT 5/8" ROD ENDS, 2 LEFT & 2 RIGHT 5/8" JAM NUTS, 4 ROD END SPACERS, 2 - 5/8" NUTS & BOLTS, AND 1 - 3/8" NUT & BOLT

DESCRIPTION	PART #
TRIANGLE A-ARM, COMPLETE	101-619
LEFT A-ARM, COMPLETE	101-620
RIGHT A-ARM, COMPLETE	101-621
TRIANGLE BALL JOINT HOLDER	100-985
LEFT BALL JOINT HOLDER	100-990
RIGHT BALL JOINT HOLDER	100-991
5/8" - 18R CLEVIS	102-980
ROD END SPACERS, STEEL (4 REQ.)	504-110
SHORT BRACKET (2 REQ.) 1 1/2", 2 3/8"	101-029
TALL BRACKET (2 REQ.) 1 3/4", 2 5/8"	101-030
5/8" - 18R JAM NUT (2 REQ.)	102-940
5/8" - 18L JAM NUT (2 REQ.)	102-950
5/8" - 18L ROD END (2 REQ.)	103-020
5" STEEL SWEDGED TUBE	501-005
6" STEEL SWEDGED TUBE	501-006
3/8" - 1 1/4" HEX HEAD BOLT, FINE	986-212
3/8" STOVER LOCK NUT, FINE THREAD	987-956
5/8" STOVER LOCK NUT, COARSE (2 REQ.)	987-940
5/8" - 2 1/2" HEX BOLT, COARSE (2 REQ.)	990-125

Place your order at (479) 646-6988, Fax to (479) 646-5939, or visit [www.southwestspeed.com](http://www.southwestspeed.com)

# BALL JOINT HOLDERS FOR PREMIER TYPE A-ARMS COMPARE YOUR HOLDER WITH THE DRAWINGS BELOW

\*NOTE: USE THE DRAWINGS BELOW TO DETERMINE THE BALL JOINT HOLDER THAT FITS YOUR CHASSIS. USE THE TOP VIEW TO DETERMINE THE SPACING BETWEEN THE STUD AND THE CLEVIS BRACKET AND NOTE THE STYLE OF THE CLEVIS BRACKET THAT MATCHES YOUR HOLDER. USE THE HORIZONTAL VIEW TO DETERMINE THE ANGLE (IF ANY) OF THE STUD AND THE CLEVIS BRACKET IN RELATIONSHIP WITH THE BALL JOINT HOLDER ON YOUR CHASSIS.

## TRIANGLE BALL JOINT HOLDERS FORGED TRIANGLE

- ★NEW, ALL 1 PIECE FORGED CONSTRUCTION

- ★NO WELDS
- ★USED IN #101-619 PREMIER UPPER A-ARMS
- ★SAME HOLDER USED FOR THE LEFT & THE RIGHT
- ★STUD & BRACKET HAVE NO ANGLE

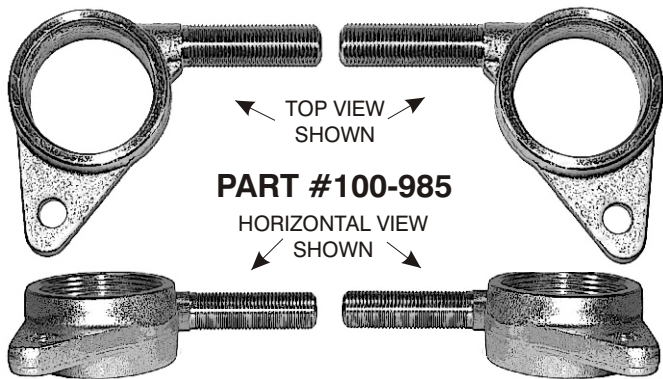

## ECONOMY TRIANGLE

- ★SAME HOLDER USED FOR THE LEFT & THE RIGHT
- ★STUD & BRACKET HAVE NO ANGLE
- ★FEATURES A LITTLE WIDER SPREAD BETWEEN STUD & BRACKET THAN THE #100-985, AS WELL AS THE BRACKET ITSELF BEING WIDER

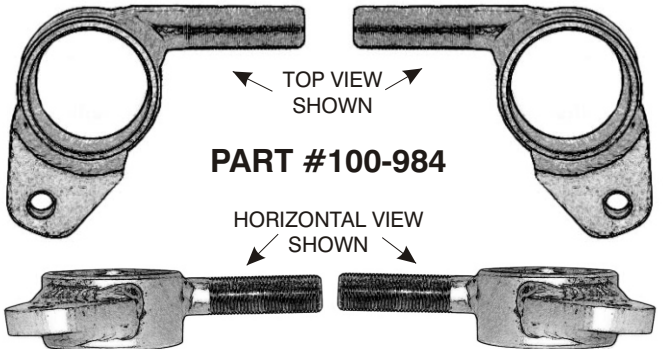

## CLEVIS

- ★5/8" -18 RIGHT HAND THREAD
- ★3/8" BORE, 3/8" SLOT



## SIDE-SPECIFIC BALL JOINT HOLDERS WIDE SPREAD

- ★BECAUSE OF THE ANGLES OF THE STUD & BRACKET, THERE IS ONE HOLDER FOR THE LEFT SIDE & ONE FOR THE RIGHT SIDE
- ★LEFT BALL JOINT HOLDER STUD & BRACKET ARE ANGLED DOWN
- ★RIGHT BALL JOINT HOLDER STUD IS ANGLED DOWN & BRACKET IS FLAT

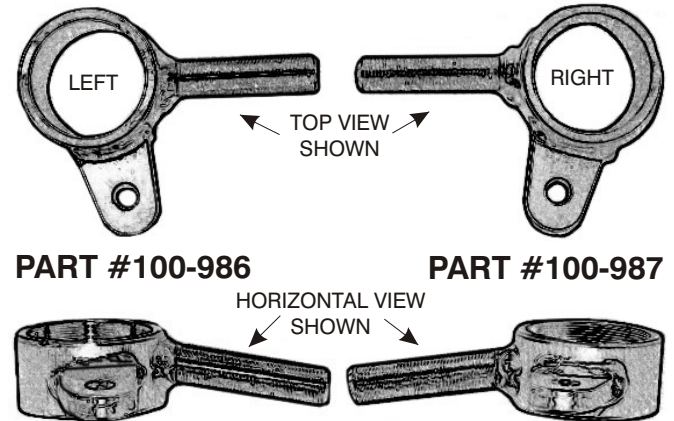

## NARROW SPREAD

- ★BECAUSE OF THE ANGLES OF THE STUD & BRACKET, THERE IS ONE HOLDER FOR THE LEFT SIDE & ONE FOR THE RIGHT SIDE
- ★USED IN #101-620 & #101-621 PREMIER UPPER A-ARMS
- ★LEFT HOLDER STUD & BRACKET ANGLED DOWN
- ★RIGHT HOLDER STUD SLIGHTLY ANGLED DOWN, WITH BRACKET STRAIGHT

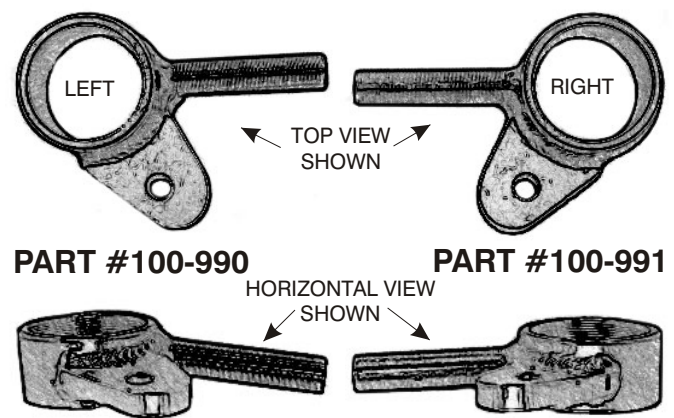

Place your order at (479) 646-6988, Fax to (479) 646-5939, or visit [www.southwestspeed.com](http://www.southwestspeed.com)



# TRIANGLE UPPER A-ARMS - BOLT-IN BALL JOINT

- ★EXCLUSIVE SLOTTED SHAFTS FOR 6" AND 6 1/2" CENTERS
- ★ALUMINUM OR STEEL SHAFT
- ★3/16" BALL JOINT PLATE
- ★EXCLUSIVE 1/4" OFFSET SHAFTS
- ★LIGHTWEIGHT DESIGN
- ★USES #101-016 OR #101-020 BALL JOINT

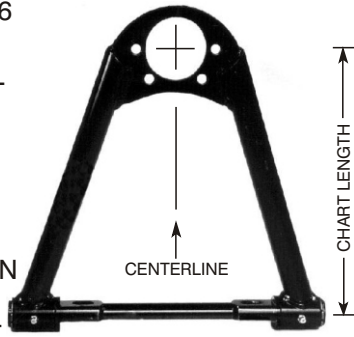

# OFFSET UPPER A-ARMS - BOLT-IN BALL JOINT

- ★EXCLUSIVE SLOTTED SHAFTS FOR 6" AND 6 1/2" CENTERS
- ★ALUMINUM OR STEEL SHAFT
- ★3/16" BALL JOINT PLATE
- ★EXCLUSIVE 1/4" OFFSET SHAFTS
- ★LIGHTWEIGHT DESIGN
- ★USES #101-016 OR #101-020 BALL JOINT

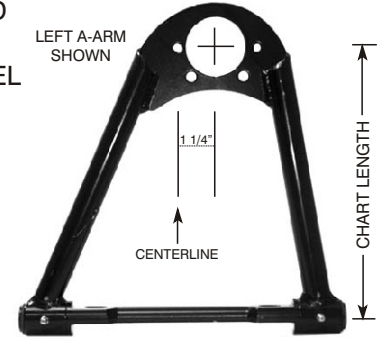

NOTE: ALL LENGTHS ARE CENTER OF SHAFT TO CENTER OF BALL JOINT. ROTATING A-ARM SHAFT 180 DEGREES INCREASES LENGTH 1/4". OFFSET A-ARMS LISTED LEFT & RIGHT WITH SHORT TUBE TO FRONT.

LENGTH	STEEL SHAFT	ALUMINUM SHAFT
7 1/4"	101-072	101-172
7 1/2"	101-075	101-175
7 3/4"	101-077	101-177
8"	101-080	101-180
8 1/4"	101-082	101-182
8 1/2"	101-085	101-185
8 3/4"	101-087	101-187
9"	101-090	101-190
9 1/4"	101-092	101-192
9 1/2"	101-095	101-195
9 3/4"	101-097	101-197
10"	101-100	101-200
10 1/4"	101-102	101-202
10 1/2"	101-105	101-205
10 3/4"	101-107	101-207
11"	101-110	101-210

LENGTH	STEEL SHAFT		ALUM. SHAFT	
	RIGHT	LEFT	RIGHT	LEFT
7 3/4"	101-277	N/A	N/A	N/A
8 1/2"	101-285	101-385	101-485	101-585
8 3/4"	101-287	101-387	101-487	101-587
9"	101-290	101-390	101-490	101-590
9 1/4"	101-292	101-392	101-492	101-592
9 1/2"	101-295	101-395	101-495	101-595
9 3/4"	101-297	101-397	101-497	101-597
10"	101-300	101-400	101-500	101-600

# MODIFIED ADJUSTABLE A-ARM-TYPE 3

- ★FITS SEVERAL POPULAR MODIFIED CHASSIS
- ★ALLOWS FOR EASY ADJUSTMENT WHILE MOUNTED IN PLACE
- ★ACCEPTS 5/8" ROD ENDS & #101-018 & #100-918 SMALL SCREW-IN BALL JOINTS

**PART #101-6150**

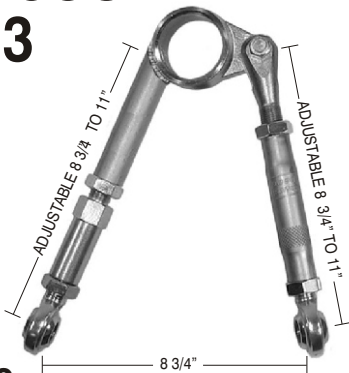

NOTE: WE BUILD UPPER AND LOWER A-ARMS, AND MANY OTHER SUSPENSION PIECES EXCLUSIVELY FOR MANY CHASSIS BUILDERS, DIRT AND PAVEMENT. IF YOU WOULD LIKE A QUOTE, SEND US A SAMPLE OF THE DESIRED PART AND THE QUANTITIES TO BE PURCHASED PER ORDER OR PER YEAR. WE WILL RETURN A QUOTE AS SOON AS POSSIBLE. WE FABRICATE MANY EXCLUSIVE PIECES NOT CATALOGED.

# MODIFIED A-ARMS 1964-72 CHEVELLE

- ★STEEL SHAFTS
- ★ACCEPTS #101-018 OR #100-918 SMALL SCREW-IN BALL JOINT
- ★BOLTS DIRECTLY TO 64-72 CHEVELLE STOCK MOUNT
- ★DESIGNED FOR USE WITH 74-78 PINTO SPINDLE
- ★3 DIFFERENT LENGTHS FOR LEFT SIDE
- ★2 DIFFERENT LENGTHS FOR RIGHT SIDE

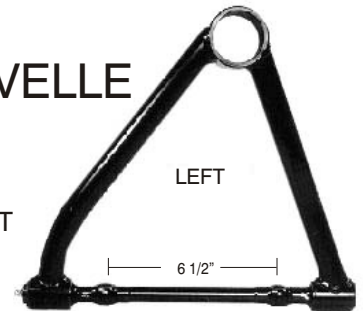

LENGTH	LEFT	RIGHT
9 1/4"	N/A	101-052
9 3/4"	101-051	101-054
10 1/4"	101-053	N/A
10 3/4"	101-055	N/A

Place your order at (479) 646-6988, Fax to (479) 646-5939, or visit [www.southwestspeed.com](http://www.southwestspeed.com)

# UPPER A-ARMS GM METRIC

- ★BOLTS TO ALL STOCK GM METRIC (78-88 CHEVELLE, MONTE CARLO, EL CAMINO, MALIBU, ETC.) MOUNTS
- ★STEEL CROSS SHAFTS
- ★ACCEPTS:
  - \*#101-017 STOCK 73-88 CHEVELLE, MONTE, ETC. BOLT-IN BALL JOINTS OR
  - \*#101-018 SMALL SCREW-IN BALL JOINTS

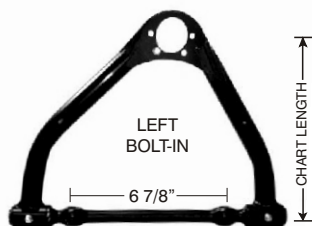
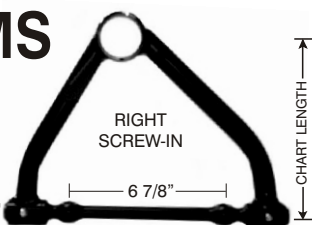

DESCRIPTION	LEFT	RIGHT
SCREW-IN METRIC, 8"	N/A	101-058
SCREW-IN METRIC, 8 1/2"	101-057	101-060
SCREW-IN METRIC, 9"	101-059	N/A
BOLT-IN METRIC, 8"	N/A	101-068
BOLT-IN METRIC, 8 1/2"	101-067	101-070
BOLT-IN METRIC, 9"	101-069	N/A

# CAMARO

- ★FITS STOCK CAMARO A-ARM MOUNTS
- ★STEEL CROSS SHAFTS
- ★ACCEPTS:
  - \*#101-016 LARGE RACING BOLT-IN OR
  - \*#101-017 STOCK 70-81 CAMARO BOLT-IN BALL JOINTS

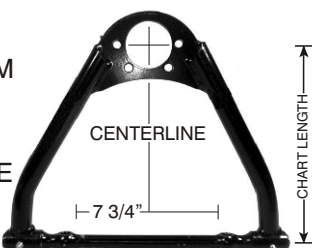

DESCRIPTION	BALL JOINTS	
	#101-016	#101-017
CAMARO TRIANGLE, 8"	106-080	106-060
CAMARO TRIANGLE, 8 1/4"	106-082	106-062
CAMARO TRIANGLE, 8 1/2"	106-085	106-065
CAMARO TRIANGLE, 8 3/4"	106-087	106-067
CAMARO TRIANGLE, 9"	106-090	106-070
CAMARO TRIANGLE, 9 1/4"	106-092	106-072
CAMARO TRIANGLE, 9 1/2"	106-095	106-075

NOTE: SEE THE NEW PRODUCTS SECTION FOR TUBULAR A-ARMS

# ROD ENDS W/ADAPTERS

- ★ADAPTS LOWER A-ARM TO INNER BUSHING MOUNT
- ★5/8" OR 3/4" ROD ENDS

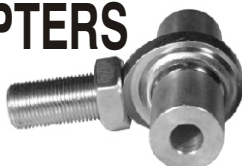

DESCRIPTION	PART #
5/8" ROD END WITH ADAPTERS	101-775
3/4" ROD END WITH ADAPTERS	101-776
5/8" ADAPTER ONLY (SOLD EACH)	101-777
3/4" ADAPTER ONLY (SOLD EACH)	101-778

# SLEEVE & BUSHING

- ★USED TO CONSTRUCT STRUT LOWER A-ARM
- ★REPLACEMENT STRUT BUSHING



PART #101-782

PART #101-780

# LOWER A-ARMS

- ★LIGHTWEIGHT ROUND TUBING
- ★ACCEPTS BOTH 5/8" OR 3/4" STRUT BARS & EITHER PRESS-IN OR SCREW-IN BALL JOINTS
- ★MOUNTS WITH EITHER RUBBER BUSHING MOUNTS OR 5/8" OR 3/4" ROD ENDS

## RUBBER BUSHING MOUNT



LENGTH	DESCRIPTION	PRESS-IN	SCREW-IN
15 5/8"	RUBBER BUSHING	101-806	101-836
16 5/8"	RUBBER BUSHING	101-808	101-838
17 5/8"	RUBBER BUSHING	101-810	101-840
18"	RUBBER BUSHING	101-812	101-842
18 5/8"	RUBBER BUSHING	101-813	101-843
19"	RUBBER BUSHING	101-814	101-844

## 5/8" ROD END MOUNT



LENGTH	DESCRIPTION	PRESS-IN	SCREW-IN
15 5/8"	5/8" ROD END	101-866	101-876
16 5/8"	5/8" ROD END	101-868	101-878
17 5/8"	5/8" ROD END	101-870	101-880
18"	5/8" ROD END	101-872	101-882
18 5/8"	5/8" ROD END	101-873	101-883
19"	5/8" ROD END	101-874	101-884

## 3/4" ROD END MOUNT

LENGTH	DESCRIPTION	PRESS-IN	SCREW-IN
15 5/8"	3/4" ROD END	101-886	101-896
16 5/8"	3/4" ROD END	101-888	101-898
17 5/8"	3/4" ROD END	101-890	101-900
18"	3/4" ROD END	101-892	101-902
18 5/8"	3/4" ROD END	101-893	101-903
19"	3/4" ROD END	101-894	101-904

## MONO BALL BALL JOINT RUBBER BUSHING MOUNT

- ★SOLID ROD END OR 3/4" ROD END STRUT MOUNT
- ★USES #102-992 MONO BALL



DESCRIPTION	PART #
RUBBER MOUNT MONO BALL, 15"	101-8061
RUBBER MOUNT MONO BALL, 19"	101-8151
MONO BALL STUD	101-969
REPLACEMENT MONO BALL	102-992
MONO BALL SNAP RING	102-9922

SEE PAGE 42 & 43 FOR MONO BALL JOINTS, BALLS, & STUDS

Place your order at (479) 646-6988, Fax to (479) 646-5939, or visit [www.southwestspeed.com](http://www.southwestspeed.com)

# STOCK LOWER A-ARMS

## 64-72 CHEVELLE, MONTE, ETC.

★ 100 % NEW STAMPINGS

★ AVAILABLE WITH EITHER AN OVAL OR ROUND REAR BUSHING HOLE

★ RETAINS STOCK GEOMETRY

★ USE RUBBER, STEEL, OR NYLON BUSHINGS

★ WILL FIT 64-72 CHEVELLE, EL CAMINO, MALIBU, & MONTE CARLO (INCLUDING GMC CABALLERO & SPRINT TRUCKS), 64-72 BUICK CENTURY, LUXUS, REGAL, SKYLARK, & SPECIAL (RWD), 66-72 OLDSMOBILE CUTLASS, F85, VISTA CRUISER, 4-4-2, & CALAIS (RWD), 64-72 PONTIAC LEMANS, GRAND AM, GRAND LEMANS, GTO, TEMPEST, & T37, AND 69-72 PONTIAC GRAND PRIX



#101-805  
RIGHT SIDE WITH  
OVAL REAR

DESCRIPTION	PART #
64-72 LOWER, LEFT, OVAL REAR	101-803
64-72 LOWER, LEFT, ROUND REAR	101-8031
64-72 LOWER, RIGHT, OVAL REAR	101-805
64-72 LOWER, RIGHT, ROUND REAR	101-8051

NOTE: SEE THE NEW PRODUCTS SECTION, AS WE KNOW HAVE MORE STOCK LOWER A-ARMS, AS WELL AS MANY TUBULAR LOWERS AS WELL

## BUSHINGS

★ OVAL BUSHINGS WILL FIT THE REAR OF THE #101-803 & #101-805

★ ROUND BUSHINGS WILL FIT THE FRONT OF THE #101-803 & #101-805 AND THE FRONT & REAR OF #101-8031 & #101-8051

★ AVAILABLE IN RUBBER, STEEL, & NYLON



#101-703  
OVAL - RUBBER

#101-704  
ROUND - RUBBER

#101-7342  
ROUND - NYLON

DESCRIPTION	PART #
64-72 BUSHING, OVAL, RUBBER	101-703
64-72 BUSHING, ROUND, RUBBER	101-704
64-72 BUSHING, OVAL, STEEL	101-735
64-72 BUSHING, ROUND, STEEL	101-734
64-72 BUSHING, OVAL, NYLON	101-7352
64-72 BUSHING, ROUND, NYLON	101-7342

## STRUT BARS

★ 2 LIGHTWEIGHT TUBULAR DESIGNS AVAILABLE

★ FITS STRUT LOWER A-ARMS

★ 5/8" OR 3/4" LEFT HAND THREADS

★ PLATED FOR EXTENDED PARTS LIFE



5/8" PART #101-996  
3/4" PART #101-997

3/4" PART #  
101-999

## LOWER A-ARM BUSHINGS

★ 3 TYPES OF BUSHINGS AVAILABLE TO FIT ALMOST EVERY LOWER A-ARM APPLICATION:

- \* 2 PIECE SOLID STEEL BUSHINGS WITH OUTER SHELL & GREASEABLE INNER SLEEVE
- \* 2 PIECE NYLON BUSHINGS WITH NYLON OUTER SHELL & STEEL INNER SLEEVE
- \* 1 PIECE STOCK RUBBER BUSHINGS

★ SEE CHART ON PAGES 40 & 41 TO SEE WHICH BUSHINGS FIT YOUR APPLICATION



#101-730  
STEEL

#101-7302  
NYLON

#101-7303  
RUBBER

#101-681  
3 PIECE NYLON

#101-7352  
NYLON - OVAL

#101-7353  
RUBBER - OVAL

#101-736  
STEEL

#101-7362  
NYLON

#101-7363  
RUBBER

LENGTH	O.D.	I.D.	STEEL	NYLON	RUBBER
1.89"	1.328"	3/4"	101-729	101-7292	101-7293
2.40"	1.650"	1/2"	101-730	101-7302	101-7303
2.40"	1.650"	1/2"	101-681*		
2.40"	1.650"	9/16"	101-7307	101-7308	101-7309
2.40"	1.900"	1/2"	101-732	101-7322	101-7323
2.40"	1.900"	1/2"	101-683*		
2.40"	1.900"	9/16"	101-7327	101-7328	101-7329
2.40"	1.420"	1/2"	101-734	101-7342	101-7343
2.40"	OVAL	1/2"	101-735	101-7352	101-7353
2.94"	1.460"	1/2"	101-736	101-7362	101-7363

\* #101-681 & #101-683 ARE A 3 PIECE DESIGN WITH A STEEL OUTSIDE, A NYLON MIDDLE, & A STEEL INSERT SLEEVE ON THE INSIDE

## INSERT SLEEVES ONLY

★ USED TO CHANGE THE I.D. ON ANY SOUTHWEST SPEED 2 OR 3 PIECE LOWER A-ARM BUSHING

DESCRIPTION	PART #
1/2" I.D. SLEEVE, 2.40" LONG	101-725
1/2" I.D. SLEEVE, 2.985" LONG	101-7252
9/16" I.D. SLEEVE, 2.40" LONG	101-726

## UPPER A-ARM BUSHINGS

★ THE SAME 3 TYPES OF BUSHINGS ARE AVAILABLE FOR UPPER A-ARMS

★ ALSO SEE THE CHARTS ON PAGES 40 & 41



#101-738  
STEEL

#101-7383  
RUBBER

LENGTH	O.D.	I.D.	STEEL	NYLON	RUBBER
1.50"	1.270"	.677"	101-738	101-7382	101-7383
1.75"	1.530"	.695"	101-740	101-7402	101-7403
1.70"	1.315"	.690"	101-742	101-7422	101-7423
1.95"	1.395"	.688"	101-744	101-7442	101-7443
1.80"	1.395"	.688"	101-745	101-7452	101-7453
1.95"	1.395"	.688"	101-746	101-7462	101-7463
1.70"	1.315"	.690"	101-747	101-7472	101-7473

Place your order at (479) 646-6988, Fax to (479) 646-5939, or visit [www.southwestspeed.com](http://www.southwestspeed.com)



# CONTROL ARM BUSHINGS & BALL JOINTS

DESCRIPTION	LOWER A-ARM BUSHINGS					UPPER A-ARM BUSHINGS					BALL JOINTS			
	YEAR	POS.	STEEL	NYLON	RUBBER	YEAR	POS.	STEEL	NYLON	RUBBER	YEAR	LOWER	YEAR	UPPER
<b>CHEVROLET CHEVELLE</b>	<b>MONTE CARLO, EL CAMINO, &amp; MALIBU</b>													
*1ST DESIGN, 1.650" O.D.	64-66*	FRONT	101-730	101-7302	101-7303	64-72	FRONT	101-738	101-7382	101-7383	64-72	101-011	64-72	101-0153
*2ND DESIGN, 1.420" O.D.	66-72*	FRONT	101-734	101-7342	101-7343		REAR	101-738	101-7382	101-7383	73-88	101-013	73-88	101-017
*ROUND, 1ST DES., 1.900" O.D.	64-66*	REAR	101-732	101-7322	101-7323	73	FRONT	101-742	101-7422	101-7423				
*ROUND, 2ND DES., 1.670" O.D.	66-72*	REAR	101-730	101-7302	101-7303		REAR	101-742	101-7422	101-7423				
*OVAL	70-72*	REAR	101-735	101-7352	101-7353	74-77	FRONT	101-744	101-7442	101-7443				
	73-74	FRONT	101-734	101-7342	101-7343		REAR	101-742	101-7422	101-7423				
		REAR	101-7327	101-7328	101-7329	78-88	FRONT	101-740	101-7402	101-7403				
	75-77	FRONT	101-7307	101-7308	101-7309		REAR	101-740	101-7402	101-7403				
		REAR	101-7327	101-7328	101-7329									
	78-88	FRONT	101-736	101-7362	101-7363									
		REAR	101-730	101-7302	101-7303									
<b>CHEVROLET CAMARO</b>														
	67-69	FRONT	101-734	101-7342	101-7343	67-69	FRONT	101-738	101-7382	101-7383	67-69	101-011	67-69	101-0153
		REAR	101-730	101-7302	101-7303		REAR	101-738	101-7382	101-7383	70-92	101-013	70-81	101-017
*1/2" I.D. HOLE	70-79*	FRONT	101-734	101-7342	101-7343	70-73	FRONT	101-742	101-7422	101-7423				
*9/16" I.D. HOLE	70-81*	FRONT	101-7307	101-7308	101-7309		REAR	101-742	101-7422	101-7423				
*1/2" I.D. HOLE	70-72*	REAR	101-730	101-7302	101-7303	74-79	FRONT	101-744	101-7442	101-7443				
*9/16" I.D. HOLE	73-81*	REAR	101-7327	101-7328	101-7329		REAR	101-742	101-7422	101-7423				
						80-81	FRONT	101-744	101-7442	101-7443				
							REAR	101-745	101-7452	101-7453				
<b>CHEVROLET IMPALA, CAPRICE, BEL AIR, &amp; BISCAYNE (INCLUDES 55, 56, &amp; 57 CHEVY)</b>														
	55-64	FRONT	101-729	101-7292	101-7293	55-70	FRONT	101-738	101-7382	101-7383	58-70	101-0102	55-70	101-0151
		REAR	101-729	101-7292	101-7293		REAR	101-738	101-7382	101-7383	71-76	101-010	71-94	101-017
*9/16" I.D. HOLE	71-96*	FRONT	101-7307	101-7308	101-7309	71-73	FRONT	101-742	101-7422	101-7423	77-94	101-013		
*1/2" I.D. HOLE	73-74*	FRONT	101-734	101-7342	101-7343		REAR	101-742	101-7422	101-7423				
	71-96	REAR	101-7327	101-7328	101-7329	74-79	FRONT	101-744	101-7442	101-7443				
							REAR	101-742	101-7422	101-7423				
						80-96	FRONT	101-744	101-7442	101-7443				
							REAR	101-744	101-7442	101-7443				
<b>CHEVROLET CHEVY II &amp; NOVA (RWD)</b>														
	68-72	FRONT	101-730	101-7302	101-7303	68-74	FRONT	101-738	101-7382	101-7383	62-67	101-0107	62-67	101-0157
		REAR	101-734	101-7342	101-7343		REAR	101-738	101-7382	101-7383	68-74	101-011	68-74	101-0153
	73-74	FRONT	101-730	101-7302	101-7303	75-79	FRONT	101-744	101-7442	101-7443	75-79	101-013	75-79	101-017
		REAR	101-730	101-7302	101-7303		REAR	101-742	101-7422	101-7423				
	75-79	FRONT	101-7307	101-7308	101-7309									
		REAR	101-7327	101-7328	101-7329									
<b>CHEVROLET CORVETTE</b>														
	63-82	FRONT	101-729	101-7292	101-7293	63-82	FRONT	101-738	101-7382	101-7383	63-82	101-0102	63-82	101-0151
		REAR	101-729	101-7292	101-7293		REAR	101-738	101-7382	101-7383				
<b>OLDSMOBILE CUTLASS, F85, VISTA CRUISER, 4-4-2, &amp; CALAIS (RWD)</b>														
	64-65	FRONT	101-732	101-7322	101-7323	65-72	FRONT	101-738	101-7382	101-7383	64-72	101-011	64-72	101-0153
		REAR	101-730	101-7302	101-7303		REAR	101-738	101-7382	101-7383	73-88	101-013	73-88	101-017
	66-68	FRONT	101-734	101-7342	101-7343	73	FRONT	101-742	101-7422	101-7423				
		REAR	101-730	101-7302	101-7303		REAR	101-742	101-7422	101-7423				
	69-72	FRONT	101-734	101-7342	101-7343	74-77	FRONT	101-744	101-7442	101-7443				
		REAR	101-735	101-7352	101-7353		REAR	101-742	101-7422	101-7423				
	73-77	FRONT	101-7307	101-7308	101-7309	78-88	FRONT	101-740	101-7402	101-7403				
		REAR	101-7327	101-7328	101-7329		REAR	101-740	101-7402	101-7403				
	78-97	FRONT	101-736	101-7362	101-7363									
		REAR	101-730	101-7302	101-7303									
<b>OLDSMOBILE CUSTOM CRUISER, DELTA, REGENCY, &amp; STARFIRE</b>														
	65-70	FRONT	101-732	101-7322	101-7323	64-73	FRONT	101-742	101-7422	101-7423	71-76	101-010	71-94	101-017
		REAR	101-730	101-7302	101-7303		REAR	101-742	101-7422	101-7423	77-94	101-013		
	71-92	FRONT	101-7307	101-7308	101-7309	74-79	FRONT	101-744	101-7442	101-7443				
		REAR	101-7327	101-7328	101-7329		REAR	101-742	101-7422	101-7423				
						80-92	FRONT	101-744	101-7442	101-7443				
							REAR	101-744	101-7442	101-7443				
<b>OLDSMOBILE OMEGA</b>														
	73-74	FRONT	101-734	101-7342	101-7343	73-74	FRONT	101-738	101-7382	101-7383	73-74	101-011	73-74	101-0153
		REAR	101-730	101-7302	101-7303		REAR	101-738	101-7382	101-7383	75-79	101-013	75-79	101-017
	75-79	FRONT	101-7307	101-7308	101-7309	75-79	FRONT	101-744	101-7442	101-7443				
		REAR	101-7327	101-7328	101-7329		REAR	101-742	101-7422	101-7423				
<b>OLDSMOBILE TORONADO</b>														
	79-85	FRONT	101-7327	101-7328	101-7329								79-85	101-017
		REAR	101-7327	101-7328	101-7329									
<b>PONTIAC GTO, LEMANS, GRAND AM (EXCEPT 85-89), GRAND LEMANS, TEMPEST, &amp; T37</b>														
*1ST DESIGN, 1.650" O.D.	64-70*	FRONT	101-730	101-7302	101-7303	64-72	FRONT	101-738	101-7382	101-7383	64-72	101-011	64-72	101-0153
*2ND DESIGN, 1.420" O.D.	64-72*	FRONT	101-734	101-7342	101-7343		REAR	101-738	101-7382	101-7383	73-81	101-013	73-81	101-017
*ROUND, 1ST DES., 1.900" O.D.	64-66*	REAR	101-732	101-7322	101-7323	73	FRONT	101-742	101-7422	101-7423				
*OVAL	64-72*	REAR	101-735	101-7352	101-7353		REAR	101-742	101-7422	101-7423				
	73-77	FRONT	101-7307	101-7308	101-7309	74-77	FRONT	101-744	101-7442	101-7443				
		REAR	101-7327	101-7328	101-7329		REAR	101-742	101-7422	101-7423				
	78-81	FRONT	101-736	101-7362	101-7363	78-81	FRONT	101-740	101-7402	101-7403				
		REAR	101-730	101-7302	101-7303		REAR	101-740	101-7402	101-7403				
<b>PONTIAC BONNEVILLE, CATALINA, EXECUTIVE, GRANDVILLE, GRAND SAFARI (73-76), &amp; STARCHIEF (RWD)</b>														
	65-70	FRONT	101-734	101-7342	101-7343	71-73	FRONT	101-742	101-7422	101-7423	71-76	101-010	71-89	101-017
		REAR	101-735	101-7352	101-7353		REAR	101-742	101-7422	101-7423	77-89	101-013		
	71-81	FRONT	101-7307	101-7308	101-7309	74-79	FRONT	101-744	101-7442	101-7443				
		REAR	101-7327	101-7328	101-7329		REAR	101-742	101-7422	101-7423				
	82-86	FRONT	101-736	101-7362	101-7363	80-81	FRONT	101-744	101-7442	101-7443				
		REAR	101-730	101-7302	101-7303		REAR	101-744	101-7442	101-7443				
						82-86	FRONT	101-740	101-7402	101-7403				
							REAR	101-740	101-7402	101-7403				
<b>PONTIAC FIREBIRD &amp; TRANS AM</b>														
	67-69	FRONT	101-730	101-7302	101-7303	67-69	FRONT	101-738	101-7382	101-7383	67-69	101-011	67-69	101-0153
		REAR	101-734	101-7342	101-7343		REAR	101-738	101-7382	101-7383	70-94	101-013	70-81	101-017
	70-81	FRONT	101-7307	101-7308	101-7309	70-75	FRONT	101-742	101-7422	101-7423				
		REAR	101-7327	101-7328	101-7329		REAR	101-742	101-7422	101-7423				
	82-92</													

# CONTROL ARM BUSHINGS & BALL JOINTS

DESCRIPTION	LOWER A-ARM BUSHINGS					UPPER A-ARM BUSHINGS					BALL JOINTS			
	YEAR	POS.	STEEL	NYLON	RUBBER	YEAR	POS.	STEEL	NYLON	RUBBER	YEAR	LOWER	YEAR	UPPER
<b>PONTIAC GRAND PRIX</b>														
	69-72	FRONT	101-734	101-7342	101-7343	69-72	FRONT	101-738	101-7382	101-7383	69-72	101-011	69-72	101-0153
		REAR	101-735	101-7352	101-7353		REAR	101-738	101-7382	101-7383	73-87	101-013	73-87	101-017
	73-77	FRONT	101-7307	101-7308	101-7309	73	FRONT	101-742	101-7422	101-7423				
		REAR	101-7327	101-7328	101-7329		REAR	101-742	101-7422	101-7423				
	78-87	FRONT	101-736	101-7362	101-7363	74-77	FRONT	101-744	101-7442	101-7443				
		REAR	101-730	101-7302	101-7303		REAR	101-742	101-7422	101-7423				
						78-87	FRONT	101-740	101-7402	101-7403				
							REAR	101-740	101-7402	101-7403				
<b>PONTIAC PARISIENNE &amp; SAFARI WAGON (87 &amp; UP)</b>														
	83-89	FRONT	101-7307	101-7308	101-7309	83-89	FRONT	101-744	101-7442	101-7443	83-89	101-013	83-89	101-017
		REAR	101-7327	101-7328	101-7329		REAR	101-744	101-7442	101-7443				
<b>PONTIAC PHOENIX</b>														
	77-79	FRONT	101-7307	101-7308	101-7309	77-79	FRONT	101-744	101-7442	101-7443	77-79	101-013	77-79	101-017
		REAR	101-7327	101-7328	101-7329		REAR	101-742	101-7422	101-7423				
<b>PONTIAC VENTURA</b>														
	71-74	FRONT	101-730	101-7302	101-7303	71-74	FRONT	101-738	101-7382	101-7383	71-74	101-011	71-74	101-0153
		REAR	101-734	101-7342	101-7343		REAR	101-738	101-7382	101-7383	75-77	101-013	75-77	101-017
	75-77	FRONT	101-7307	101-7308	101-7309	75-77	FRONT	101-744	101-7442	101-7443				
		REAR	101-7327	101-7328	101-7329		REAR	101-742	101-7422	101-7423				
<b>BUICK CENTURY, LUXUS, REGAL, SKYLARK (64-72), &amp; SPECIAL (RWD)</b>														
*1ST DESIGN, 1.650" O.D.	64-67*	FRONT	101-730	101-7302	101-7303	66-72	FRONT	101-738	101-7382	101-7383	64-72	101-011	64-72	101-0153
*2ND DESIGN, 1.420" O.D.	64-72*	FRONT	101-734	101-7342	101-7343		REAR	101-738	101-7382	101-7383	73-87	101-013	73-87	101-017
*ROUND, 1ST DES., 1.900" O.D.	64-65*	REAR	101-732	101-7322	101-7323	73	FRONT	101-742	101-7422	101-7423				
*ROUND, 2ND DES., 1.670" O.D.	66-72*	REAR	101-730	101-7302	101-7303		REAR	101-742	101-7422	101-7423				
	73-74	FRONT	101-734	101-7342	101-7343	74-77	FRONT	101-744	101-7442	101-7443				
		REAR	101-7327	101-7328	101-7329		REAR	101-742	101-7422	101-7423				
	75-77	FRONT	101-7307	101-7308	101-7309	78-88	FRONT	101-740	101-7402	101-7403				
		REAR	101-7327	101-7328	101-7329		REAR	101-740	101-7402	101-7403				
	78-88	FRONT	101-736	101-7362	101-7363									
		REAR	101-730	101-7302	101-7303									
<b>BUICK CENTURION, ELECTRA, ESTATE WAGON, INVICTA, LESABRE, &amp; WILDCAT (RWD)</b>														
	71-89	FRONT	101-7307	101-7308	101-7309	71-73	FRONT	101-742	101-7422	101-7423	63-70	101-0109	63-70	101-0159
		REAR	101-7327	101-7328	101-7329		REAR	101-742	101-7422	101-7423	71-76	101-010	71-94	101-017
						74-79	FRONT	101-744	101-7442	101-7443	77-91	101-013		
							REAR	101-742	101-7422	101-7423				
						80-89	FRONT	101-744	101-7442	101-7443				
							REAR	101-744	101-7442	101-7443				
<b>BUICK APOLLO &amp; SKYLARK (RWD) (75-79)</b>														
	73-74	FRONT	101-730	101-7302	101-7303	73-74	FRONT	101-738	101-7382	101-7383	73-74	101-011	73-74	101-0153
		REAR	101-734	101-7342	101-7343		REAR	101-738	101-7382	101-7383	75-79	101-013	75-79	101-017
	75-79	FRONT	101-7307	101-7308	101-7309	75-79	FRONT	101-744	101-7442	101-7443				
		REAR	101-7327	101-7328	101-7329		REAR	101-742	101-7422	101-7423				
<b>BUICK RIVIERA</b>														
	71-78	FRONT	101-7307	101-7308	101-7309	71-73	FRONT	101-742	101-7422	101-7423	63-70	101-0109	63-70	101-0159
		REAR	101-7327	101-7328	101-7329		REAR	101-742	101-7422	101-7423	71-85	101-017	71-76	101-010
	79-85	FRONT	101-7327	101-7328	101-7329	74-78	FRONT	101-744	101-7442	101-7443	77-78		77-78	101-013
		REAR	101-7327	101-7328	101-7329		REAR	101-742	101-7422	101-7423				
<b>FORD COUNTRY SQUIRE, CROWN VICTORIA, CUSTOM GALAXIE, LTD, &amp; LTD CROWN VICTORIA</b>														
	65-78	SINGLE			101-6993	65-72	FRONT			101-7503	57-64	101-0144	57-78	101-0189
							REAR			101-7503	65-72	101-0146		
						73-78	FRONT			101-7513	73-78	101-0146*		
							REAR			101-7513	*BOLT-ON TYPE			
											78-94	101-0142		
<b>FORD MUSTANG &amp; MUSTANG II</b>														
	67-73				101-6943	74-78	FRONT			101-7493	74-78	101-0136	74-78	101-0189
					101-6953		REAR			101-7493	79-92	101-0142		
	74-78	SINGLE			101-6963									
	79-83	FRONT			101-6973									
		REAR			101-6983									
<b>FORD PINTO</b>														
	74-80	SINGLE			101-6963	74-80	FRONT			101-7493	74-80	101-0136	71-80	101-0189
							REAR			101-7493				
<b>FORD THUNDERBIRD</b>														
	67-79	SINGLE			101-6993	67-72	FRONT			101-7503	58-60	101-0144	58-60	101-0189
	80-83	FRONT			101-6973		REAR			101-7503	67-71	101-0146	67-79	101-0189
		REAR			101-6983	72-79	FRONT			101-7513	72-79	101-0146*		
							REAR			101-7513	*BOLT-ON TYPE			
											80-88	101-0142		
<b>FORD GRANADA</b>														
	75-80	SINGLE			101-6953						81-82	101-0142		
	81-82	FRONT			101-6973									
		REAR			101-6983									
<b>FORD ELITE, FAIRLANE, LTD II, &amp; TORINO (INCLUDING RANCHERO)</b>														
	66	SINGLE			101-6943	72	FRONT			101-7503	72-79	101-0146*	72-79	101-0189
	67-71				101-6943		REAR			101-7503	*BOLT-ON TYPE			
					101-6953	72-79	FRONT			101-7513				
	72-79	SINGLE			101-6993		REAR			101-7513				
<b>FORD FAIRMONT</b>														
	78-83	FRONT			101-6973						78-83	101-0142		
		REAR			101-6983									
<b>FORD MAVERICK</b>														
	70-74	SINGLE			101-6943									
	75-77	SINGLE			101-6953									

- ★STEEL BUSHINGS ARE 2 PIECE SOLID WITH OUTER SHELL & A GREASEABLE INNER SLEEVE
- ★NYLON BUSHINGS ARE 2 PIECE WITH NYLON OUTER SHELL & A STEEL INNER SLEEVE
- ★RUBBER BUSHINGS ARE 1 PIECE STOCK BUSHINGS
- ★BALL JOINTS COME WITH NUT, COTTER PIN, GREASE FITTING, & BOOT

Place your order at (479) 646-6988, Fax to (479) 646-5939, or visit [www.southwestspeed.com](http://www.southwestspeed.com)

# LOWER BALL JOINTS

MOST POPULAR LOWER BALL JOINT;  
 FITS ALL PRESS-IN RACING APPLICATIONS  
 ALSO 71-76 IMPALA AMONG OTHERS\*;  
 2.184" O.D.; AVAILABLE IN MONO-BALL  
 STYLE: PART #100-910 **PART #101-010**



LOWER PRESS-IN BALL JOINT;  
 FITS 64-72 CHEVELLE, MONTE CARLO, ETC.,  
 & 67-69 CAMARO, AMONG OTHERS\*;  
 2.011" O.D. **PART #101-011**



LOWER BALL JOINT TO RAISE THE ROLL CENTER  
 POPULAR TAPER; USE #101-002 SLEEVE OR  
 WELD IN; 1.980" O.D. **PART #101-012**



LOWER PRESS-IN BALL JOINT;  
 FITS S-10, 70-92 CAMARO, 73-88 CHEVELLE,  
 MONTE CARLO, ETC., & 77-94 IMPALA,  
 AMONG OTHERS\*; 2.090" O.D. **PART #101-013**



LOWER LARGE SCREW-IN BALL JOINT;  
 LARGE TAPER, OFTEN REFERRED TO AS THE  
 "LARGE CHRYSLER"; FITS POPULAR STRUT  
 APPLICATIONS; AVAILABLE IN MONO-BALL  
 STYLE: PART #100-914 **PART #101-014**



LOWER BALL JOINT;  
 FITS 58-70 IMPALA & 63-82 CORVETTE,  
 AMONG OTHERS\* **PART #101-0102**



# UPPER BALL JOINTS

SCREW-IN UPPER BALL JOINT;  
 FITS ALL SCREW-IN UPPER A-ARMS;  
 FITS RACING & PINTO SPINDLES  
 AVAILABLE IN MONO-BALL  
 STYLE PART #100-918 **PART #101-018**



MOST POPULAR BOLT-IN UPPER;  
 FITS ALL SOUTHWEST SPEED 4 BOLT  
 A-ARMS (EXCEPT #101-067 TO #101-070  
 AND #106-060 TO #106-075)  
 FITS RACING & PINTO SPINDLES  
**PART #101-016**



UPPER BOLT-IN BALL JOINT TO RAISE THE  
 ROLL CENTER; FITS ALL SOUTHWEST SPEED  
 4 BOLT A-ARMS (EXCEPT #101-067 TO  
 #101-070 AND #106-060 TO #106-075)  
 FITS RACING & PINTO SPINDLES **PART #101-020**



FITS STOCK FULL SIZE CHEVY, 71-94 IMPALA,  
 70-81 CAMARO, 73-88 CHEVELLE, MONTE  
 CARLO, ETC., AMONG OTHERS\*;  
 FITS SOUTHWEST SPEED 4 BOLT A-ARMS  
 #101-067 TO #101-070 (GM METRIC) AND  
 #106-060 TO #106-075 (CAMARO)  
**PART #101-017**



FITS 67-69 CAMARO,  
 64-72 CHEVELLE, MONTE CARLO,  
 ETC., AMONG OTHERS\* **PART #101-0153**



3-BOLT BALL JOINT; FITS STOCK  
 FULL SIZE CHEVY, 55-70 IMPALA &  
 63-82 CORVETTE, AMONG OTHERS\*  
**PART #101-0151**



\*SEE THE CHART ON PAGE 40 & 41 FOR MANY MORE APPLICATIONS OF ALL AVAILABLE BALL JOINTS

# LOW FRICTION PRECISION BALL JOINTS

★PRECISION BALL JOINTS OFFER VERY LOW RESISTANCE WHILE STILL FULLY CAPTURING THE BALL TO MAINTAIN ALIGNMENT; RUGGED HOUSINGS WILL WITHSTAND IMPACTS THAT WILL DESTROY OTHER BALL JOINTS; ALSO, THESE ALLOW YOU TO CHANGE THE BALL STUDS TO MODIFY ROLL CENTER

★IN THE CHART BELOW, FIND YOUR ORIGINAL SWS BALL JOINT #, THEN INTERCHANGE IT TO SEE WHICH PRECISION BJ WILL FIT YOUR APPLICATION



Description	Original SWS Ball Joints	Complete Low Friction Precision Ball Joints W/			Individual Precision Ball Joint Pieces							
		Alum Cap	Steel Cap		Housings With:		Studs Only					
					Alum Cap	Steel Cap	Standard	+ .100"	+ .200"	+ .300"	+ .400"	+ .500"
LOWER PRESS-IN, LARGE	101-010	100-9310	100-9311	100-9460	100-9461	100-9464	100-9465	100-9466	100-9467	100-9468	100-9469	
LOWER SCREW-IN LARGE, CHEVY	-	100-9314	100-9315	100-9520	100-9521	100-9464	100-9465	100-9466	100-9467	100-9468	100-9469	
LOWER SCREW-IN LARGE, CHRYSLER	101-014	100-9318	100-9319	100-9520	100-9521	100-9524	100-9525	100-9526	100-9527	100-9528	100-9529	
LOWER PRESS-IN, 1964-72	101-011	100-9362	100-9363	100-9470	100-9471	100-9474	100-9475	100-9476	100-9477	100-9478	100-9479	
LOWER PRESS-IN, RAISE ROLL	101-012	100-9364	100-9365	100-9490	100-9491	100-9494	100-9495	100-9496	100-9497	100-9498	100-9499	
LOWER PRESS-IN, 1970-81 CAMARO	101-013	100-9366	100-9367	100-9500	100-9501	100-9504	100-9505	100-9506	100-9507	100-9508	100-9509	
LOWER SCREW-IN, SMALL	101-0134	100-9368	100-9369	100-9530	100-9531	100-9534	100-9535	100-9536	100-9537	100-9538	100-9539	
UPPER SCREW-IN, SMALL	101-018	100-9398	100-9399	100-9530	100-9531	100-9744	100-9745	100-9746	100-9747	100-9748	100-9749	
UPPER 3-BOLT, 1963-82 CORVETTE	101-0151	100-9390	100-9391	100-9700	100-9701	100-9704	100-9705	100-9706	100-9707	100-9708	100-9709	
UPPER 3-BOLT, 1971-80 PINTO	101-0189	100-9400	100-9401	100-9800	100-9801	100-9804	100-9805	100-9806	100-9807	100-9808	100-9809	
UPPER 4-BOLT, 1964-72	101-0153	100-9392	100-9393	100-9720	100-9721	100-9704	100-9705	100-9706	100-9707	100-9708	100-9709	
UPPER 4-BOLT, STANDARD TAPER	101-016	100-9394	100-9395	100-9740	100-9741	100-9744	100-9745	100-9746	100-9747	100-9748	100-9749	
UPPER 4-BOLT, STOCKER	101-017	100-9396	100-9397	100-9720	100-9721	100-9764	100-9765	100-9766	100-9767	100-9768	100-9769	
UPPER 4-BOLT, RAISE ROLL	101-020	100-9402	100-9403	100-9740	100-9741	100-9824	100-9825	100-9826	100-9827	100-9828	100-9829	

Place your order at (479) 646-6988, Fax to (479) 646-5939, or visit [www.southwestspeed.com](http://www.southwestspeed.com)



# BALL JOINT SLEEVES

## SMALL SMOOTH

ACCEPTS #101-012 BALL JOINT  
(PRESSES INTO IMPALA  
LOWER OR #101-004 SLEEVE)

**PART #101-002**



## MEDIUM SMOOTH

ACCEPTS #101-012 BALL JOINT &  
WELDS IN LOWER A-ARMS

**PART #101-003**

## LARGE SMOOTH

ACCEPTS #101-010 & #100-910  
BALL JOINTS

**PART #101-004**



## SMALL THREADED

ACCEPTS #101-018 & #100-918  
BALL JOINTS

**PART #101-006**

## LARGE THREADED

ACCEPTS #101-014 & #100-914  
BALL JOINTS

**PART #101-007**



## SMALL THREADED W/ SHOULDER

ACCEPTS #101-018 & #100-918  
BALL JOINTS

**PART #101-008**

## LARGE THREADED W/ SHOULDER

ACCEPTS #101-014 & #100-914  
BALL JOINTS

**PART #101-009**



I.D.	INSIDE-TYPE	O.D.	SHOULDER OD	THICK	PART #
2"	SMOOTH	2 3/16"		1"	101-002
2"	SMOOTH	2 3/8"		1"	101-003
2 3/16"	SMOOTH	2 1/2"		1"	101-004
1 13/16"	THREAD	2 1/4"		1 1/8"	101-006
2"	THREAD	2 7/16"		1"	101-007
1 13/16"	THREAD	2 3/16"	2 1/2"	1"	101-008
2"	THREAD	2 5/16"	2 5/8"	1"	101-009

SEE PAGE 36 FOR RACING-TYPE BALL JOINT HOLDERS

# MONO BALL STUDS

## ★ REPLACEMENT STUDS

★ #101-968 FITS #100-916 & #100-918

★ #101-967 FITS #100-910

★ #101-9688 FITS #101-914

★ #101-969 IS USED WITH

#101-8061 & #101-8151

MONO BALL LOWER A-ARMS (PAGE 38)



DESCRIPTION	PART #
UPPER	101-968
PRESS-IN LOWER	101-967
SCREW-IN LOWER, SHORT, LARGE CHRY.	101-9688
SCREW-IN LOWER, TALL, LARGE CHRY.	101-969

# BALL JOINT REAMERS

★ TWO POPULAR SIZES

★ MADE FROM HIGH QUALITY TOOL  
STEEL; SMOOTH BORING

★ MINIMAL TOOL WEAR

★ BOTH REAMERS ARE 1" O.D. ON  
THE TOP & 1/2" O.D. ON THE  
BOTTOM WITH 1/2" SHANK

SEE BELOW FOR YOUR APPLICATION  
& CORRECT REAMER



DESCRIPTION	APPLICATION	PART #
1 1/2" TAPER PER FOOT	MOST TIE ROD SHOCK EYES & 101-011, 101-014, 101-016, & 101-018 BALL JOINTS & 100-914, 100-916, & 100-918 MONO BALL JOINTS	807-700
4" LONG FLUTES 5.625° OF TAPER		
2" TAPER PER FOOT	101-010, 101-012, 101-013, 101-017, & 101-020 BALL JOINTS & 100-910 MONO BALL JOINT	807-710
3" LONG FLUTES 7.5° OF TAPER		

# BALL JOINT ADAPTER BUSHING



★ REDUCES LARGE CHRYSLER TAPER  
TO POPULAR CHEVY LOWER BALL  
JOINT #101-010

**PART #103-900**

# BALL JOINT SOCKETS

★ 1/2" DRIVE SOCKETS FOR  
INSTALLING & REMOVING  
SCREW-IN BALL JOINTS

★ AVAILABLE FOR  
UPPER & LOWER JOINTS,  
#101-018 & #101-014

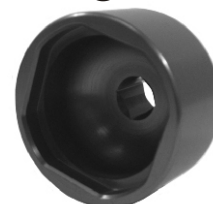

DESCRIPTION	PART #
UPPER B.J. SOCKET FOR #101-018	790-205
LOWER B.J. SOCKET FOR #101-014	790-206

# BALL JOINT BOSSES

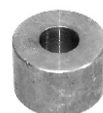

USE WITH  
GM LOWER  
BALL JOINT

**PART #**  
**105-010**



USE WITH  
CHRYSLER  
LOWER

**PART #**  
**105-012**



USE WITH  
GM UPPER  
BALL JOINT

**PART #**  
**105-014**



5/8"-18  
THREADED

**PART #**  
**105-024**

# MONO BALLS

★ CASE HARDENED STEEL

★ HARD CHROME PLATED

O.D.	BORE SIZE	PART #
1"	1/2"	102-988
1 3/16"	5/8"	102-989
1 5/16"	5/8"	102-990
1 7/16"	3/4"	102-992



Place your order at (479) 646-6988, Fax to (479) 646-5939, or visit [www.southwestspeed.com](http://www.southwestspeed.com)

# CENTER LINKS

- ★ ALL SOUTHWEST SPEED CENTER LINKS ARE BRAND NEW & DESIGNED TO REPLACE STOCK LINKS WITH NO MODIFICATIONS
- ★ NECESSARY HARDWARE (NUTS, COTTER PINS, GREASE FITTINGS, BUMPERS, ETC) IS INCLUDED
- ★ ALWAYS CHECK THE CHART ON PAGE 46 & 47 FOR MANY MORE APPLICATIONS & TO MAKE SURE YOU GET THE CORRECT ITEM



DESCRIPTION	PART #
64-67 CHEVELLE, M/C, 64-65 CUTLASS***	107-226
68-72 CHEVELLE, M/C, 68-72 CUT, GTO***	107-227
73-77 CHEVELLE, CUTLASS, GTO***	107-228
78-88 CHEVELLE, M/C, CUTLASS, GTO***	107-232
73-77 MONTE CARLO***	107-2282
67-69 CAMARO, 68-74 CHEVY II, NOVA***	107-2286
70-73 CAMARO (P/S), 74-81 CAMARO***	107-229
70-73 CAMARO (MANUAL STEER)***	107-2288
82-92 CAMARO, FIREBIRD, TRANS AM***	107-2292
63-64 IMPALA	107-2237
65-66 IMPALA, CAPRICE, BEL AIR***	107-2246
67-70 IMPALA, CAPRICE, BEL AIR***	107-2248
71-72 IMPALA, OLDS, PONT., BUICK***	107-225
73-76 IMPALA, OLDS, PONT., BUICK***	107-2252
77-89 IMPALA, OLDS, PONT., BUICK***	107-2254
63-82 CORVETTE (POWER STEER)***	107-2396
63-82 CORVETTE (MANUAL STEER)***	107-2397
64-65 GTO, 64-65 CUTLASS°, 66-67 CUT 64 CHEVELLE° (°1ST DES, 13/16"OD)***	107-224
66-67 GTO, LEMANS***	107-2242

\*\*\*THESE ARE JUST A FEW OF THE GENERAL APPLICATIONS; SEE THE CHARTS ON PAGE 46 & 47 FOR MORE APPLICATIONS & TO MAKE SURE YOU GET THE CORRECT ITEM

TIE ROD ENDS ARE LISTED ON PAGE 48 & 49



# IDLER ARMS

- ★ ALL SOUTHWEST SPEED IDLER ARMS ARE BRAND NEW & DESIGNED TO REPLACE STOCK ARMS WITH NO MODIFICATIONS
- ★ NECESSARY HARDWARE (GREASE FITTINGS, BOOTS, ETC) IS INCLUDED
- ★ ALWAYS CHECK THE CHART ON PAGE 46 & 47 FOR MANY MORE APPLICATIONS & TO MAKE SURE YOU GET THE CORRECT ITEM



DESCRIPTION	PART #
64-67 CHEVELLE, M/C, 64-65 CUTLASS***	107-250
68-72 CHEVELLE, 66-72 CUT, 64-72 GTO**	107-251
73-74 CHEVELLE, M/C, CUTLASS, GTO***	107-2494
75-77 CHEVELLE, GTO, GRAND PRIX***	107-252
78-88 CHEVELLE, M/C, CUTLASS, GTO***	107-256
67 CAMARO, FIREBIRD, TRANS AM***	107-2486
68-69 CAMARO, 68 FIRE., 68-74 NOVA***	107-2488
70-81 CAMARO, 72-81 FIRD., 75-79 NOVA**	107-253
82-92 CAMARO, FIREBIRD, TRANS AM***	107-2532
65-66 IMPALA, CAPRICE, BEL AIR***	107-2489
67-70 IMPALA, CAPRICE, BEL AIR***	107-2491
71-72 IMPALA, OLDS, PONT., BUICK***	107-249
73-76 IMPALA, OLDS, 75-76 PONT., BUICK*	107-2492
73-76 IMPALA (WITH STEERING STOP)	107-2494
73-74 PONTIAC, BUICK***	
77-89 IMPALA, OLDS, PONT., BUICK***	107-256
63-82 CORVETTE***	107-2478
64-65 CUTLASS°, 64 CHEVELLE°, M/C° (°USE WITH 1ST DESIGN, 13/16" LINK)***	107-251

\*\*\*THESE ARE JUST A FEW OF THE GENERAL APPLICATIONS; SEE THE CHARTS ON PAGE 46 & 47 FOR MORE APPLICATIONS & TO MAKE SURE YOU GET THE CORRECT ITEM

OEM & RACING BOLTS KITS FOR THE IDLER ARM, THE STEERING BOX, & OTHER SUSPENSION PARTS ARE AVAILABLE ON PAGE 250

NOTE: FOR A CONSTANT STREAM OF NEW PRODUCTS & UP-TO-THE-SECOND PRICING, VISIT [WWW.SOUTHWESTSPEED.COM](http://WWW.SOUTHWESTSPEED.COM)

Place your order at (479) 646-6988, Fax to (479) 646-5939, or visit [www.southwestspeed.com](http://www.southwestspeed.com)

# PITMAN ARMS

★ ALL SWS PITMAN ARMS ARE BRAND NEW & DESIGNED TO REPLACE STOCK ARMS W/ NO MODIFICATIONS  
 ★ IT IS SOMETIMES CONFUSING TRYING TO FIND THE CORRECT PITMAN ARM FOR YOUR STEERING BOX;  
 HOPEFULLY, THESE DESCRIPTIONS & THE PICTURES BELOW WILL HELP

★ THERE ARE 4 MAIN TYPES OF STEERING BOXES USED:

- I. "BIG GM POWER" 700 SERIES SAGINAW BOX, WHICH WAS THE DOMINANT POWER STEERING BOX ON ALMOST ALL GM CARS THROUGH 1977 & ABOUT 1/2 OF ALL GM CARS FROM 1978 TO THE EARLY 90'S; THIS BOX IS DISTINCT FOR ITS SQUARE, 4-BOLT HOUSING COVER; HAS 1 1/8"-32 SPLINE PITMAN ARM SHAFT
- II. "SMALL GM METRIC POWER" 605 SERIES SAGINAW BOX, WHICH BEGAN BEING USED IN 1978 ON ABOUT 1/2 OF ALL GM CARS; THIS BOX IS DISTINCT FOR ITS ROUND, RING RETAINED HOUSING COVER; HAS 1"-32 SPLINE PITMAN ARM SHAFT
- III. "GM MANUAL" 525 SERIES SAGINAW BOX, WHICH IS THE DOMINANT MANUAL STEERING BOX ON ALMOST ALL GM CARS; HAS 1"-32 SPLINE PITMAN ARM SHAFT
- IV. "NEW BIG GM POWER" 600 SERIES DELPHI BOX, WHICH IS A LIGHTER, MODERN REPLACEMENT BOX FOR THE 700 SERIES BIG GM POWER BOX; IT IS ALSO COMMON ON MANY MODERN-DAY TRUCKS; LIKE THE 700 SERIES, IT IS DISTINCT FOR ITS SQUARE, 4-BOLT HOUSING COVER & HAS 1 1/8"-32 SPLINE PITMAN SHAFT

★ ALWAYS CHECK THE CHART ON PAGE 46 & 47 FOR MANY MORE APPLICATIONS & TO MAKE SURE YOU GET THE CORRECT ITEM



"BIG GM POWER" BOX  
700 SERIES



"SMALL GM METRIC  
POWER" BOX  
605 SERIES



"GM MANUAL" BOX  
525 SERIES



"NEW BIG GM  
POWER" BOX  
600 SERIES

#107-164, #107-166, #107-168, #107-170  
5" CENTER-TO-CENTER



#107-1702, #107-1704  
5 1/2" CENTER-TO-CENTER



#107-175, #107-176  
6 7/32" CENTER-TO-CENTER



#107-1457, #107-1459  
5 3/4" CENTER-TO-CENTER



	BIG GM POWER 700/600 SERIES 1 1/8"-32 SPLINE	MANUAL & SMALL POWER 525/605 SERIES 1"-32
<b>APPLICATIONS:</b>		
64-67 CHEVELLE, M/C, 64-65 CUTLASS***	107-170	107-166
68-72 CHEVELLE, 66-72 CUT, 64-72 GTO**	107-168	107-164
73-77 CHEVELLE, 76-77 CUT, 73-77 GTO**	107-1704	107-1702
78-88 CHEVELLE, M/C, CUTLASS, GTO***	107-176	107-175
67 CAMARO***	107-1459	
68-69 CAMARO, 68-70 CHEVY II, NOVA***	107-1459	107-1457
70-72 CAMARO***	107-1626	107-1620
73-74 CAMARO***	107-1626	107-1622
75-81 CAMARO, FIREBIRD, 75-79 NOVA***	107-1626	107-1624
63-67 CHEVY II, NOVA		107-1454
63-64 IMPALA		107-1450
65-66 IMPALA, CAPRICE, BEL AIR***	107-1772	107-1770
67-68 IMPALA, CAPRICE, BEL AIR***	107-1776	107-1774
69-70 IMPALA, CAPRICE, BEL AIR***	107-1780	107-1778
71 IMPALA, CAPRICE, PONTIAC, BUICK***	107-1704	
72-76 IMPALA, CAPRICE, PONT., BUICK***	107-1782	
63-82 CORVETTE***	107-1460	107-1462
64-65 CUTLASS°, 64 CHEVELLE°, M/C° (°USE WITH 1ST DESIGN, 13/16" LINK)***	107-168	107-164

\*\*\*THESE ARE JUST A FEW OF THE GENERAL APPLICATIONS;  
 SEE THE CHARTS ON PAGE 46 & 47 FOR MORE APPLICATIONS & TO MAKE  
 SURE YOU GET THE CORRECT ITEM

## PITMAN ARM NUT & WASHER

★ ALL GM STEERING BOXES HAVE THE SAME  
 THREAD ON THE END OF THE PITMAN SHAFT;  
 THESE SHOULD FIT ANY  
 GM STEERING BOX

**PART #107-1400**



Place your order at (479) 646-6988, Fax to (479) 646-5939, or visit [www.southwestspeed.com](http://www.southwestspeed.com)





# CENTER LINKS, IDLER ARMS, PITMAN ARMS, & TIE RODS

DESCRIPTION	CENTER LINKS		IDLER ARMS		PITMAN ARMS			TIE RODS					
	YEAR	PART #	YEAR	PART #	YEAR	POWER	MANUAL	YEAR	INNERS	YEAR	OUTERS	YEAR	SLEEVES
<b>PONTIAC FIREBIRD &amp; TRANS AM</b>													
			67	107-2486				67-68	105-8492	68	105-8494	67-68	105-8922
			68	107-2488						70-75	105-8588	69-75	105-890
	75-81	107-2291	72-81	107-253	75-81	107-1626	107-1624			76-81	105-861*	76-81	105-890
	82-92	107-2292	82-92	107-2532						*WITH 8 CYL. ENGINE			
										75-79	105-855*	75-79	105-890
										*WITH 6 CYL. ENGINE			
										81	105-855*	81	105-890
										*WITH 6 CYL. ENGINE			
								82-92	105-8612	82-92	105-8614	82-92	105-892
<b>PONTIAC GRAND PRIX</b>													
	69-72	107-227	69-72	107-251				69-70	105-8496			69-70	105-892
	73-77*	107-228*	73-74	107-2494				71-72	105-850			71-72	105-890
	*POWER STEERING		75-77	107-252				73-77	105-854	73-77	105-855	73-77	105-890
	78-87	107-232	78-87	107-256				78-87	105-865	78-87	105-866	78-87	105-892
<b>PONTIAC PARIISIENNE &amp; SAFARI WAGON (87 &amp; UP)</b>													
	83-89	107-2254	83-89	107-256				83-89	105-854	83-89	105-870	83-89	105-890
<b>PONTIAC PHOENIX</b>													
	77-79*	107-2291*	77-79*	107-253*				77-79	105-859*	77-79	105-861*	77-79	105-890
	*POWER STEERING		*POWER STEERING					*DRIVER-SIDE; ALL MANUAL STEERING, AS WELL AS POWER STEERING WITH RALLY SUSPENSION					
	*exc. RALLY SUSPENS.		*exc. RALLY SUSPENS.					77-79 105-860* 77-79 105-861*					
	77-79*	107-229*						*PASSENGER; ALL MANUAL STEERING, AS WELL AS POWER STEERING WITH RALLY SUSPENSION					
	*POWER STEERING									77-79	105-855*	77-79	105-890
	*WITH RALLY SUSPEN.									*POWER STEERING, except RALLY SUSPEN.			
	78-79*	107-229*											
	*MANUAL STEERING												
<b>PONTIAC VENTURA</b>													
	75	107-229	71-72*	107-2488*				71-72	105-8492*	71-72	105-8494*	71-72	105-8922*
	76-77*	107-229*	*exc. WITH 350 ENGINE					*except 350 ENGINES					
	*POWER STEERING		75&77*	107-253*				75-77	105-859*	75-77	105-861*	73-74	105-890
	76-77*	107-2291*	*ALL exc. RALLY SUSP.					*DRIVER-SIDE; ALL except 151 ENGINES					
	*MANUAL STEERING		76*	107-253*				75-77	105-860*	75-77	105-861*	75-77	105-890
			*POWER STEERING					*PASSENGER-SIDE; ALL except 151 ENGINES					
<b>BUICK CENTURY, LUXUS, REGAL, SKYLARK (64-72), &amp; SPECIAL (RWD)</b>													
	64*	107-224*	64*	107-251*	64*	107-168*	107-164*	64-70	105-8496	64-70	105-8497	64-70	105-892
	*1ST DESIGN		*1ST DESIGN, USE		*1ST DESIGN, USE WITH 13/16"			71-72	105-850	71-72	105-851	71-72	105-890
	13/16" DIAMETER		W/ 13/16" DIAM. LINK		DIAMETER CENTER LINK (#107-224)			73-77	105-854	73-77	105-855	73-77	105-890
	64-67*	107-226*	64-67*	107-250*	64-67*	107-170*	107-166*	78-87	105-865*	78-88	105-866*	78-88	105-892*
	*2ND DESIGN		*2ND DESIGN, USE		*2ND DESIGN, USE WITH 7/8"			*exc. 82-87 CENTURY					
	7/8" DIAMETER		W/ 7/8" DIAM. LINK		DIAMETER CENTER LINK (#107-226)			*exc. 82-87 CENTURY					
	68-72	107-227	68-72	107-251	68-72	107-168	107-164						
	73-77	107-228	73-74	107-2494	73-77	107-1704	107-1702						
	78-87*	107-232*	75-77	107-252	78-87	107-176*	107-175						
	*exc. 82-87 CENTURY		78-87*	107-256*	*USED 2 SEPARATE POWER BOXES								
			*exc. 82-87 CENTURY		*THIS FITS 1 1/8" SPLINE "BIG POWER"								
					78-87	107-175*							
					*THIS FITS 1" SPLINE "SMALL POWER"								
<b>BUICK CENTURION, ELECTRA, ESTATE WAGON, INVICTA, LESABRE, &amp; WILDCAT (RWD)</b>													
	71-72	107-225	71-72	107-249	71	107-1704						64-58	105-890
	73-76	107-2252	73-74	107-2494	72-76	107-1782						62-68	105-890
			75-76	107-2492				71-76	105-852	71-76	105-853	71-76	105-890
	77-89	107-2254	77-89	107-256				77-94	105-854	77-94	105-870	77-94	105-890
<b>BUICK APOLLO &amp; SKYLARK (RWD) (75-79)</b>													
	75-77	107-229	73-74	107-2488	73-74	107-1461	107-1457	73-74	105-8492	73-74	105-8494	73-74	105-8922
	78-79*	107-229*	75-79*	107-253*				75-77	105-859*	75-77	105-861	75-77	105-890
	*MANUAL STEERING		*exc. RALLY SUSPENS.					*DRIVER-SIDE					
	78-79*	107-2291*						75-77	105-860*				
	*POWER ST, exc. RALLY							*PASSENGER-SIDE					
								78-79	105-859*	78-79	105-861*	78-79	105-890
								*DRIVER-SIDE; ALL MANUAL STEERING, AS WELL AS POWER STEERING WITH RALLY SUSPENSION					
								78-79	105-860*	78-79	105-861*		
								*PASSENGER; ALL MANUAL STEERING, AS WELL AS POWER STEERING WITH RALLY SUSPENSION					
								78-79	105-855*	78-79	105-855*	78-79	105-890
								*POWER STEERING, except RALLY SUSPEN.					
<b>BUICK RIVIERA</b>													
	71-72	107-225	71-72	107-249	71	107-1704						63-70	105-890
	73-76	107-2252	73-74	107-2494	72-76	107-1782		71-76	105-852	71-76	105-853	71-76	105-890
			75-76	107-2492				77-78	105-854	77-78	105-870	77-78	105-890
	77-78	107-2254	78	107-256								79-85	105-890
<b>FORD MUSTANG &amp; MUSTANG II</b>													
	64-66*	107-2360*	64-66*	107-2580*	64-66	107-1824*	107-1824*	64-66	105-8952*	64-66	105-8950*	64-66	105-890*
	*8 CYL., MANUAL STR.		*8 CYL., except GT-350		*8 CYLINDER ENGINES, except GT350			*8 CYLINDER, MANUAL STEERING					
	64-66*	107-2361*			64-66	107-1826*	107-1826*	64-66	105-8953*	64-66	105-8951*	64-66	105-8930*
	*8 CYL., POWER STR.				*GT350 WITH 8 CYLINDER ENGINE			*8 CYLINDER, POWER, DRIVER-SIDE					
	64-66*	107-2362*			64-66	107-1822*	107-1820*	64-66	105-8952*	64-66	105-8950*	64-66	105-890*
	*6 CYL., MANUAL STR.				*6 CYLINDER ENGINES			*8 CYLINDER, POWER, PASSENGER-SIDE					
	64-66*	107-2363*			67	107-1824*	107-1824*	64-66	105-8945*	64-66	105-8944*	64-66	105-8931*
	*6 CYL., POWER STR.				*FOR 8 CYL. BUILT JAN - APR. '67;			*6 CYLINDER, MANUAL STEERING					
	67-69*	107-2364*	67-70*	107-2582*	THEY HAVE A 1" SECTOR SHAFT			64-66	105-8948*	64-66	105-8946*	64-66	105-8930*
	*MANUAL, exc. Boss 302		*MANUAL STEERING		67 107-1824* 107-1828*			*6 CYLINDER, POWER, DRIVER-SIDE					
	67-69*	107-2365*	67-70*	107-2584*	*FOR 6 CYL. BUILT JAN - APR. '67;			64-66	105-8949*	64-66	105-8947*	64-66	105-890*
	*POWER, exc. Boss 302		*POWER STEERING		THEY HAVE A 1" SECTOR SHAFT			*6 CYLINDER, POWER, PASSENGER-SIDE					
	70*	107-2366*			67-70	107-1832*	107-1830*	67-69	105-8960*	67-69	105-8958*	67-69	105-890*
	*MANUAL, + 69 Boss 302				*FOR ALL BUILT MAY '67 - DEC. '70			*except BOSS					
	70*	107-2367*			THEY HAVE A 1 1/8" SECTOR SHAFT			70	105-8964*	70	105-8962*	70	105-890*
	*POWER, + 69 Boss 302							*ALSO FITS 69 BOSS					
	71-73	107-2368	71-73	107-2586	71-73	107-1836	107-1834	71-73	105-8968	71-73	105-8962	71-73	105-890
<b>FORD THUNDERBIRD</b>													
			67-68	107-2592	68	107-1808							
			69-71	107-2593	69-71	107-1810							
			72-79	107-2594	72-76	107-1812							

Place your order at (479) 646-6988, Fax to (479) 646-5939, or visit [www.southwestspeed.com](http://www.southwestspeed.com)

# INNER TIE ROD ENDS

- ★ ALL SOUTHWEST SPEED TIE ROD ENDS ARE BRAND NEW & DESIGNED TO REPLACE STOCK ENDS WITH NO MODIFICATIONS
- ★ NECESSARY HARDWARE (NUTS, COTTER PINS, GREASE FITTINGS, BOOTS, ETC) IS INCLUDED
- ★ ALWAYS CHECK THE CHART ON PAGE 46 & 47 FOR MANY MORE APPLICATIONS & TO MAKE SURE YOU GET THE CORRECT ITEM

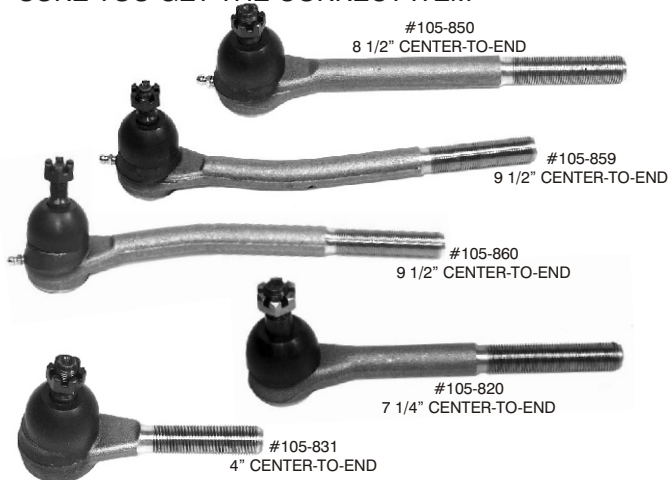

DESCRIPTION	PART #
64-70 CHEVELLE, M/C, CUT, 64-65 GTO***	105-8496
71-72 CHEVELLE, M/C, CUTLASS, GTO***	105-850
73-77 CHEVELLE, M/C, CUTLASS, GTO***	105-854
78-88 CHEVELLE, M/C, CUTLASS, GTO***	105-865
67-69 CAMARO, 67-68 FIRE, 68-74 NOVA**	105-8492
70-74 CAMARO (DRIVERSIDE)***	105-8584
70-74 CAMARO (PASSENGER)***	105-8586
75-81 CAMARO, NOVA(DRIVERSIDE)***	105-859
75-81 CAMARO, NOVA (PASSENGER)***	105-860
82-92 CAMARO, FIREBIRD, TRANS AM***	105-8612
65-68 IMPALA, CAPRICE, BEL AIR***	105-820
69-70 IMPALA, CAPRICE, BEL AIR***	105-8518
71-76 IMPALA, OLDS, PONTIAC, BUICK***	105-852
77-91 IMPALA, OLDS, PONTIAC, BUICK***	105-854
63-82 CORVETTE***	105-831
66-67 GTO, LEMANS***	105-8499
68-70 GTO, LEMANS***	105-8496
72-78 RAM CHARGER***	105-878

\*\*\*THESE ARE JUST A FEW OF THE GENERAL APPLICATIONS; SEE THE CHARTS ON PAGE 46 & 47 FOR MORE APPLICATIONS & TO MAKE SURE YOU GET THE CORRECT ITEM

# TIE ROD END ADJUSTING SLEEVES

DESCRIPTION	PART #
71-77 CHEVELLE, MONTE CARLO, CUTLASS, GTO, 70-81 CAMARO, 69-81 FIREBIRD, TRANS AM***	105-890
71-94 IMPALA, CAPRICE, OLDS, BUICK, 71-77 PONTIAC, 64-73 MUSTANG & MUSTANG II (SEE CHART)	105-892
64-70 & 78-88 CHEVELLE, MONTE CARLO, CUTLASS, 64-70 & 78-81 GTO, 82-92 CAMARO***	105-892
82-92 FIREBIRD, TRANS AM, 63-67 CHEVY II, NOVA, 82-86 PONTIAC BONNEVILLE, ETC.	105-892
67-69 CAMARO, 67-68 FIREBIRD, TRANS AM, 65-70 IMPALA, CAPRICE, 68-74 CHEVY II, NOVA***	105-8922
63-82 CORVETTE***	105-8798
64-66 MUSTANG & MUSTANG II (SEE THE CHARTS ON PAGE 46 & 47)***	105-8930
64-66 MUSTANG & MUSTANG II (SEE THE CHARTS ON PAGE 46 & 47)***	105-8931

\*\*\*THESE ARE JUST A FEW OF THE GENERAL APPLICATIONS; SEE THE CHARTS ON PAGE 46 & 47 FOR MORE APPLICATIONS & TO MAKE SURE YOU GET THE CORRECT ITEM

# OUTER TIE ROD ENDS

- ★ ALL SOUTHWEST SPEED TIE ROD ENDS ARE BRAND NEW & DESIGNED TO REPLACE STOCK ENDS WITH NO MODIFICATIONS
- ★ NECESSARY HARDWARE (NUTS, COTTER PINS, GREASE FITTINGS, BOOTS, ETC) IS INCLUDED
- ★ ALWAYS CHECK THE CHART ON PAGE 46 & 47 FOR MANY MORE APPLICATIONS & TO MAKE SURE YOU GET THE CORRECT ITEM

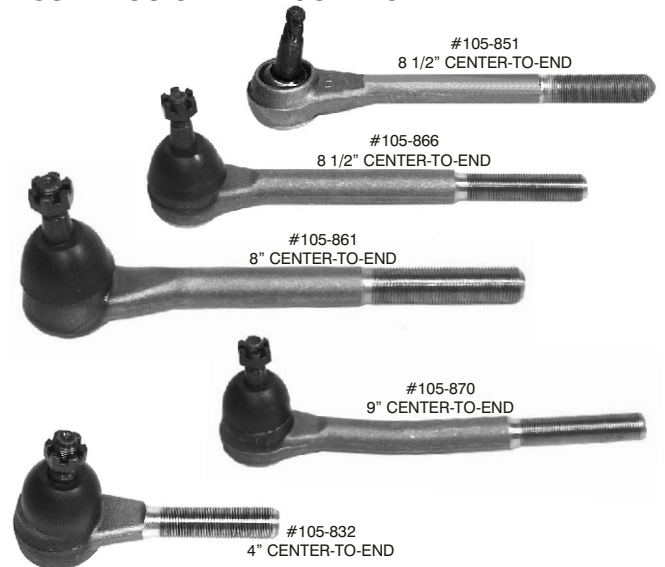

DESCRIPTION	PART #
64-70 CHEVELLE, M/C, CUTLASS, GTO***	105-8497
71-72 CHEVELLE, M/C, CUTLASS, GTO***	105-851
73-77 CHEVELLE, M/C, CUTLASS, GTO***	105-855
78-88 CHEVELLE, M/C, CUTLASS, GTO***	105-866
67-69 CAMARO, 68 FIREBIRD, 68-74 NOVA*	105-8494
70-74 CAMARO, 70-75 FIREBIRD, TRANS**	105-8588
75-81 CAMARO, 76-81 FIRE, 75-79 NOVA**	105-861
82-92 CAMARO, FIREBIRD, TRANS AM***	105-8614
65-68 IMPALA, CAPRICE, BEL AIR***	105-8517
69-70 IMPALA, CAPRICE, BEL AIR***	105-8519
71-76 IMPALA, OLDS, PONTIAC, BUICK***	105-853
77-93 IMPALA, OLDS, PONTIAC, BUICK***	105-870
63-82 CORVETTE***	105-832

\*\*\*THESE ARE JUST A FEW OF THE GENERAL APPLICATIONS; SEE THE CHARTS ON PAGE 46 & 47 FOR MORE APPLICATIONS & TO MAKE SURE YOU GET THE CORRECT ITEM

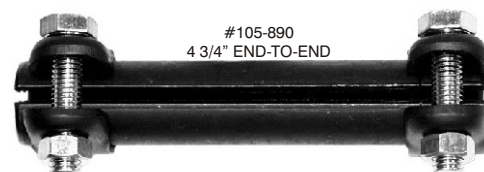

Place your order at (479) 646-6988, Fax to (479) 646-5939, or visit [www.southwestspeed.com](http://www.southwestspeed.com)



# RACING TIE ROD ENDS

- ★ THESE ARE THE MOST POPULAR TIE ROD ENDS ON MODIFIEDS & MANY OTHER CLASSES
- ★ ALSO WORK GREAT FOR RACK & PINIONS WITH TAPERED EYES
- ★ ALL COMPONENTS ARE BRAND NEW
- ★ ALL NECESSARY HARDWARE IS INCLUDED
- ★ \*\*#105-8311, #105-8321, & #105-8201 ARE EXCLUSIVELY DESIGNED BY SOUTHWEST SPEED WITH THE GREASE FITTING IN THE END (INSTEAD OF THE BOTTOM) WHICH GIVES EXTRA CLEARANCE AWAY FROM THE CROSS-MEMBER
- ★ AVAILABLE WITH 5/8"-18 LEFT & RIGHT HAND THREADS IN BOTH 4" & 7 1/4" LONG DESIGNS (MEASURED CENTER OF PIN TO END OF THREADS)

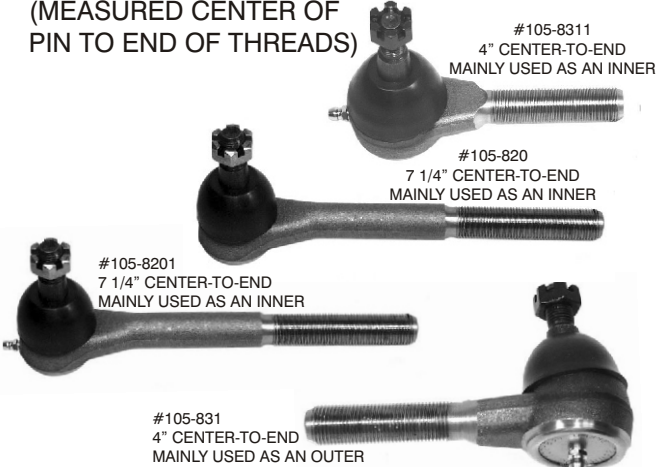

MAINLY USED AS INNER TIE ROD ENDS	PART #
4" LONG, 5/8"-18 LEFT, MOD. END**	105-8311
4" LONG, 5/8"-18 RIGHT, MOD. END**	105-8321
7 1/4" LONG, 5/8"-18 LEFT, MOD. END	105-819
7 1/4" LONG, 5/8"-18 RIGHT, MOD. END	105-820
7 1/4" LONG, 5/8"-18 RIGHT, MOD. END**	105-8201
MAINLY USED AS OUTER TIE ROD ENDS	PART #
4" LONG, 5/8"-18 LEFT, MOD. END	105-831
4" LONG, 5/8"-18 RIGHT, MOD. END	105-832

# TIE ROD ADJUSTERS

- ★ USED FOR EASY ADJUSTMENT OF TIE RODS; STEEL OR ALUMINUM; 5/8" OR 3/4", LEFT OR RIGHT THREAD



APPLICATION	BUILD	THREAD		PART #
		MALE	FEMALE	
		SIZE	THREAD	
TIE RODS	STEEL	3/8"	LEFT RIGHT	500-9906
TIE RODS	STEEL	1/2"	LEFT RIGHT	500-9908
TIE RODS	STEEL	5/8"	RIGHT LEFT	500-9999
TIE RODS	STEEL	3/4"	RIGHT LEFT	501-003
TIE RODS	STEEL	5/8"	LEFT RIGHT	501-000
TIE RODS	STEEL	3/4"	LEFT RIGHT	501-002
TIE RODS	ALUM.	5/8"	LEFT RIGHT	500-999
TIE RODS	ALUM.	3/4"	LEFT RIGHT	501-001

# SWAY BAR ADJUSTING SLEEVE

- ★ THREADED LEFT & RIGHT
- ★ 1/2"-20" THREAD x 2 1/2" LONG HEX BODY



# BUMP STEER KITS SPACER KIT

- ★ TAPERED DESIGN
- ★ 2" BODY COMES WITH .100", .200", & .300" SPACERS
- ★ USED WITH 5/8" ROD END



PART #105-084

# GRADE 8 BOLT FOR SPACER KIT

- ★ COMES WITH JAM NUT
- ★ 5/8"-18 THREADS
- ★ 4 1/2" LONG
- ★ USED W/ 5/8" ROD END

PART #105-086

# STUD KITS

- ★ TAPERED DESIGN
- ★ ELIMINATES THE NEED TO DRILL THE SPINDLE
- ★ SOLD COMPLETE W/ NUTS & SPACERS

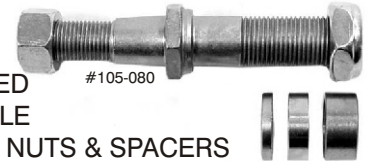

DESCRIPTION	PART #
METRIC SPINDLE, SHORT STUD	105-080
PINTO SPINDLE, LONG STUD	105-082

# BOLTS & SPACERS

- ★ USE WITH 5/8"-18 ROD ENDS
- ★ ADJUSTS BUMP STEER
- ★ SHIMS PRICED EACH & SOLD IN BAGS OF 10

DESCRIPTION	PART #
.050" BUMP STEER SHIM	105-064
.100" BUMP STEER SHIM	105-066
.150" BUMP STEER SHIM	105-067
.200" BUMP STEER SHIM	105-068
.250" BUMP STEER SHIM	105-069
.300" BUMP STEER SHIM	105-070
.350" BUMP STEER SHIM	105-072
5/8" x 3" SPINDLE BOLT (EACH), GRADE 8	105-060
5/8" x 4 1/2" BOLT & NUT (EACH), GRADE 8	105-086

# STABILIZER/SWAY BARS



SWAY BAR KIT COMES WITH 1 SWAY BAR, 2 STEEL THREADED EYES, 4 JAM NUTS, AND 1 LOWER BOLT, NUT, & WASHER.

- ★ MANDREL BENT, TUBULAR BARS
- ★ HEAT-TREATED & SURFACE-STRESS RELIEVED
- ★ WILL FIT, AMONG OTHERS, RACING 1970-81 CAMARO'S & MOST TUBULAR SUB-FRAMES

DESCRIPTION	ENTIRE KIT	BAR ONLY
1" DIAMETER, 160 LB.	104-940	104-900
1 1/16" DIAMETER, 192 LB.	104-941	104-901
1 1/8" DIAMETER, 225 LB.	104-942	104-902
1 1/4" DIAMETER, 310 LB.	104-944	104-904

DESCRIPTION	PART #
LARGE THREADED EYE ONLY, STEEL	104-910
LARGE THREADED EYE ONLY, ALUMINUM	104-911
SWAY BAR FRAME TUBE, WELD-IN	104-907
JAM NUT ONLY, 7/8" COARSE	104-914
LOWER BOLT, NUT, & WASHERS	104-915

Place your order at (479) 646-6988, Fax to (479) 646-5939, or visit [www.southwestspeed.com](http://www.southwestspeed.com)

# THREADED TUBES

## 6061-T6 ALUMINUM

- ★ BRAND NEW MATERIAL
- ★ WRENCH FLATS ON LEFT HAND END
- ★ THREADED LEFT & RIGHT,  
1/2", 5/8", OR 3/4"



NOTE: 5/8" ROD END WITH JAM NUT ADDS 1 3/8" PER SIDE, WHILE 3/4" ROD END WITH JAM NUT ADDS 1 1/2" PER SIDE.

# THREADED TUBES

## ROTO-SWEDGED STEEL

- ★ DEEP KNURL FOR EASY ADJUSTMENT
- ★ BRIGHT ZINC PLATING
- ★ THREADED LEFT & RIGHT,  
5/8" OR 3/4"



NOTE: WE ARE ALWAYS DEVELOPING NEW STYLES & SIZES OF THREADED TUBES; MAKE SURE TO CHECK [www.southwestspeed.com](http://www.southwestspeed.com)

LENGTH	1/2 x 3/4 O.D.	5/8 x 7/8 O.D.	3/4 x 1 O.D.
3"	500-953	501-053	501-153
4"	500-954	501-054	501-154
5"	500-955	501-055	501-155
6"	500-956	501-056	501-156
7"	500-957	501-057	501-157
8"	500-958	501-058	501-158
9"	500-959	501-059	501-159
10"	500-960	501-060	501-160
11"	500-961	501-061	501-161
12"	500-962	501-062	501-162
13"	500-963	501-063	501-163
14"	500-964	501-064	501-164
15"	500-965	501-065	501-165
16"		501-066	501-166
17"		501-067	501-167
18"		501-068	501-168
19"		501-069	501-169
20"		501-070	501-170
21"		501-071	501-171
22"		501-072	501-172
23"		501-073	501-173
24"		501-074	501-174
25"		501-075	501-175
26"		501-076	501-176
27"		501-077	501-177
28"		501-078	501-178
29"		501-079	501-179
30"		501-080	501-180
31"			501-181
32"			501-182
33"			501-183
34"			501-184
35"			501-185
36"			501-186
37"			501-187
38"			501-188
39"			501-189
40"			501-190
41"			501-191
42"			501-192
43"			501-193
44"			501-194
45"			501-195
46"			501-196
47"			501-197
48"			501-198
49"			501-199

LENGTH	5/8 x 7/8 O.D.	3/4 x 1 O.D.
3"	501-0031	501-103
4"	501-004	501-104
5"	501-005	501-105
6"	501-006	501-106
7"	501-007	501-107
8"	501-008	501-108
9"	501-009	501-109
10"	501-010	501-110
11"	501-011	501-111
12"	501-012	501-112
13"	501-013	501-113
14"	501-014	501-114
15"	501-015	501-115
16"	501-016	501-116
17"	501-017	501-117
18"	501-018	501-118
19"	501-019	501-119
20"	501-020	501-120
21"	501-021	501-121
22"	501-022	501-122
23"	501-023	501-123
24"	501-024	501-124
25"	501-025	501-125
26"	501-026	501-126
27"	501-027	501-127
28"	501-028	501-128
29"	501-029	501-129
30"		501-130
31"		501-131
32"		501-132
33"		501-133
34"		501-134
35"		501-135
36"		501-136
37"		501-137
38"		501-138
39"		501-139
40"		501-140
41"		501-141
42"		501-142
43"		501-143
44"		501-144
45"		501-145
46"		501-146
47"		501-147
48"		501-148
49"		501-149

Place your order at (479) 646-6988, Fax to (479) 646-5939, or visit [www.southwestspeed.com](http://www.southwestspeed.com)

## ALUMINUM ROD ENDS

- ★PRECISION MACHINED, 7075-T6 ALLOY BODY, HIGH CARBON STEEL BALLS
- ★LEFT OR RIGHT FINE THREADS



THREAD SIZE	BORE SIZE	RIGHT MALE	LEFT MALE
10-32	10-32	103-1038	103-1138
1/4" -28	1/4"	103-104	103-114
5/16" -24	5/16"	103-105	103-115
3/8" -24	3/8"	103-106	103-116
7/16" -20	7/16"	103-107	103-117
1/2" -20	1/2"	103-108	103-118
5/8" -18	1/2"	103-109	103-119
5/8" -18	5/8"	103-110	103-120
3/4" -16	5/8"	103-111	103-121
3/4" -16	3/4"	103-112	103-122
3/4" -16	.757"	103-113	

## CHROMEMOLY ROD ENDS

- ★AIRCRAFT GRADE; PRECISION MACHINED; NITRILE LINER; HIGH CARBON STEEL BALLS



THREAD SIZE	BORE SIZE	RIGHT MALE	LEFT MALE
7/16" -20	7/16"	103-207	103-217
1/2" -20	1/2"	103-208	103-218
5/8" -18	5/8"	103-210	103-220
3/4" -16	3/4"	103-212	103-222

## SOLID ROD ENDS

- ★PRECISION MACHINED
- ★STRUT MOUNT ON STUD TYPE LOWERS



THREAD SIZE	BORE SIZE	RIGHT MALE
5/8" -18	5/8"	103-310
3/4" -16	5/8"	103-311
3/4" -16	3/4"	103-312

## STUDED ROD ENDS

- ★PRECISION MACHINED
- ★HIGH CARBON STEEL BALLS
- ★RIGHT FINE THREADS



THREAD SIZE	STUD SIZE	RIGHT MALE	RIGHT FEMALE
1/4" -28	1/4" -28	103-044	103-064
5/16" -24	5/16" -24	103-045	103-065

## RUBBER BUSHING TRAILING ARM MOUNTS

- ★2 3/8" WIDE, 3/4" BOLT HOLE
- ★LEFT OR RIGHT 3/4" FINE THREAD



DESCRIPTION	PART #
TRAILING ARM MOUNT, LH THREAD	500-901
TRAILING ARM MOUNT, RH THREAD	500-903

## STEEL ROD ENDS

- ★HIGH CARBON STEEL BALLS
- ★ROLLED LEFT OR RIGHT HAND FINE THREADS



THREAD SIZE	BORE SIZE	MALE RIGHT THRD	MALE LEFT THRD	FEMALE RIGHT THRD	FEMALE LEFT THRD
10-32	.190	103-0038	103-0138		103-033
1/4" -28	1/4"	103-004	103-014	103-024	103-034
5/16" -24	5/16"	103-005	103-015	103-025	103-035
3/8" -24	3/8"	103-006	103-016	103-026	103-036
7/16" -20	7/16"	103-007	103-017	103-027	103-037
1/2" -20	1/2"	103-008	103-018	103-028	103-038
5/8" -18	1/2"	103-009	103-019		
5/8" -18	5/8"	103-010	103-020	103-030	103-040
3/4" -16	5/8"	103-011	103-021		
3/4" -16	3/4"	103-012	103-022	103-032	103-042
3/4" -16	.757"	103-013			
1 1/4" -12	1"	103-0135	103-0235		
1 1/4" -12	1 1/4"	103-0136	103-0236		

## GUN-DRILLED STEEL ROD ENDS

- ★EXCLUSIVE DESIGN ELIMINATES UNNECESSARY WEIGHT; PRECISION MACHINED; HIGH CARBON BALLS



THREAD SIZE	BORE SIZE	RIGHT MALE	LEFT MALE
5/8" -18	5/8"	103-0101	103-0201
3/4" -16	3/4"	103-0121	103-0221

## STEERING ROD ENDS

- ★OVERSIZED TO FIT 3/4" STEERING SHAFTS

THREAD	BORE	ALUMINUM	STEEL
3/4" -16R	.757	103-113	103-013

## JAM NUTS

- ★SOLD IN PACKS OF 10; PLATED STEEL, BUT WE HAVE ALUMINUM AVAILABLE



	THREAD SIZE	RIGHT	LEFT	NYLOCK RIGHT
FINE	10-32	102-9336	102-9436	
	1/4" -28	102-934	102-944	102-9339
	5/16" -24	102-935	102-945	102-9349
	3/8" -24	102-936	102-946	102-9359
	7/16" -20	102-9369	102-9469	102-9367
	1/2" -20	102-938	102-948	102-937
	5/8" -18	102-940	102-950	102-939
	5/8" -18*	102-9401	102-9501	
	3/4" -16	102-942	102-952	102-941
	3/4" -16*	102-9421	102-9521	
7/8" -18	102-9431			
COARSE	1/4" -20	102-9314		102-9239
	5/16" -18	102-9315		102-9249
	3/8" -16	102-9316		102-9259
	1/2" -13	102-9318		102-927
	5/8" -11	102-9320		102-929
	3/4" -10	102-943		102-931

\*INDICATES SMALLER THAN NORMAL HEX SIZE FOR LESS WEIGHT

Place your order at (479) 646-6988, Fax to (479) 646-5939, or visit [www.southwestspeed.com](http://www.southwestspeed.com)



# SOUTHWEST SPEED CAST IRON POWER STEERING PUMPS

- ★CAST IRON PUMPS WITH ALUMINUM, HARD ANODIZED V-BELT OR SERPENTINE PULLEYS
- ★-10AN INLET, -6AN OUTLET
- ★HIGH PRESSURE, 1250 PSI
- ★PUMPS 2.25 GALLONS PER MINUTE



DESCRIPTION	PART #
13.5CC PUMP W/ 6" V-BELT PULLEY	150-001
13.5CC PUMP W/ 4.2" SERPENTINE PULLEY	150-002
13.5CC PUMP ONLY - NO PULLEY	150-000
6" V-BELT PULLEY ONLY	149-999
4.2" SERPENTINE PULLEY ONLY	149-9992

# PUMPS WITH ATTACHED RESERVOIRS

- ★ALUMINUM & CAST IRON PUMPS WITH ALUMINUM, HARD ANODIZED V-DRIVE PULLEYS & NYLON RESERVOIRS
- ★-6 AN INLET, -6 AN OUTLET
- ★AVAILABLE IN 1100 & 1250 PSI



DESCRIPTION	PART #
ALUM PUMP & TANK, 1250 PSI	149-165
STEEL PUMP & TANK, 1100 PSI	149-173
STEEL PUMP & TANK, 1250 PSI	149-175
COMPLETE HOSE KIT	150-220
6" V-BELT PULLEY ONLY, PRESS-ON	149-159
TANK & CAP WITH DIPSTICK ONLY	149-156
CAP & DIPSTICK ONLY	110-075
*1250 PSI PUMPS ARE RECOMMENDED WITH VEHICLES EQUIPPED WITH STEERING QUICKKNERS	

# REMOTE P.S. RESERVOIRS

- ★EACH ALUMINUM TANK INCLUDES A MOUNTING BRACKET AND FEATURES A -10 AN OUTLET FITTING & A -6 AN NON-FOAMING INLET FITTING
- ★THE SQUARE RESERVOIR HAS INTERNAL BAFFLING & THE MOUNTING BRACKET IS BUILT-ON TO MOUNT TO THE FIREWALL



DESCRIPTION	PART #
ROUND TANK, LIGHTWEIGHT ECONOMY	150-198
ROUND TANK, SPUN ALUMINUM	150-201
SQUARE TANK	150-210
REPLACEMENT LID ONLY	110-086

# SOUTHWEST SPEED CAST IRON SBC P.S. PUMP KITS

- ★EACH KIT INCLUDES A CAST IRON PUMP WITH ALUMINUM PULLEY, LIGHTWEIGHT ROUND REMOTE RESERVOIR, & SBC MOUNTING BRACKET
- ★HEAD MOUNT OR BLOCK MOUNT BRACKET
- ★V-BELT OR SERPENTINE PULLEY



SWS POWER STEERING PUMP KITS				
PUMP	TANK	PULLEY	BRACKET	PART #
STEEL	REMOTE	V-BELT	HEAD	150-103
STEEL	REMOTE	V-BELT	BLOCK	150-113
STEEL	REMOTE	SERPENTINE	HEAD	150-104
STEEL	REMOTE	SERPENTINE	BLOCK	150-114

# P.S. PUMP BRACKETS SMALL BLOCK CHEVY

- ★ADJUSTABLE DESIGNS
- ★6061-T6 ALUMINUM CONSTRUCTION
- ★SOLD COMPLETE W/ BOLTS, NUTS, & WASHERS
- ★AVAILABLE TO BOLT TO THE LEFT CYLINDER HEAD OR TO THE LEFT FRONT OF THE BLOCK

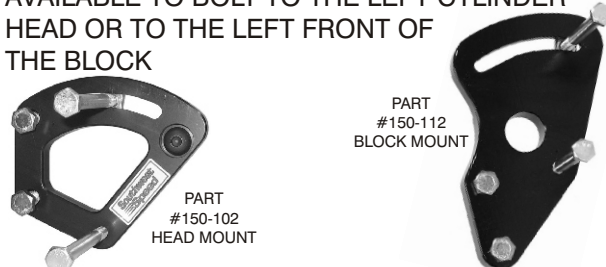

DESCRIPTION	PART #
CHEVY HEAD MOUNT	150-102
CHEVY BLOCK MOUNT	150-112

# FORD

- ★2 DIFFERENT DESIGNS AVAILABLE TO FIT ALMOST EVERY FORD HEAD
- ★CHECK THE DIMENSIONS TO DETERMINE WHICH BRACKET WILL FIT YOUR HEAD

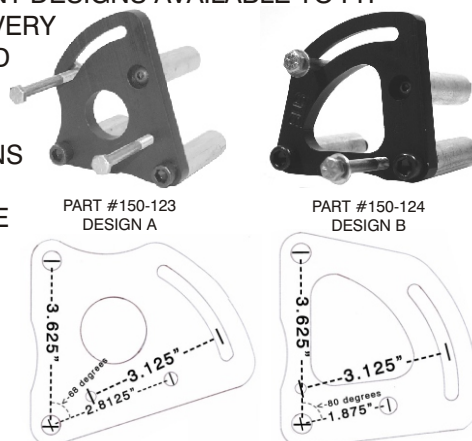

DESCRIPTION	PART #
FORD HEAD MOUNT, DESIGN A	150-123
FORD HEAD MOUNT, DESIGN B	150-124

Place your order at (479) 646-6988, Fax to (479) 646-5939, or visit [www.southwestspeed.com](http://www.southwestspeed.com)

# KRC ALUMINUM & CAST IRON POWER STEERING PUMPS

★ALUMINUM PUMPS & CAST IRON PUMPS BOTH WITH ALUMINUM V-BELT OR SERPENTINE PULLEYS

★-10AN INLET & -6AN OUTLET ON PUMPS WITHOUT A TANK

★PUMPS WITH A TANK HAVE -6AN INLET ON THE TANK & -6AN OUTLET

★THE FLOW CAN BE ADJUSTED WITH THE CHANGEABLE FLOW VALVES

KRC ALUMINUM POWER STEERING PUMPS	
DESCRIPTION	PART #
9.6CC PUMP W/ 6" V-BELT PULLEY	KRC 63201 000
9.6CC PUMP W/ 6" V-BELT PULLEY & BOLT-ON TANK	KRC 63201 100
9.6CC PUMP W/ 4.2" SERPENTINE PULLEY	KRC 63202 000
9.6CC PUMP W/ 4.2" SERPENTINE PULLEY & BOLT-ON TANK	KRC 63202 100
9.6CC PUMP ONLY - NO PULLEY - NO TANK	KRC 63200 000
9.6CC PUMP W/ BOLT-ON TANK - NO PULLEY	KRC 63200 100
6" V-BELT PULLEY ONLY	KRC 20011 000
4.2" SERPENTINE PULLEY ONLY	KRC 20015 000
BOLT-ON TANK ONLY, -6 INLET, -10 OUTLET, 8 OZ.	KRC 60312 000
REPLACEMENT -6 AN FLOW VALVE, 1.05 GPM, ID-4	KRC 21304
REPLACEMENT -6 AN FLOW VALVE, 1.32 GPM, ID-5	KRC 21305
REPLACEMENT -6 AN FLOW VALVE, 1.58 GPM, ID-6	KRC 21306
REPLACEMENT -6 AN FLOW VALVE, 1.84 GPM, ID-7	KRC 21307
REPLACEMENT -6 AN FLOW VALVE, 2.11 GPM, STANDARD	KRC 21308
REPLACEMENT -6 AN FLOW VALVE, 2.37 GPM, ID-B	KRC 21309
REPLACEMENT -6 AN FLOW VALVE, 2.64 GPM, ID-C	KRC 21310
REPLACEMENT -6 AN FLOW VALVE, 2.90 GPM, ID-D	KRC 21311
REPLACEMENT -6 AN FLOW VALVE, 3.17 GPM, ID-E	KRC 21312
INLET FITTING, -10 AN MALE	KRC 21200



KRC 63201 000



KRC 63202 100



KRC 50020 000



KRC 50010 100

KRC CAST IRON POWER STEERING PUMPS	
DESCRIPTION	PART #
13.5CC PUMP W/6" V-BELT PULLEY	KRC 50010 000
13.5CC PUMP W/6" V-BELT PULLEY & BOLT-ON TANK	KRC 50010 100
13.5CC PUMP W/4.2" SERPENTINE PULLEY	KRC 50020 000
13.5CC PUMP W/4.2" SERPENTINE PULLEY & BOLT-ON TANK	KRC 50020 100
13.5CC PUMP ONLY - NO PULLEY - NO TANK	KRC 50000 000
13.5CC PUMP W/ BOLT-ON TANK - NO PULLEY	KRC 50000 100
6" V-BELT PULLEY ONLY	KRC 50100 000
4.2" SERPENTINE PULLEY ONLY	KRC 50120 000
BOLT-ON TANK ONLY, -6 INLET, -10 OUTLET, 8 OZ.	KRC 91312 000
REPLACEMENT -6 AN FLOW VALVE, 1.50 GPM, ID-4	KRC 51304
REPLACEMENT -6 AN FLOW VALVE, 1.75 GPM, ID-5	KRC 51305
REPLACEMENT -6 AN FLOW VALVE, 2.00 GPM, ID-6	KRC 51306
REPLACEMENT -6 AN FLOW VALVE, 2.25 GPM, ID-7	KRC 51307
REPLACEMENT -6 AN FLOW VALVE, 2.50 GPM, STANDARD	KRC 51308
REPLACEMENT -6 AN FLOW VALVE, 2.80 GPM, ID-B	KRC 51309
REPLACEMENT -6 AN FLOW VALVE, 3.10 GPM, ID-C	KRC 51310
REPLACEMENT -6 AN FLOW VALVE, 3.45 GPM, ID-D	KRC 51311
REPLACEMENT -6 AN FLOW VALVE, 3.70 GPM, ID-E	KRC 51312
INLET FITTING, -10 AN MALE	KRC 21200

## KRC P.S. PUMP BRACKETS



KRC 31410 000



KRC 31415 000



KRC 30026 000



KRC 31610 000



KRC 31515 000



KRC 31100 000

DESCRIPTION	PART #
SMALL BLOCK CHEVY, LEFT HEAD	KRC 31410 000
SMALL BLOCK CHEVY, LEFT BLOCK	KRC 31415 000
BIG BLOCK CHEVY, LEFT HEAD	KRC 30020 000
BIG BLOCK CHEVY, LOWER LEFT BLOCK	KRC 30026 000
FORD 260, 289, & 302, LEFT HEAD	KRC 31610 000
FORD 351-400, LEFT HEAD	KRC 31620 000
DODGE 360, BLOCK	KRC 31515 000
QUICKCHANGE BRKT, FITS LH & RH TUBE	KRC 30500 000
UNIVERSAL BRKT, TRIM-TO-FIT, 6" X 6"	KRC 31100 000

\*EACH BRACKET COMES WITH NECESSARY HARDWARE

## KRC SERPENTINE PULLEY KITS

★PRO SERIES KITS INCLUDE SERPENTINE WATER PUMP

PULLEY, CRANK PULLEY, CRANK ADAPTER, BOLTS, & BELT\*\*\*

★SETS MOTOR UP FOR USE WITH SERPENTINE P.S. PULLEY

DESCRIPTION	PART #
SBC KIT, HEAD MOUNT PUMP, 30% REDUCTION	KRC 37400 000
SBC KIT, BLOCK MOUNT PUMP, 30% REDUCTION	KRC 37401 000
SBC KIT, HEAD MOUNT PUMP, 15% REDUCTION	KRC 37410 001
SBC KIT, BLOCK MOUNT PUMP, 15% REDUCTION	KRC 37411 001
SBC KIT, HEAD MOUNT PUMP, 1 TO 1	KRC 37420 000
SBC KIT, BLOCK MOUNT PUMP, 1 TO 1	KRC 37421 000
FORD KIT, 3 BOLT BALANCER, 30% REDUCT.***	KRC 37600 000
FORD KIT, 4 BOLT BALANCER, 30% REDUCT.***	KRC 37605 000
FORD KIT, 3 BOLT BALANCER, 15% REDUCT.***	KRC 37610 000
FORD KIT, 4 BOLT BALANCER, 15% REDUCT.***	KRC 37615 000
FORD KIT, 3 BOLT BALANCER, 1 TO 1***	KRC 37620 000
FORD KIT, 4 BOLT BALANCER, 1 TO 1***	KRC 37625 000
DODGE KIT, BLOCK MOUNT, 30% REDUCTION	KRC 37501 000
DODGE KIT, BLOCK MOUNT, 15% REDUCTION	KRC 37511 000
DODGE KIT, BLOCK MOUNT, 1 TO 1	KRC 37521 000

\*\*\*FORD KITS ARE HEAD MOUNT & DO NOT INCLUDE THE BELT



KRC 37400 000



KRC 37610 000

## KRC BOLT-ON RESERVOIR

★WILL BOLT ON EXISTING KRC ALUMINUM & CAST IRON PUMPS

★2 BOLT MOUNTING FLANGE, -6AN INLET, -10AN OUTLET, & 8 OZ. CAPACITY

PART #KRC 91312 000



Place your order at (479) 646-6988, Fax to (479) 646-5939, or visit [www.southwestspeed.com](http://www.southwestspeed.com)



# KRC ALUMINUM & CAST IRON POWER STEERING PUMP KITS

★ EACH KRC POWER STEERING PUMP KIT INCLUDES PUMP, TANK, & BRACKET

★ AVAILABLE WITH THE ALUMINUM PUMP OR THE CAST IRON PUMP FOR SMALL BLOCK CHEVY, FORD 302, & FORD 351

★ AVAILABLE WITH EITHER THE REMOTE TANK OR THE BOLT-ON TANK

★ PUMPS WITH A REMOTE TANK HAVE -10AN INLET & -6AN OUTLET

★ PUMPS WITH A BOLT-ON TANK HAVE -6AN INLET ON THE TANK & -6AN OUTLET

#KRC 29010-H  
SBC HEAD MOUNT  
WITH V-BELT PULLEY  
& REMOTE TANK

KRC ALUMINUM POWER STEERING PUMP KITS					
MOTOR	PUMP	TANK	PULLEY	BRACKET	PART #
SBC	ALUMINUM	REMOTE	V-BELT	HEAD	KRC 29010-H
SBC	ALUMINUM	REMOTE	V-BELT	BLOCK	KRC 29010-B
SBC	ALUMINUM	REMOTE	SERPENTINE	HEAD	KRC 29020-H
SBC	ALUMINUM	REMOTE	SERPENTINE	BLOCK	KRC 29020-B
SBC	ALUMINUM	BOLT-ON	V-BELT	HEAD	KRC 28010 110
SBC	ALUMINUM	BOLT-ON	V-BELT	BLOCK	KRC 28010 115
SBC	ALUMINUM	BOLT-ON	SERPENTINE	HEAD	KRC 28020 110
SBC	ALUMINUM	BOLT-ON	SERPENTINE	BLOCK	KRC 28020 115
FORD 302	ALUMINUM	BOLT-ON	V-BELT	HEAD	KRC 28610 111
FORD 302	ALUMINUM	BOLT-ON	SERPENTINE	HEAD	KRC 28620 111
FORD 351	ALUMINUM	BOLT-ON	V-BELT	HEAD	KRC 28610 121
FORD 351	ALUMINUM	BOLT-ON	SERPENTINE	HEAD	KRC 28620 121

KRC CAST IRON POWER STEERING PUMP KITS					
MOTOR	PUMP	TANK	PULLEY	BRACKET	PART #
SBC	STEEL	REMOTE	V-BELT	HEAD	KRC 59010-H
SBC	STEEL	REMOTE	V-BELT	BLOCK	KRC 59010-B
SBC	STEEL	REMOTE	SERPENTINE	HEAD	KRC 59020-H
SBC	STEEL	REMOTE	SERPENTINE	BLOCK	KRC 59020-B
SBC	STEEL	BOLT-ON	V-BELT	HEAD	KRC 58010 110
SBC	STEEL	BOLT-ON	V-BELT	BLOCK	KRC 58010 115
SBC	STEEL	BOLT-ON	SERPENTINE	HEAD	KRC 58020 110
SBC	STEEL	BOLT-ON	SERPENTINE	BLOCK	KRC 58020 115
FORD 302	STEEL	BOLT-ON	V-BELT	HEAD	KRC 58610 111
FORD 302	STEEL	BOLT-ON	SERPENTINE	HEAD	KRC 58620 111
FORD 351	STEEL	BOLT-ON	V-BELT	HEAD	KRC 58610 121
FORD 351	STEEL	BOLT-ON	SERPENTINE	HEAD	KRC 58620 121



#KRC 28020 115  
SBC BLOCK MOUNT  
WITH SERPENTINE  
PULLEY &  
BOLT-ON TANK



#KRC 58620 111  
FORD 302 HEAD MOUNT  
WITH SERPENTINE  
PULLEY &  
BOLT-ON TANK

# KRC CHEVY CRATE MOTOR COMPLETE SERPENTINE KITS

★ COMPLETE FRONT ENGINE KIT FOR YOUR CRATE MOTOR APPLICATION INCLUDES POWER STEERING PUMP & PULLEY, WATER PUMP, AND ALL THE BRACKETS, BELTS, HARDWARE, 15% WATER PUMP TO CRANK REDUCTION PULLEYS, & SPACERS TO MOVE THE WATER PUMP OUT TO CLEAR THE TAMPER-PROOF BOLTS ON THE TIMING COVER

★ AVAILABLE WITH THE ALTERNATOR PULLEY, BRACKET, & BELT FOR BOTH THE DENSO\* & THE DELCO\*\*

★ AVAILABLE WITH IDLER ASSEMBLY TO HOLD MORE TENSION ON THE BELT



#KRC 16312 010  
COMPLETE KIT WITH HEAD  
MOUNT BRACKET & NO TANK

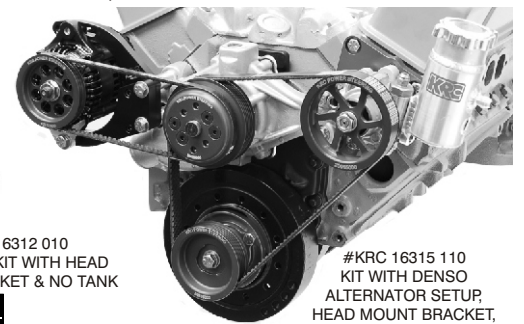

#KRC 16315 110  
KIT WITH DENSO  
ALTERNATOR SETUP,  
HEAD MOUNT BRACKET,  
& BOLT-ON TANK

KRC CHEVY CRATE MOTOR SERPENTINE KITS			
DESCRIPTION	P. S. BRACKET	TANK	PART #
COMPLETE KIT	HEAD	NO TANK	KRC 16312 010
COMPLETE KIT	BLOCK	NO TANK	KRC 16312 015
COMPLETE KIT	HEAD	BOLT-ON	KRC 16312 110
COMPLETE KIT	BLOCK	BOLT-ON	KRC 16312 115
KIT W/ DENSO ALTERNATOR PULLEY, BRKT, & BELT*	HEAD	NO TANK	KRC 16315 010
KIT W/ DENSO ALTERNATOR PULLEY, BRKT, & BELT*	BLOCK	NO TANK	KRC 16315 015
KIT W/ DENSO ALTERNATOR PULLEY, BRKT, & BELT*	HEAD	BOLT-ON	KRC 16315 110
KIT W/ DENSO ALTERNATOR PULLEY, BRKT, & BELT*	BLOCK	BOLT-ON	KRC 16315 115
KIT W/ DELCO ALTERNATOR PULLEY, BRKT, & BELT**	HEAD	NO TANK	KRC 16316 010
KIT W/ DELCO ALTERNATOR PULLEY, BRKT, & BELT**	BLOCK	NO TANK	KRC 16316 015
KIT W/ DELCO ALTERNATOR PULLEY, BRKT, & BELT**	HEAD	BOLT-ON	KRC 16316 110
KIT W/ DELCO ALTERNATOR PULLEY, BRKT, & BELT**	BLOCK	BOLT-ON	KRC 16316 115
KIT WITH IDLER ASSEMBLY	HEAD	NO TANK	KRC 16320 010
KIT WITH IDLER ASSEMBLY	BLOCK	NO TANK	KRC 16320 015
KIT WITH IDLER ASSEMBLY	HEAD	BOLT-ON	KRC 16320 110
KIT WITH IDLER ASSEMBLY	BLOCK	BOLT-ON	KRC 16320 115

\*WILL FIT 2 BOLT DENSO ALTERNATORS MEASURING 138MM (5.43") CENTER-TO-CENTER ON THE MOUNTING HOLES  
\*\*WILL FIT 2 BOLT DELCO ALTERNATORS MEASURING 156MM (6.14") CENTER-TO-CENTER ON THE MOUNTING HOLES

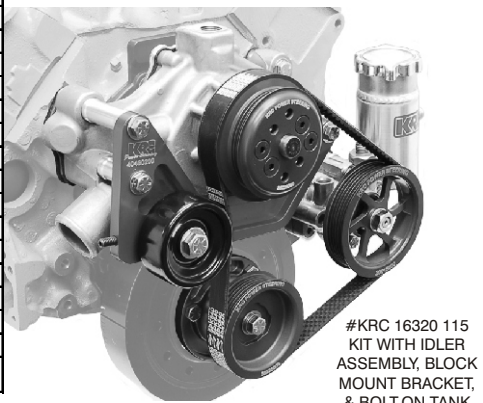

#KRC 16320 115  
KIT WITH IDLER  
ASSEMBLY, BLOCK  
MOUNT BRACKET,  
& BOLT-ON TANK

Place your order at (479) 646-6988, Fax to (479) 646-5939, or visit [www.southwestspeed.com](http://www.southwestspeed.com)



# SOUTHWEST SPEED COMPLETE SBC FRONT ENGINE KITS

- ★THESE ARE THE PERFECT KITS TO EQUIP THE ENTIRE FRONT OF STANDARD SMALL BLOCK CHEVY MOTORS WITH EITHER V-BELT OR SERPENTINE PULLEYS
- ★SOUTHWEST SPEED'S COMPLETE FRONT ENGINE KITS INCLUDE WATER PUMP, POWER STEERING PUMP WITH PULLEY, POWER STEERING PUMP BRACKET, POWER STEERING TANK, WATER PUMP PULLEY, CRANK PULLEY, & BELT
- ★THE V-BELT KITS INCLUDE AN EXTRA BELT FOR THE FRONT GROOVES ON THE WATER PUMP & CRANK PULLEYS
- ★AVAILABLE WITH DIFFERENT SIZE PULLEYS FOR DIFFERENT REDUCTIONS



SWS SMALL BLOCK CHEVY FRONT ENGINE KITS					
PUMP	PULLEY	REDUCTION	P.S. BRACKET	TANK	PART #
STEEL	V-BELT	0% (1 TO 1)	HEAD	REMOTE	410-700
STEEL	V-BELT	0% (1 TO 1)	BLOCK	REMOTE	410-702
STEEL	V-BELT	21%	HEAD	REMOTE	410-704
STEEL	V-BELT	21%	BLOCK	REMOTE	410-706
STEEL	SERPENTINE	30%	HEAD	BOLT-ON	KRC 57711 110
STEEL	SERPENTINE	30%	BLOCK	BOLT-ON	KRC 57711 115
STEEL	SERPENTINE	15%	HEAD	BOLT-ON	KRC 57712 110
STEEL	SERPENTINE	15%	BLOCK	BOLT-ON	KRC 57712 115
STEEL	SERPENTINE	0% (1 TO 1)	HEAD	BOLT-ON	KRC 57713 110
STEEL	SERPENTINE	0% (1 TO 1)	BLOCK	BOLT-ON	KRC 57713 115

## CAST ALUMINUM PULLEYS PULLEY & BELT KITS

- ★SMALL BLOCK CHEVY
- ★0% (1 TO 1) & 21% REDUCTION AVAILABLE
- ★DOUBLE GROOVE
- ★LIGHTWEIGHT ALUMINUM CONSTRUCTION
- ★TWO MATCHED V-BELTS INCLUDED



DESCRIPTION	WATER PUMP	REDUCTION	PART #
PULLEY COMBO	SHORT	0% (1 TO 1)	410-623
PULLEY COMBO	LONG	0% (1 TO 1)	410-624
PULLEY COMBO	SHORT	21%	410-625
PULLEY COMBO	LONG	21%	410-626

## INDIVIDUAL CAST PULLEYS



- ★SMALL BLOCK CHEVY
- ★FOR SHORT OR LONG WATER PUMP
- ★HARD ANODIZED FOR DURABILITY

DESCRIPTION	PART #
WATER PUMP PULLEY, 5 9/16"	410-619
WATER PUMP PULLEY, 7 1/16"	410-620
CRANK PULLEY, 5 9/16", ALIGNS W/LONG PUMP	410-621
CRANK PULLEY, 5 9/16", ALIGNS W/SHORT PUMP	410-622

## SBC ALUM. WATER PUMP

- ★LIGHTWEIGHT ALUMINUM CONSTRUCTION
  - ★SBC, SHORT DESIGN
  - ★DUAL FAN MOUNTING BOLT PATTERN
- PART #410-550



NOTE: SEE PAGE 119 FOR MANY MORE WATER PUMPS

## CRANK PULLEY SPACER

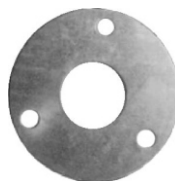

- ★FOR CHEVY LOWER PULLEYS
  - ★.090" ALUMINUM
  - ★SPACES LOWER PULLEY TO MATCH UPPER PULLEY
- PART #410-570

## WATER PUMP PULLEY SHIM KIT

- ★FITS ALL GM AND FORD PUMPS
- ★5/8" OR 3/4" SHAFT
- ★KIT CONTAINS ONE 1/16", ONE 3/32", & ONE 1/8" SPACER



## ALTERNATOR PULLEY

- ★LIGHTWEIGHT BILLET ALUMINUM
- ★FITS GM/DELCO & MOST FORDS
- ★5" OUTSIDE DIAMETER REDUCES ALTERNATOR SPEED FOR HIGH ENGINE RPM APPLICATIONS



Place your order at (479) 646-6988, Fax to (479) 646-5939, or visit [www.southwestspeed.com](http://www.southwestspeed.com)

# KSE TANDEM X POWER STEERING & FUEL PUMPS

- ★TANDEM X PUMPS HAVE THE LATEST IN POWER STEERING PUMP & FUEL PUMP TECHNOLOGY
- ★BELT OR DIRECT DRIVE AVAILABLE
- ★THE .238" PUMPS ARE FOR USE WITH ALCOHOL UP TO 700hp & GAS UP TO 1000hp
- ★THE .297" PUMPS ARE FOR USE WITH ALCOHOL ONLY, UP TO 1000hp
- ★THE KSC1062 PUMPS ARE "CLOCKWISE", WHICH ALLOWS THEM TO BE MOUNTED ON THE FRONT OF THE ENGINE



DESCRIPTION	PART #
KSE BELT DRIVE PUMP, .238"	KSC1064-002
KSE BELT DRIVE PUMP, .297"	KSC1064-004
KSE DIRECT DRIVE PUMP, .238"	KSC1065-002
KSE DIRECT DRIVE PUMP, .297"	KSC1065-004
KSE DIRECT DRIVE PUMP, CW, .238"	KSC1062-002
KSE DIRECT DRIVE PUMP, CW .297"	KSC1062-004
INLET FITTING FOR P.S. & FUEL PUMP	KSM1059
OUTLET FITTING FOR P.S. PUMP	KSM1017
OUTLET FITTING FOR FUEL PUMP	KSM1060
BLANK FUEL PILL	411-728
PILL KIT: 120,140,160,180,200,220,240	KSC1075
FUEL VALVE SPRING	KSC1023
FUEL VALVE POPPET	KSC1031

## TANDEM PUMP ADAPTERS

- ★6061-T6 ALUMINUM CONSTRUCTION
- ★HARDWARE INCLUDED



DESCRIPTION	PART #
DIRECT DRIVE MOUNT, GAMBLER PUMP	411-748
PUMP ADAPTER, SMALL BLOCK CHEVY	411-750
PUMP ADAPTER, BERT/BRINN	411-752
PUMP ADAPTER, 351 WINDSOR	411-755
PUMP ADAPTER, 351 CLEVELAND	411-756

## POWER STEERING FLUID

- ★PREMIUM QUALITY FLUID
- ★HELPS STOP SQUEALS & MINOR LEAKS
- ★RESTORES SMOOTH OPERATION



DESCRIPTION	PART #
POWER STEERING FLUID, 12 OUNCE	940-050
POWER STEERING FLUID, 32 OUNCE	940-052

## POWER STEERING PUMP FITTINGS

- ★ADAPTS GM PUMP TO RACING HOSES

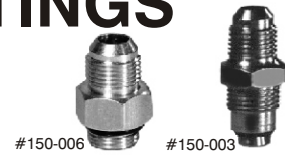

DESCRIPTION	PART #
LATE GM P.S. PUMP OUTLET FITTING 16mm x 1.5 O-RING TO -6 AN	150-003
LATE GM P.S. PUMP INLET FITTING -10 AN O-RING TO -10 AN	150-006

## POWER STEERING BOX FITTINGS

- ★AVAILABLE FOR PRE-1982 AND 1982 & NEWER POWER STEERING BOXES
- ★EACH BOX TAKE 1 SMALL & 1 LARGE FITTING



DESCRIPTION	PART #
PRE-1982 P.S. BOX FITTING, SMALL 5/8"-18 TO -6 AN	150-014
PRE-1982 P.S. BOX FITTING, LARGE 11/16"-18 TO -6 AN	150-016
1982-NEWER P.S. BOX FITTING, SMALL 16mm x 1.5 O-RING TO -6 AN	150-010
1982-NEWER P.S. BOX FITTING, LARGE 18mm x 1.5 O-RING TO -6 AN	150-012

## POWER STEERING HOSE KITS

- ★KITS WITH 2 HOSES ARE AVAILABLE FOR "COMBO" PUMPS THAT HAVE RESERVOIRS BOLTED ON THE PUMP
- ★KITS WITH 3 HOSES ARE AVAILABLE FOR APPLICATIONS WITH REMOTE RESERVOIRS
- ★BOTH STYLES ARE AVAILABLE IN RUBBER & HIGH PRESSURE STEEL BRAID
- ★INCLUDES -6AN PRESSURE LINES WITH HOSE ENDS & 3 HOSE SET INCLUDES -10AN SUPPLY LINE WITH HOSE ENDS
- ★FITS STOCK GM BOXES & POWER RACKS

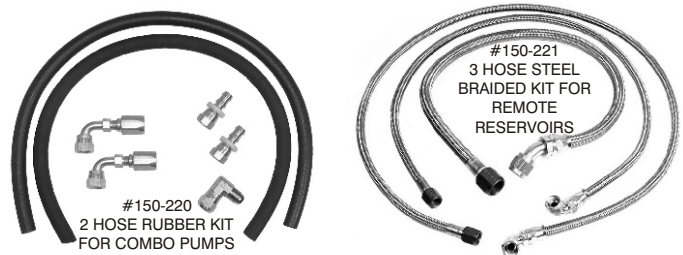

DESCRIPTION	PART #
HOSE KIT FOR COMBO PUMP, RUBBER	150-220
HOSE KIT FOR COMBO PUMP, STEEL	150-2201
HOSE KIT FOR REMOTE TANK, RUBBER	150-2203
HOSE KIT FOR REMOTE TANK, STEEL	150-221

Place your order at (479) 646-6988, Fax to (479) 646-5939, or visit [www.southwestspeed.com](http://www.southwestspeed.com)

# RACK & PINIONS POWER STEERING UNIT

- ★TAPERED OR THREADED SHAFTS
- ★SIMPLE INSTALLATION
- ★3/4" x 30 SPLINE PINION

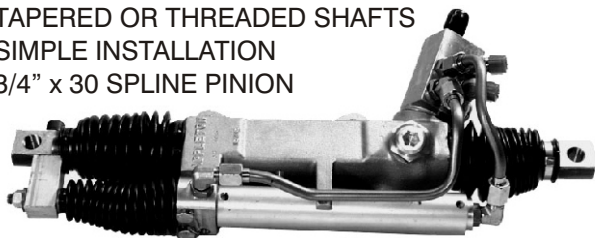

DESCRIPTION	PART #
2.0" POWER MEDIUM, 18.25" TAPERED	105-434
2.0" POWER MEDIUM, 18.25" THREADS	105-4341
2.5" POWER MEDIUM, 18.25" TAPERED	105-436
2.5" POWER MEDIUM, 18.25" THREADS	105-4361
3.0" POWER MEDIUM, 18.25" TAPERED	105-438
3.0" POWER MEDIUM, 18.25" THREADS	105-4381
3.0" POWER LIGHT, 18.25" TAPERED	105-439
3.0" POWER LIGHT, 18.25" THREADS	105-4391
3.4" POWER LIGHT, 18.25" TAPERED	105-440
3.4" POWER LIGHT, 18.25" THREADS	105-4401
3.0" POWER LIGHT, 19.25" THREADS	105-448
3.0" POWER LIGHT, 19.75" THREADS	105-4481
3.4" POWER LIGHT, 19.25" THREADS	105-450

## POWER RACK REPAIR PARTS



DESCRIPTION	PART #
POWER SERVO, 2.5" MEDIUM	105-483
POWER SERVO, 3.0" MEDIUM	105-488
POWER SERVO, 3.0" LIGHT	105-489
POWER SERVO, 3.4" LIGHT	105-490
SERVO RING COMPRESSOR	105-500
BOOT, RACK SHAFT, EACH	105-502
BOOT, SLAVE CYLINDER, EACH	105-503
LINE SET, STEEL	105-506
FITTING, 90°	105-507
FITTING, 45°	105-508
RACK SHAFT, 18 1/4" TAPERED	105-512
RACK SHAFT, 19 1/4" THREADED	105-513
RACK BUSHING, FITS ALL RACKS	105-514
RACK SNAP RING, FITS ALL RACKS	105-515
NYLON SCREW & NUT ADJ, BRONZE	105-517
ALUMINUM SCREW & NUT ADJUSTER	105-518
SERVO SEAL KIT	105-535
SLAVE CYLINDER, COMPLETE	105-550
SLAVE CYLINDER REBUILD KIT	105-555
SLAVE CYLINDER PISTON	105-554
SLAVE CYLINDER SEAL KIT	105-557
SLAVE CYLINDER SHAFT ONLY	105-560
SLAVE TO RACK MNT. W/BOLTS	105-565
RACK ROCK GUARD	105-570

# RACK & PINIONS MANUAL STEERING UNIT

- ★18 1/4" EYE TO EYE TAPERED SHAFT
- ★3/4" x 48 SPLINE PINION



DESCRIPTION	PART #
1.75" MANUAL RACK & PINION	105-403
2.00" MANUAL RACK & PINION	105-404
2.50" MANUAL RACK & PINION	105-406
3.00" MANUAL RACK & PINION	105-408
3.40" MANUAL RACK & PINION	105-410

## MANUAL STEERING PARTS

DESCRIPTION	PART #
BOOT, RACK SHAFT, EACH	105-502
RACK SHAFT, 18 1/4" TAPERED	105-512
RACK BUSHING, FITS ALL RACKS	105-514
RACK SNAP RING, FITS ALL RACKS	105-515

## RACK & PINION MOUNT



PART #105-800

- ★EXCLUSIVE FORMED DESIGN
- ★INCLUDES BOTTOM GUSSET

## STEERING SHAFT BEARINGS OVERSIZED ROD ENDS

- ★MOUNTS STEERING SHAFT TO COLUMN MOUNT
- ★3/4" RIGHT HAND THREAD



THREAD	BORE	ALUMINUM	STEEL
3/4" -16R	.757	103-113	103-013

## FLANGED BEARINGS



- ★MOUNTS STEERING SHAFT TO FIREWALL
- ★SELF ALIGNING BEARING

DESCRIPTION	PART #
.750" FLANGED BEARING MOUNT ASSY.	150-289
.757" FLANGED BEARING MOUNT ASSY.	150-290

## SHAFT CLAMP COLLAR

- ★CLAMPS STEERING SHAFT FIRMLY IN PLACE
- ★LIGHTWEIGHT ALUMINUM CONSTRUCTION
- ★3/4" I.D.

PART #150-278



Place your order at (479) 646-6988, Fax to (479) 646-5939, or visit [www.southwestspeed.com](http://www.southwestspeed.com)



# STEERING SHAFTS FIXED SHAFTS

- ★ WELDABLE STEEL STEERING SHAFT
- ★ 3/4" O.D. x 48" OR 72" LONG
- ★ TUBULAR SHAFT REQUIRES OVERSIZED BEARINGS, SUCH AS #103-013 OR #103-113
- ★ SHAFT W/ 3/4"-36 SPLINES ON ONE END IS AVAILABLE



DESCRIPTION	PART #
TUBULAR SHAFT, 48" LONG	150-280
TUBULAR SHAFT, 3/4"-36 SPLINE, 48"	150-281
TUBULAR SHAFT, 72" LONG	150-284

# TELESCOPING SHAFT

- ★ TELESCOPING SHAFTS ARE SAFER IN RACING APPLICATIONS & ALSO EASIER TO INSTALL
- ★ SOLD COMPLETE WITH 3/4" OVERSIZED STEERING ROD END FOR MOUNTING & PULL-TYPE STEERING DISCONNECT
- ★ REQUIRES 3/4"-20 U-JOINT OR COUPLER
- ★ AVAILABLE IN SHORT & LONG VERSION



DESCRIPTION	PART #
TELESCOPING SHAFT, SHORT, 22"-32"	150-2856
TELESCOPING SHAFT, LONG, 32"-42"	150-2858

# COLUMN MOUNTS WELD-ON

- ★ LIGHTWEIGHT STEEL
- ★ 3/4" ROD END SLOT
- ★ WELD TO DASH BAR
- ★ MEASUREMENTS ARE TAKEN FROM CENTER OF SLOT TO EDGE OF TUBE

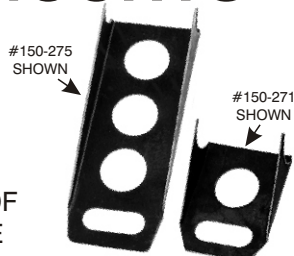

DESCRIPTION	PART #
WELD-ON MOUNT, 1 1/4" SLOT-TO-EDGE	150-268
WELD-ON MOUNT, 1 3/4" SLOT-TO-EDGE	150-269
WELD-ON MOUNT, 2 3/4" SLOT-TO-EDGE	150-271
WELD-ON MOUNT, 6 3/4" SLOT-TO-EDGE	150-275

# CLAMP-ON

- ★ LIGHTWEIGHT & STRONG MACHINED ALUMINUM
- ★ FITS 1 1/2" OR 1 3/4" TUBE
- ★ MOUNTS MEASURE 7" CENTER OF TUBE TO CENTER OF BEARING
- ★ OVERSIZE BEARING INCLUDED

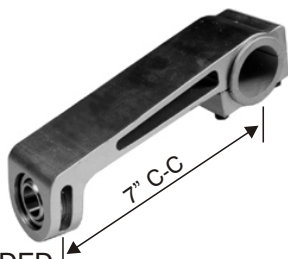

DESCRIPTION	PART #
CLAMP-ON MOUNT, 1 1/2" TUBE	150-265
CLAMP-ON MOUNT, 1 3/4" TUBE	150-267

# STEERING U-JOINTS & COUPLERS

- ★ CONNECTS STEERING TO SHAFT
- ★ AVAILABLE 3/4" SMOOTH (FOR WELDING), 3/4" DD, AND IN SEVERAL SPLINES



DESCRIPTION	U-JOINT COUPLER	
3/4" SMOOTH - 3/4" SMOOTH	105-906	105-956
3/4" DD - 3/4" DD	105-9181	
9/16"-26 SPLINE - 3/4" SM.	105-902	105-952
9/16"-26 SPLINE - 3/4" DD	105-9256	
5/8"-36 SPLINE - 3/4" SMOOTH	105-9158	105-954
5/8"-36 SPLINE - 3/4" DD	105-9159	
3/4"-20 SPLINE - 3/4" SMOOTH	105-907	105-957
3/4"-30 SPLINE - 3/4" SMOOTH	105-908	105-958
3/4"-36 SPLINE - 3/4" SMOOTH	105-910	105-960
3/4"-36 SPLINE - 3/4" DD	105-9171	
3/4"-48 SPLINE - 3/4" SMOOTH	105-912	105-962
3/4"-48 SPLINE - 3/4" DD	105-9174	
13/16"-36 SPLINE - 3/4" SM.	105-914	105-964
13/16"-36 SPLINE - 3/4" DD	105-9194	

NOTE: IF YOUR SHAFT HAS A FLAT SIDE, COUNT HALF OF THE SPLINES AND MULTIPLY BY 2.

# POWER STEERING BOXES

- ★ LIGHT VALVING ENABLES STEERING WITH LESS EFFORT & FIRM VALVING REQUIRES STEERING WITH MORE EFFORT
- ★ -6AN FITTINGS
- ★ CADMIUM PLATED

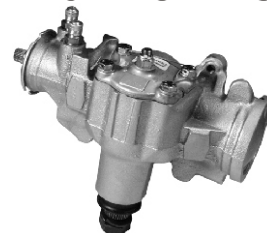

RATIO	VALVING	SPLINE	PART #
12:1	LIGHT	3/4"-30	105-302
12:1	LIGHT	13/16"-36	105-303
12:1	MEDIUM	3/4"-30	105-304
12:1	MEDIUM	13/16"-36	105-305
12:1	FIRM	3/4"-30	105-306
12:1	FIRM	13/16"-36	105-307
14:1	LIGHT	3/4"-30	105-312
14:1	LIGHT	13/16"-36	105-313
14:1	MEDIUM	3/4"-30	105-314
14:1	MEDIUM	13/16"-36	105-315
14:1	FIRM	3/4"-30	105-316
14:1	FIRM	13/16"-36	105-317
16:1	LIGHT	3/4"-30	105-322
16:1	LIGHT	13/16"-36	105-323
16:1	MEDIUM	3/4"-30	105-324
16:1	MEDIUM	13/16"-36	105-325
16:1	FIRM	3/4"-30	105-326
16:1	FIRM	13/16"-36	105-327

POWER STEERING BOX FITTINGS ARE ON PAGE 56

Place your order at (479) 646-6988, Fax to (479) 646-5939, or visit [www.southwestspeed.com](http://www.southwestspeed.com)

# STEERING WHEELS



★LIGHTWEIGHT ALUMINUM WHEELS  
★DISHED & FLAT, FOAM PADDED & UNCOATED AVAILABLE



FOAM PADDED	BLACK	BLUE	RED
13", 3 SPOKE, DISH, KART	150-292		
15", 3 SPOKE, DISHED	150-302	150-303	150-304
15", 4 SPOKE, DISHED	150-307		
17", 3 SPOKE, DISHED	150-312	150-313	150-314

UNCOATED 3 SPOKE	SILVER	BLACK
14" DISHED, SMOOTH	LON 56834	
14" DISHED, DRILLED	LON 56835	LON 56833
15" DISHED, SMOOTH	LON 56836	
15" DISH SMOOTH W/BUMPS	LON 56822	
15" DISHED, DRILLED	LON 56837	LON 56838
15" FLAT, DRILLED, SPRINT	LON 56866	LON 56867

# STEERING HUB PADS

★INSTALLS EASILY ON STEERING WHEEL  
★AVAILABLE FOR DISH & FLAT WHEELS  
★REDUCES CHANCE OF INJURY

COLOR	DISH	FLAT
BLACK	150-362	150-372
BLUE	150-363	150-373
RED	150-364	150-374
YELLOW	N/A	150-375
ORANGE	150-366	N/A



# QUICK DISCONNECTS

## PULL, 360° RING TYPE

★SPLINED, 360 DEGREE, PULL TYPE  
★LIGHTWEIGHT ALUMINUM HUB  
★1 1/4"-20 SPLINED, STEEL MANDREL  
★3/4" BORE

SPLINED MANDREL #150-352

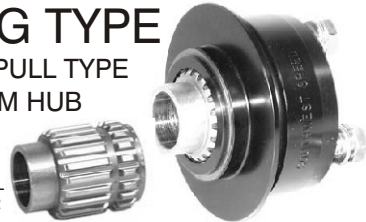

DESCRIPTION	PART #
360° RING TYPE ASSEMBLY	150-350
SPLINED MANDREL ONLY FOR #150-350	150-352

## PUSH BUTTON TYPE

★AVAILABLE W/ HEX OR SPLINED STEEL MANDRELS  
★LIGHTWEIGHT ALUMINUM HUBS  
★3/4" BORES

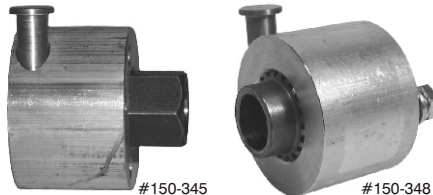

DESCRIPTION	PART #
PUSH BUTTON TYPE ASSEMBLY, HEX	150-345
PUSH BUTTON TYPE ASSEMBLY, SPLINED	150-348
MANDREL ONLY FOR #150-345, HEX	150-347
MANDREL ONLY FOR #150-348, SPLINED	150-349

# STEERING REDUCERS

-LIGHTWEIGHT ALUMINUM HOUSINGS  
-DURABLE, COMPACT DESIGNS  
-ROLLER BEARINGS ALLOW SMOOTH MOVEMENT  
-3/4"-36 SPLINES & HEAT TREATED GEARS  
-1.5 TO 1 RATIO GIVES:  
\*REDUCTION OF 33% OR INCREASE OF 50%  
-2 TO 1 RATIO GIVES:  
\*REDUCTION OF 50% OR INCREASE OF 100%

## EXTRA LIGHTWEIGHT REDUCER

★2 TO 1 RATIO  
★WEIGHS ONLY 1.80 LBS  
★LIGHTEST DESIGN ON THE MARKET TODAY

PART #150-240



## LIGHTWEIGHT REDUCERS

★AVAILABLE IN BOTH 1.5 TO 1 & 2 TO 1 RATIOS  
★WEIGHS 2.40 LBS

PART #150-2502 1.5 TO 1

PART #150-2552 2 TO 1



## STANDARD REDUCER

★2 TO 1 RATIO  
★WEIGH JUST OVER 3 LBS

PART # 150-255

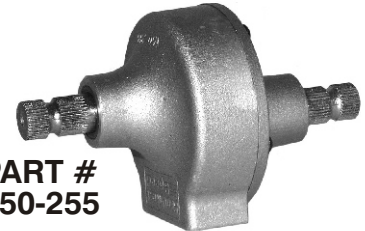

## REPLACEMENT GEARS

FOR REDUCER	RING GEAR	PINION
#150-240, LW 2 TO 1	150-2403	150-2402
#150-250, 1.5 TO 1 (OLD)	150-257	150-251
#150-255, 2 TO 1	150-257	150-256

## REDUCER MOUNTS

★FOR USE WITH #150-240, #150-250, #150-2502, #150-255, #150-2552, & OTHER SIMILAR STEERING REDUCERS  
★DESIGNED FOR QUICK & EASY WELD-ON INSTALLATION



#150-2591 & #150-259

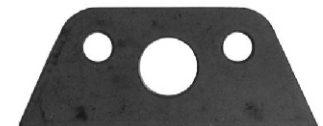

#150-2593

DESCRIPTION	PART #
EXTENDED MOUNT, 3/16" THICK	150-2591
EXTENDED MOUNT, 1/4" THICK	150-259
DASH BAR MOUNT, 3/16" THICK	150-2593

Place your order at (479) 646-6988, Fax to (479) 646-5939, or visit [www.southwestspeed.com](http://www.southwestspeed.com)

# BUMP STEER 2" SPACER KIT

- ★ TAPERED DESIGN
- ★ COMES WITH .100", .200", & .300" SHIMS
- ★ USED WITH 5/8" ROD END
- ★ USED WITH #105-086 BOLT



**PART #105-084**

# GRADE 8 BOLT & NUT FOR SPACER KIT

- ★ GRADE 8
- ★ COMES WITH LOCK NUT
- ★ 5/8"-18 THREADS
- ★ 4 1/2" LONG
- ★ USED W/ 5/8" ROD END



**PART #105-086**

# STUD KITS

- ★ TAPERED DESIGN
- ★ NO NEED TO DRILL SPINDLE
- ★ COMPLETE WITH NUTS AND SPACERS

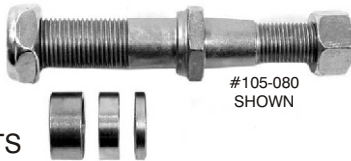

#105-080 SHOWN

DESCRIPTION	PART #
METRIC SPINDLE, SHORT STUD	105-080
PINTO SPINDLE, LONG STUD	105-082

# BOLTS & SPACERS

- ★ USE WITH 5/8"-18 ROD ENDS
- ★ ADJUSTS BUMP STEER
- ★ SHIMS PRICED EACH & SOLD IN BAGS OF 10



DESCRIPTION	PART #
.050" BUMP STEER SHIM	105-064
.100" BUMP STEER SHIM	105-066
.150" BUMP STEER SHIM	105-067
.200" BUMP STEER SHIM	105-068
.250" BUMP STEER SHIM	105-069
.300" BUMP STEER SHIM	105-070
.375" BUMP STEER SHIM	105-072
5/8" x 3" SPINDLE BOLT (EACH), GRADE 9	105-060
5/8" x 4 1/2" BOLT & NUT (EACH), GRADE 8	105-086

# RACING TIE ROD ENDS

- ★ THESE ARE THE MOST POPULAR TIE ROD ENDS ON MODIFIEDS & MANY OTHER CLASSES
- ★ ALSO WORK GREAT FOR RACK & PINIONS WITH TAPERED EYES
- ★ ALL COMPONENTS ARE BRAND NEW & ALL NECESSARY HARDWARE IS INCLUDED
- ★ \*\*#105-8311, #105-8321, & #105-8201 ARE EXCLUSIVE SOUTHWEST SPEED ENDS W/ THE GREASE FITTING IN THE END (INSTEAD OF THE BOTTOM) GIVING EXTRA CLEARANCE AWAY FROM THE CROSS-MEMBER
- ★ AVAILABLE WITH 5/8"-18 LEFT & RIGHT HAND THREADS IN BOTH 4" & 7 1/4" LONG DESIGNS (MEASURED CENTER OF PIN TO END OF THREADS)

MAINLY USED AS INNER TIE ROD ENDS	PART #
4" LONG, 5/8"-18 LEFT, MOD. END**	105-8311
4" LONG, 5/8"-18 RIGHT, MOD. END**	105-8321
7 1/4" LONG, 5/8"-18 LEFT, MOD. END	105-819
7 1/4" LONG, 5/8"-18 RIGHT, MOD. END	105-820
7 1/4" LONG, 5/8"-18 RIGHT, MOD. END**	105-8201
MAINLY USED AS OUTER TIE ROD ENDS	PART #
4" LONG, 5/8"-18 LEFT, MOD. END	105-831
4" LONG, 5/8"-18 RIGHT, MOD. END	105-832

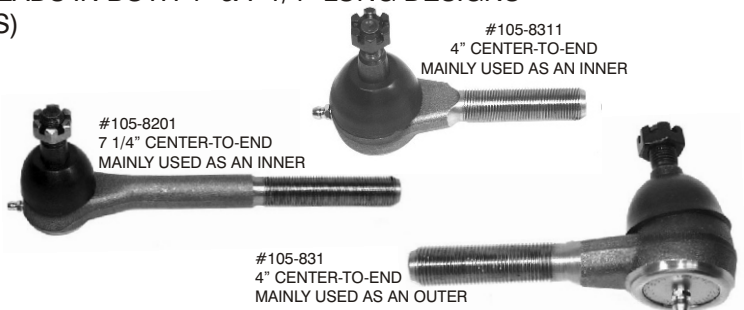

# SPINDLES PINTO/MUSTANG II

- ★ 100% NEW FORGED STEEL
- ★ REPLACES STOCK SPINDLES
- ★ 10 DEGREE PIN INCLINATION
- ★ WORK GREAT WITH GRANADA HUBS & ROTORS (PAGE 64), CORRESPONDING BEARING KIT (PAGE 66), PINTO BRAKE BRACKETS (PAGE 62), & GM METRIC CALIPERS (PAGE 68)
- ★ #104-3901 & #104-3921 HAVE THE STEERING ARM TAPPED 5/8"-18
- ★ #104-3902 & #104-3922 HAVE THE STEERING ARM TAPPED 5/8"-18 & THE LOWER BALL JOINT HOLE REAMED FOR THE 64-72 CHEVELLE PRESS-IN BALL JOINTS (#101-011 & #101-012)



RIGHT HAND SHOWN

DESCRIPTION	PART #
STOCK, LEFT HAND	104-390
STOCK, RIGHT HAND	104-392
TAPPED 5/8"-18, LEFT HAND	104-3901
TAPPED 5/8"-18, RIGHT HAND	104-3921
TAPPED 5/8"-18 & REAMED, LEFT HAND	104-3902
TAPPED 5/8"-18 & REAMED, RIGHT HAND	104-3922

# 2" DROP PINTO/MUSTANG II

- ★ THESE SPINDLES MAINTAIN FRONT END GEOMETRY ELIMINATING EXCESSIVE SUSPENSION & TIRE WEAR THAT ARE COMMON IN OTHER FORMS OF LOWERING
- ★ GREAT FOR USE ON HOT RODS, STREET RODS, RESTORATION PROJECTS, & ANY CIRCLE TRACK RACE CAR WHERE THE RULES ALLOW
- ★ JUST LIKE THE STOCK SPINDLES, THEY WILL WORK GREAT WITH GRANADA HUBS & ROTORS, BEARING KIT, SPECIALLY DESIGNED PINTO BRAKE BRACKETS, & GM METRIC CALIPERS

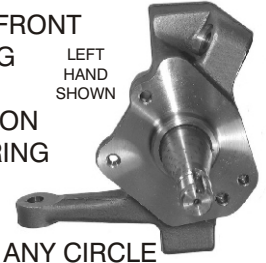

LEFT HAND SHOWN

DESCRIPTION	PART #
2" DROP, LEFT HAND	104-3950
2" DROP, RIGHT HAND	104-3951

Place your order at (479) 646-6988, Fax to (479) 646-5939, or visit [www.southwestspeed.com](http://www.southwestspeed.com)



# SPINDLES

## STANDARD WIDE 5

- ★11 3/4" O.D. ROTOR
- ★8 3/4" TALL ON LEFTS & RIGHTS
- ★7° PIN INCLINATION
- ★5/8" THREADED STEERING BOSS



### STANDARD WIDE 5 PRESS-IN LOWER BALL JOINT

ROTOR WIDTH	CAL. TYPE	LEFT HAND	RIGHT HAND
1.250"	GM	104-002	104-004
.810"	DL	104-012	104-014
1.250"	DL	104-022	104-024
.810"	SL	104-032	104-034
1.250"	SL	104-042	104-044
NO BRAKE BRACKET		104-052	104-054

### STANDARD WIDE 5 SCREW-IN LOWER BALL JOINT

ROTOR WIDTH	CAL. TYPE	LEFT HAND	RIGHT HAND
1.250"	GM	104-108	104-110
.810"	DL	104-112	104-114
1.250"	DL	104-122	104-124
.810"	SL	104-132	104-134
1.250"	SL	104-142	104-144
NO BRAKE BRACKET		104-152	104-154

## TALL WIDE 5

- ★11 3/4" O.D. ROTOR
- ★11" TALL ON LEFTS & 10 1/4" TALL ON RIGHTS
- ★7° PIN INCLINATION
- ★5/8" THREADED STEERING BOSS



### TALL WIDE 5 PRESS-IN LOWER BALL JOINT

ROTOR WIDTH	CAL. TYPE	LEFT HAND	RIGHT HAND
.810"	DL	104-062	104-064
1.250"	DL	104-072	104-074
1.250"	DL	104-372*	104-374*
.810"	SL	104-082	104-084
1.250"	SL	104-092	104-094
NO BRAKE BRACKET		104-102	104-104

\* #104-372 & #104-374 HAVE SHORTENED STEERING ARMS

### TALL WIDE 5 SCREW-IN LOWER BALL JOINT

ROTOR WIDTH	CAL. TYPE	LEFT HAND	RIGHT HAND
.810"	DL	104-162	104-164
1.250"	DL	104-172	104-174
.810"	SL	104-182	104-184
.810"	SL	-	104-185*
1.250"	SL	104-192	104-194
1.250"	SL	104-1921*	104-1941*
NO BRAKE BRACKET		104-202	104-204

\* #104-1921 HAS A SHORTENED STEERING ARM

\* #104-185 & #104-1941 ARE 1/2" SHORTER IN HEIGHT

# SPINDLES

## STOCK

- ★WE NOW HAVE MANY OE REPLACEMENT SPINDLES;
- ★SEE [southwestspeed.com](http://southwestspeed.com) FOR THE FULL SELECTION



DESCRIPTION	PART #
28-48 FORD SPINDLES	103-9749
49-54 CHEVY SPINDLES, STRAIGHT AXLE	103-9755
64-72 A-BODY & 67-69 F-BODY SPINDLES	103-9801
64-72 A-BODY SPINDLES, 2" DROP	103-9770
67-69 F-BODY SPINDLES, 2" DROP	103-9767

## 5 x 5

- ★11 3/4" O.D. x 1 1/4" ROTOR
- ★10° PIN INCLINATION
- ★USES SUPERLITE CALIPERS
- ★LEFT SIDE HAS AN ADJUSTABLE, SERRATED ACKERMAN WASHER

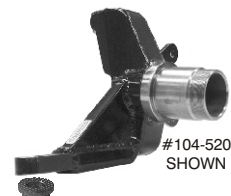

### 5x5 PRESS-IN LOWER BALL JOINT

ROTOR WIDTH	CAL. TYPE	WHEEL BEARING	LEFT HAND	RIGHT HAND
1.250"	SL	QC368A	104-479	104-482
1.250"	SL	QC368A	104-480*	N/A
1.250"	SL	L610549	104-520	104-522
NO BRAKE BRACKET		L610549	104-595*	104-598*

\* SPINDLE PINS HAVE BEEN RAISED 1/2"

# SPINDLE PARTS

## SPINDLE SNOOTS



PART #105-0006  
PINTO/MUSTANG II  
PART #105-001  
WELD-ON WIDE 5

## ACKERMAN ADJUSTERS

- ★SERRATED WASHER OR BLOCK TO ADJUST ACKERMAN



PART #  
104-799

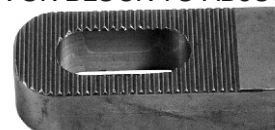

PART #  
104-797

## SPINDLE BOSSES



USE WITH GM LOWER BALL JOINT	USE WITH CHRYSLER LOWER BALL JOINT	USE WITH GM UPPER BALL JOINT	1/2"-20 x 2" THREADED	5/8"-18 x 1 3/8" THREADED
PART # 105-010	PART # 105-012	PART# 105-014	PART # 105-0236	PART # 105-024

## GM METRIC SPINDLE SAVERS

- ★FOR USE WITH 78-88 GM METRIC SPINDLES
- ★STRONG STEEL CONSTRUCTION
- ★STRENGTHENS THE WEAK STEERING ARM & ALSO ENSURES THAT IS STRAIGHT



LEFT PART #105-095  
RIGHT PART #105-096

Place your order at (479) 646-6988, Fax to (479) 646-5939, or visit [www.southwestspeed.com](http://www.southwestspeed.com)

# BRAKE BRACKETS

## FRONT BRAKE BRACKETS



- ★BIG GM FRONT
  - ★WELD-ON ROUND
  - ★7.05" BOLT CENTERS
- PART #105-040**

- ★DYNALITE DUAL FRONT
  - ★WELD-ON RECTANGLE
  - ★5.25" BOLT CENTERS
- PART #105-044**



- ★DYNALITE DUAL FRONT
  - ★WELD-ON ROUND
  - ★5.25" BOLT CENTERS
- PART #105-045**

- ★DYNALITE SINGLE
  - ★WELD-ON RECTANGLE
  - ★3.26" BOLT CENTERS
- PART #105-049**



- ★SUPERLITE FRONT
  - ★WELD-ON RECTANGLE
  - ★3.50" BOLT CENTERS
- PART #105-048**

- ★SUPERLITE FRONT
  - ★WELD-ON ROUND
  - ★3.50" BOLT CENTERS
- PART #105-047**

## PINTO SPINDLE/GM METRIC BRACKETS

- ★DESIGNED TO PUT GM METRIC CALIPERS ON PINTO/MUSTANG II SPINDLES
- ★BOLT-ON SETUP WITH 5.46" BOLT CENTERS
- ★#105-055 & #105-056 WORK WITH THE ORIGINAL DESIGN GRANADA ROTORS (#203-851, #203-8516, #203-8518, & #203-852)
- ★#105-0553 & #105-0563 WORK WITH THE LIGHTER, 2ND DESIGN ROTORS (#203-8508)
- ★#105-0570 & #105-0571 ARE SPECIFICALLY FOR THE 2" DROP PINTO SPINDLES

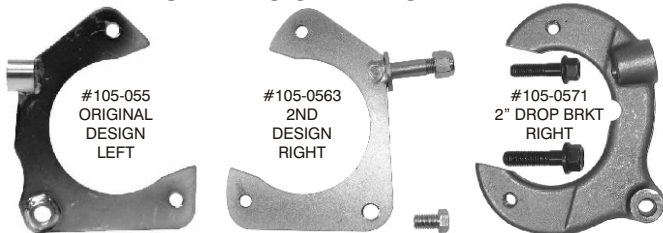

DESCRIPTION	PART #
ORIGINAL DESIGN, LEFT HAND BRKT	105-055
ORIGINAL DESIGN, RIGHT HAND BRKT	105-056
2ND DESIGN, LEFT HAND BRKT	105-0553
2ND DESIGN, RIGHT HAND BRKT	105-0563
2" DROP SPINDLE BRKT, LEFT HAND	105-0570
2" DROP SPINDLE BRKT, RIGHT HAND	105-0571

# BRAKE BRACKETS

## REAR BRACKETS - WELD-ON FORMED BIG GM REAR



- ★WELDS TO 3" TUBE
  - ★FORMED GUSSETS
  - ★MACHINED CALIPER GUIDES
  - ★7.05" BOLT CENTERS
- PART #203-150**

## FLAT BIG GM REAR

- ★WELDS TO 3" TUBE
  - ★FLAT STYLE
  - ★MACHINED CALIPER GUIDES
  - ★7.05" BOLT CENTERS
- PART #203-152**

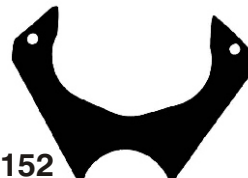

## GM METRIC REAR

- ★AVAILABLE TO WELD TO 3", 3 1/4", 3 1/2", & 4" TUBING
- ★#203-155 WORKS WITH STOCK GM METRIC REAR ENDS
- ★FLAT STYLE
- ★5.46" BOLT CENTERS



DESCRIPTION	PART #
GM METRIC BRKT, 3" O.D. TUBE	203-154
GM METRIC BRKT, 3 1/4" O.D. TUBE	203-1541
GM METRIC BRKT, 3 1/2" O.D. TUBE	203-155
GM METRIC BRKT, 4" O.D. TUBE	203-1551

## DYNALITE DUAL REAR

- ★WELDS TO 3" TUBE
- ★FLAT STYLE
- ★5.25" BOLT CENTERS



**PART #203-156**

## DYNALITE SINGLE REAR

- ★WELDS TO 3" TUBE
- ★FLAT STYLE
- ★3.26" BOLT CENTERS



**PART #203-158**

## SUPERLITE REAR

- ★WELDS TO 3" TUBE
- ★FLAT STYLE
- ★3.50" BOLT CENTERS



**PART #203-160**

# GM CALIPER BOLTS

- ★ONE OR TWO PIECE, HEAT TREATED BOLTS
- ★REPLACES STOCK GM BOLTS & WILL WORK WITH GM METRIC & BIG GM CALIPERS
- ★#105-0549 INCLUDES 2 CALIPER BOLTS & THE BOLTS & WASHERS TO PUT A GM METRIC CALIPER BRACKET (#105-055 OR #105-056) ON A PINTO SPINDLE



DESCRIPTION	PART #
1 PIECE CALIPER BOLT	203-099
2 PIECE CALIPER BOLT WITH BUSHING	203-098
PINTO SPINDLE/METRIC CALIPER KIT	105-0549

Place your order at (479) 646-6988, Fax to (479) 646-5939, or visit [www.southwestspeed.com](http://www.southwestspeed.com)

# BRAKE BRACKETS

## REAR BRACKETS - CLAMP-ON

### BIG GM

- ★CLAMPS TO 3" TUBE
- ★EXCLUSIVE 2-PIECE DESIGN
- ★INTEGRAL SET SCREW BOSS
- ★7.05" BOLT CENTERS
- ★AVAILABLE IN THIN & WIDE CLAMP COLLAR DESIGN



DESCRIPTION	PART #
BIG GM CLAMP-ON, 1 1/2" WIDE COLLAR	203-1999
BIG GM CLAMP-ON, 2 1/4" WIDE COLLAR	203-200

### GM METRIC

- ★CLAMPS TO 3" TUBE
- ★EXCLUSIVE 2-PIECE DESIGN
- ★INTEGRAL SET SCREW BOSS
- ★5.46" BOLT CENTERS
- ★AVAILABLE IN THIN & WIDE CLAMP COLLAR DESIGN



DESCRIPTION	PART #
GM METRIC CLAMP-ON, 1 1/2" WIDE	203-201
GM METRIC CLAMP-ON, 2 1/4" WIDE	203-202

### DYNALITE STEEL

- ★CLAMPS TO 3" TUBE
- ★2 1/4" WIDE CLAMP
- ★EXCLUSIVE 2-PIECE DESIGN
- ★INTEGRAL SET SCREW BOSS
- ★5.25" BOLT CENTERS



**PART #203-204**

### SUPERLITE STEEL

- ★CLAMPS TO 3" TUBE
- ★2 1/4" WIDE CLAMP
- ★EXCLUSIVE 2-PIECE DESIGN
- ★INTEGRAL SET SCREW BOSS
- ★3.50" BOLT CENTERS



**PART #203-206**

### DYNALITE ALUMINUM

- ★LIGHTWEIGHT ALUMINUM CONSTRUCTION
- ★CLAMPS TO 3" TUBE
- ★1" WIDE CLAMP
- ★EXCLUSIVE 2-PIECE DESIGN
- ★POSITIVE LOCK BOLT
- ★5.25" BOLT CENTERS



**PART #203-224**

### SUPERLITE ALUMINUM

- ★LIGHTWEIGHT ALUMINUM CONSTRUCTION
- ★CLAMPS TO 3" TUBE
- ★1" WIDE CLAMP
- ★EXCLUSIVE 2-PIECE DESIGN
- ★POSITIVE LOCK BOLT
- ★3.50" BOLT CENTERS

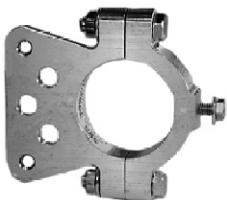

**PART #203-226**

# BRAKE BRACKETS

## REAR BRACKETS - CLAMP-ON

### DYNALITE ALUMINUM BOLT-ON



- ★LIGHTWEIGHT ALUMINUM
- ★BOLTS TO A #570-487 TO MAKE A DYNALITE CLAMP-ON BRAKE BRACKET
- ★5.25" BOLT CENTERS

**PART #203-234**

### SUPERLITE ALUMINUM BOLT-ON

- ★LIGHTWEIGHT ALUMINUM
- ★BOLTS TO A #570-487 TO MAKE A SUPERLITE CLAMP-ON BRAKE BRACKET
- ★3.50" BOLT CENTERS

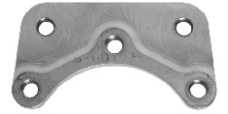

**PART #203-236**

### BOLT TOGETHER, CLAMP-ON



- ★LIGHTWEIGHT ALUMINUM
- ★CLAMPS TO 3" TUBE
- ★1" WIDE CLAMP
- ★WORKS AS RETAINING RING WITH BOLT-ON BRAKE BRACKET
- ★USE WITH #203-234 & #203-236

**PART #570-487**

# STAKE BOLT

- ★THREADS INTO THE TOP OF CLAMP-ON BRACKETS TO HOLD THEM IN PLACE
- ★3/8" COARSE THREADS; 3/4" LONG
- ★SOLD IN A PACK OF 4



**PART #986-053**

# ROTOR BOLT KITS

- ★5/16"-18 x 1" COARSE THREAD, ALLEN HEAD BOLTS OR 5/16"-24 x 7/8" FINE THREAD, 12 PT BOLTS
- ★COMES W/ EITHER LOCK WASHERS OR LOCK NUTS



#203-104 SHOWN

DESCRIPTION	PART #
FINE, 8 BOLT W/ LOCK WASHERS	203-104
COARSE, 8 BOLT W/ LOCK WASHERS	203-106
COARSE, 10 BOLT W/ LOCK WASHERS	203-108
COARSE, 8 BOLT W/ LOCK NUTS	203-110
COARSE, 10 BOLT W/ LOCK NUTS	203-112

# BRAKE ROTORS

## SCALLOPED SINGLE BLADE

- ★SINGLE BLADE WITH NO VANES
- ★SCALLOPED TO ELIMINATE EVEN MORE ROTATING WEIGHT & TO PREVENT WARPING
- ★BUILT FOR RACING
- ★WEIGHS ONLY 5.5 LBS.



DIA.	WIDTH	BOLT CIRCLE	LBS.	PART #
11.75"	.500"	8x7.00"	5.5	203-812

Place your order at (479) 646-6988, Fax to (479) 646-5939, or visit [www.southwestspeed.com](http://www.southwestspeed.com)



# BRAKE ROTORS STRAIGHT VANE

- ★LIGHTWEIGHT DESIGN
- ★PRECISION MACHINED
- ★BUILT FOR RACING
- ★WILWOOD CALLS THIS SERIES "UL"



DIA.	WIDTH	BOLT CIRCLE	LBS.	PART #
11.75"	.810"	8x7.00" (LEFT)*	8.1	203-820
11.75"	.810"	8x7.00" (RIGHT)*	8.1	203-822
11.75"	.810"	8x7.00"	8.1	WIL 160-0471
11.75"	1.250"	8x7.00"	8.8	WIL 160-0483
11.75"	.810"	10x6.80"	9.1	WIL 160-0790
11.75"	1.250"	10x6.80"	9.5	WIL 160-0789

\*PART #203-820 & #203-822 ARE NUMBERED LEFT & RIGHT, BUT ARE THE SAME PART.

# CURVED VANE

- ★CURVED VANES HELP THE BRAKES RUN COOLER
- ★LIGHTWEIGHT DESIGN
- ★PRECISION MACHINED
- ★BUILT FOR RACING
- ★WILWOOD CALLS THIS SERIES "UL-32"



DIA.	WIDTH	BOLT CIRCLE	LBS.	PART #
11.75"	1.250"	8x7.00" (LEFT)	8.7	203-830
11.75"	1.250"	8x7.00" (RIGHT)	8.7	203-832
11.75"	1.250"	8x7.00" (LEFT)	9.6	WIL 160-2899
11.75"	1.250"	8x7.00" (RIGHT)	9.6	WIL 160-2898
12.19"	1.250"	8x7.00" (LEFT)	10.5	WIL 160-2895
12.19"	1.250"	8x7.00" (RIGHT)	10.5	WIL 160-2894

# DRILLED STRAIGHT VANE

- ★DRILLED FOR LOWER ROTATING WEIGHT
- ★MADE FROM HIGH QUALITY, HIGH TEMPERATURE STEEL
- ★PRECISION MACHINED
- ★BUILT FOR RACING
- ★WILWOOD CALLS THIS SERIES "ULD-32"



DIA.	WIDTH	BOLT CIRCLE	LBS.	PART #
11.75"	.810"	8x7.00"	7.2	WIL 160-5863
11.75"	1.250"	8x7.00"	7.7	WIL 160-5864
12.19"	.810"	8x7.00"	8.0	WIL 160-5865

# SCALLOPED STRAIGHT VANE

- ★SCALLOPED FOR LOWER ROTATING WEIGHT
- ★MADE FROM HIGH QUALITY, HIGH TEMPERATURE STEEL
- ★PRECISION MACHINED
- ★BUILT FOR RACING
- ★WILWOOD CALLS THIS SERIES "ULS-32"

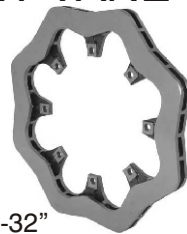

DIA.	WIDTH	BOLT CIRCLE	LBS.	PART #
11.75"	.810"	8x7.00"	5.4	WIL 160-8135
11.75"	1.250"	8x7.00"	6.7	WIL 160-8814

NOTE: SEE PAGE 160 & 161 FOR THE REAR HUBS

# STOCK FRONT HUBS & ROTORS GRANADA STYLE

- ★SOUTHWEST SPEED HUBS & ROTORS ARE ALWAYS DESIGNED TO PREVENT OVERHEATING, DISTORTION, & CRACKING



- ★WILL FIT PERFECTLY ON PINTO SPINDLES (PAGE 60) USING THE COMPLETE BEARING & SEAL KIT (PAGE 66)



- ★ALL COMPLETELY NEW PIECES WITH NEW STUDS & RACES INSTALLED

- ★2ND DESIGN ROTOR (#203-8508) HAS AN OUTBOARD DESIGN & WILL CLEAR THE LOWER A-ARM WITH NO MODIFICATIONS TO EITHER PART



- ★5 X 5" HUBS HAVE 5/8" STUDS, 5 X 4 3/4" HAVE 7/16" STUDS, & 5 X 4 1/2" HAVE 1/2" STUDS

DIA.	WIDTH	BOLT PAT.	LBS.	PART #
10.50"	.810"	5 X 5"	15.70	203-8508
10.50"	.810"	5 X 5"	16.25	203-851
11.00"	.810"	5 X 5"	17.50	203-852
11.00"	1.000"	5 X 4 3/4"	21.44	203-8518
11.00"	1.000"	5 X 4 1/2"	21.54	203-8516

# METRIC STYLE

- ★LIGHTWEIGHT STOCK REPLACEMENT FOR 78-88 GM METRIC FRONT HUBS & ROTORS



- ★FITS METRIC SPINDLES
- ★BRAND NEW PIECE WITH NEW 5/8" COARSE STUDS & RACES INSTALLED

DIA.	WIDTH	BOLT PAT.	LBS.	PART #
10.50"	1.000"	5 X 5"	19.36	203-850

# DUST COVERS

- ★PROTECTS BEARINGS FROM DIRT



DESCRIPTION	PART #
GRANADA DUST COVER, ALUMINUM	201-512
GRANADA DUST COVER, STEEL	201-513
METRIC DUST COVER, STEEL	201-426

NOTE: ALUMINUM CAP REQUIRES DRILLING & TAPPING OF FRONT HUB & ROTOR

Place your order at (479) 646-6988, Fax to (479) 646-5939, or visit [www.southwestspeed.com](http://www.southwestspeed.com)

# MODIFIED HUB, ROTOR, & SPINDLE KITS

- ★CUSTOM DESIGNED LIGHTWEIGHT KITS GIVE YOU ENOUGH PARTS TO DO BOTH FRONT WHEELS
- ★AVAILABLE WITH OR WITHOUT BRAND NEW GM METRIC CALIPERS WITH 2 1/2" PISTONS (2 3/8" & 2 5/8" PISTONS ARE AVAILABLE UPON REQUEST)
- ★COMPLETE KIT WEIGHS ONLY 27 LBS. PER SIDE OR 34 LBS. PER SIDE WITH THE CALIPERS
- ★STRENGTH WILL NEVER BE A PROBLEM WITH THE SOUTHWEST SPEED GRANADA HUBS & ROTORS; THE EXCLUSIVE LIGHTWEIGHT DESIGN STILL MAINTAINS STOCK ROTOR THICKNESS, WHICH WILL PREVENT OVERHEATING, DISTORTION, & CRACKING
- ★BOTH KITS INCLUDE:
  - 2 - PINTO SPINDLES,
  - 2 - 10.5" GRANADA HUBS & ROTORS,
  - 2 - COMPLETE BEARING KITS WITH HUB SEAL, INNER & OUTER WHEEL BEARINGS, SPINDLE NUT, THRUST WASHER, LOCK WASHER, DUST COVER, & COTTER PIN,
  - 2 - PINTO/GM METRIC BRAKE CALIPER BRACKETS,
  - 2 - BRAKE CALIPER BOLT KITS WITH GM CALIPER BOLTS & BOLTS TO PUT THE CALIPER BRACKETS ON THE SPINDLES,
  - 2 - BUMP STEER SPACER KITS WITH SHIMS,
  - 2 - GRADE 8 SPINDLE BOLTS & NUTS

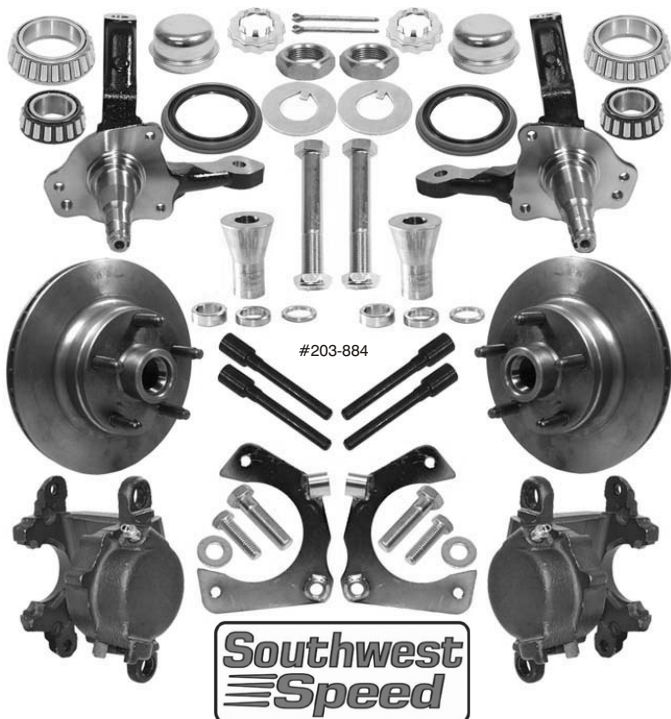

DESCRIPTION	PART #
MODIFIED KIT	203-880
MODIFIED KIT W/ GM METRIC CALIPERS	203-884

# HOT ROD & RESTORATION FRONT BRAKE KITS

- ★CUSTOM DESIGNED KITS FIT TOGETHER PERFECTLY WITHOUT ANY MODIFICATION & GIVES YOU ENOUGH PARTS TO DO BOTH FRONT WHEELS FOR ANY HOT ROD, STREET ROD, OR RESTORATION PROJECT
- ★AVAILABLE WITH STOCK PINTO/MUSTANG II SPINDLES, 2" DROP PINTO/MUSTANG II SPINDLES, OR WITHOUT ANY SPINDLES IN ALL 3 BOLT PATTERNS
- ★ALL KITS BOTH WITH OR WITHOUT SPINDLES INCLUDE:
  - 2 - 11" GRANADA HUBS & ROTORS,
  - 2 - COMPLETE BEARING KITS WITH HUB SEAL, INNER & OUTER WHEEL BEARINGS, SPINDLE NUT, THRUST WASHER, LOCK WASHER, DUST COVER, & COTTER PIN,
  - 2 - BRAND NEW GM METRIC CALIPERS (LEFT & RIGHT),
  - 2 - PINTO/GM METRIC BRAKE CALIPER BRACKETS,
  - 2 - BRAKE CALIPER BOLT KITS

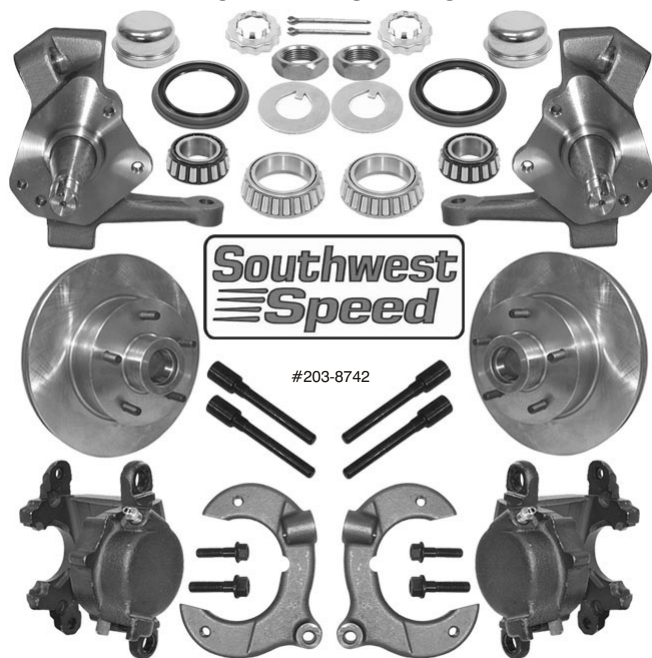

DESC.	BOLT PAT.	SPINDLE	PART #
HOT ROD KIT	5 X 4 1/2"	-	203-870
HOT ROD KIT	5 X 4 1/2"	STOCK	203-871
HOT ROD KIT	5 X 4 1/2"	2" DROP	203-8712
HOT ROD KIT	5 X 4 3/4"	-	203-872
HOT ROD KIT	5 X 4 3/4"	STOCK	203-874
HOT ROD KIT	5 X 4 3/4"	2" DROP	203-8742
HOT ROD KIT	5 X 5"	-	203-876
HOT ROD KIT	5 X 5"	STOCK	203-878
HOT ROD KIT	5 X 5"	2" DROP	203-8782

NOTE: DUE TO THE VARYING APPLICATIONS FOR THESE KITS, ALL BRAKE PADS ARE SOLD SEPARATELY ON PAGE 69

Place your order at (479) 646-6988, Fax to (479) 646-5939, or visit [www.southwestspeed.com](http://www.southwestspeed.com)

# BEARINGS & SEALS GRANADA FRONT HUB & ROTOR

- ★ BEARINGS, SEALS, ETC. TO PUT GRANADA FRONT HUBS & ROTORS ON PINTO/MUSTANG II SPINDLES
- ★ COMPLETE KIT COMES WITH EVERYTHING PICTURED: HUB SEAL, INNER & OUTER WHEEL BEARINGS, SPINDLE NUT, THRUST WASHER, LOCK WASHER, DUST COVER, & COTTER PIN
- ★ SPINDLE NUT & HUBCAP KIT COMES WITH SPINDLE NUT, THRUST WASHER, LOCK WASHER, DUST COVER, & COTTER PIN



DESCRIPTION	PART #
COMPLETE BEARING KIT	201-450
SPINDLE NUT & HUBCAP KIT	201-449
HUB SEAL	201-432
INNER BEARING RACE	201-434
OUTER BEARING RACE	201-436
INNER WHEEL BEARING	201-438
OUTER WHEEL BEARING	201-440
SPINDLE NUT THRUST WASHER	201-442
SPINDLE NUT	201-444
SPINDLE NUT LOCK WASHER	201-445
STEEL DUST COVER	201-513
ALUMINUM DUST COVER, BOLT-ON	201-512

# METRIC FRONT HUB & ROTOR

- ★ BEARINGS, SEALS, ETC. TO PUT METRIC FRONT HUBS & ROTORS ON METRIC SPINDLES
- ★ COMPLETE KIT COMES WITH EVERYTHING PICTURED: HUB SEAL, INNER & OUTER WHEEL BEARINGS, SPINDLE NUT, THRUST WASHER, DUST COVER, & COTTER PIN
- ★ SPINDLE NUT & HUBCAP KIT COMES WITH SPINDLE NUT, THRUST WASHER, DUST COVER, & COTTER PIN



DESCRIPTION	PART #
COMPLETE BEARING KIT	201-430
SPINDLE NUT & HUBCAP KIT	201-429
HUB SEAL	201-412
INNER BEARING RACE	201-414
OUTER BEARING RACE	201-416
INNER WHEEL BEARING	201-418
OUTER WHEEL BEARING	201-420
SPINDLE NUT THRUST WASHER	201-422
SPINDLE NUT	201-424
STEEL DUST COVER	201-426

# DISC BRAKE KITS

- ★ ADAPTS BRAKES TO FACTORY REAR ENDS
- ★ KITS INCLUDE: 2 - 11.75" O.D. BRAKE ROTORS (EITHER .810" OR 1.250" THICK) WITH 8 X 7.00" BOLT CIRCLES, 2 - WELD-ON BRAKE BRACKETS (4 CALIPER PATTERNS AVAILABLE), 2 - 1.960" OFFSET ALUMINUM BRAKE HATS, AND ALL NECESSARY BOLTS & WASHERS FOR BOTH SIDES
- ★ HATS HAVE 3 BOLT PATTERNS: 5 x 4 1/2", 5 x 4 3/4", & 5 x 5"



CALIPER TYPE	ROTOR WIDTH	PART #
BIG GM	.810"	205-105
BIG GM	1.250"	205-106
GM METRIC	.810"	205-110
GM METRIC	1.250"	205-111
DYNALITE	.810"	205-115
DYNALITE	1.250"	205-116
SUPERLITE	.810"	205-120
SUPERLITE	1.250"	205-121

# DISC BRAKE HATS

- ★ LIGHTWEIGHT ALUMINUM CONSTRUCTION
- ★ MADE WITH 3 BOLT PATTERNS: 5 x 4 1/2", 5 x 4 3/4", & 5 x 5"
- ★ FITS ROTORS WITH A 8 x 7.00" BOLT CIRCLE
- ★ 1.96", 1.71", 1.59", & 1.41" OFFSET AVAILABLE (MEASURED INSIDE OF HAT TO ROTOR FACE)



DESCRIPTION	PART #
ALUM. BRAKE HAT, 1.96", OFFSET	WIL 170-0208
ALUM. BRAKE HAT, 1.71", OFFSET	WIL 170-0259
ALUM. BRAKE HAT, 1.59", OFFSET	WIL 170-0317
ALUM. BRAKE HAT, 1.41", OFFSET	WIL 170-0764

# ROTOR BOLT KITS

- ★ 5/16"-18 x 1" COARSE THREAD, ALLEN HEAD BOLTS OR 5/16"-24 x 7/8" FINE THREAD, 12 POINT BOLTS
- ★ COMES W/ EITHER LOCK WASHERS OR LOCK NUTS



DESCRIPTION	PART #
FINE, 8 BOLT W/ LOCK WASHERS	203-104
COARSE, 8 BOLT W/ LOCK WASHERS	203-106
COARSE, 10 BOLT W/ LOCK WASHERS	203-108
COARSE, 8 BOLT W/ LOCK NUTS	203-110
COARSE, 10 BOLT W/ LOCK NUTS	203-112

Place your order at (479) 646-6988, Fax to (479) 646-5939, or visit [www.southwestspeed.com](http://www.southwestspeed.com)



# STEEL BRAIDED HOSES AN TO AN, STRAIGHT

- ★-3 OR -4 AN STEEL BRAIDED HOSE WITH -3 OR -4 AN STRAIGHT STEEL SWIVEL END ON BOTH ENDS

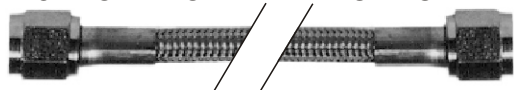

DESCRIPTION	-3AN/-3AN	-4AN/-4AN
12" LONG HOSE	290-9912	291-112
15" LONG HOSE	290-9915	291-115
18" LONG HOSE	290-9918	291-118
21" LONG HOSE	290-9921	291-121
24" LONG HOSE	290-9924	291-124
30" LONG HOSE	290-9930	291-1246
34" LONG HOSE	290-9934	291-1248

# AN 90° TO AN STRAIGHT

- ★90° -3 OR -4 AN SWIVEL END TO STRAIGHT -3 OR -4 AN STEEL SWIVEL END

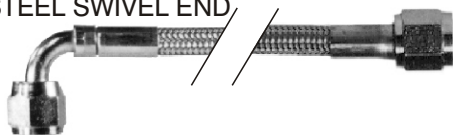

DESCRIPTION	-3AN/-3AN	-4AN/-4AN
12" LONG HOSE	290-9962	291-062
15" LONG HOSE	290-9965	291-065
18" LONG HOSE	290-9968	291-068
21" LONG HOSE	290-9971	291-071
24" LONG HOSE	290-9974	291-074
30" LONG HOSE	290-9980	291-0746
36" LONG HOSE	290-9986	291-0752

# 1/8" NPT TO -4 AN, STRAIGHT

- ★-4 AN STEEL BRAIDED HOSE
- ★1/8" NPT MALE END & -4 AN STEEL SWIVEL END
- ★1/8" NPT TO 3/16" INVERTED FLARE ADAPTER INCLUDED

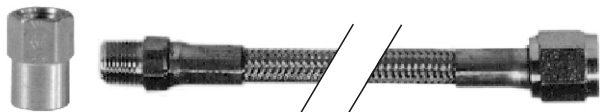

DESCRIPTION	PART #
HOSE, 1/8" NPT TO -4AN, 12" LONG	291-012
HOSE, 1/8" NPT TO -4AN, 15" LONG	291-015
HOSE, 1/8" NPT TO -4AN, 18" LONG	291-018
HOSE, 1/8" NPT TO -4AN, 21" LONG	291-021
HOSE, 1/8" NPT TO -4AN, 24" LONG	291-024

# BANJO TO -4 AN, STRAIGHT

- ★BANJO & -4 AN STEEL SWIVEL END



DESCRIPTION	PART #
BANJO TO -4 AN, 12" LONG	291-032
BANJO TO -4 AN, 15" LONG	291-035
BANJO TO -4 AN, 18" LONG	291-038
BANJO TO -4 AN, 21" LONG	291-041
BANJO TO -4 AN, 24" LONG	291-044

NOTE: SEE PAGE 201 FOR BRAKE LINE TABS

# NYLON LINE KITS

- ★KITS COME COMPLETE WITH ALL COMPRESSION FITTINGS & LINE NECESSARY FOR MOST APPLICATIONS;
- #290-082 ALSO COMES WITH FITTINGS & LINE TO CONNECT TO BRAKE GAUGES
- ★LINE HAS 2500 PSI BURST PRESSURE



DESCRIPTION	PART #
25' KIT, COMPLETE	290-080
30' KIT, COMPLETE W/GAUGE FITTINGS	290-082

# STEEL BRAKE LINES

- ★3/16" INVERTED FLARE FITTINGS
- ★ONE SHORT & ONE LONG FITTING



DESCRIPTION	PART #
3/16" STEEL BRAKE LINE, 8" LONG	290-090
3/16" STEEL BRAKE LINE, 12" LONG	290-091
3/16" STEEL BRAKE LINE, 20" LONG	290-092
3/16" STEEL BRAKE LINE, 30" LONG	290-093
3/16" STEEL BRAKE LINE, 40" LONG	290-094
3/16" STEEL BRAKE LINE, 51" LONG	290-095
3/16" STEEL BRAKE LINE, 60" LONG	290-096
LINE COUPLER, 3/16" INVERTED FLARE	290-099

# BRAKE PAD SPACERS

- ★ALLOWS CALIPERS TO BE USED WITH NARROWER ROTORS



DESCRIPTION	WIDTH	PART #
GM METRIC CALIPER, STEEL	3/16"	203-710
GM METRIC CALIPER, ALUM.	3/8"	203-712
BIG GM CALIPER, ALUMINUM	3/8"	203-714
BIG GM CALIPER, ALUMINUM	1/2"	203-716
BIG GM CALIPER, ALUMINUM	3/4"	203-718

PART #203-710 FITS METRIC BRAKES TO .810" ROTORS  
 PART #203-712 FITS METRIC BRAKES TO 1/2" ROTORS  
 PART #203-714 FITS BIG GM BRAKES TO 7/8" ROTORS  
 PART #203-716 FITS BIG GM BRAKES TO 3/4" ROTORS  
 PART #203-718 FITS BIG GM BRAKES TO 1/2" ROTORS

# GM CALIPER BOLTS

- ★ONE OR TWO PIECE, HEAT TREATED BOLTS
- ★REPLACES STOCK GM BOLTS & WILL WORK WITH GM METRIC & BIG GM CALIPERS
- ★#105-0549 INCLUDES 2 CALIPER BOLTS & THE BOLTS & WASHERS TO PUT A GM METRIC CALIPER BRACKET (#105-055 OR #105-056) ON A PINTO SPINDLE



DESCRIPTION	PART #
1 PIECE CALIPER BOLT	203-099
2 PIECE CALIPER BOLT WITH BUSHING	203-098
PINTO SPINDLE/METRIC CALIPER KIT	105-0549

Place your order at (479) 646-6988, Fax to (479) 646-5939, or visit [www.southwestspeed.com](http://www.southwestspeed.com)

# BRAKE CALIPERS

## GM METRIC - STEEL

- ★100% BRAND NEW CONSTRUCTION
- ★FLOATING DESIGN
- ★AVAILABLE WITH  
2 3/8", 2 1/2" (STOCK),  
& 2 5/8" DIAMETER  
PISTONS
- ★FITS 1.000" THICK  
ROTOR & WILL FIT  
.810" THICK ROTORS BY  
USING #203-710 SPACER (PAGE 67)

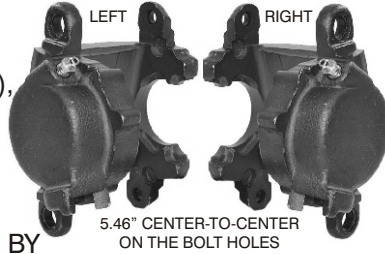

DESCRIPTION	PART #
GM METRIC, LEFT, 2 3/8" PISTON	203-619
GM METRIC, LEFT, 2 1/2" PISTON	203-620
GM METRIC, LEFT, 2 5/8" PISTON	203-6202
GM METRIC, RIGHT, 2 3/8" PISTON	203-621
GM METRIC, RIGHT, 2 1/2" PISTON	203-622
GM METRIC, RIGHT, 2 5/8" PISTON	203-6222

## GM METRIC W/ EMERGENCY BRAKE - STEEL

- ★100% BRAND NEW CONSTRUCTION
- ★SINGLE, STOCK  
2 1/8" PISTON
- ★ACCEPT GM & LOKAR-TYPE  
EMERGENCY BRAKE CABLES
- ★FLUID INLETS ARE 7/16"-20 THREAD

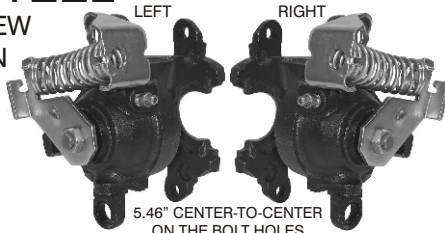

DESCRIPTION	PART #
GM METRIC WITH E-BRAKE, LEFT	203-6205
GM METRIC WITH E-BRAKE, RIGHT	203-6225

## GM METRIC - ALUMINUM

- ★SINGLE 2 3/8" PISTON
- ★LIGHTWEIGHT ALUMINUM CONSTRUCTION  
WEIGHING ONLY 2.97 LBS.
- ★STOCK MOUNTING

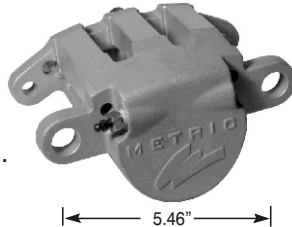

PISTON SIZE	ROTOR WIDTH	ROTOR WIDTH	ROTOR WIDTH
	.810	1.00	1.25
2.38"	WIL 120-6426	WIL 120-7197	WIL 120-6427

## GM III - BIG GM

- ★SINGLE PISTON
- ★LIGHTWEIGHT
- ★BILLET ALUMINUM

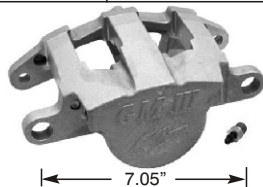

PISTON SIZE	ROTOR WIDTH	ROTOR WIDTH
	.810	1.25
2.38"	WIL 120-5343	WIL 120-5344
2.75"	WIL 120-5288	WIL 120-5289

# BRAKE CALIPERS

- ★MANY SERIES OF CALIPERS  
AVAILABLE, WITH A FEW LISTED  
BELOW; SEE southwestspeed.com  
FOR OUR FULL LIST OF CALIPERS



WILWOOD BRAKE CALIPERS			
DESCRIPTION	PISTON SIZE	ROTOR WIDTH	PART #
<b>FORGED DYNALITE - 4 PISTON, 5.25" BOLT PATTERN</b>			
FDL-BLACK	1.38"	.375"	WIL 120-6808
FDL-BLACK	1.38"	.500"	WIL 120-6807
FDL-BLACK	1.38"	.810"	WIL 120-6806
FDL-BLACK	1.38"	1.00"	WIL 120-6805
FDL-BLACK	1.38"	1.25"	WIL 120-6804
FDL-BLACK	1.62"	.810"	WIL 120-6811
FDL-BLACK	1.75"	.375"	WIL 120-6818
FDL-BLACK	1.75"	.500"	WIL 120-6817
FDL-BLACK	1.75"	.810"	WIL 120-6816
FDL-BLACK	1.75"	1.00"	WIL 120-6815
FDL-BLACK	1.75"	1.25"	WIL 120-6814
FDL-RED	1.38"	.810"	WIL 120-6806-RD
FDL-RED	1.62"	.810"	WIL 120-6811-RD
FDL-RED	1.75"	.810"	WIL 120-6816-RD
FDL-RED	1.75"	.375"	WIL 120-6818-RD
FDL-POLISHED	1.38"	.810"	WIL 120-6791-P
FDL-POLISHED	1.62"	.375"	WIL 120-6798-P
FDL-POLISHED	1.62"	.810"	WIL 120-6796-P
FDL-POLISHED	1.62"	1.00"	WIL 120-6795-P
<b>FORGED SUPERLITE - 4 PISTON, 3.50" PATTERN</b>			
FSLI-BLACK	1.25"	.810"	WIL 120-11126
FSLI-BLACK	1.25"	1.25"	WIL 120-11127
FSLI-BLACK	1.38"	.810"	WIL 120-11128
FSLI-BLACK	1.38"	1.10"	WIL 120-11129
FSLI-BLACK	1.38"	1.25"	WIL 120-11130
FSLI-BLACK	1.62"	.810"	WIL 120-11131
FSLI-BLACK	1.62"	1.10"	WIL 120-11132
FSLI-BLACK	1.62"	1.25"	WIL 120-11133
FSLI-BLACK	1.75"	.810"	WIL 120-11134
FSLI-BLACK	1.75"	1.10"	WIL 120-11135
FSLI-BLACK	1.75"	1.25"	WIL 120-11136
FSLI-BLACK-LEFT	1.88"/1.75"	.810"	WIL 120-11138
FSLI-BLACK-RIGHT	1.88"/1.75"	.810"	WIL 120-11137
FSLI-BLACK-LEFT	1.88"/1.75"	1.25"	WIL 120-11330
FSLI-BLACK-RIGHT	1.88"/1.75"	1.25"	WIL 120-11329
<b>FORGED NARROW DYNALITE - 4 PISTON, 3.50"</b>			
FNDL-BLACK	1.38"	.375"	WIL 120-11574
FNDL-BLACK	1.38"	.810"	WIL 120-11575
FNDL-BLACK	1.38"	1.25"	WIL 120-11576
FNDL-BLACK	1.75"	.375"	WIL 120-11571
FNDL-BLACK	1.75"	.810"	WIL 120-11572
FNDL-BLACK	1.75"	1.25"	WIL 120-11573
<b>DYNAPRO DP6 - 6 PISTON, 5.25" BOLT PATTERN</b>			
DP6-BLACK-LEFT	1.38"/1.00"	.810"	WIL 120-10135
DP6-BLACK-RIGHT	1.38"/1.00"	.810"	WIL 120-10134
DP6-BLACK-LEFT	1.62"/1.12"	.810"	WIL 120-10129
DP6-BLACK-RIGHT	1.62"/1.12"	.810"	WIL 120-10128
DP6-BLACK-LEFT	1.62"/1.38"	.810"	WIL 120-10123
DP6-BLACK-RIGHT	1.62"/1.38"	.810"	WIL 120-10122
DP6-BLACK-LEFT	1.62"/1.38"	1.10"	WIL 120-10121
DP6-BLACK-RIGHT	1.62"/1.38"	1.10"	WIL 120-10120
DP6-RED-LEFT	1.38"/1.00"	.810"	WIL 120-10135RD
DP6-RED-RIGHT	1.38"/1.00"	.810"	WIL 120-10134RD
DP6-RED-LEFT	1.62"/1.12"	.810"	WIL 120-10129RD
DP6-RED-RIGHT	1.62"/1.12"	.810"	WIL 120-10128RD
DP6-RED-LEFT	1.62"/1.38"	.810"	WIL 120-10123RD
DP6-RED-RIGHT	1.62"/1.38"	.810"	WIL 120-10122RD
DP6-RED-LEFT	1.62"/1.38"	1.10"	WIL 120-10121RD
DP6-RED-RIGHT	1.62"/1.38"	1.10"	WIL 120-10120RD

Place your order at (479) 646-6988, Fax to (479) 646-5939, or visit [www.southwestspeed.com](http://www.southwestspeed.com)



# DISC BRAKE PADS

★ALL PADS ARE SOLD 4 PER BOX (ENOUGH TO DO 2 WHEELS)

★HERE IS A CHART TO HELP DETERMINE THE CORRECT PAD FOR YOUR APPLICATION

SEMI-METALLIC
*MEDIUM FRICTION COMPOUND WITH THE FASTEST COLD RESPONSE
*FLAT TORQUE CURVE GIVES CONSISTENT RESPONSE
*USED IN MOST DIRT TRACK APPLICATIONS, INCLUDING MODIFIEDS, LATE MODELS, STREET STOCKS, ETC.
*ALSO USED FOR DISC BRAKE CONVERSIONS ON HOT RODS & MUSCLE CARS
POLYMATRIX B
*MEDIUM-HIGH FRICTION COMPOUND WITH GOOD COLD RESPONSE & A GENTLY RISING FRICTION CURVE AS TEMPERATURE INCREASES
*SMOOTH, PREDICTABLE ENGAGEMENT WITH EXCELLENT CONTROL OVER A WIDE RANGE OF APPLICATIONS
*LONG WEARING PAD IN THE MIDDLE TEMPERATURE RANGES WITH MODERATE WEAR IN SUSTAINED HIGH HEAT CONDITIONS
*EASILY BEDDED WITHOUT ABRASION ON NEW IRON OR STEEL ROTORS
*TRACE ONLY COMPOUND USED IN MOST MAJOR RACING SERIES FOR SEVERE OVAL, ROAD COURSE, & OFF-ROAD SERIES THAT REQUIRE AN AGGRESSIVE RESPONSE & DURABILITY IN THE HIGHEST TEMPERATURE RANGES
POLYMATRIX D
*ONE OF THE HIGHEST COLD FRICTION TORQUE VALUES OF ANY RACE PAD MATERIAL WITH STRONG RESISTANCE TO FADE OR GLAZE DURING PERIODIC SHARP RISES IN ROTOR TEMPERATURE
*FLAT TORQUE CURVE PROVIDES IMMEDIATE, PREDICTABLE PEDAL RESPONSE & SUPERIOR MODULATION CHARACTERISTICS THROUGHOUT THE ENTIRE TEMPERATURE RANGE
*MAKES AN EXCELLENT CHOICE FOR LIGHT TO MODERATE BRAKING DIRT TRACKS, DRAG RACING, & PERFORMANCE STREET CATEGORY COMPETITION
*DIRT TRACK RACERS ENJOY THE POSITIVE RESPONSE & SMOOTH ENGAGEMENT QUALITIES THAT WON'T UPSET THE CAR DURING LIGHT BRAKING ON DRY-SLICK RACE TRACKS
POLYMATRIX E
*MEDIUM FRICTION COMPOUND WITH THE HIGHEST EFFECTIVE RANGE IN THE MEDIUM TEMPERATURE PAD GROUP
*SMOOTH ENGAGEMENT WITH CONSISTENT RESPONSE FROM A FLAT TORQUE CURVE THROUGHOUT ITS ENTIRE EFFECTIVE TEMPERATURE RANGE
*BEST OVERALL WEAR PROPERTIES IN THE MEDIUM TEMP. PAD GROUP
*BEDS QUICKLY AND PROVIDES FAST RESPONSE WITHOUT EXCESSIVE ABRASION ON IRON OR STEEL ROTORS
*USED IN MOST DIRT TRACK APPLICATIONS INCLUDING LATE MODELS, MODIFIEDS, ETC., AS WELL AS LIGHT TO MEDIUM DUTY ROAD RACING & TRACK DAY EVENTS, DRAG RACING WITH IRON OR STEEL ROTORS, AND PERFORMANCE STREET CATEGORY COMPETITION
"SMART PAD" BP-10
*MEDIUM FRICTION COMPOUND WITH THE LOW NOISE & LOW DUST OF A STREET PERFORMANCE COMPOUND & THE INCREASED FRICTION CHARACTERISTICS OF A SEMI-METALLIC RACE COMPOUND
*SMOOTH ENGAGEMENT WITH CONSISTENT RESPONSE FROM A FLAT TORQUE CURVE THROUGHOUT ITS ENTIRE EFFECTIVE TEMPERATURE RANGE
*GOOD LOW TO MIDDLE TEMPERATURE WEAR RATES
*BEDS QUICKLY & PROVIDES FAST RESPONSE WITHOUT EXCESSIVE ABRASION ON VENTED IRON ROTORS
*USED IN HIGH PERFORMANCE STREET / STRIP, DRAG RACE, & TRACK DAY CATEGORIES USING VENTED IRON ROTORS, AS WELL AS FOR LIGHT TO MEDIUM BRAKING ON DIRT TRACKS, INCLUDING LATE MODELS, MODIFIEDS, SPORTSMAN, & STREET STOCKS
*ALSO USED FOR DISC BRAKE CONVERSIONS ON HOT RODS & MUSCLE CARS

## GM METRIC

★SOLD 4 PER BOX

DESCRIPTION	PART #
SEMI-METALLIC	203-602
POLYMATRIX B	WIL 15B-3998K
POLYMATRIX D	WIL 15D-4335K
POLYMATRIX E	WIL 15E-6103K
SMART PAD BP-10	WIL 150-8936K



## GRAND NATIONAL

★SOLD 4 PER BOX  
 ★FERODO DS-11, SUPER SPEEDWAY BRAKE PADS  
 ★FITS 6 PISTON H/A & WILWOOD GN CALIPERS  
 ★HIGH HEAT/NO FADE  
**PART #SCP FRP-503**

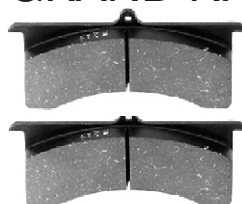

# DISC BRAKE PADS

## BIG GM

★SOLD 4 PER BOX

★FITS BIG GM, GM II, & GM III CALIPERS

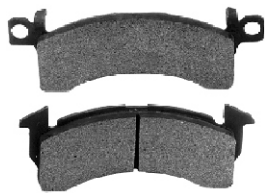

DESCRIPTION	PART #
SEMI-METALLIC	203-600
POLYMATRIX B	WIL 15B-3994K
POLYMATRIX D	WIL 15D-4334K
POLYMATRIX E	WIL 15E-6102K
SMART PAD BP-10	WIL 150-8939K

## DYNALITE & FORGED BILLET DYNALITE

★SOLD 4 PER BOX

DESCRIPTION	PART #
POLYMATRIX B	WIL 15B-3991K
POLYMATRIX D	WIL 15D-4331K
POLYMATRIX E	WIL 15E-6096K
SMART PAD BP-10	WIL 150-8850K
FERODO, HARD	SCP FRP-502

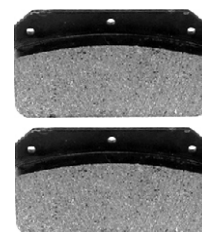

## DYNAPRO 6 PISTON

★SOLD 4 PER BOX



DESCRIPTION	PART #
POLYMATRIX A	WIL15A-10724K
POLYMATRIX B	WIL15B-10725K
POLYMATRIX E	WIL15E-12605K
SMART PAD BP-10	WIL150-10006K
SMART PAD BP-20	WIL150-10007K

## SUPERLITE

★SOLD 4 PER BOX

★FITS SUPERLITE, SUPERLITE II, SUPERLITE III, & LC-GT CALIPERS

DESCRIPTION	PART #
POLYMATRIX B	WIL 15B-3992K
POLYMATRIX D	WIL 15D-4332K
POLYMATRIX E	WIL 15E-6100K
SMART PAD BP-10	WIL 150-8856K

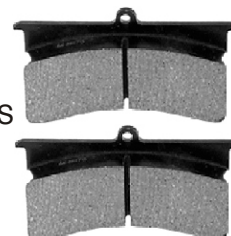

## FORGED BILLET SUPERLITE

★SOLD 4 PER BOX

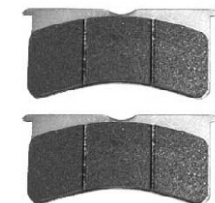

DESCRIPTION	PART #
POLYMATRIX B	WIL 15B-5939K
POLYMATRIX E	WIL 15E-6084K
SMART PAD BP-10	WIL 150-8854K

## NDL/NDP - NARROW DYNALITE/DYNAPRO

★SOLD 4 PER BOX

★FITS NARROW DYNALITE & NARROW DYNAPRO CALIPERS

DESCRIPTION	PART #
POLYMATRIX B	WIL 15B-7264K
POLYMATRIX E	WIL 15E-7266K
SMART PAD BP-10	WIL 150-8946K
SMART PAD BP-20	WIL 150-9419K



Place your order at (479) 646-6988, Fax to (479) 646-5939, or visit [www.southwestspeed.com](http://www.southwestspeed.com)



# GM METRIC CALIPER, PAD, & BRACKET KITS

- ★KITS ARE DESIGNED TO PUT GM METRIC BRAKES ON 9" FORD, FLOATER REAR ENDS
- ★KITS INCLUDE: 2 - BRAND NEW CALIPERS, 2 - BRAKE BRACKETS, 4 - SEMI-METALLIC BRAKE PADS, 4 - CALIPER BOLTS, & 2 - CALIPER SPACERS
- ★AVAILABLE WITH WELD-ON & CLAMP-ON BRACKETS; CLAMP-ON AVAILABLE W/ BOTH 1 1/2" & 2 1/4" WIDE COLLARS

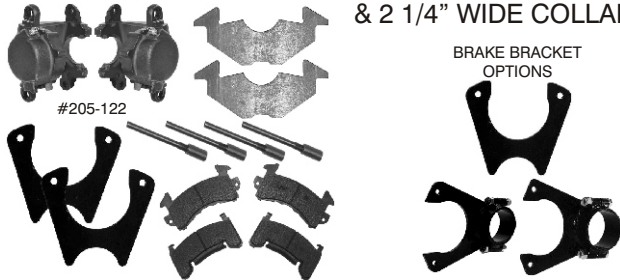

DESCRIPTION	PART #
METRIC REAR KIT, WELD-ON	205-122
METRIC REAR KIT, CLAMP-ON, 1 1/2"	205-123
METRIC REAR KIT, CLAMP-ON, 2 1/4"	205-124

# BRAKE FLOATERS

- ★FIT 3" O.D. TUBES
- ★DUAL ADJUSTMENTS
- ★ISOLATES BRAKE FORCES
- ★AVAILABLE WITH 5/8" & 3/4" THROUGH HOLES
- ★\*NOW AVAILABLE WITH ROLLER BEARINGS



BRACKET	SIDE	HOLES	STEEL	ALUM.
GM METRIC	LEFT	5/8"	570-417	-
GM METRIC*	LEFT	5/8"	570-4172	-
GM METRIC	LEFT	3/4"	570-418	570-420
GM METRIC*	LEFT	3/4"	570-4182	-
GM METRIC	RIGHT	5/8"	570-421	-
GM METRIC*	RIGHT	5/8"	570-4212	-
GM METRIC	RIGHT	3/4"	570-422	570-424
GM METRIC*	RIGHT	3/4"	570-4222	-
BIG GM	LEFT	3/4"	570-410	570-412
BIG GM	RIGHT	3/4"	570-414	570-416
DYNALITE	LEFT	3/4"	570-394	570-396
DYNALITE	RIGHT	3/4"	570-398	570-400
SUPERLITE	LEFT	3/4"	570-402	570-404
SUPERLITE	RIGHT	3/4"	570-406	570-408

# RESIDUAL VALVES

- ★LIGHTWEIGHT ALUMINUM
- ★IN-LINE PRESSURE VALVES RETAIN A MINIMUM BRAKE LINE PRESSURE TO HELP ELIMINATE EXCESSIVE PEDAL TRAVEL IN EITHER DISC OR DRUM BRAKING SYSTEMS



DESCRIPTION	PART #
DISC BRAKE, 1/8" NPT, 2 LB.	WIL 260-1874
DRUM BRAKE, 1/8" NPT, 10 LB.	WIL 260-1876

NOTE: FOR A CONSTANT STREAM OF NEW PRODUCTS & UP-TO-THE-SECOND PRICING, VISIT [WWW.SOUTHWESTSPEED.COM](http://WWW.SOUTHWESTSPEED.COM)

# BRAKE SHUTOFFS

- ★VALVES ARE USED TO SHUT THE BRAKES OFF
- ★3/16" NPT LINE FITTINGS
- ★THESE ARE FOR RACING PURPOSES ONLY
- ★NOT LINE LOCKS & NOT FOR STREET USE

## MANUAL

- ★EASY INSTALLATION
- ★COMPACT DESIGN

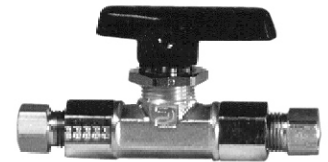

PART #300-099

## ELECTRIC

- ★THE LEAD WIRES SHOULD BE CONNECTED TO A 12 VOLT, 5 AMP (RECOMMENDED) FUSED POWER SOURCE THROUGH A TOGGLE SWITCH
- ★COMPACT DESIGN ALLOWS SHUT-OFF TO BE HIDDEN AWAY



PART #WIL 260-9921

# PROPORTIONING VALVES

- ★ALLOW YOU TO TUNE FRONT & REAR BRAKING BALANCE BY PROPORTIONATELY DECREASING THE REAR (OR IN SOME CASES, FRONT) BRAKE LINE PRESSURE; CAN ALSO BE USED TO ADJUST INDIVIDUAL FRONT WHEEL BRAKING

## 6 POSITION-LEVER TYPE

- ★LIGHTWEIGHT ALUMINUM CONSTRUCTION
- ★FEATURES 6 PRESET ADJUSTMENT POINTS
- ★ADJUSTABLE 100% TO 50%
- ★3/16" LINE FITTINGS



PART # WIL 260-8420

## VARIABLE KNOB TYPE

- ★LIGHTWEIGHT ALUMINUM
- ★KNOB W/ FINE THREAD TUNING PROVIDES PRECISE PRESSURE ADJUSTMENTS
- ★ADJUSTABLE 100% TO 20%
- ★3/16" LINE FITTINGS



PART # WIL 260-8419

## ADJUSTABLE COMBO TYPE

- ★SIMPLIFIES MOUNTING, FLUID CIRCUIT PLUMBING, BRAKE LIGHT WIRING, & BRAKE BIAS ADJUSTMENT
- ★MAINTAINS FULL SEPARATION BETWEEN FRONT & REAR FLUID CIRCUITS
- ★THE VALVE ITSELF WILL MOUNT IN SOME STOCK LOCATIONS
- ★IT IS ALSO AVAILABLE WITH THE MOUNTING BRACKET & LINES TO CONNECT IT TO THE WILWOOD TANDEM CHAMBER CYLINDERS

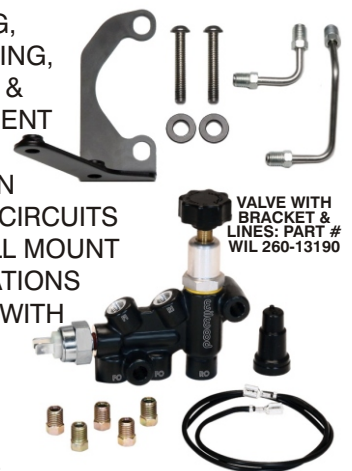

VALVE ONLY: PART #WIL 260-11179

Place your order at (479) 646-6988, Fax to (479) 646-5939, or visit [www.southwestspeed.com](http://www.southwestspeed.com)

# ANTI-LOCK BRAKE KIT

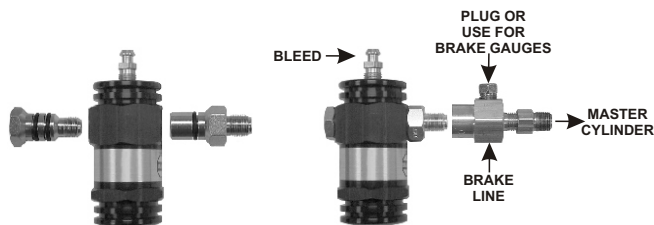

**PART #290-600**

STANDARD INSTALLATION WITH BRAKE KIT

- ★PREVENTS LOCKING WHEELS
- ★HELPS KEEP CONTROL OF CAR UNDER HEAVY BRAKING
- ★ELIMINATES ERRATIC BRAKING FOR SMOOTH CORNER ENTRY
- ★KIT COMES COMPLETE WITH 2 ANTI-LOCK BRAKE CYLINDERS; ONE FOR THE FRONT & ONE FOR THE REAR
- ★ADAPTS TO MANY DIFFERENT BRAKE CONFIGURATIONS

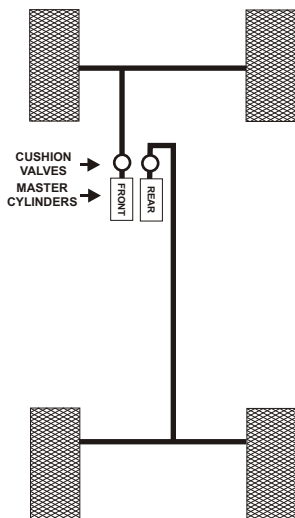

INSTALLATION WITH BRAKE KIT & WITH GAUGES

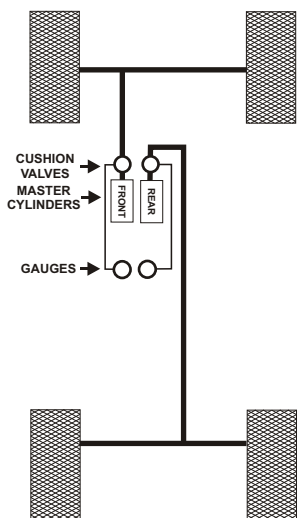

INSTALLATION WITH BRAKE KIT SHUT-OFF

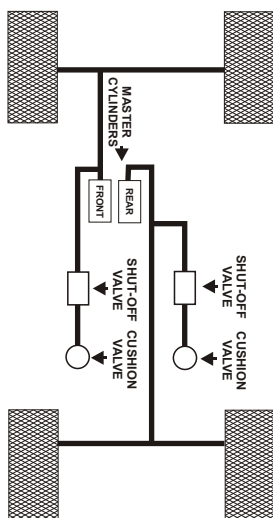

# PREMIUM DOT 3 BRAKE FLUID

- ★EXCEEDS THE HIGHEST STANDARDS OF PERFORMANCE AND SAFETY FOR DOT 3 FLUID
- ★COMES IN 12 OUNCE BOTTLE

**PART #940-010**



# BRAKE CRANKS

## CRANK TYPE

- ★POSITIVE CABLE TYPE ADJUSTER
- ★ADJUSTS FRONT TO REAR BIAS
- ★FITS ALL 3/8"-24 BALANCE BARS



DESCRIPTION	PART #
28" BRAKE CRANK, 18" x 10"	300-092
30" BRAKE CRANK, 18" x 12"	300-0925
35" BRAKE CRANK, 21" x 14"	300-093

NOTE: THE MEASUREMENTS AT THE END OF THE DESCRIPTIONS REPRESENT TUBE LENGTH x FLEX CABLE LENGTH

## KNOB TYPE



- ★ADJUSTS FRONT TO REAR BIAS
- ★ADJUSTABLE LENGTH TO 72"
- ★FITS ALL 3/8" -24 BALANCE BARS

**PART #300-097**

# BRAKE GAUGES

- ★0 TO 2000 PSI
- ★INSTANT PRESSURE
- ★2 5/8" DIAMETER GAUGE FACES
- ★INCLUDES BLEEDER FITTINGS & 1/8" NPT TEE FITTINGS
- ★INDIVIDUAL GAUGES AVAILABLE (#390-193)



**PART #390-195**

# MINI BRAKE GAUGES



- ★0 TO 1500 PSI FRONT & REAR
- ★LIQUID FILLED TO STEADY NEEDLE FUNCTION
- ★1 1/2" DIAMETER GAUGE FACES
- ★INCLUDES 2 BLEEDERS AT THE BACK OF GAUGE FOR EASY BLEEDING

**PART #390-192**

SEE PAGE 188 FOR DELUXE GAUGE & PANEL KITS WITH GAUGE PANELS, BRAKE GAUGES, SWITCH PANELS, & BATTERY DISCONNECTS

# WILWOOD DOT 3 BRAKE FLUID

- ★RACING QUALITY
- ★HIGH TEMPERATURE
- ★570 DRY BOILING POINT
- ★DOT 3 NON-SILICON
- ★COMES IN 12 OZ. PLASTIC BOTTLES
- ★SOLD BY THE BOTTLE OR CASE



DESCRIPTION	PART #
12 OZ. BOTTLE	WIL 290-0632
24 - 12 OZ. BOTTLES (CASE)	WIL 290-0633

Place your order at (479) 646-6988, Fax to (479) 646-5939, or visit [www.southwestspeed.com](http://www.southwestspeed.com)

## BRAKE & CLUTCH PEDALS REVERSE SWING MOUNT

- ★ FEATURES BALANCE BAR FOR ADJUSTING BRAKE BIAS
- ★ LIGHTWEIGHT ALL ALUMINUM CONSTRUCTION
- ★ AVAILABLE IN SOUTHWEST SPEED & WILWOOD BRANDS
- ★ SHORT DESIGN, 5:1 RATIO (10.02") & LONG DESIGN, 6.25:1 RATIO (11.71") AVAILABLE
- ★ THE LONG DESIGN IS ALSO AVAILABLE WITH ADJUSTABLE PEDAL PADS

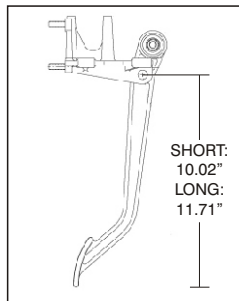
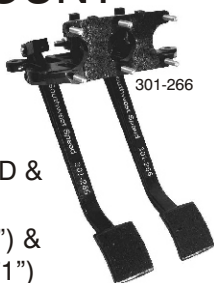

DESCRIPTION	PART #
REV. MOUNT PEDAL ASSY., SHORT	301-266
REV. MOUNT PEDAL ASSY., SHORT	WIL 340-4828
REV. MOUNT PEDAL ASSY., LONG	301-268
REV. MOUNT PEDAL ASSY., LONG	WIL 340-3342
LONG W/ ADJUSTABLE PEDAL PAD	WIL 340-11299
SHORT PEDALS W/ 3 CYLINDERS	301-2663
SHORT PEDALS W/ 3 CYLINDERS	WIL 340-4828x3
LONG PEDALS W/ 3 CYLINDERS	301-2683
LONG PEDALS W/ 3 CYLINDERS	WIL 340-3342x3
BALANCE BAR ASSY	301-2750
BALANCE BAR ASSY W/WELD TUBE	301-2751

## BRAKE, CLUTCH & GAS PEDAL SETS FORWARD FLOOR MOUNT

- ★ TRIPLE PEDAL ASSEMBLY **Master Cylinders Not Included**
- ★ AVAILABLE WITH A THROTTLE BELL CRANK & LINKAGE FOR FRONT ENGINE APPLICATIONS AND W/O THAT FOR REAR ENGINE APPLICATIONS
- ★ BALANCE BAR FOR ADJUSTING BRAKE BIAS
- ★ LIGHTWEIGHT ALL ALUMINUM FRAME & FABRICATED STEEL PEDALS
- ★ 5.25:1 RATIO ON BRAKE & CLUTCH PEDALS
- ★ LINKAGE AVAILABLE BY ITSELF AS WELL



DESCRIPTION	PART #
PEDAL ASSY FOR REAR ENGINE	WIL 340-12410
PEDAL ASSY FOR FRONT ENGINE	WIL 340-12411
THROTTLE LINKAGE ONLY	WIL 340-12412

## BRAKE & CLUTCH PEDALS FORWARD SWING MOUNT

- ★ FEATURES BALANCE BAR FOR ADJUSTING BRAKE BIAS
- ★ LIGHTWEIGHT ALL ALUMINUM CONSTRUCTION
- ★ WILWOOD LONG DESIGN, 6.25:1 RATIO FOR FORWARD MOUNT MASTER CYLINDERS
- ★ AVAILABLE WITH ADJUSTABLE

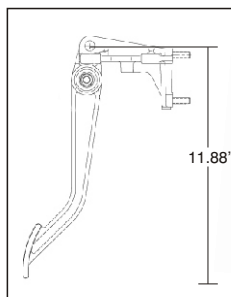

DESCRIPTION	PART #
FORWARD MOUNT PEDAL ASSY.	WIL 340-3950
ASSY W/ ADJUSTABLE PEDAL PAD	WIL 340-11295
PEDALS W/ 3 MASTER CYLINDERS	WIL 340-3950x3
BALANCE BAR ASSY	301-2750
BALANCE BAR ASSY W/WELD TUBE	301-2751

## BRAKE PEDALS FORWARD FLOOR MOUNT

- ★ ACCEPTS DUAL MASTER CYLINDERS
- ★ FEATURES BALANCE BAR FOR ADJUSTING BRAKE BIAS
- ★ LIGHTWEIGHT ALL ALUMINUM CONSTRUCTION
- ★ AVAILABLE IN SOUTHWEST SPEED & WILWOOD BRANDS
- ★ SHORT DESIGN, 6:1 RATIO

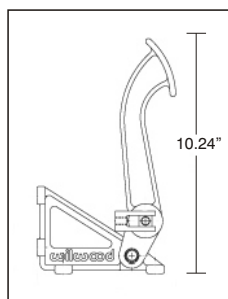

DESCRIPTION	PART #
BRAKE PEDAL, FLOOR MOUNT	301-258
BRAKE PEDAL, FLOOR MOUNT	WIL 340-1285
PEDAL W/ 2 MASTER CYLINDERS	301-2582
PEDAL W/ 2 MASTER CYLINDERS	WIL 340-1285x2
BALANCE BAR ASSY	301-2750
BALANCE BAR ASSY W/WELD TUBE	301-2751

Place your order at (479) 646-6988, Fax to (479) 646-5939, or visit [www.southwestspeed.com](http://www.southwestspeed.com)



# BRAKE PEDALS

## FORWARD SWING MOUNT

- ★ ACCEPTS DUAL MASTER CYLINDERS
- ★ FEATURES BALANCE BAR FOR ADJUSTING BRAKE BIAS
- ★ LIGHTWEIGHT ALL ALUMINUM CONSTRUCTION
- ★ AVAILABLE IN SOUTHWEST SPEED & WILWOOD BRANDS
- ★ LONG DESIGN, 7:1 RATIO

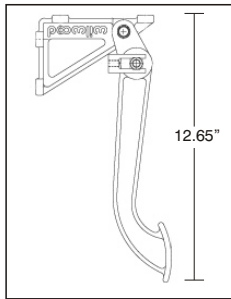

DESCRIPTION	PART #
BRAKE PEDAL, SWING MOUNT	301-260
BRAKE PEDAL, SWING MOUNT	WIL 340-1287
PEDAL W/ 2 MASTER CYLINDERS	301-2602
PEDAL W/ 2 MASTER CYLINDERS	WIL 340-1287x2
BALANCE BAR ASSY	301-2750
BALANCE BAR ASSY W/WELD TUBE	301-2751

# REVERSE SWING MOUNT

- ★ FEATURES BALANCE BAR FOR ADJUSTING BRAKE BIAS
- ★ LIGHTWEIGHT ALL ALUMINUM CONSTRUCTION
- ★ SHORT DESIGN, 5:1 RATIO (10.02") & LONG DESIGN, 6.25:1 RATIO (11.71") AVAILABLE

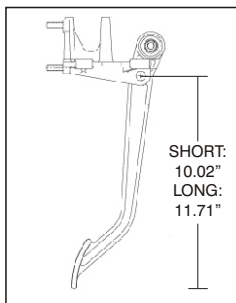

DESCRIPTION	PART #
REV. MOUNT BRAKE PEDAL, SHORT	WIL 340-5180
REV. MOUNT BRAKE PEDAL, LONG	WIL 340-5181
PEDAL W/ 2 CYLINDERS, SHORT	WIL 340-5180x2
PEDAL W/ 2 CYLINDERS, LONG	WIL 340-5181x2
BALANCE BAR ASSY	301-2750
BALANCE BAR ASSY W/WELD TUBE	301-2751

# CLUTCH PEDALS

## FORWARD FLOOR MOUNT

- ★ SINGLE MASTER CYLINDER DESIGN
- ★ LIGHTWEIGHT ALUMINUM
- ★ AVAILABLE IN SOUTHWEST SPEED & WILWOOD BRANDS
- ★ SHORT DESIGN, 6:1 RATIO

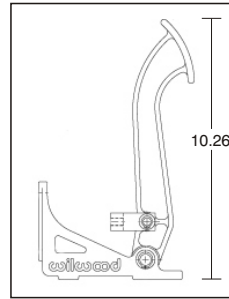

DESCRIPTION	PART #
CLUTCH PEDAL, FLOOR MOUNT	301-257
CLUTCH PEDAL, FLOOR MOUNT	WIL 340-1289
PEDAL W/ 3/4" MASTER CYLINDER	301-2571
CLUTCH PEDAL KIT, FLOOR*	301-2574
CLUTCH PEDAL KIT, FLOOR*	WIL 340-1469

\*CLUTCH PEDAL KIT INCLUDES PEDAL, 3/4" MASTER CYLINDER, & SLAVE CYLINDER

# FORWARD SWING MOUNT

- ★ SINGLE MASTER CYLINDER DESIGN
- ★ LIGHTWEIGHT ALL ALUMINUM CONSTRUCTION
- ★ AVAILABLE IN SOUTHWEST SPEED & WILWOOD BRANDS
- ★ LONG DESIGN, 7:1 RATIO

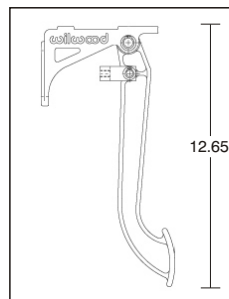

DESCRIPTION	PART #
CLUTCH PEDAL, SWING MOUNT	301-259
CLUTCH PEDAL, SWING MOUNT	WIL 340-1290
PEDAL W/ 3/4" MASTER CYLINDER	301-2591
CLUTCH PEDAL KIT, SWING*	301-2594
CLUTCH PEDAL KIT, SWING*	WIL 340-1470

\*CLUTCH PEDAL KIT INCLUDES PEDAL, 3/4" MASTER CYLINDER, & SLAVE CYLINDER

NOTE: WHEN USING A MINI-CLUTCH, IT IS RECOMMENDED THAT CLUTCH PEDALS NOT BE USED WITH ANY MASTER CYLINDER WITH A BORE LARGER THAN 3/4" FOR PROPER THROWOUT BEARING & CLUTCH USAGE.

Place your order at (479) 646-6988, Fax to (479) 646-5939, or visit [www.southwestspeed.com](http://www.southwestspeed.com)

# BRAKE & CLUTCH PEDAL MOUNTS

## SEPARATE PEDALS

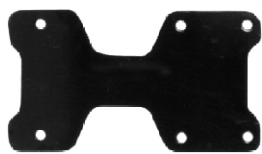

- ★10 GAUGE STEEL
  - ★USED TO MOUNT INDIVIDUAL BRAKE & CLUTCH PEDALS TOGETHER
- PART #301-250**

## COMBINATION PEDALS

- ★MOUNTS FORWARD OR REVERSE MOUNT COMBINATION BRAKE & CLUTCH PEDALS
- ★ADJUSTABLE, WELD-ON DESIGN

**PART #301-256**



# MASTER CYLINDERS

## WILWOOD - TANDEM CHAMBER

- ★DUAL OUTLET, ALUMINUM TANDEM CHAMBER MASTER CYLINDERS
- ★THESE CYLINDERS REPRESENT THE LATEST REFINEMENTS IN BRAKE PRESSURE ACTUATION AND FLUID CONTROL
- ★MOUNTING FLANGE IS SLOTTED TO ACCEPT BOLT CENTERS FROM 3.22" - 3.40", WHICH ENCOMPASSES MOST STOCK PATTERNS
- ★INCLUDES SEVERAL FITTINGS TO ADAPT TO MOST STOCK LINES AS WELL



DESCRIPTION	PART #
TANDEM M/C, 7/8" BORE	WIL 260-9439
TANDEM M/C, 7/8" BORE, BLACK	WIL 260-9439-BK
TANDEM M/C, 7/8" BORE, POLISH	WIL 260-9439-P
TANDEM M/C, 1" BORE	WIL 260-8555
TANDEM M/C, 1" BORE, BLACK	WIL 260-8555-BK
TANDEM M/C, 1" BORE, POLISH	WIL 260-8555-P
TANDEM M/C, 1 1/8" BORE	WIL 260-8556
TANDEM M/C, 1 1/8" BORE, BLACK	WIL 260-8556-BK
TANDEM M/C, 1 1/8" BORE, POLISH	WIL 260-8556-P

## MCP - OPEN WHEEL & KARTING

- ★HIGH PERFORMANCE CYLINDERS WITH ETHYL PROPYLENE SEALS, WHICH ALLOWS THEM TO BE USED WITH DOT 3, 4, OR 5 FLUIDS
- ★COMMONLY USED ON MINI & MICRO SPRINTS, TQ's, KARTS, ETC



DESCRIPTION	PART #
MCP 3/4" BORE WITH EP SEALS, RED	MCP 750
MCP 3/4" BORE W/ EP SEALS, BLACK	MCP 750B
MCP 3/4" BORE W/ EP SEALS, SILVER	MCP 750C
MCP 7/8" BORE W/ EP SEALS, BLACK	MCP 875EP

# MASTER CYLINDERS

## SOUTHWEST SPEED - ALUMINUM

- ★HIGH VOLUME ALUMINUM MASTER CYLINDERS
- ★DIE-CAST FROM HIGH-GRADE ALUMINUM; FULLY MACHINED & ASSEMBLED WITH EXTREME PRECISION
- ★FIT SOUTHWEST SPEED, WILWOOD, HOWE, & MOST OTHER RACING PEDALS

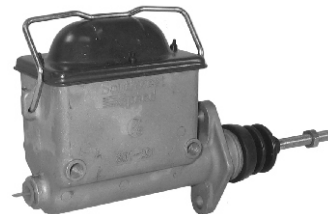

DESCRIPTION	PART #
3/4" BORE, ALUMINUM CYLINDER	301-290
7/8" BORE, ALUMINUM CYLINDER	301-291
1" BORE, ALUMINUM CYLINDER	301-292

## WILWOOD - ALUMINUM

- ★HIGH-VOLUME ALUMINUM CYLINDERS
- ★FIT SOUTHWEST SPEED, WILWOOD, HOWE, & MOST OTHER RACING PEDALS

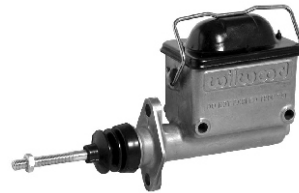

DESCRIPTION	PART #
3/4" BORE, ALUMINUM CYLINDER	WIL 260-6764
7/8" BORE, ALUMINUM CYLINDER	WIL 260-6765
1" BORE, ALUMINUM CYLINDER	WIL 260-6766

## GIRLING TYPE - ALUMINUM

- ★LIGHTWEIGHT ALUMINUM CONSTRUCTION
- ★3/8"-24 OUTLET
- ★FIT ALL POPULAR RACING PEDALS



DESCRIPTION	PART #
5/8" BORE, ALUMINUM, GIRLING	290-411
3/4" BORE, ALUMINUM, GIRLING	290-412
7/8" BORE, ALUMINUM, GIRLING	290-4121
GIRLING MASTER CYLINDER LID ONLY	290-420
FITTING, 3/8"-24 MALE TO 3/16" LINE FEM.	301-088

## WILWOOD - REMOTE RESERVOIR

- ★PRECISION MACHINED FROM HIGH-STRENGTH ALUMINUM
- ★INCLUDES BOTH SMALL & LARGE RESERVOIRS, WHICH CAN BE MOUNTED DIRECTLY ON THE MASTER CYLINDERS OR REMOTELY MOUNTED FOR MORE CONVENIENT ACCESS

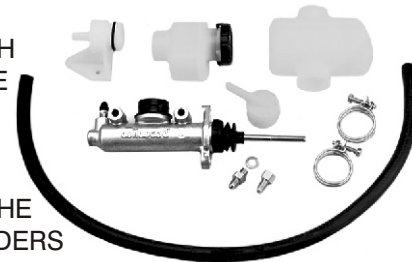

DESCRIPTION	PART #
5/8" BORE, REMOTE RESERVOIR	WIL 260-3372
3/4" BORE, REMOTE RESERVOIR	WIL 260-3374
7/8" BORE, REMOTE RESERVOIR	WIL 260-3376
1" BORE, REMOTE RESERVOIR	WIL 260-3378

Place your order at (479) 646-6988, Fax to (479) 646-5939, or visit [www.southwestspeed.com](http://www.southwestspeed.com)

# MASTER CYLINDER REPAIR KITS SOUTHWEST SPEED - ALUMINUM

DESCRIPTION	PART #
REBUILD KIT*, 3/4" BORE	301-2880
REBUILD KIT*, 7/8" BORE	301-2881
REBUILD KIT*, 1" BORE	301-2882
PISTON & SPRING, 3/4" BORE	301-2870
PISTON & SPRING, 7/8" BORE	301-2871
PISTON & SPRING, 1" BORE	301-2872
DUST BOOT	301-2864
PISTON RETAINING SNAP RING	301-2865
PISTON RETAINING WASHER	301-2866
PUSH ROD	301-2867
LID	301-2861
LID GASKET	301-2862
LID WIRE	301-2863

\*REBUILD KIT CONTAINS PISTON, SPRING, DUST BOOT, & PISTON RETAINING RING

## WILWOOD - ALUMINUM

DESCRIPTION	PART #
REBUILD KIT*, 3/4" BORE	WIL 260-6898
REBUILD KIT*, 7/8" BORE	WIL 260-6899
REBUILD KIT*, 1" BORE	WIL 260-6900
DUST BOOT	WIL 210-1090
PUSH ROD	301-2867
LID	WIL 330-6724
LID GASKET	WIL 210-6725
LID & LID GASKET	WIL 330-7085
LID WIRE	WIL 300-1843

\*REBUILD KIT CONTAINS PISTON, SPRING, DUST BOOT, PISTON RETAINING SNAP RING, PISTON RETAINING WASHER, LID GASKET, & PUSH ROD

## HOWE - ALUMINUM

DESCRIPTION	PART #
REBUILD KIT*, 3/4" BORE	300-112
REBUILD KIT*, 7/8" BORE	300-114
REBUILD KIT*, 1" BORE	300-116
REBUILD KIT*, 1 1/8" BORE	HRE 524-18K
RESIDUAL VALVE KIT, 3/4" BORE	HRE 524-12RV
RESIDUAL VALVE KIT, 7/8" BORE	HRE 524-14RV
RESIDUAL VALVE KIT, 1" BORE	HRE 524-16RV
DUST BOOT	301-2864
PUSH ROD	301-2867
LID	301-2861
LID GASKET	301-2862
LID WIRE	HRE 524W

\*REBUILD KIT CONTAINS PISTON, SPRING, & PISTON RETAINING SNAP RING

## WILWOOD - REMOTE RESERVOIR

DESCRIPTION	PART #
REBUILD KIT*, 3/4" BORE	WIL 260-3881
REBUILD KIT*, 7/8" BORE	WIL 260-3882
REBUILD KIT*, 1" BORE	WIL 260-3883
SMALL RESERVOIR	WIL 260-3386
LARGE RESERVOIR	WIL 260-3390
RESERVOIR CAP	WIL 260-3392
RESERVOIR O-RING	WIL 210-3397
RESERVOIR INLET	WIL 260-3396
MOUNTING BRACKET	WIL 250-3381

\*REBUILD KIT CONTAINS PISTON, SPRING, DUST BOOT, PISTON RETAINING SNAP RING, & RESERVOIR O-RINGS

# SLAVE CYLINDER

- ★PULLING TYPE SLAVE CYLINDER
- ★LIGHTWEIGHT ALUMINUM
- ★TAPPED 1/8" NPT INLET
- ★INCLUDES 1/8" NPT MALE TO 3/16" LINE FEMALE FITTINGS



DESCRIPTION	PART #
PULLING SLAVE CYL., COMPLETE	650-405
SLAVE CYL. 1/2 ROUND WASHER	650-409
SLAVE CYL. REBUILD KIT	WIL 260-1335
SLAVE CYL. REBUILD KIT W/ ROD	WIL 260-1336

# GAS PEDALS

## ORIGINAL TUBULAR STEEL PEDALS

- ★AVAILABLE TO MOUNT TO THE FRONT FIREWALL OR THE SIDE FIREWALL (WITH EITHER A STRAIGHT OR A 15° ANGLED MOUNT)
- ★LIGHTWEIGHT STEEL CONSTRUCTION
- ★GIVES QUALITY, SMOOTH RESPONSE
- ★EASY TO INSTALL

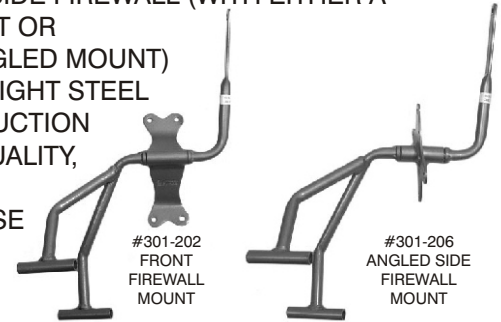

DESCRIPTION	PART #
FRONT FIREWALL MOUNT	301-202
STRAIGHT SIDE FIREWALL MOUNT	301-204
ANGLED SIDE FIREWALL MOUNT	301-206

## ALUMINUM, NEEDLE BEARING PEDALS

- ★FRONT FIREWALL MOUNT AND STRAIGHT & 15° ANGLED SIDE FIREWALL MOUNTS AVAILABLE
- ★SPLINED PIVOT SHAFT SUPPORTED BY DUAL NEEDLE BEARINGS & A KNURLED ALUMINUM ROLLER FOOT PEDAL ENSURE THAT YOU WILL HAVE THE SMOOTHEST OPERATING PEDAL IN THE INDUSTRY
- ★BOTH THE PEDAL & THE THROTTLE ARM CAN BE INDEXED TO SUIT YOUR SPECIFIC APPLICATION

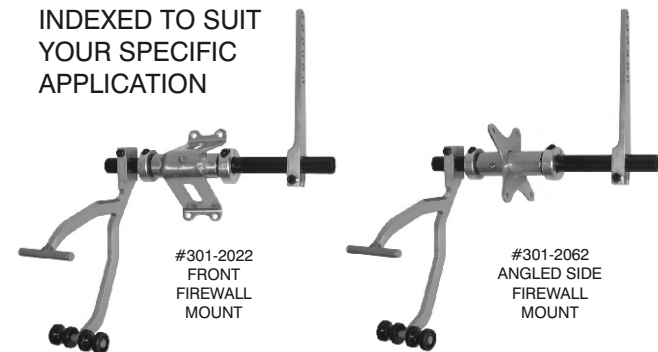

DESCRIPTION	PART #
FRONT FIREWALL MOUNT, BEARING	301-2022
STRAIGHT SIDE FIREWALL MT, BEARING	301-2042
ANGLED SIDE FIREWALL MT, BEARING	301-2062

Place your order at (479) 646-6988, Fax to (479) 646-5939, or visit [www.southwestspeed.com](http://www.southwestspeed.com)



# BRAKE FITTINGS



	DESCRIPTION	COMMON APPLICATION	PART #
1.	1/8" NPT FEMALE TO -4 AN MALE	GAUGE FITTING	301-001
2.	1/8" NPT MALE TO -3 AN MALE	WILWOOD ALUMINUM CALIPERS, EXCEPT GM	301-002
	1/8" NPT MALE TO -4 AN MALE	WILWOOD ALUMINUM CALIPERS, EXCEPT GM	301-003
	3/16" INF MALE TO -4 AN MALE	ADAPTS 3/16" INVERTED FLARE FEMALE TO -4 AN MALE	301-016
3.	1/8" NPT TO -4 AN, 90°	WILWOOD ALUMINUM CALIPERS, EXCEPT GM	301-013
4.	1/8" NPT TO -4 AN, TALL, 90°	WILWOOD GM ALUMINUM CALIPERS	301-014
5.	7/16"- 20 O-RING TO -4 AN, 90°	BIG GM CALIPERS	301-020
6.	3/16" STEEL LINE TO -4 AN	CHASSIS MOUNT	301-025
7.	10MM -1.50 TO -4 AN, W/ WASHER	SMALL GM METRIC CALIPERS	301-050
8.	10MM -1.50, BANJO BOLT, W/ WASHERS	SMALL GM METRIC CALIPERS	301-055
9.	10MM LONG BANJO TO -4 AN	SMALL GM METRIC CALIPERS	301-060
10.	10MM-1.5 MALE TO 1/8" NPT FEMALE	SMALL GM METRIC CALIPERS	301-062
11.	1/8" BRASS PIPE FEMALE UNION	CONNECTS 1/8" NPT LINES OR FITTINGS	301-069
12.	1/8" NPT TO 3/16" STEEL LINE	MASTER CYLINDER FITTING	301-070
13.	1/8" NPT TO 3/16" STEEL LINE, 90°	MASTER CYLINDER FITTING	301-072
14.	1/8" NPT BLEEDER VALVE	ALL ALUMINUM CALIPERS	301-080
15.	3/8"-24 MALE TO 3/16" LINE FEMALE	GIRLING MASTER CYLINDER	301-088
16.	3/16" STEEL LINE COUPLER	2 - 3/16" INVERTED FLARE FEMALE	290-099
17.	1/8" NPT FEM. COUPLER TO 3/16" LINE	1 - 3/16" INVERTED FLARE FEMALE, 1 - 1/8" NPT FEM.	301-004
	3/16" STEEL LINE TEE FITTING	3 - 3/16" INVERTED FLARE FEMALE	301-090
	1/8" NPT FEMALE TEE TO 3/16" LINE	2 - 3/16" INVERTED FLARE FEMALE, 1 - 1/8" NPT FEM.	301-091
19.	1/8" NPT FEMALE TEE FITTING	3 - 1/8" NPT THREAD FEMALE	301-092
	3/16" RUN TEE FITTING	1 - 3/16" INVERTED FLARE MALE, 2 - 3/16" LINE FEMALE	301-093
	1/8" NPT RUN TEE FITTING	1 - 1/8" NPT MALE & FEMALE, 1 - 3/16" LINE FEMALE	301-094
20.	BRAKE FITTING CLIP (PACKAGE OF 4)	CHASSIS MOUNT (USED WITH #301-025)	301-100

## BRAKE DUCT HOSE

- ★3" ID", BLACK IN COLOR
- ★VERY FLEXIBLE
- ★SAFE UP TO 300°
- ★SOLD IN 10' LENGTHS



PART #210-003

## BRAKE DUCT BLOWER MOTOR

- ★ACCEPTS 3" BRAKE DUCT
- ★12 VOLT
- ★3.1 AMPS
- ★145 CFM



PART #210-044

Place your order at (479) 646-6988, Fax to (479) 646-5939, or visit [www.southwestspeed.com](http://www.southwestspeed.com)

# BUMPER MOUNTED BRAKE DUCTS

- ★ FITS 3" BRAKE HOSE
- ★ HIGH QUALITY PLASTIC
- ★ EASY INSTALLATION

**PART #210-005**



# OFFSET SINGLE HOLE

- ★ FITS 3" BRAKE HOSE
- ★ HIGH QUALITY PLASTIC
- ★ EASY INSTALLATION

**PART #210-007**



# TILTED HOLE

- ★ STEPPED DESIGN ENABLES DUCT TO FIT 3" OR 4" BRAKE HOSE
- ★ SINGLE CENTERED INLET, TILTED TO ANGLE AWAY FROM THE GROUND
- ★ HIGH QUALITY PLASTIC
- ★ EASY INSTALLATION



**PART #210-050**

# DUAL HOLE

- ★ FITS 3" BRAKE HOSE
- ★ HIGH QUALITY PLASTIC
- ★ EASY INSTALLATION

**PART #210-011**



# WINDOW MOUNTED DUCTS

- ★ FITS 3" BRAKE HOSE
- ★ HIGH QUALITY CLEAR PLASTIC
- ★ EASY INSTALLATION

**PART #210-019**



# DUAL HOLE

- ★ FITS 3" BRAKE HOSE
- ★ HIGH QUALITY CLEAR PLASTIC
- ★ EASY INSTALLATION

**PART #210-023**



# MOTOR PLATES

- ★ 6061-T6 1/4" ALUMINUM CNC MACHINED PLATE
- ★ INSTALLS BETWEEN ENGINE AND BELLHOUSING

DRIVER SIDE

PASSENGER SIDE

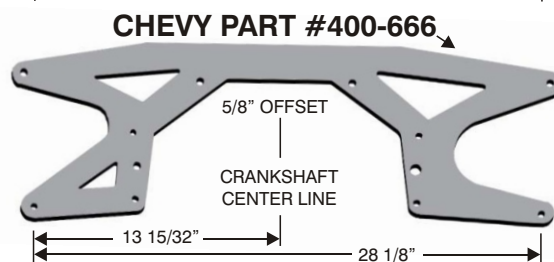
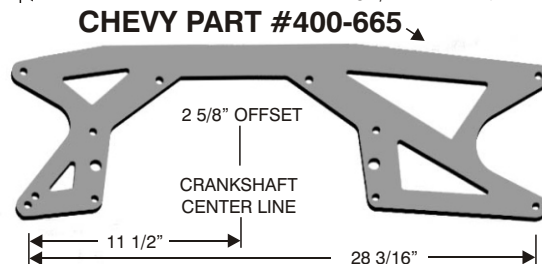
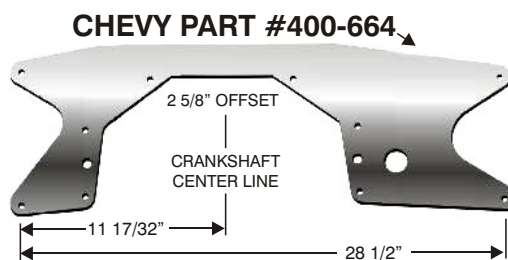
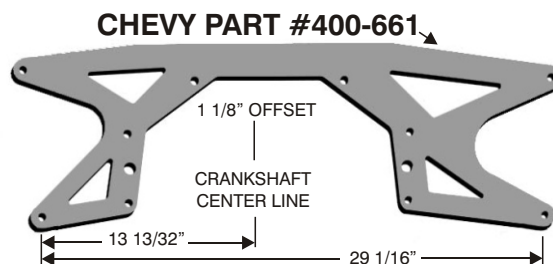
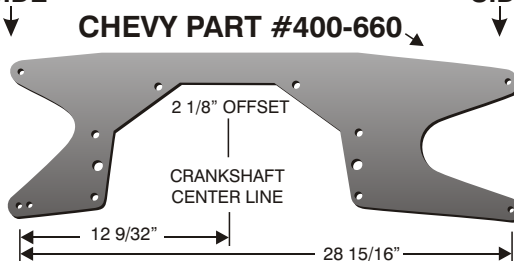

\* SOME CHASSIS BUILDERS INSTALL THE #400-666 MOTOR PLATE BACKWARDS

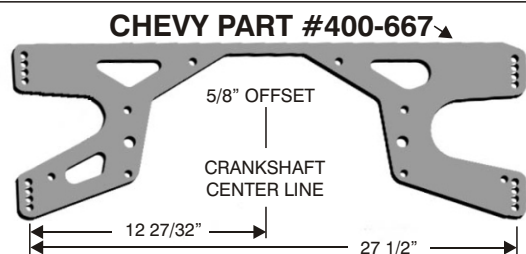

# MOTOR PLATES

- ★6061-T6 1/4" ALUMINUM CNC MACHINED PLATE
  - ★INSTALLS BETWEEN ENGINE AND BELLHOUSING
- DRIVER SIDE PASSENGER SIDE

↓ FORD OR CHEVY PART #400-670 ↓

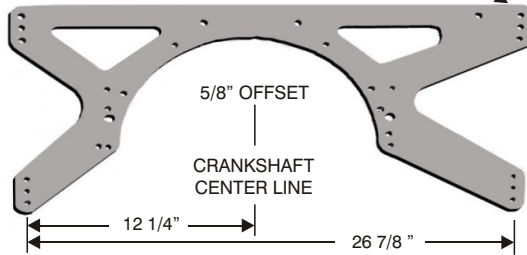

**351 FORD PART #400-675**

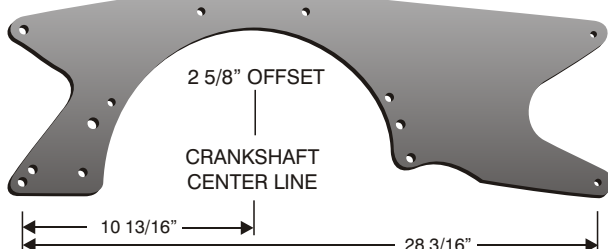

**351 FORD PART #400-676**

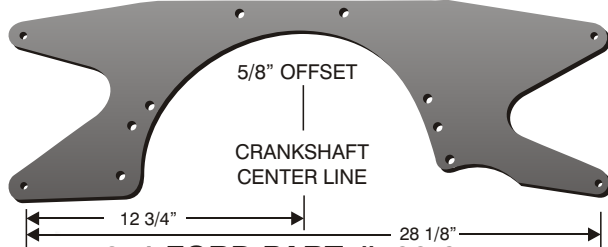

**351 FORD PART #400-677**

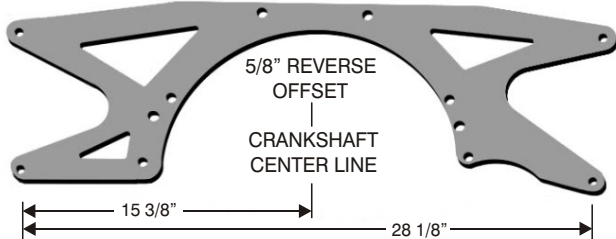

**351 FORD PART #400-678**

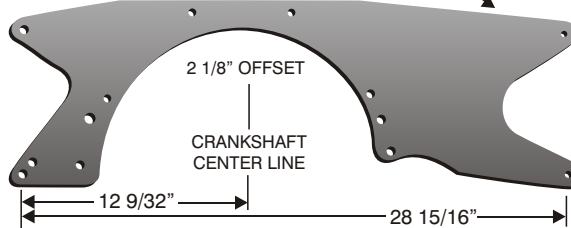

**MOPAR PART #400-686**

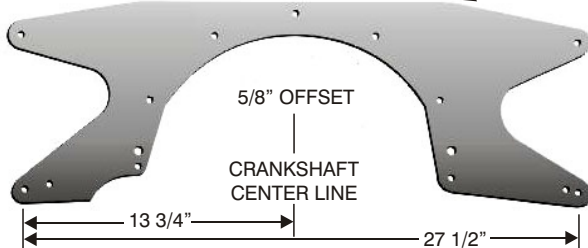

# MOTOR PLATE TABS

- ★1" & 1 1/2" CHANNELS
- ★PRE-DRILLED WITH 3/8" BOLT HOLES
- ★PRICED EACH & SOLD IN BAGS OF 10

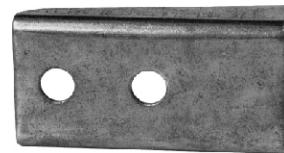

DESCRIPTION	PART #
WELD TAB, 1" CHANNEL, 2 1/2" LONG	701-055
WELD TAB, 1 1/2" CHANNEL, 2" LONG	701-065
WELD TAB, 1 1/2" CHANNEL, 3" LONG	701-067
WELD TAB, 1 1/2" CHANNEL, 4 3/4" LONG	701-068

# CHEVY MOTOR MOUNTS SOLID FRONT MOUNTS

- ★SOLID STEEL MOTOR MOUNTS REPLACE STOCK, OEM-STYLE RUBBER MOUNTS TO ELIMINATE TORQUE LOSS & BINDING LINKAGES, A COMMON RESULT OF EXCESSIVE ENGINE MOVEMENT
- ★THESE SOLID MOUNTS ELIMINATE THE NEED FOR BULKY TORQUE STRAPS OR CHAINS
- ★#400-7003 & #400-7008 ARE DESIGNED TO BE USED TOGETHER; EACH IS SOLD 2 PER PACK
- ★FIT 74-81 CAMARO & FIREBIRD, 73-88 CHEVELLE, MALIBU, MONTE CARLO, & EL CAMINO, 73-79 NOVA, & 76-90 IMPALA & CAPRICE

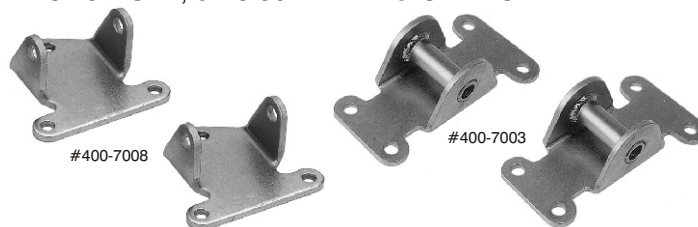

DESCRIPTION	PART #
SOLID CHEVY FRONT MOTOR MOUNTS	400-7008
SOLID MOTOR MOUNT FRAME PLATES	400-7003

# CHEVY TRANSMISSION MOUNT

- ★REPLACES STOCK, OEM-STYLE, SOFT RUBBER MOUNT TO ELIMINATE LINKAGE BINDING, DRIVELINE MISALIGNMENT, & UNWANTED TRANSMISSION MOVEMENT IN RACING & STREET PERFORMANCE
- ★STURDY, SOLID MOUNT IS CONSTRUCTED FROM 3/16" STEEL & FEATURES SLOTTED HOLES ON TOP FOR TRANSMISSION MOUNTING & THREADED NUTS WELDED TO THE BOTTOM FOR CROSSMEMBER MOUNTING
- ★FOR USE ON 58-88 CHEVY, EXCEPT 82-92 CAMARO
- ★FITS POWERGLIDE, TH-350, TH-400, & ALL BORG-WARNER, MUNCIE, SAGINAW, CHRYSLER 4-SPEED, & DOUG NASH 5-SPEED TRANSMISSIONS
- ★MUST BE USED WITH SOLID MOTOR MOUNTS TO PREVENT BREAKAGE OF TRANSMISSION CASE & ENGINE BLOCK DUE TO TORSIONAL STRESS

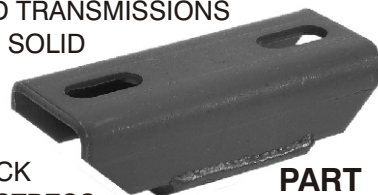

**PART #400-7015**

Place your order at (479) 646-6988, Fax to (479) 646-5939, or visit [www.southwestspeed.com](http://www.southwestspeed.com)



# CHEVY MOTOR MOUNTS

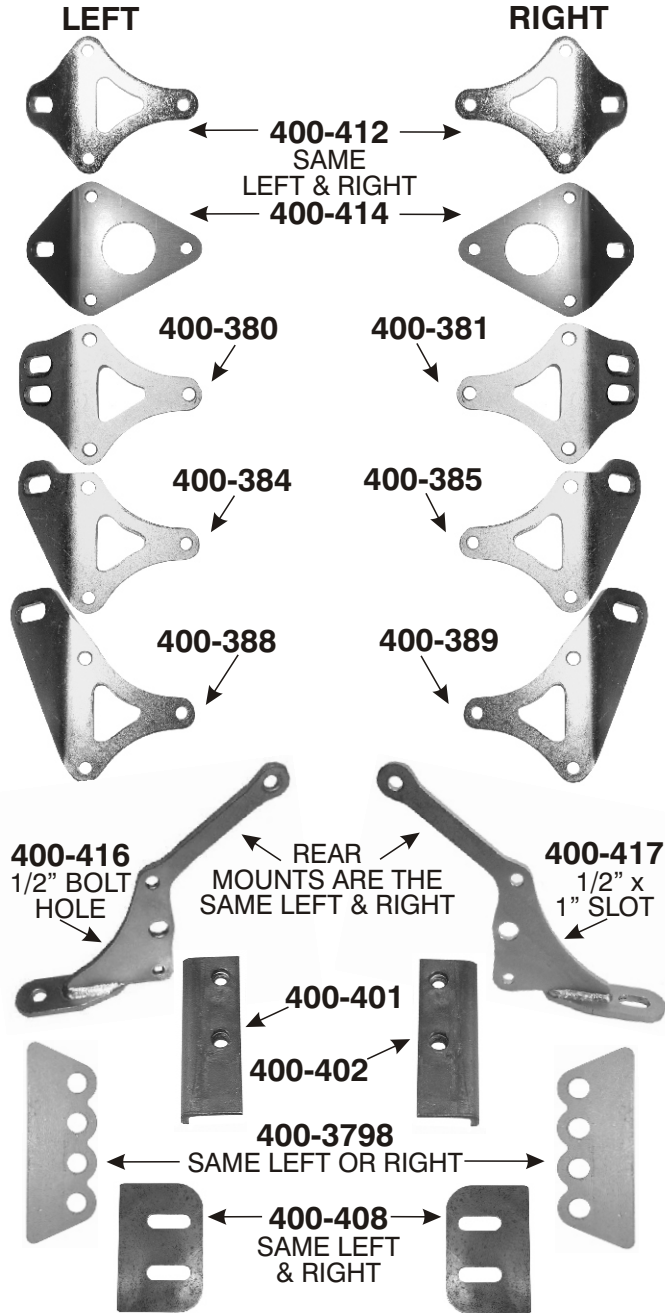

DESCRIPTION	PART #
FRONT STEEL MOUNT	400-412
FRONT ALUMINUM MOUNT	400-414
FRONT STEEL, 1" SETBACK, LEFT	400-380
FRONT STEEL, 1" SETBACK, RIGHT	400-381
FRONT STEEL, 2" SETBACK, LEFT	400-384
FRONT STEEL, 2" SETBACK, RIGHT	400-385
FRONT STEEL, 3 3/8" SETBACK, LEFT	400-388
FRONT STEEL, 3 3/8" SETBACK, RIGHT	400-389
REAR STEEL MOUNT, 1/2" HOLE	400-416
REAR STEEL MOUNT, 1" LONG SLOT	400-417
FRONT WELD PLATE, 2 POSITION, LEFT	400-401
FRONT WELD PLATE, 2 POSITION, RIGHT	400-402
FRONT WELD PLATE, 4 POSITION	400-3798
REAR WELD PLATE	400-408

# MOTOR MOUNT BOLT KIT

- ★ FITS SMALL BLOCK CHEVY FRONT MOTOR MOUNTS ONLY
- ★ HAVING THIS KIT WILL SAVE YOU TIME WHEN YOU NEED IT MOST
- ★ 3/8" COARSE THREADS
- ★ SOLD IN PACKS OF 6



**PART #440-200**

# FORD MOTOR MOUNTS

- ★ LIGHTWEIGHT STEEL MOUNTS FOR SMALL BLOCK FORDS

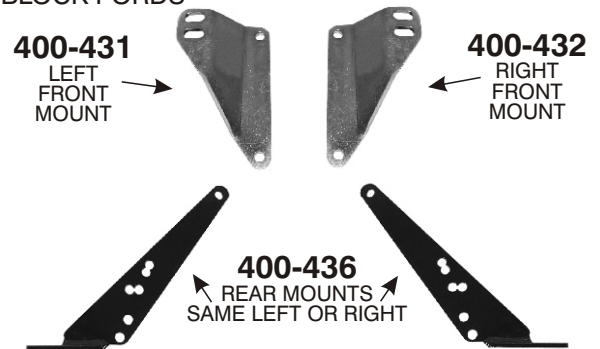

NOTE: ALL MOTOR MOUNTS AND PLATES ARE SOLD EACH. LEFT REFERS TO THE DRIVERS SIDE.

# ENGINE CRADLE



- ★ HEAVY DUTY STEEL CONSTRUCTION
- ★ 1000LB CAPACITY
- ★ 3" SWIVEL CASTERS
- ★ POWDER COATED FINISH
- ★ ENGINE BOLTS INCLUDED

**PART #410-805**

# ENGINE ASSEMBLY STAND

- ★ ASSEMBLY STAND
- ★ 1000LB CAPACITY
- ★ ADAPTS TO ALL ENGINE BLOCKS

**PART #705-1001**



# ENGINE BAG



- ★ HEAVY DUTY WATER RESISTANT VINYL
- ★ WILL FIT OVER ANY MOTOR
- ★ PERFECT FOR KEEPING DIRT, DEBRIS, AND MOISTURE OUT OF YOUR ENGINE

**PART #OWC EB-1000**

Place your order at (479) 646-6988, Fax to (479) 646-5939, or visit [www.southwestspeed.com](http://www.southwestspeed.com)

# DRY SUMP OIL PUMPS

- ★1, 2, 3, & 4 STAGE EXTERNAL PUMPS
- ★FITTINGS INCLUDED
- ★5/8" KEYED DRIVESHAFT
- ★ADJUSTABLE PRESSURE
- ★EASY MOUNTING
- ★AVAILABLE WITH A MOUNTING BRACKET TO BOLT TO A BERT, BRINN, OR FALCON BELLHOUSING

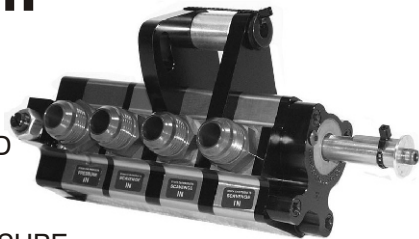

GEAR	1 STAGE	2 STAGE	3 STAGE	4 STAGE
1.20" WIDE	412-100	412-110	412-120	412-130
1.45" WIDE	412-102	412-112	412-122	412-132
1.70" WIDE	412-104	412-114	412-124	412-134
1.20" WIDE WITH B., B. & F. MOUNT			412-121	412-131
1.45" WIDE WITH B., B. & F. MOUNT	412-103		412-123	412-135

# OIL PUMPS WITH POWER STEERING & FUEL PUMP

- ★1, 3, & 4 STAGE EXTERNAL PUMPS WITH EITHER KSE TANDEM X POWER STEERING & FUEL PUMPS, OR WITH KSE PS PUMP & WATERMAN LM300 FUEL PUMP
- ★FITTINGS INCLUDED
- ★ADJUSTABLE PRESSURE
- ★5/8" KEYED DRIVESHAFT
- ★INCLUDES THE MOUNTING BRACKET TO CONNECT THE PUMPS, AND IT BOLTS DIRECTLY TO A BERT, BRINN, OR FALCON BELLHOUSING

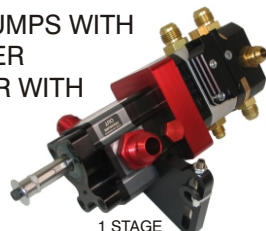

1 STAGE WITH KSE TANDEM X PS & FUEL PUMPS #412-107 SHOWN

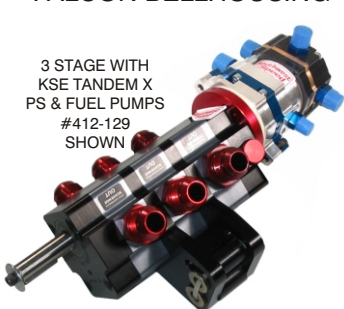

3 STAGE WITH KSE TANDEM X PS & FUEL PUMPS #412-129 SHOWN

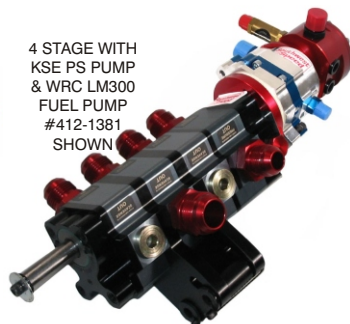

4 STAGE WITH KSE PS PUMP & WRC LM300 FUEL PUMP #412-1381 SHOWN

DESCRIPTION	W/KSE TANDEM X	W/KSE PS & WRC LM300
1 STAGE	412-107	412-1071
3 STAGE	412-129	412-1291
4 STAGE	412-138	412-1381

# DRY SUMP PUMP PARTS HEX DRIVE SCREW



- ★3/8" -24 THREADS
- ★DRIVES TANDEM PUMPS OFF THE BACK OF DRY SUMP PUMP

PART #412-158

# DRY SUMP PUMP PARTS END BODIES

- ★BODIES COME COMPLETE WITH BEARINGS & SEALS

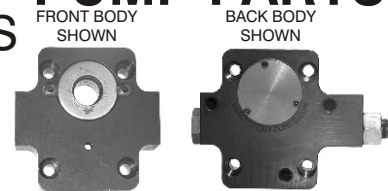

DESCRIPTION	PART #
DRY SUMP PUMP BACK BODY COMPLETE	412-211
DRY SUMP PUMP FRONT BODY COMPLETE	412-220

# GEAR BODIES

- ★LIGHTWEIGHT ALUMINUM DESIGN
- ★-12 AN PORTS ON ALL EXCEPT #412-2028
- ★STRAIGHT & 45° PORT OUTLETS AVAILABLE
- ★1.20" & 1.45" BODY WIDTHS



DESCRIPTION	PART #
GEAR BODY, 1.20"	412-201
GEAR BODY, 1.20", 45° PORT	412-202
GEAR BODY, 1.45" (-10 AN PORT)	412-2028
GEAR BODY, 1.45"	412-203
GEAR BODY, 1.45", 45° PORT	412-204
SEPARATOR PLATE, .475" THICK	412-219
PORTED SEPARATOR PLATE, .475" TK.	412-218

# IDLER & DRIVE GEARS

- ★SOLD INDIVIDUALLY TO REPLACE GEAR AS NEEDED
- ★MADE FROM HIGH QUALITY STEEL OR BRONZE
- ★1.20" OR 1.45" GEAR WIDTHS TO CHOOSE FROM

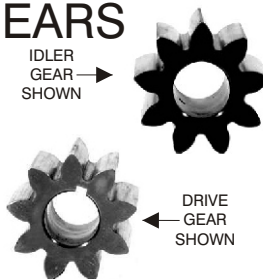

DESCRIPTION	PART #
IDLER GEAR, 1.20"	412-190
IDLER GEAR, 1.45"	412-192
IDLER GEAR, 1.45", BRONZE	412-194
DRIVE GEAR, 1.20"	412-191
DRIVE GEAR, 1.45"	412-193

# DRIVE & IDLER SHAFTS

- ★3 OR 4 STAGE
- ★POLISHED & HARDENED STEEL FOR LONG LIFE



DESCRIPTION	PART #
IDLER SHAFT, 3 STAGE	412-171
IDLER SHAFT, 4 STAGE	412-173
DRIVESHAFT, 3 STAGE	412-154
DRIVESHAFT, 3 STAGE W/TANDEM PUMP	412-155
DRIVESHAFT, 4 STAGE	412-156
DRIVESHAFT, 4 STAGE W/TANDEM PUMP	412-157

Place your order at (479) 646-6988, Fax to (479) 646-5939, or visit [www.southwestspeed.com](http://www.southwestspeed.com)

# DRY SUMP PUMP PARTS

## PUMP FITTINGS

- ★LIGHTWEIGHT ALUMINUM
- ★NO LEAK O-RING DESIGN
- ★ADAPTS YOUR CHOICE OF LINES TO ANY GEAR BODY



DESCRIPTION	PART #
PUMP PLUG ONLY, -10 AN O-RING	412-291
PUMP PLUG ONLY, -12 AN O-RING	412-2912
PUMP FITTING, -10 AN O-RING TO -10 AN	412-292
PUMP FITTING, -10 AN O-RING TO -12 AN	412-293
PUMP FITTING, -12 AN O-RING TO -12 AN	412-294
PUMP FITTING, -12 AN O-RING TO -16 AN	412-295
PUMP FITTING, -12 AN O-RING TO -10 AN	412-296
PUMP FITTING, -10 AN O-RING TO -16 AN	412-297

## FILTER FITTING SCREEN KIT

- ★INSTALL IN FITTINGS TO TRAP METAL CHIPS AND DEBRIS
- ★INCLUDES EPOXY CEMENT AND 4 SCREENS PER KIT
- ★MACHINING REQUIRED FOR INSTALLATION



**PART #MOR 23965**

## VALVE BODY PLUG



- ★5/8"-18 STRAIGHT THREAD O-RING PLUG
- ★PLUGS THE POPPET RELIEF VALVE HOLE

**PART #412-290**

## ADJUSTER NUT & SCREW

- ★ADJUSTS OIL PRESSURE UP OR DOWN AS NEEDED
- ★COMES WITH STUD, NUT, & O-RING

**PART #412-224**



NOTE: FOR A CONSTANT STREAM OF NEW PRODUCTS & UP-TO-THE-SECOND PRICING, VISIT [WWW.SOUTHWESTSPEED.COM](http://WWW.SOUTHWESTSPEED.COM)

# DRY SUMP PUMP PARTS

## PRESSURE SPRINGS

- ★SPRINGS ALLOW YOU TO CHANGE YOUR OIL PRESSURE
- ★SOLD EACH
- ★MADE FROM HIGH QUALITY SPRING STEEL
- ★2 RATES TO CHOOSE FROM



DESCRIPTION	PART #
HIGH PRESSURE SPRING	412-282
MEDIUM PRESSURE SPRING	412-283

## POPPET RELIEF VALVE



- ★PRECISION GROUND FOR PRECISE MOVEMENT

**PART #412-225**

## SEAL KIT

- ★INCLUDES THE SEAL & ALL THE O-RINGS NEEDED FOR A PUMP REBUILD



DESCRIPTION	PART #
SEAL KIT	412-280
DRY SUMP REAR SEAL, FOR TANDEM PUMP	412-278

## MOUNTING PLATES & ADAPTERS

- ★MOUNT PLATES AVAILABLE:
  - \*FRONT PUMP MOUNT
  - \*BACK PUMP MOUNT
  - \*BERT/BRINN MOUNT (FRONT OR BACK)
  - \*ADJUSTABLE BERT/BRINN MOUNT
- ★ADAPTERS FOR KSE TANDEM PUMPS & WATERMAN FUEL PUMPS ARE AVAILABLE
- ★FITS SOUTHWEST SPEED, STOCK CAR PRODUCTS, & WEAVER PUMPS



#412-217



#412-228



#412-2281



#412-213

DESCRIPTION	PART #
MOUNT PLATE, FRONT	412-215
MOUNT PLATE, BACK	412-217
MOUNT PLATE, BERT/BRINN, FRONT OR BACK	412-228
ADJUSTABLE MOUNT PLATE, BERT/BRINN	412-2281
ADAPTER FOR KSE TANDEM PUMP	412-213
ADAPTER FOR WATERMAN FUEL PUMP	412-214
1.2" MOUNTING PLATE SPACER	412-230

Place your order at (479) 646-6988, Fax to (479) 646-5939, or visit [www.southwestspeed.com](http://www.southwestspeed.com)



# DRY SUMP PUMP PARTS

## PUMP RELOCATION BRACKETS

- ★RELOCATION BRACKETS MOVE DRY SUMP PUMPS UP & TO THE LEFT
- ★FIT SOUTHWEST SPEED, STOCK CAR PRODUCTS, & WEAVER PUMPS
- ★LIGHTWEIGHT ALUMINUM CONSTRUCTION
- ★#412-298 MOVES THE PUMP UP 1/2" & TO THE LEFT 7/8"
- ★#412-227 HAS ONE POSITION THAT MOVES IT UP 1" & TO THE LEFT 1/2" AND ANOTHER POSITION THAT MOVES IT UP 2" & TO THE LEFT 1"



DESCRIPTION	PART #
SBC RELOCATION BRKT, SINGLE POS.	412-298
SBC RELOCATION BRKT, DUAL POSITION	412-227

## STUDS

- ★HOLD THE END CAPS & BODIES TOGETHER

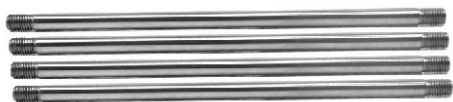

- ★PRICED EACH & SOLD IN PACKS OF 4

DESCRIPTION	PART #
STUD FOR 3 STAGE, 6.150" LONG	412-263
STUD FOR 4 STAGE, 7.825" LONG	412-265
GEAR BODY ALLEN NUTS (SOLD EACH)	412-260

# DRIVE KITS

- ★#412-504 & #412-529 DRIVE THE PUMP OFF THE CRANK & INCLUDE CRANK PULLEY, OIL PUMP PULLEY, BELT, CRANK BOLT, END CAP, BELT GUIDE, MANDREL, & ALL SPACERS REQUIRED
- ★#412-535 DRIVES THE PUMP OFF THE WATER PUMP & INCLUDES DRIVE PULLEY, OIL PUMP PULLEY, BELT, FAN SPACER, BRACKET TO MOUNT TANDEM PUMP TO WATER PUMP, & ALL NECESSARY HARDWARE



DESCRIPTION	PART #
GILMER DRIVE KIT: 16T CRANK, 28T PUMP, & 22 1/2" BELT	412-504
HTD DRIVE KIT: 22T CRANK, 40T PUMP, & 800MM BELT	412-529
HTD DRIVE KIT: 28T WATER PUMP, 37T PUMP, & 720MM BELT	412-535

NOTE: DRIVE KITS CAN BE ALTERED IN ANYWAY WITH THE DRIVE KIT PARTS LISTED ON THE RIGHT SIDE OF THIS PAGE & ON THE NEXT PAGE.

# DRIVE KIT PARTS

## DRIVE MANDRELS

- ★1" O.D. X 3 1/2" LONG ALUMINUM MANDREL
- ★COMES WITH HARMONIC BALANCER KEY & PULLEY KEY
- ★FITS SECURELY IN BALANCER



PART #412-300

## MANDREL BOLT

- ★7/16"-20 x 5 1/2" BOLT
- ★CONNECTS DRIVE ASSY. TO CRANKSHAFT



PART #412-322

## DRIVE MANDREL END CAP

- ★7075 T-6 ALUMINUM
- ★FITS OVER MANDREL END
- ★ALSO WORKS AS BELT GUIDE



PART #412-321

## DRIVE MANDREL SPACERS



- ★LIGHTWEIGHT ALUMINUM
- ★FITS 1" KEYED MANDREL
- ★HELPS ALIGN BELT
- ★STACKABLE FOR PERFECT LENGTH

DESCRIPTION	PART #
1/4" WIDE DRIVE SPACER	412-302
3/8" WIDE DRIVE SPACER	412-303
1/2" WIDE DRIVE SPACER	412-304
5/8" WIDE DRIVE SPACER	412-305
3/4" WIDE DRIVE SPACER	412-306
7/8" WIDE DRIVE SPACER	412-307
1" WIDE DRIVE SPACER	412-308
1 1/8" WIDE DRIVE SPACER	412-309
1 1/4" WIDE DRIVE SPACER	412-310

## BELT GUIDES

- ★.090" ALUMINUM
- ★FITS 1" MANDREL OR SNAPS IN PULLEY
- ★HELPS KEEP BELT ON
- ★SOLD IN PAIRS



#412-311



#412-464

DESCRIPTION	PART #
BELT GUIDE KIT, FITS 1" MANDREL (2)	412-311
BELT GUIDE KIT, SNAP-IN, 28 T PULLEY (2)	412-338
BELT GUIDE KIT, SNAP-IN, 40 T PULLEY (2)	412-464

Place your order at (479) 646-6988, Fax to (479) 646-5939, or visit [www.southwestspeed.com](http://www.southwestspeed.com)

# DRIVE KIT PARTS PULLEYS

- ★GILMER OR HTD TEETH
- ★HARD ANODIZED
- ★7075 T-6 ALUMINUM
- ★CNC MACHINED
- ★EXTRA WIDE



DESCRIPTION	PART #
16T GILMER CRANK PULLEY, 1" WIDE, 1" ID	412-316
17T GILMER CRANK PULLEY, 1" WIDE, 1" ID	412-317
28T GILMER PUMP PULLEY, 1" WIDE, 5/8" ID	412-328
22T HTD CRANK PULLEY, 1 1/4" WIDE, 1" ID	412-432
40T HTD PUMP PULLEY, 1 1/4" WIDE, 5/8" ID	412-454
40T HTD PUMP PULLEY, 1 1/4" W/GUIDES, 5/8" ID	412-456
DRY SUMP GEAR DRIVE KEY, 3/16" GROUND	412-258

## CHECK YOUR PULLEY BEFORE YOU BUY YOUR BELT

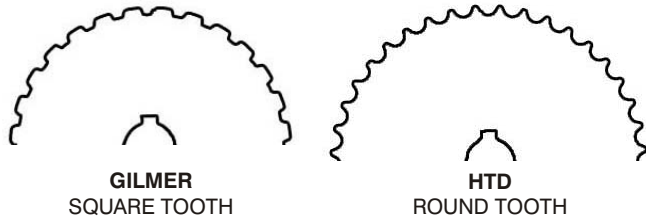

## COGGED BELTS

- ★NON-SLIP COG BELT
- ★HIGH PERFORMANCE
- ★HTD OR GILMER TEETH



DESCRIPTION	PART #
GILMER BELT, 3/8" x 29" LONG, FUEL PUMP	412-368
GILMER BELT, 1/2" x 32 1/4" L., FUEL PUMP	412-372
GILMER BELT, 1/2" x 34 1/2" L., FUEL PUMP	412-374
GILMER BELT, 1" x 22 1/2" LONG	412-392
GILMER BELT, 1" x 24" LONG	412-394
GILMER BELT, 1" x 25 1/2" LONG	412-395
GILMER BELT, 1" x 27" LONG	412-397
HTD BELT, 8 x 20MM x 560MM LONG	412-401
HTD BELT, 8 x 20MM x 600MM LONG	412-402
HTD BELT, 8 x 20MM x 640MM LONG	412-403
HTD BELT, 8 x 20MM x 720MM LONG	412-404
HTD BELT, 8 x 20MM x 800MM LONG	412-405
HTD BELT, 8 x 30MM x 600MM LONG	412-410
HTD BELT, 8 x 30MM x 640MM LONG	412-412
HTD BELT, 8 x 30MM x 800MM LONG	412-416

## 1 QUART FILLER TANKS

- ★PROVIDES REMOTE FILLING CAPABILITIES
- ★3/4" NPT THREADS AT THE BOTTOM & 3/8" NPT THREADS AT THE TOP
- ★USED WITH OIL OR WATER
- ★8" LENGTH X 3 1/8" DIAMETER; 1 QT. CAPACITY



DESCRIPTION	PART #
FILLER TANK, FIREWALL MOUNT	MOR 85450
FILLER TANK, ROLL CAGE MOUNT	MOR 85460

# DRY SUMP TANKS 3 GALLON TANK, ROUND



- ★12 QT. SYSTEM
- ★16 1/2" TALL x 9" O.D.
- ★2 PIECE ALUMINUM DESIGN W/ INTERNAL BAFFLE
- ★KIT INCLUDES BRACKETS & -12 AN FITTINGS WITH O-RINGS

DESCRIPTION	PART #
TANK KIT COMPLETE W/ FITTINGS, 12 QT.	411-530
TANK ONLY, 12 QT. DRY SUMP	411-535
MOUNTING BRACKETS (SOLD AS A PAIR)	411-540
-12 AN FITTING KIT ONLY	411-542
REPLACEMENT O-RING ONLY	411-550

## 4 GALLON ASPHALT TANK

- ★ASPHALT DRY SUMP TANK & FILTER WITH REMOTE FILLER
- ★INCLUDES FILLER & HOSE
- ★LIGHTWEIGHT ALUMINUM WITH INTERNAL BAFFLE
- ★16 QT. SYSTEM
- ★CONVENIENT SIGHT GAUGE
- ★-16 AN OUTLET, -12 AN INLET, -12 AN VENT, & -10 AN DRAIN
- ★1/2" NPT FEMALE SERVICE PORT



DESCRIPTION	PART #
TANK & FILTER W/ REMOTE FILLER, -16 AN	411-502
REMOTE FILLER ONLY WITH HOSE	411-517
ALUM. ADAPTER, -16 AN FEM. TO -12 AN MALE	901-094

## 4 GALLON DIRT TANKS

- ★DIRT DRY SUMP TANK & FILTER
- ★LIGHTWEIGHT ALUMINUM WITH INTERNAL BAFFLE
- ★FILLS FROM TOP CAP
- ★16 QT. SYSTEM
- ★CONVENIENT SIGHT GAUGE
- ★BUILT-ON OIL FILTER
- ★-16 AN OUTLET, -12 AN INLET, -8 AND/OR -16 AN VENTS, & -8 AN DRAIN



DESCRIPTION	PART #
TANK & FILTER KIT, -16 AN, R	411-504
TANK & FILTER KIT, -16 AN, G	411-512
ALUM. ADAPTER, -16 AN FEM. TO -12 AN MALE	901-094

Place your order at (479) 646-6988, Fax to (479) 646-5939, or visit [www.southwestspeed.com](http://www.southwestspeed.com)

# SMALL BLOCK CHEVY OIL PANS

7 QUART, 7" DEEP OVAL TRACK PAN WITH LOUVERED TRAY

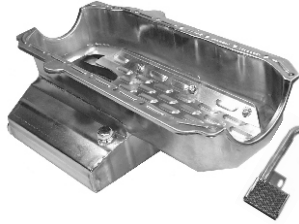

- ★7 QUART, 7" DEEP SUMP
- ★FEATURES 3 TRAP DOORS, A CRANK SCRAPER, & A REMOVABLE LOUVERED TRAY
- ★USES SBC & BBC\*\* PUMPS

DESCRIPTION	PART #
7 QUART, 7" W/ LOUVERED TRAY	413-059
PICKUP FOR SBC PUMP, 7"	413-036
PICKUP FOR BBC PUMP, 7"***	413-038

7 QT., 7 1/2" DEEP OVAL TRACK

- ★7 QUART, 7 1/2" DEEP
- ★2 TRAP DOORS
- ★AVAILABLE FOR PRE-1986 AND 86 & UP MOTORS
- ★USES SBC & BBC\*\* PUMPS



DESCRIPTION	PART #
7 QUART, 7 1/2", LEFT HAND DIPSTICK	413-066
7 QUART, 7 1/2", RIGHT HAND DIPSTICK	413-0662
7 QUART, 7 1/2", 1986 & UP, RH DIPSTICK	413-0663
PICKUP FOR SBC PUMP, 7 1/2"	413-029
PICKUP FOR BBC PUMP, 7 1/2"***	413-032

8 QUART, 7" DEEP OVAL TRACK



- ★8 QUART, 7" DEEP
- ★5 TRAP DOORS
- ★AVAILABLE FOR PRE-1986 AND 86 & UP MOTORS
- ★USES SBC & BBC\*\* PUMPS

DESCRIPTION	PART #
8 QUART, 7", LEFT HAND DIPSTICK	413-067
8 QUART, 7", 1986 & UP, RH DIPSTICK	413-0673
PICKUP FOR SBC PUMP, 7"	413-036
PICKUP FOR BBC PUMP, 7"***	413-038

5 QT., 7 1/2" DEEP "STOCK-TYPE"

- ★5 QUART, 7 1/2" DEEP
- ★USE WHERE "CLAIMER-TYPE" OIL PANS ARE REQUIRED
- ★2 TRAP DOORS



DESCRIPTION	PART #
7 1/2" DEEP, STOCK APPEARING PAN	413-040
PICKUP FOR SBC PUMP, 7 1/2"	413-030
PICKUP FOR BBC PUMP, 7 1/2"***	413-032

\*\*WHEN USING A BBC PUMP & BBC PICKUP WITH THESE PANS, SOME MINOR TRIMMING MAY BE REQUIRED

# SMALL BLOCK CHEVY OIL PANS

DRY SUMP

- ★4 1/4" DEEP
- ★-12 AN FITTINGS COMING OUT OF EITHER THE LEFT (DRIVERS) SIDE OR THE RIGHT (PASSENGERS) SIDE



DESCRIPTION	PART #
4 1/4" DEEP PAN, LEFT-SIDE FITTINGS	413-148
4 1/4" DEEP PAN, RIGHT-SIDE FITTINGS	413-150

# SMALL BLOCK FORD OIL PANS

OVAL TRACK

PART #413-220

- ★351W, 7 1/2" DEEP REAR SUMP
- ★FEATURES 3 TRAP DOORS & A CRANK SCRAPER



SMALL BLOCK FORD PICKUP

- ★FITS #413-220 OIL PAN & STOCK SBF OIL PUMPS
- ★HIGH VOLUME



PART #413-200

# OIL PAN RAIL GIRDLE

- ★FITS 57-79 SBC BLOCKS
- ★SPREADS TORQUE OVER LARGER AREA TO HELP SEAL THE PAN TO THE BLOCK REGARDLESS OF THE GASKET USED



LEFT HAND DIPSTICK

★.125" THICK

PART #413-020

# OIL PAN GASKET SET

- ★FEL-PRO HIGH PERFORMANCE OIL PAN GASKET SET FOR 1975-79 SBC V8 265, 283, 302, 307, 327, 350, & 400, INCLUDING RACE ENGINES, WITH LEFT HAND DIPSTICK

★THICK FRONT SEAL

★3/32" THICK

PART #FEL 1803

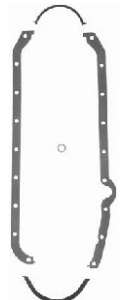

Place your order at (479) 646-6988, Fax to (479) 646-5939, or visit [www.southwestspeed.com](http://www.southwestspeed.com)



# DIPSTICKS WITH TUBE

- ★ FITS SMALL BLOCK CHEVY'S
- ★ AVAILABLE TO PRESS IN THE BLOCK OR SCREW IN RACING PANS
- ★ CHROME PLATED CONSTRUCTION
- ★ MAKES CHECKING OIL A LOT EASIER

PRESS-IN SHOWN



DESCRIPTION	PART #
PRESS-IN DIPSTICK & TUBE, STOCK	411-448
SCREW-IN DIPSTICK & TUBE, RACE	413-199

# OIL FILTERS

## WIX SCREW-ON FILTERS

- ★ HIGH EFFICIENCY ENDURANCE OIL FILTERS
- ★ HIGH BURST PRESSURE CAN & HIGH TEMP. RUBBER COMPONENTS
- ★ CHEVY THREADS ARE 13/16"-16 & FORD/CHRYSLER THREADS ARE 3/4"-16



DESCRIPTION	PART #
CHEVY, 4 1/2" TALL	WFP 51069R
CHEVY, 5 1/2" TALL	WFP 51061R
CHEVY, 5 1/2" TALL W/ANTI-DRAIN	WFP 51060R
CHEVY CRATE, 3 5/16" W/ANTI-DRAIN	WFP 57099
FORD/CHRYSLER, 5 1/2" W/ANTI-DR.	WFP 51515R
RACING FILTER, REMOTE MOUNT, 6"*	WFP 51222R
RACING FILTER, REMOTE MOUNT, 6"*	WFP 57006R

\*51222R HAS 1 1/2"-12 THREADS, WHILE #57006R HAS 1 1/2"-16

# INLINE SCREENED FILTERS

- ★ PREVENTS METAL CHIPS & OTHER DEBRIS FROM ENTERING DRY SUMP PUMPS, REAR END PUMPS, & OTHER OIL SYSTEM COMPONENTS
- ★ LIGHTWEIGHT ALUMINUM HOUSING & 304 STAINLESS STEEL SCREEN USING .018" DIAMETER, 16 MESH WIRE



DESCRIPTION	PART #
INLINE FILTER, -10AN FITTINGS	MOR 23850
INLINE FILTER, -12AN FITTINGS	MOR 23860
REPLACEMENT FILTER ELEMENT	MOR 97050

# PRE-FILTER OIL SCREEN

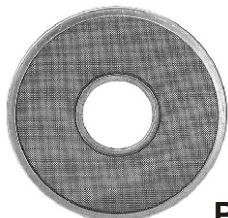

- ★ FITS ALL SBC, BBC, AND 90° V6 CHEVY ENGINES W/ SPIN-ON OIL FILTERS
- ★ TRAPS DEBRIS BEFORE IT ENTERS THE FILTER ELEMENT UNDETECTED

PART #MOR 23845

# REMOTE OIL FILTER MOUNTS

- ★ MADE FROM CAST ALUMINUM
- ★ TAPPED FOR 1/2" NPT INLET & OUTLET
- ★ USES SPIN-ON STYLE OIL FILTERS

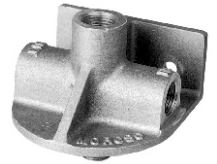

DESCRIPTION	PART #
ACCEPTS FORD OR CHRYSLER V8 FILTERS; FLOW: IN RIGHT, OUT LEFT	MOR 23700
ACCEPTS FORD OR CHRYSLER V8 FILTERS; FLOW: IN LEFT, OUT RIGHT	MOR 23710
ACCEPTS CHEVY V8 FILTERS; FLOW: IN RIGHT, OUT LEFT	MOR 23750
ACCEPTS CHEVY V8 FILTERS; FLOW: IN LEFT, OUT RIGHT	MOR 23760

# LARGE DIAMETER

- ★ TWO 3/8"-16 THREADED MOUNTING HOLES
- ★ INCLUDES 2 ADAPTERS TO ACCEPT A LARGE RANGE OF LARGE DIAMETER FILTERS
- ★ -12AN INLET AND OUTLET PORTS



PART #MOR 23766

# OIL FILTER BYPASS PLATE



- ★ DIRECTS THE OIL TO A REMOTE OIL FILTER OR COOLER
- ★ BILLET ALUMINUM CONSTRUCTION
- ★ -10 AN INLET & -10 AN OUTLET ON BOTTOM
- ★ FITS SMALL BLOCK CHEVY FILTER LOCATION

PART #413-290

# OIL FILTER CUTTER

- ★ LIGHTWEIGHT ALUMINUM
- ★ ROLLER BEARINGS HELP CUTTING TOOL GLIDE AROUND FILTER ALMOST EFFORTLESSLY
- ★ ADJUSTABLE TO FIT ALMOST ALL FILTER SIZES



PART #LON 77750

# FILTER ROCK GUARD & COOLER

- ★ LIGHTWEIGHT ALUMINUM
- ★ ADJUSTS TO FIT MOST FILTERS
- ★ EASY INSTALLATION
- ★ COOLS OIL AND PROTECTS FILTER FROM FLYING DEBRIS



PART #413-299

Place your order at (479) 646-6988, Fax to (479) 646-5939, or visit [www.southwestspeed.com](http://www.southwestspeed.com)

# STOCK & RACING OIL PUMPS

- ★100% PRESSURE TESTED TO STRINGENT QUALITY CONTROL SPECIFICATIONS
- ★MANUFACTURED FROM HIGH-QUALITY STEEL WITH ALL NEW COMPONENTS USING A PROPRIETARY CASTING PROCESS
- ★PRECISION-MACHINED STEEL GEARS
- ★PRECISION-GROUND SHAFTS



DESCRIPTION	PART #
M55 SBC	PCE 2601
M55HV SBC HIGH VOLUME	PCE 2602
M57 FORD 390-428 (FE)	PCE 2603
M62 CHEVY 4 CYL. & INLINE 6 CYL.	PCE 2604
M62C PONTIAC 151 77-93	PCE 2605
M066C CHRYSLER SLANT 6 CYL.	PCE 2606
M68 FORD 289-302W	PCE 2607
M68HV FORD 289-302W HIGH VOLUME	PCE 2608
M72 CHRYSLER 273-360	PCE 2609
M72HV CHRYSLER 273-360 HIGH VOL.	PCE 2610
M74 FORD INLINE 6 CYL.	PCE 2611
M77 BBC 396-454	PCE 2612
M77HV BBC 396-454 HIGH VOLUME	PCE 2613
M81A DODGE 2.5L, JEEP, AMC, EAGLE	PCE 2614
M83 FORD 351W	PCE 2615
M84A FORD 302-351C	PCE 2616
M86C FORD 4 CYL.	PCE 2617
M87 FORD & MERCURY V6 & SAAB V4	PCE 2618
M95B CHEVY 60 DEGREE V6, 5/8" DIA.	PCE 2619
M97 STANDARD OIL PUMP	PCE 2620
M98 CHEVY 4 CYL. 2.0/2.2L	PCE 2621
M102 FORD 4 CYL.	PCE 2622
M118 CHRYSLER 4 CYL.	PCE 2623
M127 FORD 4 CYL.	PCE 2624
M128 FORD 6 CYL.	PCE 2625
M134 CHEVY 60 DEGREE V6, 3/8" DIA.	PCE 2626
M155 CHEVY V6 & V8 VORTEC LATE MOD	PCE 2627
M246 FORD V6 3.8/4.2L	PCE 2628
M248 CHEVY 4 CYL. 2.2L	PCE 2629

# RACING ACCUMULATOR

- ★3 QUART RACING ACCUMULATOR
- ★PROVIDES AN INSTANTANEOUS SUPPLY OF OIL WHEN PRESSURE FALLS BELOW A SAFE LEVEL
- ★STORES OIL UNDER PRESSURE & AUTOMATICALLY RELEASES IT TO THE MAIN GALLERIES WHEN OIL PRESSURE DROPS
- ★MOROSO #23920 MOUNT KIT ALSO AVAILABLE



**PART #**  
**MOR 23900**

# OIL PUMP STUD KIT



**PART #**  
**ARP 230-7001**

- ★FOR SBC PUMPS
- ★BLACK OXIDIZED
- ★INCLUDES FLAT WASHER & HEX HEAD NUT
- ★RATED 170,000 PSI TENSILE STRENGTH

# OIL PUMP PRIMER

- ★FITS MOST CHEVY ENGINES
- ★THIS IS A PREMIUM PRODUCT WITH THE ALUMINUM LOWER ALIGNMENT COLLAR THAT WILL REPLICATE THE DISTRIBUTOR LOCATION, WHICH ALLOWS THE OIL TO BE PUMPED TO THE TOP SIDE OF THE ENGINE IN A MUCH QUICKER FASHION
- ★THE ONLY CORRECT WAY TO BUILD UP OIL PRESSURE IN A NEW ENGINE BEFORE INITIAL STARTING
- ★REMOVE THE DISTRIBUTOR & INSERT THE PRIMER TO ENGAGE THE END OF THE OIL PUMP DRIVE
- ★THE OTHER END OF THE PRIMER FITS A 1/4" CHUCK IN A HAND DRILL TO DRIVE THE OIL PUMP



**PART #**  
**705-0009**

# OIL COOLING TUBE

- ★THREE FEET LONG PRE-THREADED TUBE X 1 3/4" OUTSIDE DIAMETER WITH 3/4" PIPE THREAD ON BOTH ENDS OF TUBE

**PART #HRE E-2003**

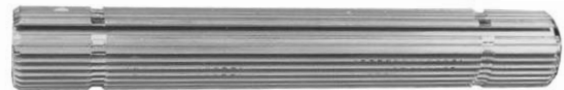

# VALVE COVER PARTS

## SBC STUD & NUT SET

- ★WIDE SHOULDER NUTS PROVIDE EVEN TORQUE ON GASKETS
- ★GREAT FOR USE WHEN SPACE IS CRITICAL OR IF THE VALVE COVER NUTS MUST BE SNUGGED DOWN TIGHTER THAN WING NUTS WILL ALLOW

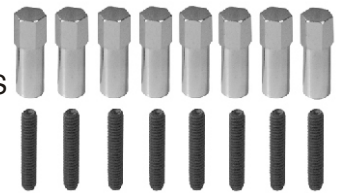

**PART #411-392**

- ★INCLUDES EIGHT CHROME-PLATED STEEL 1/2" HEX HEAD X 1 3/8" LONG NUTS AND EIGHT 1/4"-20 X 1 3/8" LONG STUDS

## SBC LT SERIES STUDS

- ★VALVE COVER BOLT SET TO FIT SMALL BLOCK CHEVY'S WITH LT SERIES HEADS
- ★INCLUDES EIGHT 5" LONG COUNTER-SUNK BOLTS

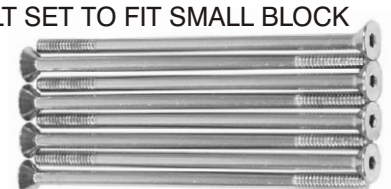

**PART #411-390**

Place your order at (479) 646-6988, Fax to (479) 646-5939, or visit [www.southwestspeed.com](http://www.southwestspeed.com)

## VALVE COVERS W/ TUBES SMALL BLOCK CHEVY STEEL - GOLD PLATED

- ★TALL, GOLD PLATED, STEEL VALVE COVERS
- ★DUAL 1 3/8" BAFFLED BREATHER TUBES ON THE LEFT SIDE



**PART #411-410**

## ALUMINUM - POLISHED

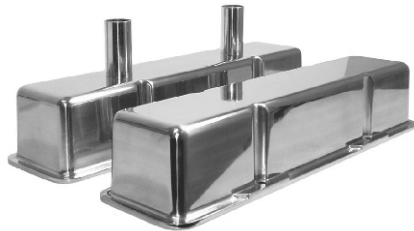

- ★TALL, CAST ALUMINUM POLISHED VALVE COVERS
- ★DUAL 1 3/8" BAFFLED BREATHER TUBES ON THE LEFT SIDE

**PART #411-411**

## ALUMINUM - BLACK

- ★TALL, CAST ALUMINUM BLACK VALVE COVERS
- ★DUAL 1 3/8" BAFFLED BREATHER TUBES ON THE LEFT SIDE

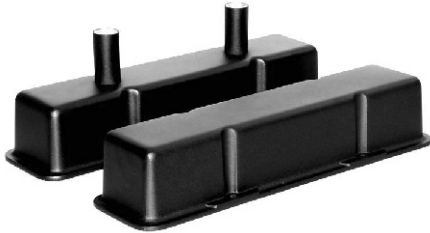

**PART #411-412**

## VALVE COVERS W/ TUBES CHEVY - LT SERIES HEADS ALUMINUM - POLISHED

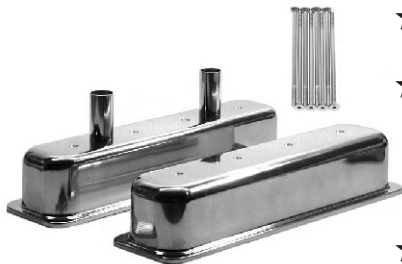

**PART #411-421**

- ★TALL, POLISHED ALUMINUM
- ★DUAL 1 3/8" BAFFLED BREATHER TUBES ON LEFT SIDE
- ★SOLD COMPLETE WITH STUDS

LT SERIES VALVE COVER BOLT SET, 8 PIECES: #411-390

NOTE: FOR A CONSTANT STREAM OF NEW PRODUCTS & UP-TO-THE-SECOND PRICING, VISIT [WWW.SOUTHWESTSPEED.COM](http://WWW.SOUTHWESTSPEED.COM)

## VALVE COVERS - SMALL BLOCK FORD STEEL - GOLD PLATED

- ★TALL, GOLD PLATED, STEEL VALVE COVERS
- ★DUAL 1 1/2" BAFFLED BREATHER TUBES ON THE LEFT SIDE



**PART #411-415**

## ALUMINUM - POLISHED



- ★TALL, POLISHED ALUMINUM
- ★DUAL 1 3/8" BAFFLED BREATHER TUBES ON THE LEFT SIDE

**PART #411-416**

## ALUMINUM - POLISHED W/ NO HOLES

- ★TALL, CAST ALUMINUM VALVE COVERS
- ★NO BREATHER HOLES



**PART #411-417**

## VALVE COVERS - BIG BLOCK CHEVY ALUMINUM - POLISHED



- ★TALL, CAST ALUMINUM POLISHED VALVE COVERS
- ★DUAL 1 3/8" BAFFLED BREATHER TUBES ON THE LEFT SIDE

**PART #411-414**

## STEEL - STAMPED, TALL

- ★INCLUDES 2 BREATHER/FILLER CAP GROMMETS AND 1 BAFFLED & 1 NON-BAFFLED PCV GROMMET
- ★CHROME PLATED



DESCRIPTION	PART #
CHROME STAMPED STEEL	MOR 68110
CHROME STAMPED STEEL, BAFFLED	MOR 68111

NOTE: VALVE COVERS WITH BAFFLES WILL NOT CLEAR STUD GIRDLES OR SOME SHAFT ROCKER ASSEMBLIES.

Place your order at (479) 646-6988, Fax to (479) 646-5939, or visit [www.southwestspeed.com](http://www.southwestspeed.com)



# ALUMINUM POLISHED VALVE COVERS

- ★ MADE FROM HIGH-QUALITY ALUMINUM WITH A POLISHED FINISH, GUARANTEED TO DRAW ATTENTION TO YOUR ENGINE COMPONENTS



- ★ TALL DESIGNED COVERS
- ★ ALL COVERS COME WITH BREATHER HOLE

DESCRIPTION	PART #
SBC	PCE 3251
SBC (CHROME FINISH)	PCE 3251C
SBC, BALL MILLED	PCE 3252
SBC, FLAMED	PCE 3253
SBC, CENTER BOLT	PCE 3254
SBC, CENTER BOLT, BALL MILLED	PCE 3255
SBC, CENTER BOLT, FLAMED	PCE 3256
SBC, CIRCLE TRACK	PCE 3257
BBC	PCE 3258
BBC (CHROME FINISH)	PCE 3258C
BBC, BALL MILLED	PCE 3259
BBC, FLAMED	PCE 3260
SB FORD	PCE 3261
SB FORD, BALL MILLED	PCE 3262
SB FORD, FLAMED	PCE 3263
BB FORD 351-400M	PCE 3264
BB FORD 351-400M, BALL MILLED	PCE 3264BM
BB FORD 429-460	PCE 3265
BB FORD 429-460, BALL MILLED	PCE 3265BM
308VN LATE	PCE 3266

# BILLET BREATHERS

- ★ 2 PIECE DESIGN FOR EASY ACCESS TO FILTER ELEMENT
- ★ GROMMET INCLUDED
- ★ MADE FROM 6061-T6 BILLET ALUMINUM



DESCRIPTION	PART #
BILLET BREATHER WITH TUBE	PCE 3319PCV
BILLET BREATHER	PCE 3320

NOTE: SEE PAGE 116 FOR MANY MORE VALVE COVER BREATHERS, AS WELL AS VENT BREATHERS

# SBC HOLD DOWNS CHROME

- ★ SMALL BLOCK CHEVY
- ★ CHROME PLATED STEEL
- ★ SPECIALLY DESIGNED TO SPREAD THE FASTENER LOAD OVER A LARGER AREA OF THE VALVE COVER FLANGE TO ELIMINATE FLANGE DISTORTION & SUBSEQUENT OIL LEAKAGE
- ★ 8 PIECES IN SET, ENOUGH TO DO 2 COVERS

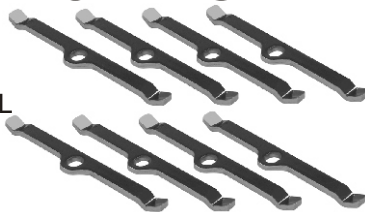

PART #411-396

# FABRICATED SHEET METAL VALVE COVERS

- ★ ALUMINUM SHEET METAL VALVE COVERS
- ★ MADE FROM HIGH-GRADE ALUMINUM & INCLUDE BILLET RAILS, PROVIDING AN EXCELLENT SEAL & HIGH STRENGTH TO ANY PERFORMANCE ENGINE
- ★ ALL COVERS ARE TALL EXCEPT FOR THE MOPAR/CHRYSLER'S & ALL HAVE BREATHER HOLES EXCEPT THE ONES LISTED



DESCRIPTION	PART #
SBC	PCE 3301
SBC (CHROME FINISH)	PCE 3301C
SBC ANODIZED RED	PCE 3301A
SBC PAINTED RED	PCE 3301D
SBC POLISHED	PCE 3301P
SBC, WITHOUT HOLES	PCE 3301W/O
SBC, CIRCLE TRACK	PCE 3302
SBC, CIRCLE TRACK, POLISHED	PCE 3302P
BBC	PCE 3303
BBC (CHROME FINISH)	PCE 3303C
BBC POLISHED	PCE 3303P
BBC, WITHOUT HOLES	PCE 3303W/O
BBC, CIRCLE TRACK	PCE 3304
SB FORD	PCE 3305
SB FORD (CHROME FINISH)	PCE 3305C
SB FORD POLISHED	PCE 3305P
SB FORD, WITHOUT HOLES	PCE 3305W/O
SB FORD, CIRCLE TRACK	PCE 3306
MOPAR 318, SB CHRYSLER	PCE 3308
MOPAR 318, SB CHRYSLER, POLISH.	PCE 3308P
MOPAR 440, BB CHRYSLER	PCE 3309
MOPAR 440, BB CHRYSLER, POLISH.	PCE 3309P
SBC DART, ROUGH CAST STYLE	PCE 5701

# VALVE COVER GASKETS

- ★ AVAILABLE IN DURABLE PERMALIGN RUBBER, PERMALIGN CORK, & HIGH-TEMPERATURE CORK
- ★ "PERMALIGN" MEANS THAT THEY CONTAIN A STEEL CORE
- ★ 3/16" THICK GASKETS FOR SBC, BBC, CHEVY WITH LT SERIES HEADS, & SB FORD
- ★ SOLD IN PAIRS

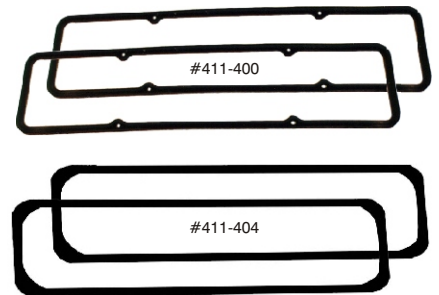

DESCRIPTION	PART #
SBC GASKETS, PERMALIGN RUBBER	411-400
SBC GASKETS, PERMALIGN CORK	411-402
SBC GASKETS, CORK	411-403
CHEVY LT SERIES GASKETS, CORK	411-404
CHEVY LT SERIES GASKETS, RUBBER	411-4042
BBC GASKETS, PERMALIGN RUBBER	411-405
SBF GASKETS, PERMALIGN RUBBER	411-406

Place your order at (479) 646-6988, Fax to (479) 646-5939, or visit [www.southwestspeed.com](http://www.southwestspeed.com)

# SBC ALUMINUM CYLINDER HEADS

- ★ HIGH PERFORMANCE ALUMINUM CYLINDER HEADS FOR SMALL BLOCK CHEVY'S
- ★ FEATURING HARDENED SEATS & BRONZE VALVE GUIDES
- ★ MULTI-ANGLE SEAT DESIGN
- ★ AVAILABLE AS A BARE HEAD OR COMPLETE WITH VALVES, SPRINGS, RETAINERS, KEEPERS, STUDS, & GUIDE PLATES
- ★ ALSO AVAILABLE POLISHED, AS WELL AS PROFESSIONALLY CNC PORTED
- ★ STRAIGHT OR ANGLE PLUG
- ★ CONSISTENT WITH A COMBUSTION CHAMBER OF 64CC & INTAKE RUNNER OF 180CC TO 215CC

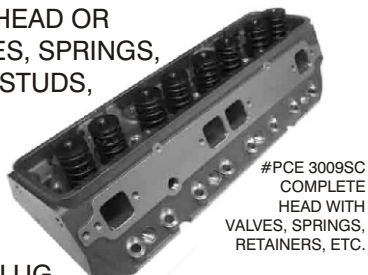
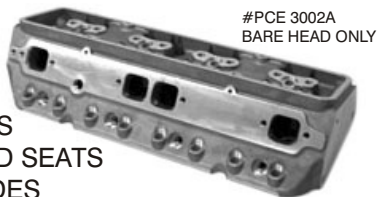

DESCRIPTION	COMBUST. CHAMBER	INTAKE RUNNER	PLUGS	PART #
<b>BARE HEADS ONLY</b>				
BARE HEAD	64CC	190CC	ANGLE	PCE 3002A
BARE HEAD	64CC	190CC	STRGHT	PCE 3002S
BARE HEAD	64CC	210CC	ANGLE	PCE 3003A
BARE HEAD	64CC	210CC	STRGHT	PCE 3003S
<b>POLISHED BARE HEADS ONLY</b>				
BARE HEAD	64CC	195CC	ANGLE	PCE 3002AP
BARE HEAD	64CC	195CC	STRGHT	PCE 3002SP
BARE HEAD	64CC	215CC	ANGLE	PCE 3003AP
BARE HEAD	64CC	215CC	STRGHT	PCE 3003SP
<b>CNC PORTED BARE HEADS ONLY</b>				
BARE HEAD	64CC	180CC	ANGLE	PCE 3006A
BARE HEAD	64CC	180CC	STRGHT	PCE 3006S
BARE HEAD	64CC	195CC	ANGLE	PCE 3007A
BARE HEAD	64CC	195CC	STRGHT	PCE 3007S
BARE HEAD	64CC	205CC	ANGLE	PCE 3008A
BARE HEAD	64CC	205CC	STRGHT	PCE 3008S
BARE HEAD	64CC	215CC	ANGLE	PCE 3009A
BARE HEAD	64CC	215CC	STRGHT	PCE 3009S
<b>COMPLETE HEADS, ASSEMBLED</b>				
COMPLT. HD	64CC	190CC	ANGLE	PCE 3002AC
COMPLT. HD	64CC	190CC	STRGHT	PCE 3002SC
COMPLT. HD	64CC	210CC	ANGLE	PCE 3003AC
COMPLT. HD	64CC	210CC	STRGHT	PCE 3003SC
<b>POLISHED, COMPLETE HEADS, ASSEMBLED</b>				
COMPLT. HD	64CC	195CC	ANGLE	PCE 3002APC
COMPLT. HD	64CC	195CC	STRGHT	PCE 3002SPC
COMPLT. HD	64CC	215CC	ANGLE	PCE 3003APC
COMPLT. HD	64CC	215CC	STRGHT	PCE 3003SPC
<b>CNC PORTED, COMPLETE HEADS, ASSEMBLED</b>				
COMPLT. HD	64CC	180CC	ANGLE	PCE 3006AC
COMPLT. HD	64CC	180CC	STRGHT	PCE 3006SC
COMPLT. HD	64CC	195CC	ANGLE	PCE 3007AC
COMPLT. HD	64CC	195CC	STRGHT	PCE 3007SC
COMPLT. HD	64CC	205CC	ANGLE	PCE 3008AC
COMPLT. HD	64CC	205CC	STRGHT	PCE 3008SC
COMPLT. HD	64CC	215CC	ANGLE	PCE 3009AC
COMPLT. HD	64CC	215CC	STRGHT	PCE 3009SC

# SBC & BBC ALUMINUM CYLINDER HEADS

- ★ HIGH PERFORMANCE ALUMINUM HEADS
- ★ AVAILABLE AS A BARE HEAD OR COMPLETE WITH VALVES, SPRINGS, RETAINERS, KEEPERS, STUDS, & GUIDE PLATES

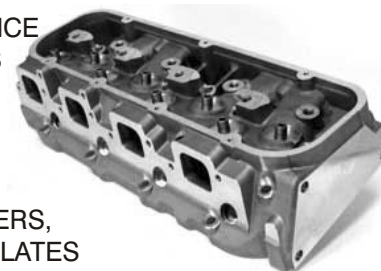

DESCRIPTION	COMBUST. CHAMBER	INTAKE RUNNER	PART #
<b>BARE HEADS ONLY</b>			
SBC LATE VORTEC	64CC	190CC	PCE 3011
SBC LATE LS1	64CC	190CC	PCE 3016
BBC - 396	115CC	310CC	PCE 3021-396
BBC - 454	115CC	320CC	PCE 3021
<b>CNC PORTED BARE HEADS ONLY</b>			
SBC LATE LS1	64CC	190CC	PCE 3017
BBC STG 1			PCE 3026
BBC STG 2			PCE 3027
BBC STG 3	115CC	360CC	PCE 3028
<b>COMPLETE HEADS, ASSEMBLED</b>			
SBC LATE VORTEC	64CC	190CC	PCE 3011C
SBC LATE LS1	64CC	190CC	PCE 3016C
BBC - 396	115CC	310CC	PCE 3021-396C
BBC - 454	115CC	320CC	PCE 3021C
<b>CNC PORTED, COMPLETE HEADS, ASSEMBLED</b>			
SBC LATE LS1	64CC	190CC	PCE 3017C
BBC STG 1			PCE 3026C
BBC STG 2			PCE 3027C
BBC STG 3	115CC	360CC	PCE 3028C

# MISC. ALUMINUM CYLINDER HEADS

- ★ AVAILABLE AS A BARE HEAD OR COMPLETELY ASSEMBLED WITH VALVES, SPRINGS, RETAINERS, KEEPERS, ETC.
- ★ ALSO AVAILABLE PROFESSIONALLY CNC PORTED



DESCRIPTION	COMBUST. CHAMBER	INTAKE RUNNER	PART #
<b>BARE HEADS ONLY</b>			
CHRY. 4 CYL. 2.2/2.5			PCE 3141
CHRYSLER 440	72CC	280CC	PCE 3065
TOYOTA 4 CYL. 22R			PCE 3151
HONDA 4 CYL.			PCE 3161
HONDA VTEC			PCE 3162
<b>CNC PORTED BARE HEADS ONLY</b>			
CHRYSLER 440	72CC	280CC	PCE 3068
HONDA VTEC			PCE 3163
<b>COMPLETE HEADS, ASSEMBLED</b>			
CHRYSLER 440	72CC	280CC	PCE 3065C
TOYOTA 4 CYL. 22R			PCE 3151C
<b>CNC PORTED, COMPLETE HEADS, ASSEMBLED</b>			
CHRYSLER 440	72CC	280CC	PCE 3068C

Place your order at (479) 646-6988, Fax to (479) 646-5939, or visit [www.southwestspeed.com](http://www.southwestspeed.com)

# FORD ALUMINUM CYLINDER HEADS

★ HIGH PERFORMANCE ALUMINUM HEADS

★ FEATURING HARDENED SEATS & BRONZE VALVE GUIDES

★ AVAILABLE AS A BARE HEAD OR COMPLETE WITH VALVES, SPRINGS, RETAINERS, KEEPERS, STUDS, & GUIDE PLATES

★ ALSO AVAILABLE POLISHED, AS WELL AS PROFESSIONALLY CNC PORTED

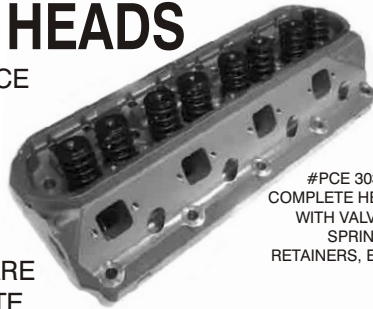

#PCE 3038C  
COMPLETE HEAD  
WITH VALVES,  
SPRINGS,  
RETAINERS, ETC.



#PCE 3044  
BARE HEAD ONLY

# SBC CAST IRON CYLINDER HEADS

★ HIGH PERFORMANCE CAST IRON CYLINDER HEADS FOR SMALL BLOCK CHEVY'S

★ MANUFACTURED FROM 80-60-06 NODULAR CAST IRON MATERIAL

★ 15% STRONGER & RE-DESIGNED PORTS PROVIDE MORE FLOW & STRENGTH OVER STOCK CAST IRON HEADS

★ AVAILABLE AS A BARE HEAD OR COMPLETE WITH VALVES, SPRINGS, RETAINERS, KEEPERS, STUDS, & GUIDE PLATES

★ STRAIGHT OR ANGLE PLUG

★ CONSISTENT WITH A COMBUSTION CHAMBER OF 64CC & INTAKE RUNNER 190CC



#PCE 3101S BARE HEAD ONLY



#PCE 3101AC  
COMPLETE HEAD WITH  
VALVES, SPRINGS,  
RETAINERS, ETC.

DESCRIPTION	COMBUST. CHAMBER	INTAKE RUNNER	PART #
<b>BARE HEADS ONLY</b>			
SB FORD	64CC	175CC	PCE 3036
SB FORD	64CC	190CC	PCE 3037
SB FORD	64CC	210CC	PCE 3038
FORD 351C 4V	74CC	210CC	PCE 3061
BB FORD 429/460	95CC	300CC	PCE 3051
<b>POLISHED BARE HEADS ONLY</b>			
SB FORD	64CC	175CC	PCE 3036P
SB FORD	64CC	190CC	PCE 3037P
SB FORD	64CC	210CC	PCE 3038P
<b>CNC PORTED BARE HEADS ONLY</b>			
SB FORD	64CC	180CC	PCE 3041
SB FORD	64CC	195CC	PCE 3042
SB FORD	64CC	205CC	PCE 3043
SB FORD	64CC	215CC	PCE 3044
SB FORD	64CC	230CC	PCE 3045
FORD 351C 4V	74CC	233CC	PCE 3062
BBF 429/460 STG 1			PCE 3056
BBF 429/460 STG 2			PCE 3057
BBF 429/460 STG 3	95CC	300CC	PCE 3058
<b>COMPLETE HEADS, ASSEMBLED</b>			
SB FORD	64CC	175CC	PCE 3036C
SB FORD	64CC	190CC	PCE 3037C
SB FORD	64CC	210CC	PCE 3038C
FORD 351C 4V	74CC	210CC	PCE 3061C
BB FORD 429/460	95CC	300CC	PCE 3051C
<b>POLISHED, COMPLETE HEADS, ASSEMBLED</b>			
SB FORD	64CC	175CC	PCE 3036PC
SB FORD	64CC	190CC	PCE 3037PC
SB FORD	64CC	210CC	PCE 3038PC
<b>CNC PORTED, COMPLETE HEADS, ASSEMBLED</b>			
SB FORD	64CC	180CC	PCE 3041C
SB FORD	64CC	195CC	PCE 3042C
SB FORD	64CC	205CC	PCE 3043C
SB FORD	64CC	215CC	PCE 3044C
SB FORD	64CC	230CC	PCE 3045C
FORD 351C 4V	74CC	233CC	PCE 3062C
BBF 429/460 STG 1			PCE 3056C
BBF 429/460 STG 2			PCE 3057C
BBF 429/460 STG 3	95CC	300CC	PCE 3058C

DESCRIPTION	COMBUST. CHAMBER	INTAKE RUNNER	PLUGS	PART #
<b>BARE HEADS ONLY</b>				
SBC	64CC	190CC	ANGLE	PCE 3101A
SBC	64CC	190CC	STRGHT	PCE 3101S
LATE VORT.*	64CC	190CC	STRGHT	PCE 3111
<b>COMPLETE HEADS, ASSEMBLED</b>				
SBC	64CC	190CC	ANGLE	PCE 3101AC
SBC	64CC	190CC	STRGHT	PCE 3101SC
LATE VORT.*	64CC	190CC	STRGHT	PCE 3111C

\*SBC LATE VORTEC

# BBC, FORD, & OTHER CAST IRON CYLINDER HEADS

★ HIGH PERFORMANCE CAST IRON CYLINDER HEADS

★ MANUFACTURED FROM 80-60-06 NODULAR CAST IRON MATERIAL

★ 15% STRONGER & RE-DESIGNED PORTS PROVIDE MORE FLOW & STRENGTH OVER STOCK CAST IRON HEADS



DESCRIPTION	COMBUST. CHAMBER	INTAKE RUNNER	PART #
<b>BARE HEADS ONLY</b>			
BBC 427			PCE 3181
GM 6.2 DIESEL			PCE 3117
SB FORD	60CC	190CC	PCE 3116
BB FORD 429/460			PCE 3121
FORD V6 4.0L*			PCE 3126
CHRYSLER 318/360			PCE 3131

\*TEAR DROP CHAMBER 90-94

Place your order at (479) 646-6988, Fax to (479) 646-5939, or visit [www.southwestspeed.com](http://www.southwestspeed.com)



# HIGH PERFORMANCE ALUMINUM INTAKE MANIFOLDS

- ★ CNC MACHINED FOR THE VERY BEST QUALITY
- ★ EACH MANIFOLD HAS CHARACTERISTICS THAT MAKE IT IDEAL FOR THE PARTICULAR APPLICATION, WHETHER IT BE A RACE CAR, A DAILY DRIVER FOR THE STREET, OR A HIGH PERFORMANCE STREET/STRIP MACHINE



DESCRIPTION	PART #
SBC SINGLE PLANE, RACING	PCE 3203
SBC SINGLE, RACING, POLISHED	PCE 3203P
SBC DUAL PLANE, STREET	PCE 3201
SBC DUAL PLANE, STREET/STRIP	PCE 3202
SBC FABRICATED	PCE 3200F
SBC CHEVY 350-400 WEBER-STYLE	PCE 3204
SBC GEN1 & VORTEC, DUAL PL, STRT.	PCE 3207
SBC GEN1 & VORTEC, DUAL PL, ST./ST.	PCE 3208
BBC DUAL PLANE	PCE 3209
BBC SINGLE PLANE	PCE 3210
SB FORD DUAL PLANE	PCE 3212
SB FORD SINGLE PLANE	PCE 3213
SB FORD 302W PARKER	PCE 3214
SB FORD 302W PARKER, POLISHED	PCE 3214P
SB FORD 351W DUAL PLANE	PCE 3215
SB FORD 351W SINGLE PLANE	PCE 3216
SB FORD 351W BOSS (FOR PC HEADS)	PCE 3221
BB FORD 351C SINGLE PLANE, STREET	PCE 3217
BB FORD 351C SINGLE PLANE, RACING	PCE 3218
BB FORD 351C SINGLE, POLISHED	PCE 3218P
BB FORD 351C SINGLE, FABRICATED	PCE 3218F
BB FORD 429/460 DUAL PLANE	PCE 3219
BB FORD 429/460 SINGLE PLANE	PCE 3220
HOLDEN 253-308 SINGLE PLANE	PCE 3222H

## LIFTER VALLEY BAFFLE - SBC

- ★ INCREASES HORSEPOWER BY SHIELDING BOTTOM OF INTAKE MANIFOLD FROM HOT OIL
- ★ KEEPS SURPLUS OIL OUT OF VALVE COVERS BY ELIMINATING OIL SPLASH
- ★ MAINTAINS OIL PRESSURE DURING PUSHROD OR ROCKER ARM FAILURE BY KEEPING LIFTERS IN THEIR BORES (EXCEPT WITH ROLLER CAM)
- ★ CANNOT BE USED WITH ROLLER LIFTERS

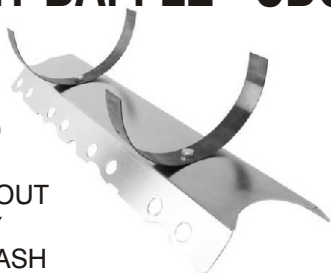

**PART #401-217**

# HEAD BUILD KITS

- ★ KITS COME COMPLETE WITH ALL THE COMPONENTS REQUIRED TO ASSEMBLE PCE HEADS, AS WELL AS OTHER HEADS WITH THE SAME SPECS.
- ★ ONE KIT BUILDS TWO HEADS
- ★ INCLUDES VALVES, CHROMEMOLY RETAINERS, DUAL VALVE SPRINGS, VITON VALVE SEALS, VALVE KEEPERS, SPRING WASHERS, SCREW-IN STUDS, & GUIDE PLATES



DESCRIPTION	PART #
SMALL BLOCK CHEVY BUILD KIT	PCE HBK-SBC
BIG BLOCK CHEVY BUILD KIT	PCE HBK-BBC
CHEVY LS1 BUILD KIT	PCE HBK-LS1
SMALL BLOCK FORD ALUM. HEAD	PCE HBK-SBFA
SMALL BLOCK FORD IRON HEAD	PCE HBK-SBFI
BIG BLOCK FORD BUILD KIT	PCE HBK-BBF
FORD 351C BUILD KIT	PCE HBK-351C
CHRYSLER BUILD KIT	PCE HBK-CHRY

## HEAD STUD KITS & BOLT KITS

- ★ MADE FROM AIRCRAFT QUALITY 8740 HIGH TENSILE STRENGTH CHROMEMOLY STEEL, WHICH CAN WITHSTAND UP TO 190,000 PSI
- ★ EACH KIT COMES COMPLETE WITH HARDWARE

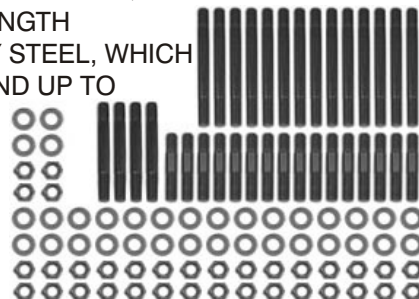

DESCRIPTION	PART #
SBC STUD KIT	PCE 2451
SBC BOLT KIT	PCE 2451-BOLT
BBC STUD KIT	PCE 2452
BBC STUD KIT (PCE 3021 HEADS)	PCE 2452-6100
BBC BOLT KIT	PCE 2452B
FORD 250 STUD KIT	PCE 2453
FORD 302W STUD KIT	PCE 2454
FORD 351W STUD KIT	PCE 2455
FORD 351C STUD KIT	PCE 2456
FORD 460 STUD KIT	PCE 2457
CHRYSLER 260 STUD KIT	PCE 2458
CHRYSLER 318 STUD KIT	PCE 2459
CHRYSLER 440 STUD KIT	PCE 2460
HOLDEN 186/202 STUD KIT	PCE 2461
HOLDEN 253/308 STUD KIT	PCE 2462
HOLDEN 253/308 1/2" STUD KIT	PCE 2463
CHEVY LS1 ON 1997-02, 2 BOLT	PCE 2464
CHEVY LS1 ON 2002-06, 3 BOLT	PCE 2465

NOTE: FOR A CONSTANT STREAM OF NEW PRODUCTS & UP-TO-THE-SECOND PRICING, VISIT [WWW.SOUTHWESTSPEED.COM](http://WWW.SOUTHWESTSPEED.COM)

Place your order at (479) 646-6988, Fax to (479) 646-5939, or visit [www.southwestspeed.com](http://www.southwestspeed.com)

# STAINLESS STEEL VALVES

★ FULLY MACHINED, SWIRL POLISHED STAINLESS STEEL VALVES  
 FEATURE NK-842 STAINLESS  
 INTAKE MATERIAL,  
 XH-426 EXHAUST MATERIAL,  
 HARDENED TIPS, CHROME  
 STRAIGHT STEMS, &  
 DISHED CUPS

- ★ SOLD IN SETS OF 8
- ★ "A" = INTAKE OR EXHAUST VALVE
- ★ "B" = HEAD DIAMETER
- ★ "C" = DISH
- ★ "D" = STEM DIAMETER
- ★ "E" = LENGTH
- ★ "F" = KEEPER GROOVE
- ★ "G" = KEEPER
- ★ "H" = WEIGHT IN GRAMS



# VALVE SPRINGS

★ HIGH PERFORMANCE SPRINGS  
 ARE MANUFACTURED FROM  
 CHROME SILICONE TO TOLERATE  
 MORE LIFT, BUILD  
 COMPRESSION, & LAST LONGER  
 ★ SOLD IN SETS OF 16  
 ★ "A" = SPRING OUTSIDE DIAMETER  
 ★ "B" = MAXIMUM LIFT  
 ★ "C" = SEAT  
 PRESSURE  
 AT  
 INSTALLED  
 HEIGHT



A	B	C	D	E	F	G	H	PART #
<b>SMALL BLOCK CHEVY</b>								
EXH. 1.600"	9°	.3415"	STOCK,	4.951"	.290"	15° x 1/2"	102g	PCE 4301-8
EXH. 1.600"	9°	.3415"	+0.100"	5.065"	.290"	15° x 1/2"	109g	PCE 4302-8
INT. 2.020"	6°	.3415"	STOCK,	4.951"	.290"	10° x 3/8"	114g	PCE 4303-8
INT. 2.020"	5°	.3415"	+0.100"	5.040"	.290"	10° x 3/8"	116g	PCE 4304-8
INT. 2.055"	5°	.3415"	+0.100"	5.040"	.290"	10° x 3/8"	120g	PCE 4305-8
INT. 2.080"	5°	.3415"	+0.100"	5.040"	.290"	10° x 3/8"	126g	PCE 4306-8
INT. 1.950"		.3415"	STOCK,	4.951"				PCE 4310-8
EXH. 1.500"		.3415"	STOCK,	4.951"				PCE 4311-8
<b>BIG BLOCK CHEVY</b>								
EXH. 1.880"	6°	.3415"	STOCK,	5.422"	.250"	10° x 3/8"	122g	PCE 4316-8
EXH. 1.880"	6°	.3415"	+0.100"	5.522"	.250"	10° x 3/8"	124g	PCE 4317-8
EXH. 1.900"	5°	.3415"	STOCK,	5.422"	.250"	10° x 3/8"	123g	PCE 4318-8
EXH. 1.940"	5°	.3415"	STOCK,	5.422"	.250"	10° x 3/8"	124g	PCE 4319-8
INT. 2.190"	5°	.3415"	STOCK,	5.244"	.250"	10° x 3/8"	139g	PCE 4320-8
INT. 2.190"	5°	.3415"	+0.100"	5.344"	.250"	10° x 3/8"	140g	PCE 4321-8
INT. 2.250"	5°	.3415"	STOCK,	5.244"	.250"	10° x 3/8"	140g	PCE 4322-8
INT. 2.250"	5°	.3415"	+0.100"	5.344"	.250"	10° x 3/8"	142g	PCE 4323-8
INT. 2.250"	5°	.3415"	+0.250"	5.494"	.250"	10° x 3/8"	145g	PCE 4324-8
INT. 2.300"	5°	.3415"	STOCK,	5.244"	.250"	10° x 3/8"	143g	PCE 4325-8
INT. 2.300"	5°	.3415"	+0.100"	5.344"	.250"	10° x 3/8"	146g	PCE 4326-8
INT. 2.300"	5°	.3415"	+0.250"	5.494"	.250"	10° x 3/8"	147g	PCE 4327-8
<b>CHEVY LS1</b>								
EXH. 1.570"		8mm	STOCK,					PCE 4312-8
INT. 2.200"		8mm	STOCK,					PCE 4313-8
EXH. 1.620"		8mm						PCE 4314-8
INT. 2.055"		8mm						PCE 4315-8
<b>SMALL BLOCK FORD</b>								
EXH. 1.600"	7°	.3415"	STOCK,	4.911"	.250"	12° x 3/8"	94g	PCE 4331-8
INT. 2.020"	5°	.3415"	STOCK,	4.911"	.250"	12° x 3/8"	113g	PCE 4332-8
<b>FORD 351 CLEVELAND</b>								
EXH. 1.710"	7°	.3415"	STOCK,	5.042"	.250"	10° x 3/8"	108g	PCE 4346-8
INT. 2.190"	7°	.3415"	STOCK,	5.244"	.250"	12° x 3/8"	139g	PCE 4347-8
INT. 2.250"	7°	.3415"	STOCK,	5.244"	.250"	12° x 3/8"	140g	PCE 4348-8
EXH. 1.710"	9°	.3415"	+0.100"	5.167"	.250"	12° x 3/8"	111g	PCE 4349-8
INT. 2.250"	7°	.3415"	+0.100"	5.344"	.250"	12° x 3/8"	142g	PCE 4350-8
<b>BIG BLOCK FORD 429-460</b>								
EXH. 1.760"	9°	.3415"	STOCK,	5.067"	.250"	12° x 3/8"	113g	PCE 4361-8
EXH. 1.760"	9°	.3415"	+0.100"	5.167"	.250"	12° x 3/8"	116g	PCE 4362-8
INT. 2.190"	7°	.3415"	STOCK,	5.244"	.250"	12° x 3/8"	138g	PCE 4363-8
INT. 2.190"	7°	.3415"	+0.100"	5.344"	.250"	12° x 3/8"	140g	PCE 4364-8
INT. 2.250"	7°	.3415"	STOCK,	5.244"	.250"	12° x 3/8"	144g	PCE 4365-8
INT. 2.250"	7°	.3415"	+0.100"	5.344"	.250"	12° x 3/8"	142g	PCE 4366-8

A	B	C	PART #
<b>SBC HI-PERFORMANCE DUAL V.S. SET</b>			
1.450"	.675"	210# at 1.800"	PCE 3005
		225# at 1.750"	
		240# at 1.700"	
		375# at 1.300"	
		390# at 1.250"	
		410# at 1.200"	
		425# at 1.150"	
		440# at 1.100"	
		COIL BIND at 0.970"	
<b>SBC HI-PERFORMANCE DUAL V.S. SET</b>			
1.450"	.725"	140# at 1.800"	PCE 6005
		155# at 1.750"	
		170# at 1.700"	
		305# at 1.300"	
		325# at 1.250"	
		340# at 1.200"	
		355# at 1.150"	
		370# at 1.100"	
		COIL BIND at 0.970"	
<b>BBC HI-PERFORMANCE DUAL V.S. SET</b>			
1.525"	.665"	210# at 1.900"	PCE 7005
		215# at 1.850"	
		240# at 1.800"	
		410# at 1.300"	
		425# at 1.250"	
		430# at 1.200"	
		COIL BIND at 1.050"	
<b>SBC SINGLE VALVE SPRING SET</b>			
1.250"	.600"	120# at 1.900"	PCE 5005
		140# at 1.850"	
		160# at 1.800"	
		340# at 1.300"	
		365# at 1.250"	
		395# at 1.200"	
		COIL BIND at 1.070"	
<b>BBC SINGLE V.S. SET WITH DAMPER</b>			
1.525"	.690"	140# at 1.900"	PCE 8005
		165# at 1.850"	
		180# at 1.800"	
		350# at 1.300"	
		365# at 1.250"	
		380# at 1.200"	
		COIL BIND at 1.160"	

Place your order at (479) 646-6988, Fax to (479) 646-5939, or visit [www.southwestspeed.com](http://www.southwestspeed.com)

## VALVE SPRING SEATS & SHIMS



DESCRIPTION	PART #
VALVE SPRING STEEL SEAT SET	PCE 3561
VALVE SPRING SHIM SET, .030"	PCE 3561-0.3
VALVE SPRING SHIM SET, .050"	PCE 3561-0.5
VALVE SPRING SHIM SET, .100"	PCE 3561-1.0
VALVE SPRING SHIM SET, .150"	PCE 3561-1.5

## VALVE SPRING RETAINERS

★ 4140 CHROMEMOLY STEEL RETAINERS

★ BLACK OXIDE FINISHED FOR SUPERIOR CORROSION & WEAR RESISTANCE

★ SOLD IN SETS OF 16

★ "A" = O.D. OF THE RETAINER

★ "B" = I.D. OF THE OUTER SPRING

★ "C" = I.D. OF THE INNERMOST SPRING



"A"	"B"	"C"	PART #
1.250"	0.870"	0.735"	PCE 4261
1.250"	0.870"	0.650"	PCE 4262
1.400"	1.060"	0.690"	PCE 4263
1.400"	1.047"	0.689"	PCE 4264
1.500"	1.150"	0.870"	PCE 4265
1.500"	1.095"	0.710"	PCE 4266
1.500"	1.180"	0.690"	PCE 4267
1.500"	1.125"	0.745"	PCE 4268
1.500"	1.120"	0.830"	PCE 4269
11/32 VALVE KEEPERS			PCE 4271
11/32 VALVE KEEPERS, 10°			PCE 4271-10
VALVE STEM SEALS			PCE 4272
WEAR CAPS FOR 11/32 VALVES			PCE 4273

## ROCKER ARM STUDS

★ 4140 CHROMEMOLY STEEL STUDS

★ HEAT-TREATED TO A MAXIMUM STRENGTH OF 190,000 PSI

★ SOLD IN SETS OF 16



DESCRIPTION	PART #
3/8" SCREW-IN STUD KIT	PCE 2411
7/16" SCREW-IN STUD KIT	PCE 2412
7/16" SCREW-IN STUD KIT, LONG	PCE 2413

## STUD GIRDLE KITS

★ THESE LIGHTWEIGHT, EASY-TO-INSTALL STUD GIRDLES WILL PREVENT DEFLECTION

★ DOUBLE BAR, 1 1/2" GIRDLES

★ CNC MACHINED FROM 2024 T3511 EXTRUDED ALUMINUM

★ KITS

INCLUDE  
POLY-LOCKS



DESCRIPTION	PART #
SBC, 3/8" STUD GIRDLE KIT	PCE 2351
SBC, 7/16" STUD GIRDLE KIT	PCE 2352
BBC, 7/16" STUD GIRDLE KIT	PCE 2353
SB FORD, 3/8" STUD GIRDLE KIT	PCE 2354
SB FORD, 7/16" STUD GIRDLE KIT	PCE 2355
SB FORD, 7/16" KIT (STD. HEADS)	PCE 2355ST
FORD 460, 7/16" STUD GIRDLE KIT	PCE 2356

## POLY-LOCKS

★ 4140 CHROMEMOLY STEEL POSI-LOCKS

★ HEAT-TREATED TO A MAXIMUM STRENGTH OF 190,000 PSI

★ SOLD IN SETS OF 16



DESCRIPTION	PART #
3/8" POLY-LOCK KIT	PCE 2401
7/16" POLY-LOCK KIT	PCE 2402
3/8" STUD GIRDLE POLY-LOCK KIT	PCE 2403
7/16" STUD GIRDLE POLY-LOCK KIT	PCE 2404

## GUIDE PLATES

★ 5140 CHROMEMOLY STEEL PLATES

★ PLATE SURFACES ARE NITRIDE & BLACK OXIDIZED FOR CORROSION & WEAR RESISTANCE

★ SOLD IN SETS OF 8



DESCRIPTION	PUSH ROD	PART #
CHEVY 262/400, FLAT	3/8"	PCE 4241
CHEVY 262/400, FLAT	5/16"	PCE 4242
CHEVY 262/400, FLAT, 2 PC.	5/16"	PCE 4242-ADJ
CHEVY 305/350, RAISED	3/8"	PCE 4243
CHEVY 305/350, RAISED	5/16"	PCE 4244
CHEVY LS1	3/8"	PCE 4245
CHEVY LS1	5/16"	PCE 4246
CHEVY 396/454	3/8"	PCE 4247
CHEVY 396/454, 2 PIECE	3/8"	PCE 4247-ADJ
CHEVY 396/454	7/16"	PCE 4248
FORD 289/302/351W	3/8"	PCE 4249
FORD 289/302/351W	5/16"	PCE 4250
FORD 351C	3/8"	PCE 4251
FORD 351C	5/16"	PCE 4252
FORD 429/460	3/8"	PCE 4253
FORD 429/460	5/16"	PCE 4254
302W/351W (ROUND HOLE)		PCE 4255
302W/351W (OVAL HOLE)		PCE 4255B

Place your order at (479) 646-6988, Fax to (479) 646-5939, or visit [www.southwestspeed.com](http://www.southwestspeed.com)



## ALUMINUM ROLLER ROCKERS

- ★ EXTRUDED FROM 6061-T6 ALUMINUM
- ★ LARGER NEEDLE BEARING FULCRUM CAN WITHSTAND VALVE SPRING LOADS UP TO 750 PSI, WHILE THE EXTRUDED BODY HAS A TENSILE STRENGTH OVER 60,000 PSI



APPLICATION	ROCKERS	STUDS	PART #
SBC	1.5	3/8"	PCE 2301
SBC	1.5	7/16"	PCE 2302
SBC	1.6	3/8"	PCE 2303
SBC	1.6	7/16"	PCE 2304
BBC	1.7	7/16"	PCE 2305
SB FORD	1.6	3/8"	PCE 2306
SB FORD	1.6	7/16"	PCE 2307
FORD 351C/460	1.73	7/16"	PCE 2308
HOLDEN V8 253/308	1.65	3/8"	PCE 2309
HOLDEN V8 253/308	1.65	7/16"	PCE 2310
CHRYSLER 318	1.5		PCE 2311
CHRYSLER 318	1.6		PCE 2311-1.6
CHRYSLER 440	1.5		PCE 2312
CHRYSLER 440	1.6		PCE 2312-1.6

## STAINLESS STEEL ROLLER ROCKERS

- ★ MANUFACTURED FROM 21M4 HIGH-GRADE STAINLESS STEEL
- ★ GREAT STRENGTH & DURABILITY
- ★ CAPABLE OF WITHSTANDING VALVE SPRING LOADS OVER 750 PSI



APPLICATION	ROCKERS	STUDS	PART #
SBC	1.5	3/8"	PCE 2326
SBC	1.55	3/8"	PCE 2326-1.55
SBC	1.65	3/8"	PCE 2326-1.65
SBC	2.5	3/8"	PCE 2326-2.50
SBC	1.5	7/16"	PCE 2327
SBC	1.65	7/16"	PCE 2327-1.65
SBC	1.6	3/8"	PCE 2328
SBC	1.6	7/16"	PCE 2329
BBC	1.7	7/16"	PCE 2330
BBC	1.73	7/16"	PCE 2330-1.73
BBC	1.8	7/16"	PCE 2330-1.80
SB FORD	1.6	3/8"	PCE 2331
SB FORD	1.6	7/16"	PCE 2332
FORD CLEVE./460	1.73	7/16"	PCE 2333
FORD CLEVE./460	1.8	7/16"	PCE 2333-1.80
HOLDEN V8 253/308	1.65	3/8"	PCE 2334
HOLDEN V8 253/308	1.65	7/16"	PCE 2335
CHRYSLER 318	1.5		PCE 2336
CHRYSLER 318	1.6		PCE 2336-SH
CHRYSLER 440	1.5		PCE 2337
CHRYSLER 440	1.5		PCE 2337-1.5SH
CHRYSLER 440	1.6		PCE 2337-1.6SH
SBC VORTEC	1.5	3/8"	PCE 2338SS
SBC VORTEC	1.6	3/8"	PCE 2338-1.6SS
SBC LS1 (W/ BOLTS)			PCE 2339
SBC LS1 (ADJUST.)			PCE 2340

## ROLLER TIP ROCKERS

- ★ 4340 CHROMEMOLY STEEL ROLLER TIP ROCKERS HAVE LONG SLOTS & ARE FOR HIGH LIFT CAMS TO WITHSTAND VALVE SPRING PRESSURE UP TO 350 PSI
- ★ A SELF-LOCKING NUT & METAL POWDER PIVOT BALL ARE PACKED WITH ROCKER



APPLICATION	ROCKERS	STUDS	PART #
SBC	1.5	3/8"	PCE 2316
SBC	1.5	7/16"	PCE 2317
SBC	1.6	3/8"	PCE 2318
SBC	1.6	7/16"	PCE 2319
BBC	1.7	7/16"	PCE 2320
SB FORD	1.6	3/8"	PCE 2321
SB FORD	1.6	7/16"	PCE 2322
FORD 351C/460	1.73	7/16"	PCE 2323

## ALUMINUM SHAFT MOUNT ROLLER ROCKERS

- ★ EXTRUDED ALUMINUM SHAFT MOUNT ROCKER SYSTEM INCLUDES STEEL SHAFTS WITH PEDESTALS
- ★ FEATURES LARGE NEEDLE BEARINGS & ROLLER TIPS

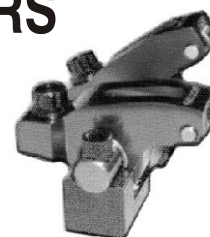

APPLICATION	PART #
SBC, 1.5 ROCKERS	PCE 2341
SBC, 1.5 ROCKERS, +.100" OFFSET	PCE 2341-25
SBC, 1.5 ROCKERS, +.160" OFFSET	PCE 2341-40
SBC, 1.5 ROCKERS, +.250" OFFSET	PCE 2341-62
SBC, 1.6 ROCKERS	PCE 2342
SBC, 1.6 ROCKERS, +.100" OFFSET	PCE 2342-25
SBC, 1.6 ROCKERS, +.160" OFFSET	PCE 2342-40
SBC, 1.6 ROCKERS, +.250" OFFSET	PCE 2342-62
BBC, 1.7 ROCKERS	PCE 2345
SB FORD, 1.6 ROCKERS	PCE 2343
SB FORD, 1.7 ROCKERS	PCE 2344

## STAINLESS STEEL SHAFT MOUNT ROLLER ROCKERS

- ★ EXTRUDED STAINLESS STEEL SHAFT MOUNT ROCKER SYSTEM INCLUDES STEEL SHAFTS WITH PEDESTALS
- ★ FEATURES LARGE NEEDLE BEARINGS & ROLLER TIPS
- ★ FOR EXTREME HIGH PERFORMANCE APPLICATIONS



APPLICATION	PART #
SBC, 1.5 ROCKERS	PCE 2346
SBC, 1.6 ROCKERS	PCE 2347
BBC, 1.7 ROCKERS	PCE 2350
SB FORD, 1.6 ROCKERS	PCE 2348
SB FORD, 1.7 ROCKERS	PCE 2349

Place your order at (479) 646-6988, Fax to (479) 646-5939, or visit [www.southwestspeed.com](http://www.southwestspeed.com)

# PUSH RODS

★ SOLID ONE PIECE RODS MANUFACTURED FROM COLD-FORGED 4130 CHROMEMOLY STEEL WITH 0.080" WALL THICKNESS

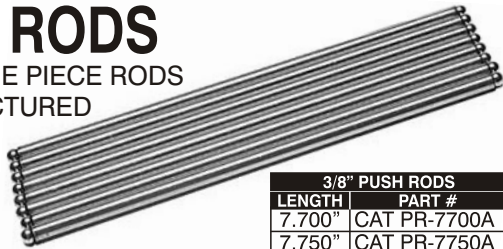

★ A STATE OF THE ART, MULTI-STAGE ROLLING PROCESS WAS USED TO FORM THE PERFECT BALL END SHAPE WITH HIGHER STRENGTH THAN TUBING

★ 5/16" & 3/8" DIAMETER RODS ARE AVAILABLE

★ ALL RODS HAVE 5/16" END BALLS

★ SOLD IN SETS OF 8  
★ STOCK SBC LENGTH IS 7.800"



5/16" PUSH RODS	
LENGTH	PART #
6.000"	CAT PR-6000
6.050"	CAT PR-6050
6.100"	CAT PR-6100
6.150"	CAT PR-6150
6.200"	CAT PR-6200
6.250"	CAT PR-6250
6.300"	CAT PR-6300
6.350"	CAT PR-6350
6.400"	CAT PR-6400
6.450"	CAT PR-6450
6.500"	CAT PR-6500
6.550"	CAT PR-6550
6.600"	CAT PR-6600
6.650"	CAT PR-6650
6.700"	CAT PR-6700
6.750"	CAT PR-6750
6.800"	CAT PR-6800
6.850"	CAT PR-6850
6.900"	CAT PR-6900
6.950"	CAT PR-6950
7.000"	CAT PR-7000
7.050"	CAT PR-7050
7.100"	CAT PR-7100
7.150"	CAT PR-7150
7.200"	CAT PR-7200
7.250"	CAT PR-7250
7.300"	CAT PR-7300
7.350"	CAT PR-7350
7.400"	CAT PR-7400
7.450"	CAT PR-7450
7.500"	CAT PR-7500
7.550"	CAT PR-7550
7.600"	CAT PR-7600
7.650"	CAT PR-7650
7.700"	CAT PR-7700
7.750"	CAT PR-7750
7.800"	CAT PR-7800
7.850"	CAT PR-7850
7.900"	CAT PR-7900
7.950"	CAT PR-7950
8.000"	CAT PR-8000
8.050"	CAT PR-8050
8.100"	CAT PR-8100
8.150"	CAT PR-8150
8.200"	CAT PR-8200
8.250"	CAT PR-8250
8.300"	CAT PR-8300
8.350"	CAT PR-8350
8.400"	CAT PR-8400
8.450"	CAT PR-8450
8.500"	CAT PR-8500
8.550"	CAT PR-8550
8.600"	CAT PR-8600
8.650"	CAT PR-8650
8.700"	CAT PR-8700
8.750"	CAT PR-8750
8.800"	CAT PR-8800
8.850"	CAT PR-8850
8.900"	CAT PR-8900
8.950"	CAT PR-8950
9.000"	CAT PR-9000
9.050"	CAT PR-9050
9.100"	CAT PR-9100
9.150"	CAT PR-9150
9.200"	CAT PR-9200
9.250"	CAT PR-9250
9.300"	CAT PR-9300

3/8" PUSH RODS	
LENGTH	PART #
7.700"	CAT PR-7700A
7.750"	CAT PR-7750A
7.800"	CAT PR-7800A
7.850"	CAT PR-7850A
7.900"	CAT PR-7900A
7.950"	CAT PR-7950A
8.000"	CAT PR-8000A
8.050"	CAT PR-8050A
8.100"	CAT PR-8100A
8.150"	CAT PR-8150A
8.200"	CAT PR-8200A
8.250"	CAT PR-8250A
8.300"	CAT PR-8300A
8.350"	CAT PR-8350A
8.400"	CAT PR-8400A
8.450"	CAT PR-8450A
8.500"	CAT PR-8500A
8.550"	CAT PR-8550A
8.600"	CAT PR-8600A
8.650"	CAT PR-8650A
8.700"	CAT PR-8700A
8.750"	CAT PR-8750A
8.800"	CAT PR-8800A
8.850"	CAT PR-8850A
8.900"	CAT PR-8900A
8.950"	CAT PR-8950A
9.000"	CAT PR-9000A
9.050"	CAT PR-9050A
9.100"	CAT PR-9100A
9.150"	CAT PR-9150A
9.200"	CAT PR-9200A
9.250"	CAT PR-9250A
9.300"	CAT PR-9300A
9.350"	CAT PR-9350A
9.400"	CAT PR-9400A
9.450"	CAT PR-9450A
9.500"	CAT PR-9500A
9.550"	CAT PR-9550A
9.600"	CAT PR-9600A
9.650"	CAT PR-9650A
9.700"	CAT PR-9700A
9.750"	CAT PR-9750A
9.800"	CAT PR-9800A
9.850"	CAT PR-9850A
9.900"	CAT PR-9900A
9.950"	CAT PR-9950A
10.000"	CAT PR-10000A
10.050"	CAT PR-10050A
10.100"	CAT PR-10100A
10.150"	CAT PR-10150A
10.200"	CAT PR-10200A
10.250"	CAT PR-10250A
10.300"	CAT PR-10300A
10.350"	CAT PR-10350A
10.400"	CAT PR-10400A
10.450"	CAT PR-10450A
10.500"	CAT PR-10500A
10.550"	CAT PR-10550A
10.600"	CAT PR-10600A
10.650"	CAT PR-10650A
10.700"	CAT PR-10700A
10.750"	CAT PR-10750A
10.800"	CAT PR-10800A
10.850"	CAT PR-10850A
10.900"	CAT PR-10900A
10.950"	CAT PR-10950A
11.000"	CAT PR-11000A
11.050"	CAT PR-11050A
11.100"	CAT PR-11100A
11.150"	CAT PR-11150A
11.200"	CAT PR-11200A
11.250"	CAT PR-11250A
11.300"	CAT PR-11300A

# HIGH PERFORMANCE LIFTERS

- ★ SEVERAL TYPES OF LIFTERS AVAILABLE
- ★ HYDRAULIC LIFTERS HAVE BEEN MANUFACTURED TO BLEED OFF AT HIGH RPM, ALLOWING THE VALVE TRAIN TO REACH MAXIMUM RPM WITHOUT THE OIL PUMP EFFECT OF STANDARD HYDRAULIC LIFTERS
- ★ MECHANICAL ROLLER LIFTERS ARE SIDE-BARS
- ★ HYDRAULIC ROLLER LIFTERS ARE CENTER BARS
- ★ SOLD IN SETS OF 16



SOLID LIFTERS	PART #
CHEVY SOLID LIFTERS	PCE 2953
FORD SOLID LIFTERS	PCE 2954
SOLID LIFTERS WITH OIL RELEASE	PART #
CHEVY SOLID LIFTERS W/OIL RELEASE	PCE 2962
FORD SOLID LIFTERS W/OIL RELEASE	PCE 2963
HYDRAULIC LIFTERS	PART #
CHEVY ANTI-PUMP-UP HYDRAULIC	PCE 2951-H
BUICK/LATE CHEVY ANTI-PUMP-UP HY.	PCE 2951-B
FORD ANTI-PUMP-UP HYDRAULIC	PCE 2952
MECHANICAL ROLLER LIFTERS	PART #
SBC MECHANICAL ROLLER LIFTERS	PCE 2957
BBC MECHANICAL ROLLER LIFTERS	PCE 2958
SB FORD MECH. ROLLER LIFTERS	PCE 2959
BB FORD MECH. ROLLER LIFTERS	PCE 2960
MOPAR 440 MECH. ROLLER LIFTERS	PCE 2961
HYDRAULIC ROLLER LIFTERS	PART #
SBC HYDRAULIC ROLLER LIFTERS	PCE 2955
BBC HYDRAULIC ROLLER LIFTERS	PCE 2970
FORD HYDRAULIC ROLLER LIFTERS	PCE 2956

# BILLET TIMING CHAIN KITS

- ★ 9 KEY-WAY, DOUBLE ROW TIMING CHAIN KITS ARE CNC MACHINED FROM BILLET STEEL
- ★ ENGINEERED FOR ACCURATE & CONSTANT TIMING
- ★ LIGHTER THAN STOCK



DESCRIPTION	PART #
SBC KIT, TORRINGTON BEARING	PCE 2201
SBC KIT, BRASS WASHER	PCE 2202
SBC-LATE, 1986&UP KIT, BRASS	PCE 2203
BBC, BRASS WASHER	PCE 2204
SB FORD, TORRINGTON BEARING	PCE 2205
SB FORD 302W, BRASS WASHER	PCE 2205BW
SB FORD, BRASS WASHER	PCE 2206
SB FORD-LATE, TORRINGTON	PCE 2207
SB FORD-LATE, BRASS WASHER	PCE 2208
FORD 351C, BRASS WASHER	PCE 2209
FORD 460, TORRINGTON BEARING	PCE 2212
FORD 460, BRASS WASHER	PCE 2210
HOLDEN 253/308	PCE 2211

Place your order at (479) 646-6988, Fax to (479) 646-5939, or visit [www.southwestspeed.com](http://www.southwestspeed.com)



# TIMING GEAR DRIVES

- ★ THESE RUGGED GEAR DRIVES OFFER HIGH-PRECISION TIMING, ELIMINATING CHAIN STRETCH
- ★ THEY ARE CNC MACHINED
- ★ VERY EASY TO INSTALL
- ★ FITS UNDER STOCK TIMING CHAIN COVERS
- ★ KITS COME COMPLETE WITH LOCKING PLATE, OFFSET CAM BUSHINGS, ROLLER CAM BUTTON, & BRONZE THRUST BEARING

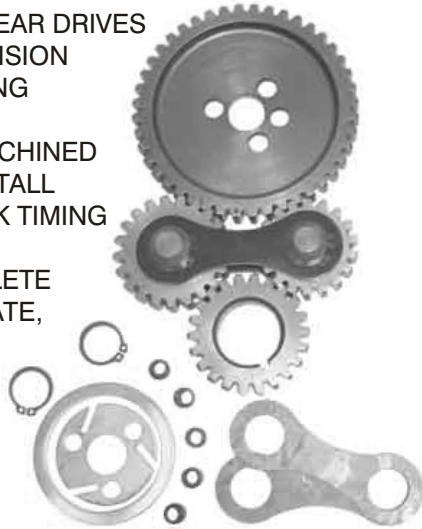

DESCRIPTION	PART #
SBC GEAR DRIVE	PCE 2151
BBC GEAR DRIVE	PCE 2152
SB FORD GEAR DRIVE	PCE 2153
FORD 351C GEAR DRIVE	PCE 2154
FORD 460 GEAR DRIVE	PCE 2155
CHRYSLER 440 GEAR DRIVE	PCE 2158
PONTIAC 455 GEAR DRIVE	PCE 2157
HOLDEN 253/308 GEAR DRIVE	PCE 2156
VOLKSWAGEN CAM GEARS	PCE 1399

# STEEL TIMING CHAIN COVER

- ★ FITS SMALL BLOCK CHEVY'S
- ★ GOLD PLATED STEEL
- ★ FEATURES REINFORCED CAM BRACE

**PART #415-002**



# ALUMINUM TIMING CHAIN COVERS

- ★ STOUT DIE-CAST DESIGN
- ★ FEATURES THICK GASKET RAILS FOR RIGIDITY & OPTIMUM OIL SEALING
- ★ SHOW-POLISHED FINISH



DESCRIPTION	PART #
SBC ALUM COVER	PCE 3321
SBC ALUM COVER, REMOVABLE	PCE 3322
BBC ALUM COVER	PCE 3323
BBC ALUM COVER, REMOVABLE	PCE 3324
BBC GEN. 5 ALUM COVER	PCE 3325
BBC GEN. 6 ALUM COVER	PCE 3326
SB FORD ALUM COVER	PCE 3327
SB FORD ALUM COVER, REMOVABLE	PCE 3328
BB FORD ALUM COVER	PCE 3329

# TIMING BELT DRIVE KITS

- ★ BELT DRIVE KITS REPRESENT THE ULTIMATE IN CAM TIMING, PROVIDING COMPETITION ENGINE BUILDERS WITH THE MOST ACCURATE VALVE TRAIN COMPONENTS AVAILABLE
- ★ BELT DRIVES REQUIRE LESS POWER TO OPERATE & ARE PROVEN TO BE MORE DURABLE THAN EITHER GEAR OR CHAIN DRIVES

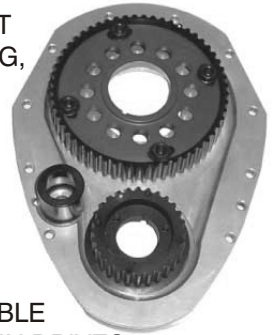

DESCRIPTION	PART #
SBC TIMING BELT DRIVE KIT	PCE 2231
BBC TIMING BELT DRIVE KIT	PCE 2232
FORD TIMING 302W BELT DRIVE KIT	PCE 2233
FORD TIMING 460 BELT DRIVE KIT	PCE 2234

# TIMING MARK INDICATORS

- ★ EASY-TO-READ
- ★ BOLT-ON
- ★ CHROME PLATED



DESCRIPTION	PART #
TIMING MARK INDICATOR, BOLT-ON, 7"	415-057
TIMING MARK INDICATOR, BOLT-ON, 8"	415-058

# SMALL BLOCK CHEVY TIMING COVER BOLT SET

- ★ 1/4"-20 HEX HEAD TIMING COVER BOLTS MANUFACTURED OF PLATED GRADE 8 STEEL



- ★ INTEGRAL SERRATED WASHER FACE INSURES POSITIVE LOCKING AGAINST THE TIMING COVER

**PART #496-0109**

- ★ FITS SBC, BBC, & 90 DEGREE V6 CHEVY
- ★ SOLD IN SETS OF 10

# SMALL BLOCK CHEVY BALANCER/DAMPER BOLT

- ★ FITS SBC; 7/16"-20
- ★ 12-POINT HEAD ACCEPTS 5/8" SOCKET TO PROVIDE POSITIVE GRIP FOR REMOVAL/ INSTALLATION WITHOUT STRIPPING



**PART #496-0232**

- ★ LARGE, 2" DIAMETER WASHER IS 1/4" THICK & MACHINED FLAT TO SPREAD THE FASTENING LOAD OVER A LARGER SURFACE AREA
- ★ BLACK OXIDE FINISH

Place your order at (479) 646-6988, Fax to (479) 646-5939, or visit [www.southwestspeed.com](http://www.southwestspeed.com)



## RACING FLUID DAMPERS

- ★ DAMPER HOUSINGS ARE MANUFACTURED FROM FORGED K1045 LOW CARBON STEEL & FILLED WITH HIGH VISCOSITY SILICONE FLUID
- ★ A NYLON RING & THE NYLON POSITIVE GUIDES ALLOW THE STEEL INERTIA RING TO ROTATE FREELY INSIDE THE HOUSING
- ★ THE STEEL INERTIA RING ROTATES HARMONICALLY WITH THE ENGINE & ABSORBS THE TORSION VIBRATION FROM THE ROTATING ASSEMBLY AT ANY FREQUENCY & RPM
- ★ THUS, IT EXTENDS THE LIFE OF THE CRANKSHAFT & BEARING AND ALLOWS THE ENGINE TO PRODUCE MORE POWER & TORQUE
- ★ ALL DAMPERS ARE EXPLOSION PROOF TESTED UP TO 12,500 RPM

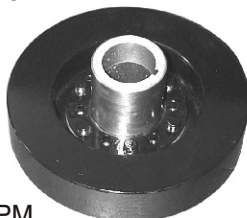

DESCRIPTION	PART #
CHEVY 262-350	PCE 4151
CHEVY 400	PCE 4152
CHEVY 400, CHROME	PCE 4152C
CHEVY 396-427	PCE 4153
CHEVY 454-504	PCE 4154
SB FORD 289-400, BLACK, 28 OZ.	PCE 4155
SB FORD 289-400, CHROME, 28 OZ.	PCE 4155C
SB FORD HO 289-400, BLACK, 50 OZ.	PCE 4156
SB FORD HO 289-400, CHROME, 50 OZ.	PCE 4156C
BB FORD 429-460	PCE 4158
SB CHRYSLER 318-360	PCE 4159
SB CHRYSLER 383-440	PCE 4160
PONTIAC 326-455	PCE 4161
OLDSMOBILE 305-455	PCE 4162

## BALANCER PULLER KIT

- ★ INCLUDES 2 & 3 WAY YOKE, 5" PRESSURE SCREW (3/4"-16), SMALL & LARGE CENTERING ADAPTERS, FLAT SHAFT ADAPTER, & OVER 35 BOLTS & WASHERS FOR REMOVING ALMOST ANY BALANCER

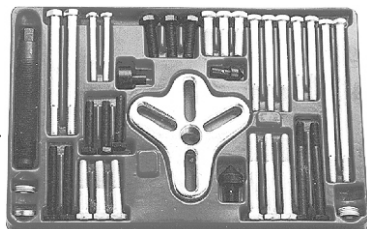

**PART #705-015**

## BALANCER COUNTER WEIGHT PLATE

- ★ PLATED FOR LONG LIFE
- ★ BOLTS TO 400 CHEVY CRANK
- ★ ELIMINATES THE NEED FOR BALANCED FLYWHEEL
- ★ MODIFICATION REQUIRED IF USED WITH RING GEAR UNDER 10 1/2" DIAMETER

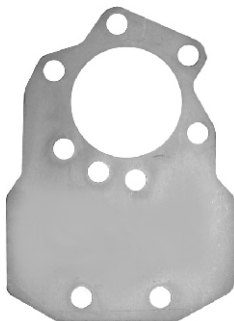

**PART #650-020**

## RACING STEEL ELASTIC DAMPERS

- ★ K1045 LOW CARBON STEEL ELASTIC DAMPERS
- ★ THE "S" SHAPE GAP BETWEEN THE INNER & OUTER RING IS PRESS INSERTED WITH SULFATED ELASTIC RUBBER TO ENSURE THE DAMPER WON'T DISINTEGRATE UNDER ANY CIRCUMSTANCE
- ★ ALL DAMPERS ARE TESTED TO 12,500 RPM FOR EXPLOSION PROOF RACING APPLICATIONS & TESTED TO WITHSTAND 15 TONS PRESS-FORCE WITHOUT SEPARATION OR DETERIORATION

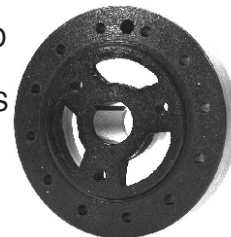

DESCRIPTION	PART #
CHEVY 262-350	PCE 4166
CHEVY 305-350, EARLY, PRE-1986	PCE 4167
CHEVY 305-350, LATE, 1986-UP	PCE 4168
CHEVY 400, 6.25"	PCE 4169
CHEVY 400, 8.00"	PCE 4169-8
CHEVY 427	PCE 4170
CHEVY 454	PCE 4171
SB FORD	PCE 4173
FORD 302 WINDSOR HO	PCE 4172
FORD 302 WINDSOR SPHO	PCE 4174
FORD 460	PCE 4175
SB CHRYSLER	PCE 4176
BB CHRYSLER	PCE 4177
PONTIAC	PCE 4178
OLDSMOBILE	PCE 4179

## STREET STEEL ELASTIC DAMPERS

- ★ MANUFACTURED FROM DUCTILE IRON MATERIAL
- ★ THE SUPERIOR STRENGTH & ELONGATION CHARACTERS OF DUCTILE IRON INNER & OUTER RINGS HAS THE BEST RELIABILITY & USAGE LIFE FOR STREET PERFORMANCE
- ★ SULFATED & HEATED ELASTIC RUBBER IS BONDED IN BETWEEN INNER & OUTER RING PROVIDING THE BEST STRENGTH & THE SAFEST STREET DAMPER IN THE INDUSTRY
- ★ ALL DAMPERS ARE TESTED TO WITHSTAND 15 TONS PRESS-FORCE WITHOUT SEPARATION OR DETERIORATION

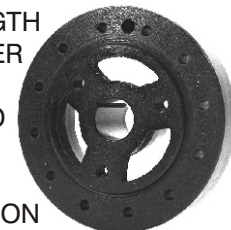

DESCRIPTION	PART #
CHEVY 262-350, 8.00"	PCE 4181
CHEVY 305-350	PCE 4182
CHEVY 400	PCE 4183
CHEVY 396-427	PCE 4184
CHEVY 454-504	PCE 4185
FORD 289-400	PCE 4186
FORD HO 289-400	PCE 4187
BB FORD 390	PCE 4188
BB FORD 429-460	PCE 4189

Place your order at (479) 646-6988, Fax to (479) 646-5939, or visit [www.southwestspeed.com](http://www.southwestspeed.com)

## BILLET STEEL MAIN CAPS

- ★ MANUFACTURED FROM 1025 LOW CARBON STEEL
- ★ MAIN CAPS IMPROVE RELIABILITY IN HIGHLY STRESSED ENGINES BY TYING THE CAP TO THE STRONGEST PART OF THE BLOCK
- ★ THEY ALSO REDUCE DISTORTION OF MAIN BEARING BORES BY INCREASING THE CAP'S RESISTANCE TO CLOSING UNDER HIGH LOADS

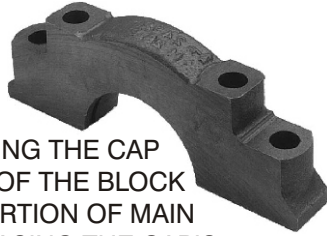

DESCRIPTION	PART #
CHEVY 305/350 4 BOLT OEM REPLACE.	PCE 4201
CHEVY 305/350 4 BOLT SPLAYED CAPS	PCE 4202
CHEVY 305/350 4 BOLT STRAIGHT CAPS	PCE 4203
CHEVY 400 4 BOLT SPLAYED CAPS	PCE 4204
CHEVY 454/502 4 BOLT OEM REPLACE.	PCE 4205
CHEVY 454/505 4 BOLT STRAIGHT CAPS	PCE 4206
FORD 302W 2 BOLT OEM REPLACEMENT	PCE 4207
FORD 302W 4 BOLT SPLAYED CAPS	PCE 4208
FORD 351W 4 BOLT SPLAYED CAPS	PCE 4209
FORD 351W 4 BOLT STRAIGHT CAPS	PCE 4210
FORD 351C 4 BOLT MAIN CAPS	PCE 4214
FORD 460 4 BOLT SPLAYED CAPS	PCE 4211
MOPAR 440 2 BOLT OEM REPLACEMENT	PCE 4212
PONTIAC 421-455 4 BOLT SPLAYED CAPS	PCE 4213
HOLDEN 253/308 4 BOLT MAIN CAPS	PCE 4215

## BILLET STEEL MAIN GIRDLES

- ★ MACHINED FROM 1045 MEDIUM CARBON STEEL
- ★ DESIGNED TO REDUCE THE MAIN CAPS FROM WALKING IN HIGH HORSEPOWER APPLICATIONS
- ★ FLAT SURFACES ARE FINISHED WITH CNC MACHINING FOR ACCURACY & SMOOTHNESS
- ★ GIRDLES ARE ZINC ANODIZED FOR RUST RESISTANCE
- ★ EACH GIRDLE INCLUDES 5140 HIGH STRENGTH STUDS FOR HIGH TORQUE APPLICATIONS



DESCRIPTION	PART #
CHEVY 350 MAIN GIRDLE	PCE 4191
CHEVY 350 LS1 MAIN GIRDLE	PCE 4192
CHEVY 400 MAIN GIRDLE	PCE 4193
CHEVY 454 MAIN GIRDLE	PCE 4194
FORD 302 WINDSOR MAIN GIRDLE	PCE 4195
FORD 351 WINDSOR MAIN GIRDLE	PCE 4196
FORD 460 MAIN GIRDLE	PCE 4197

## MAIN BOLTS & WASHERS

- ★ MANUFACTURED FROM CHROMEMOLY STEEL FOR HIGH PERFORMANCE APPLICATIONS
- ★ BOLTS ARE HEAT-TREATED & BLACK OXIDIZED FOR STRENGTH OVER 150,000 PSI



DESCRIPTION	PART #
CHEVY 305/350 BOLTS & WASHERS	PCE 4221
CHEVY 454 BOLTS & WASHERS	PCE 4222
FORD 302 WINDSOR BOLTS & WASHERS	PCE 4223
FORD 351 WINDSOR BOLTS & WASHERS	PCE 4224
FORD 460 BOLTS & WASHERS	PCE 4225

## ENGINE OVERHAUL & REBUILD GASKET SETS

- ★ SETS ARE AVAILABLE TO REBUILD, AS WELL AS COMPLETELY OVERHAUL NUMEROUS ENGINES

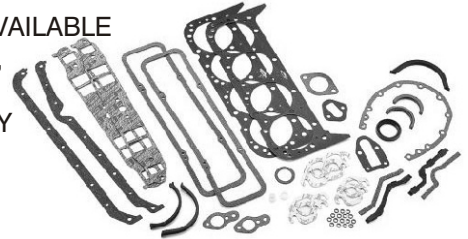

COMPLETE OVERHAUL SETS	PART #
SBC SET	PCE 2600-1000
BBC SET	PCE 2600-1009
SB FORD SET	PCE 2600-1125
FULL REBUILD SETS	PART #
SBC 327/350 SET	PCE 2600-327/350
BBC 454 SET	PCE 2600-454
SB FORD 289/302W SET	PCE 2600-289/302W
SB FORD 351W SET	PCE 2600-351W
FORD 351C SET	PCE 2600-351C

## HEAD GASKETS

- ★ MULTI-LAYERED STEEL GASKETS ARE COMPRISED OF MULTIPLE LAYERS OF STAINLESS STEEL
- ★ THE OUTER LAYERS OF THE GASKETS ARE EMBOSSED & COATED ON BOTH SIDES WITH RUBBER-BASED VITON

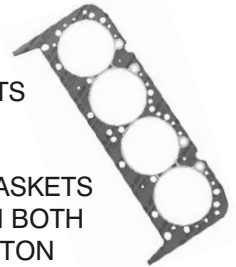

DESCRIPTION	PART #
SBC HEAD GASKET (EACH)	PCE 5210
BBC HEAD GASKET (EACH)	PCE 5211
CHEVY LS1 HEAD GASKET (EACH)	PCE 5213
SBF 289-351W HEAD GASKET (EACH)	PCE 5214
FORD 351C HEAD GASKET (EACH)	PCE 5212

## MAIN STUD KITS

- ★ MANUFACTURED FROM AIRCRAFT QUALITY 8740 HIGH TENSILE STRENGTH CHROMEMOLY STEEL
- ★ WITHSTANDS UP TO 190,000 PSI
- ★ KITS COME COMPLETE WITH 12 POINT HEX NUTS & WASHERS

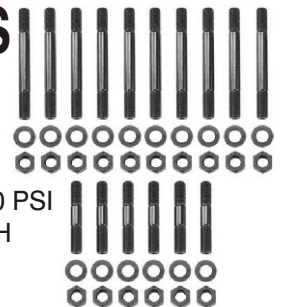

DESCRIPTION	PART #
SBC 2 BOLT STUD KIT	PCE 2421
SBC 4 BOLT STUD KIT	PCE 2422
BBC 2 BOLT STUD KIT	PCE 2423
BBC 4 BOLT STUD KIT	PCE 2424
FORD 250 2 BOLT STUD KIT	PCE 2425
FORD 302W 2 BOLT STUD KIT	PCE 2426
FORD 351W 2 BOLT STUD KIT	PCE 2427
FORD 351C 2 BOLT STUD KIT	PCE 2428
FORD 460 2 BOLT STUD KIT	PCE 2429
CHRYSLER 260 2 BOLT STUD KIT	PCE 2430
CHRYSLER 318 2 BOLT STUD KIT	PCE 2431
CHRYSLER 440 2 BOLT STUD KIT	PCE 2432
HOLDEN 186/202 2 BOLT STUD KIT	PCE 2433
HOLDEN 253/308 2 BOLT STUD KIT	PCE 2434
HOLDEN 253/308 4 BOLT STUD KIT	PCE 2435

Place your order at (479) 646-6988, Fax to (479) 646-5939, or visit [www.southwestspeed.com](http://www.southwestspeed.com)

# 4340 FORGED STEEL CRANKSHAFTS

- ★ PREMIUM STEEL CRANKSHAFTS HAVE EXCEPTIONAL STRENGTH & UNSURPASSED QUALITY
- ★ FORGINGS RUN THROUGH A MULTI-STEP HEAT-TREATING PROCESS TO PROVIDE ADDITIONAL CORE STRENGTH
- ★ TENSILE STRENGTH OF 145,000 PSI
- ★ ROD & MAIN JOURNAL SURFACES ARE HARDENED FOR SUPERIOR WEAR RESISTANCE
- ★ 100% X-RAYED, STRESS RELIEVED, & SHOT-PEENED
- ★ FEATURES CROSS-DRILLED & CHAMFERED OIL HOLES FOR IMPROVED OILING
- ★ "A" = MAIN JOURNAL
- ★ "B" = ROD JOURNAL
- ★ "C" = STROKE
- ★ "D" = ROD LENGTH
- ★ "LW" MEANS LIGHTER WEIGHT



DESCRIPTION	"A"	"B"	"C"	"D"	PART #
CHEVY 350	2.449"	2.1"	3.480"	OEM	PCE 4001
CHEVY 350, LW	2.449"	2.1"	3.480"	OEM	PCE 4001LW
CHEVY 350	2.449"	2.1"	3.500"	OEM	PCE 4002
CHEVY 350	2.449"	2.1"	3.562"	OEM	PCE 4003
CHEVY 350	2.449"	2.1"	3.750"	5.7"	PCE 4004-5.7
CHEVY 350	2.449"	2.1"	3.750"	6"	PCE 4004
CHEVY 350, LW	2.449"	2.1"	3.750"	6"	PCE 4004LW
CHEVY 350	2.449"	2.1"	3.875"	6"	PCE 4005
CHEVY 350	2.449"	2.1"	4.000"	6"	PCE 4011
CHEVY 350,86-UP, 1PC.	2.449"	2.1"	3.480"	OEM	PCE 4012
CHEVY 350,86-UP, 1PC.	2.449"	2.1"	3.750"	OEM	PCE 4013
CHEVY 350,86-UP, 1PC.	2.449"	2.1"	3.750"	OEM	PCE 4013LW
CHEVY 400	2.649"	2.1"	3.750"	5.7"	PCE 4014
CHEVY 400	2.649"	2.1"	4.000"	5.7"	PCE 4015
CHEVY 400	2.649"	2.1"	4.250"	5.7"	PCE 4016
CHEVY 454	2.749"	2.2"	3.766"	OEM	PCE 4017
CHEVY 454	2.749"	2.2"	4.000"	OEM	PCE 4018
CHEVY 454	2.749"	2.2"	4.250"	OEM	PCE 4019
CHEVY 454	2.749"	2.2"	4.375"	OEM	PCE 4020
CHEVY 454	2.749"	2.2"	4.500"	OEM	PCE 4021
CHEVY 454	2.749"	2.2"	4.750"	OEM	PCE 4022
CHEVY 502	2.749"	2.2"	4.000"	OEM	PCE 4023
CHEVY 502	2.749"	2.2"	4.250"	OEM	PCE 4024
CHEVY 502	2.749"	2.2"	4.500"	OEM	PCE 4025
FORD 302W EFI HO	2.2486"	2.1232"	3.000"	OEM	PCE 4026
FORD 302W EFI HO	2.2486"	2.1232"	3.250"	OEM	PCE 4027
FORD 302W EFI HO	2.2486"	2.1000"	3.250"	OEM	PCE 4028
FORD 302W EFI HO	2.2486"	2.1232"	3.400"	OEM	PCE 4029
FORD 302W EFI HO	2.2486"	2.1000"	3.400"	OEM	PCE 4030
FORD 302W EFI HO	2.2486"	2.1000"	3.470"	OEM	PCE 4031
FORD 351W HO	3.000"	2.3100"	3.500"	OEM	PCE 4032
FORD 351W HO	3.000"	2.1000"	3.750"	OEM	PCE 4033
FORD 351W HO	3.000"	2.1000"	4.000"	OEM	PCE 4034
FORD 351W HO	3.000"	2.1000"	4.100"	OEM	PCE 4034-4100
FORD 351W HO	3.000"	2.1000"	4.170"	OEM	PCE 4034-4170
FORD 351W HO	3.000"	2.1000"	4.250"	OEM	PCE 4034-4250
FORD 460	3.649"	2.5000"	4.500"	OEM	PCE 4050
DODGE 440	2.750"	2.3750"	STOCK	OEM	PCE 4035
DODGE 440	2.750"	2.3750"	4.125"	OEM	PCE 4036
DODGE 440	2.750"	2.3750"	4.150"	OEM	PCE 4036-4150
DODGE 440	2.750"	2.3750"	4.250"	OEM	PCE 4037

# CRANKSHAFT FLANGE WEIGHT

- ★ WELDS TO CRANKSHAFT TO EXTERNALLY BALANCE ENGINE ASSEMBLIES



PART #401-142

# CRANKSHAFTS CONVERSION SEAL ADAPTERS

- ★ MADE FROM 2024 T3511 ALUMINUM
- ★ ALLOWS LATE MODEL CRANKSHAFTS TO BE USED IN EARLY MODEL BLOCKS & VICE VERSA



DESCRIPTION	PART #
CONVERTS 1968-85 CRANK TO 1986-UP CHEVY BLOCK	401-145
CONVERTS 1986-UP CRANK TO 1968-85 CHEVY BLOCK	401-146

# CRANKSHAFT ROTATION TOOL

- ★ BOLTS TO THE BACK OF THE CRANKSHAFT FLANGE TO ROTATE CHEVY ENGINES
- ★ ACCEPTS 1/2" SQUARE DRIVE
- ★ STRONG ALUMINUM CONSTRUCTION

PART #705-040



# ENGINE CRADLE

- ★ HEAVY DUTY STEEL CONSTRUCTION
- ★ 1000LB CAPACITY
- ★ 3" SWIVEL CASTERS
- ★ POWDER COATED FINISH
- ★ ENGINE BOLTS INCLUDED



PART #410-805

Place your order at (479) 646-6988, Fax to (479) 646-5939, or visit [www.southwestspeed.com](http://www.southwestspeed.com)



# 5140 FORGED STEEL CRANKSHAFTS

- ★ EXCEPTIONAL STRENGTH & UNSURPASSED QUALITY
- ★ FORGINGS RUN THROUGH A MULTI-STEP HEAT-TREATING PROCESS TO PROVIDE ADDITIONAL CORE STRENGTH
- ★ TENSILE STRENGTH OF 115,000 PSI
- ★ FEATURES INCLUDE STRAIGHT SHOT & CHAMFERED OIL HOLES, NITRIDE HARDENED FOR SUPERIOR WEAR RESISTANCE, LIGHTNING HOLES IN ALL ROD THROWS, LARGE RADIUS ON ALL JOURNALS, PRECISION-GROUND & SHOT-PEENED



DESCRIPTION	"A"	"B"	"C"	"D"	PART #
CHEVY 350	2.449"	2.1"	3.480"	OEM	PCE 4051
CHEVY 350	2.449"	2.1"	3.500"	OEM	PCE 4052
CHEVY 350	2.449"	2.1"	3.562"	OEM	PCE 4053
CHEVY 350	2.449"	2.1"	3.750"	5.7"	PCE 4054-5.7
CHEVY 350	2.449"	2.1"	3.750"	6"	PCE 4054
CHEVY 350	2.449"	2.1"	4.000"	6"	PCE 4054-4000
CHEVY 400	2.649"	2.1"	3.750"	5.7"	PCE 4055
CHEVY 400	2.649"	2.1"	4.000"	5.7"	PCE 4056
CHEVY 454	2.749"	2.2"	4.000"	OEM	PCE 4057
CHEVY 454	2.749"	2.2"	4.250"	OEM	PCE 4058
FORD 302W EFI HO	2.2486"	2.1232"	3.000"	OEM	PCE 4059
FORD 302W EFI HO	2.2486"	2.1232"	3.250"	OEM	PCE 4060
FORD 302W EFI HO	2.2486"	2.1232"	3.400"	OEM	PCE 4061
FORD 302W EFI HO	2.2486"	2.1000"	3.400"	OEM	PCE 4062

- ★ "A" = MAIN JOURNAL
- ★ "B" = ROD JOURNAL
- ★ "C" = STROKE
- ★ "D" = ROD LENGTH



# OEM IRON CRANKSHAFTS

- ★ 1053 IRON ALLOY CRANKSHAFTS ARE DESIGNED TO REPLACE STOCK SHAFTS THAT HAVE SEEN BETTER DAYS
- ★ PERFECT REPLACEMENTS FOR MILDLY BUILT STREET ENGINES
- ★ FEATURING PRECISION-GROUND, MICRO-POLISHING, & STANDARD SIZED BEARINGS
- ★ TENSILE STRENGTH OF 100,000 PSI
- ★ CRANKSHAFTS ARE BALANCED & READY TO INSTALL OUT OF THE BOX WITH NO MORE HASSLES FROM POOR QUALITY CORES

DESCRIPTION	"A"	"B"	"C"	"D"	PART #
CHEVY 350	2.449"	2.1"	STOCK	OEM	PCE 4076
CHEVY 350	2.449"	2.1"	3.480"	OEM	PCE 4079
CHEVY 350, EXT. BAL.	2.449"	2.1"	3.750"	OEM	PCE 4077
CHEVY 350,86-UP, 1PC.	2.449"	2.1"	STOCK	OEM	PCE 4080
CHEVY 350, 1PC., E.B.	2.449"	2.1"	3.750"	OEM	PCE 4078
CHEVY 400	2.649"	2.1"	STOCK	OEM	PCE 4081
CHEVY 454	2.749"	2.2"	4.000"	OEM	PCE 4082
CHEVY 454	2.749"	2.2"	4.250"	OEM	PCE 4083
CHEVY 454/502, 1PC.	2.749"	2.2"	STOCK	OEM	PCE 4084
FORD 302W EFI HO	2.2486"	2.1232"	3.000"	OEM	PCE 4085
FORD 302W EFI HO	2.2486"	2.1232"	3.250"	OEM	PCE 4086
FORD 302W EFI HO	2.2486"	2.1232"	3.400"	OEM	PCE 4087
FORD 302W EFI HO	2.2486"	2.1000"	3.400"	OEM	PCE 4087-2100
FORD 302W EFI HO	2.2486"	2.1232"	3.470"	OEM	PCE 4087-3470
FORD 351W HO	3.000"	2.3100"	STOCK	OEM	PCE 4088
FORD 460	3.649"	2.5000"	STOCK	OEM	PCE 4089
FORD 460	3.649"	2.5000"	4.140"	OEM	PCE 4096
DODGE 426	2.750"	2.3750"	STOCK	OEM	PCE 4090
DODGE 426	2.750"	2.3750"	4.125"	OEM	PCE 4091
DODGE 440	2.750"	2.3745"	STOCK	OEM	PCE 4092
DODGE 440	2.750"	2.3745"	4.125"	OEM	PCE 4093
PONTIAC 400	3.000"	2.2490"	4.210"	OEM	PCE 4094
PONTIAC 455	3.250"	2.2490"	STOCK	OEM	PCE 4095
CHEVY LS1			4.000"	OEM	PCE 4099
CHEVY LS1			4.150"	OEM	PCE 4100

- ★ "A" = MAIN JOURNAL
- ★ "B" = ROD JOURNAL
- ★ "C" = STROKE
- ★ "D" = ROD LENGTH



Place your order at (479) 646-6988, Fax to (479) 646-5939, or visit [www.southwestspeed.com](http://www.southwestspeed.com)

## 4340 "H" BEAM STREET/STRIP CONNECTING RODS

- ★ MANUFACTURED FROM AIRCRAFT QUALITY 4340 CHROMEMOLY STEEL; RODS ARE X-RAYED & ULTRASONICALLY TESTED WITH ALL SURFACES SHOT-PEENED & STRESS-RELIEVED
- ★ PERFECT FOR SMALL BLOCK ENGINES PRODUCING 700+ HP & BIG BLOCK ENGINES PRODUCING 800+ HP
- ★ BRASS BUSHING DESIGN
- ★ SOLD IN SETS OF 8



"A"=LENGTH  
"B"=CRANKSHAFT JOURNAL  
"C"=PISTON PIN  
"LW" MEANS LIGHTER WEIGHT

DESCRIPTION	"A"	"B"	"C"	PART #
SBC	5.700"	2.00"	0.927"	PCE 4111
SBC	5.700"	2.10"	0.927"	PCE 4112
SBC, LW	5.700"	2.10"	0.927"	PCE 4112LW
SBC	6.000"	2.00"	0.927"	PCE 4113
SBC	6.000"	2.10"	0.927"	PCE 4114
SBC, LW	6.000"	2.10"	0.927"	PCE 4114LW
SBC	6.125"	2.10"	0.927"	PCE 4115
SBC	6.200"	2.10"	0.927"	PCE 4116
SBC	6.250"	2.10"	0.927"	PCE 4117
BBC	6.135"	2.22"	0.990"	PCE 4118
BBC	6.335"	2.22"	0.990"	PCE 4110-6335
BBC	6.385"	2.22"	0.990"	PCE 4119
BBC	6.435"	2.22"	0.990"	PCE 4110-6435
BBC	6.535"	2.22"	0.990"	PCE 4120
BBC	6.700"	2.22"	0.990"	PCE 4121
BBC	6.800"	2.22"	0.990"	PCE 4122
SB FORD	5.400"	2.100"	0.927"	PCE 4123
SB FORD	5.400"	2.123"	0.927"	PCE 4124
SB FORD	5.400"	2.100"	0.912"	PCE 4125
SB FORD	5.400"	2.123"	0.912"	PCE 4126
FORD 351W	5.956"	2.310"	0.912"	PCE 4127

## 4340 "I" BEAM RACING RODS

- ★ MANUFACTURED FROM AIRCRAFT QUALITY 4340 CHROMEMOLY STEEL & DESIGNED TO BE THE MOST RELIABLE RODS IN THE RACING INDUSTRY
- ★ X-RAYED & ULTRASONICALLY TESTED WITH ALL SURFACES SHOT-PEENED & STRESS-RELIEVED
- ★ PERFECT FOR ENGINES PRODUCING 1000+ HP
- ★ BRASS BUSHING DESIGN
- ★ SOLD IN SETS OF 8



"A"=LENGTH  
"B"=CRANKSHAFT JOURNAL  
"C"=PISTON PIN

DESCRIPTION	"A"	"B"	"C"	PART #
SBC	5.700"	2.10"	0.927"	PCE 4131
SBC	6.000"	2.10"	0.927"	PCE 4132
SBC	6.125"	2.10"	0.927"	PCE 4133
BBC	6.135"	2.22"	0.990"	PCE 4134
BBC	6.385"	2.22"	0.990"	PCE 4135
BBC	6.535"	2.22"	0.990"	PCE 4136
BBC	6.800"	2.22"	0.990"	PCE 4137
BBC	7.100"	2.22"	0.990"	PCE 4138
SB FORD	5.400"	2.10"	0.927"	PCE 4139
SB FORD	6.200"	2.10"	0.927"	PCE 4140

## 5140 "I" BEAM STREET CONNECTING RODS

- ★ MANUFACTURED FROM HIGH-QUALITY 5140 CHROMEMOLY STEEL
- ★ PRESS-FIT & BRASS BUSHING RODS AVAILABLE
- ★ X-RAYED & ULTRASONICALLY TESTED WITH ALL SURFACES SHOT-PEENED & STRESS-RELIEVED
- ★ PERFECT FOR ENGINES PRODUCING 500+ HP
- ★ SOLD IN SETS OF 8



"A"=LENGTH  
"B"=CRANKSHAFT JOURNAL  
"C"=PISTON PIN

DESCRIPTION	"A"	"B"	"C"	PART #
SBC, PRESS	5.700"	2.10"	0.927"	PCE 4101
SBC, BUSHING	5.700"	2.10"	0.927"	PCE 4102
SBC, PRESS	6.000"	2.10"	0.927"	PCE 4103
SBC, BUSHING	6.000"	2.10"	0.927"	PCE 4104
SBC, LS1	6.098"	2.225"	.9447"	PCE 4105
BBC	6.135"	2.22"	0.990"	PCE 4107
SBF, BUSHING	5.400"	2.123"	0.912"	PCE 4106

## HYPEREUTECTIC PISTONS

- ★ HYPEREUTECTIC PISTONS WITH ANTI-FRICTION SKIRT COATING ARE IDEAL FOR OVAL TRACK RACING, BRACKET RACING, & STREET USE
- ★ BY COMBINING THE HYPEREUTECTIC ALLOY WITH THE PERMANENT MOLD PROCESS, THE PISTON IS STRONG, LIGHTWEIGHT, & THERMALLY-EFFICIENT
- ★ HIGHLY RESISTANT TO SCUFFING & WEAR AND THEY RUN TIGHTER PISTON-TO-WALL CLEARANCES, WHICH IMPROVES RING SEAL & LONGEVITY



DESCRIPTION	PART #
5.7" ROD, 4" +0.020", 383 HYPER.	PCE 4701
5.7" ROD, 4" +0.030", 383 HYPER.	PCE 4702
5.7" ROD, 4" +0.040", 383 HYPER.	PCE 4703
5.7" ROD, 4" +0.060", 383 HYPER.	PCE 4704

## FORGED FLAT TOP PISTONS

- ★ MADE FROM 4032 ALUMINUM ALLOY FOR QUIETER SPECTRUM & REDUCED PISTON-TO-WALL CLEAR.
- ★ UP TO 20% LIGHTER THAN TRADITIONAL FORGED PISTONS
- ★ ELIMINATES HARMFUL STRESS CONCENTRATIONS & PROVIDES SUPERIOR STRENGTH
- ★ SPECIFICALLY DESIGNED FOR NATURALLY ASPIRATED & MODERATE NITROUS APPLICATIONS



DESCRIPTION	PART #
5.7" ROD, 4" +0.020", 383 FLAT TOP	PCE 4710
5.7" ROD, 4" +0.030", 383 FLAT TOP	PCE 4711
5.7" ROD, 4" +0.040", 383 FLAT TOP	PCE 4713
5.7" ROD, 4" +0.060", 383 FLAT TOP	PCE 4714
6.0" ROD, 4" STD., 383/302/347 FLAT TOP	PCE 4720
6.0" ROD, 4" +0.020", 383/302/347 F. TOP	PCE 4721
6.0" ROD, 4" +0.030", 383/302/347 F. TOP	PCE 4722
6.0" ROD, 4" +0.040", 383/302/347 F. TOP	PCE 4723
6.0" ROD, 4" +0.060", 383/302/347 F. TOP	PCE 4724

Place your order at (479) 646-6988, Fax to (479) 646-5939, or visit [www.southwestspeed.com](http://www.southwestspeed.com)

# HIGH PERFORMANCE PISTON RINGS

★ DESIGNED TO STAND UP TO THE RIGORS OF RACING & HIGH PERFORMANCE STREET USE, WHILE PROVIDING A LONG LASTING LIFE

★ THEY FEATURE: \*PLASMA-MOLY COATED, BARREL-SHAPED, DUCTILE IRON TOP RINGS THAT SEAT AGAINST BLOW-BY WHEN THE PISTON ROCKS IN ITS BORE,

\*TAPERED SECONDARY RINGS THAT SEAL AGAINST THE OIL CONTROL RING'S UPPER SURFACE FOR EXCELLENT OIL CONTROL, &

\*3-PIECE OIL RINGS WITH STAINLESS STEEL EXPANDERS THAT PROVIDE ACCURATE TENSION WITHOUT THE LOSS OF ANY HORSEPOWER

★ "A" = BORE

★ "B" = TOP RING THICKNESS

★ "C" = MIDDLE RING THICKNESS

★ "D" = OIL RING THICKNESS



"A"	"B"	"C"	"D"	PART #
<b>MOLY REPLACEMENT HIGH PERFORMANCE RINGS</b>				
4" STD.	5/64"	5/64"	3/16"	PCE 4501
4" +.020"	5/64"	5/64"	3/16"	PCE 4502
4" +.030"	5/64"	5/64"	3/16"	PCE 4503
4" +.040"	5/64"	5/64"	3/16"	PCE 4504
4" +.060"	5/64"	5/64"	3/16"	PCE 4505
4.125" STD.	5/64"	5/64"	3/16"	PCE 4506
4.125" +.030"	5/64"	5/64"	3/16"	PCE 4507
4.125" +.040"	5/64"	5/64"	3/16"	PCE 4508
4.125" +.060"	5/64"	5/64"	3/16"	PCE 4509
<b>NON-FILE BACK MOLY HIGH PERFORMANCE RINGS</b>				
4" STD.	1/16"	1/16"	1/8"	PCE 4526
4" +.020"	1/16"	1/16"	1/8"	PCE 4527
4" +.030"	1/16"	1/16"	1/8"	PCE 4528
4" +.040"	1/16"	1/16"	1/8"	PCE 4529
4" +.060"	1/16"	1/16"	1/8"	PCE 4530
4" STD.	1/16"	1/16"	3/16"	PCE 4531
4" +.020"	1/16"	1/16"	3/16"	PCE 4532
4" +.030"	1/16"	1/16"	3/16"	PCE 4533
4" +.040"	1/16"	1/16"	3/16"	PCE 4534
4" +.060"	1/16"	1/16"	3/16"	PCE 4535
4" STD.	1.5mm	1.5mm	3mm	PCE 4536
4" +.020"	1.5mm	1.5mm	3mm	PCE 4537
4" +.030"	1.5mm	1.5mm	3mm	PCE 4538
4" +.040"	1.5mm	1.5mm	3mm	PCE 4539
4" +.060"	1.5mm	1.5mm	3mm	PCE 4540
4.125" STD.	1/16"	1/16"	1/8"	PCE 4541
4.125" +.030"	1/16"	1/16"	1/8"	PCE 4542
4.125" +.040"	1/16"	1/16"	1/8"	PCE 4543
4.125" +.060"	1/16"	1/16"	1/8"	PCE 4544
4.125" STD.	1/16"	1/16"	3/16"	PCE 4545
4.125" +.030"	1/16"	1/16"	3/16"	PCE 4546
4.125" +.040"	1/16"	1/16"	3/16"	PCE 4547
4.125" +.060"	1/16"	1/16"	3/16"	PCE 4548
4.125" STD.	1.5mm	1.5mm	3mm	PCE 4549
4.125" +.030"	1.5mm	1.5mm	3mm	PCE 4550
4.125" +.040"	1.5mm	1.5mm	3mm	PCE 4551
4.125" +.060"	1.5mm	1.5mm	3mm	PCE 4552

"A"	"B"	"C"	"D"	PART #
<b>FILE BACK MOLY HIGH PERFORMANCE RINGS</b>				
4" STD.	1/16"	1/16"	1/8"	PCE 4576
4" +.020"	1/16"	1/16"	1/8"	PCE 4577
4" +.030"	1/16"	1/16"	1/8"	PCE 4578
4" +.040"	1/16"	1/16"	1/8"	PCE 4579
4" +.060"	1/16"	1/16"	1/8"	PCE 4580
4" STD.	1/16"	1/16"	3/16"	PCE 4581
4" +.020"	1/16"	1/16"	3/16"	PCE 4582
4" +.030"	1/16"	1/16"	3/16"	PCE 4583
4" +.040"	1/16"	1/16"	3/16"	PCE 4584
4" +.060"	1/16"	1/16"	3/16"	PCE 4585
4" STD.	1.5mm	1.5mm	3mm	PCE 4586
4" +.020"	1.5mm	1.5mm	3mm	PCE 4587
4" +.030"	1.5mm	1.5mm	3mm	PCE 4588
4" +.040"	1.5mm	1.5mm	3mm	PCE 4589
4" +.060"	1.5mm	1.5mm	3mm	PCE 4590
4.125" STD.	1/16"	1/16"	1/8"	PCE 4591
4.125" +.030"	1/16"	1/16"	1/8"	PCE 4592
4.125" +.040"	1/16"	1/16"	1/8"	PCE 4593
4.125" +.060"	1/16"	1/16"	1/8"	PCE 4594
4.125" STD.	1/16"	1/16"	3/16"	PCE 4595
4.125" +.030"	1/16"	1/16"	3/16"	PCE 4596
4.125" +.040"	1/16"	1/16"	3/16"	PCE 4597
4.125" +.060"	1/16"	1/16"	3/16"	PCE 4598
4.125" STD.	1.5mm	1.5mm	3mm	PCE 4599
4.125" +.030"	1.5mm	1.5mm	3mm	PCE 4600
4.125" +.040"	1.5mm	1.5mm	3mm	PCE 4601
4.1252+.060"	1.5mm	1.5mm	3mm	PCE 4602
<b>ZERO GAP MOLY HIGH PERFORMANCE RINGS</b>				
4" STD.	1/16"	1/16"	1/8"	PCE 4626
4" +.020"	1/16"	1/16"	1/8"	PCE 4627
4" +.030"	1/16"	1/16"	1/8"	PCE 4628
4" +.040"	1/16"	1/16"	1/8"	PCE 4629
4" +.060"	1/16"	1/16"	1/8"	PCE 4630
4" STD.	1/16"	1/16"	3/16"	PCE 4631
4" +.020"	1/16"	1/16"	3/16"	PCE 4632
4" +.030"	1/16"	1/16"	3/16"	PCE 4633
4" +.040"	1/16"	1/16"	3/16"	PCE 4634
4" +.060"	1/16"	1/16"	3/16"	PCE 4635
4" STD.	1.5mm	1.5mm	3mm	PCE 4636
4" +.020"	1.5mm	1.5mm	3mm	PCE 4637
4" +.030"	1.5mm	1.5mm	3mm	PCE 4638
4" +.040"	1.5mm	1.5mm	3mm	PCE 4639
4" +.060"	1.5mm	1.5mm	3mm	PCE 4640
4.125" STD.	1/16"	1/16"	1/8"	PCE 4641
4.125" +.030"	1/16"	1/16"	1/8"	PCE 4642
4.125" +.040"	1/16"	1/16"	1/8"	PCE 4643
4.125" +.060"	1/16"	1/16"	1/8"	PCE 4644
4.125" STD.	1/16"	1/16"	3/16"	PCE 4645
4.125" +.030"	1/16"	1/16"	3/16"	PCE 4646
4.125" +.040"	1/16"	1/16"	3/16"	PCE 4647
4.125" +.060"	1/16"	1/16"	3/16"	PCE 4648
4.125" STD.	1.5mm	1.5mm	3mm	PCE 4649
4.125" +.030"	1.5mm	1.5mm	3mm	PCE 4650
4.125" +.040"	1.5mm	1.5mm	3mm	PCE 4651
4.125" +.060"	1.5mm	1.5mm	3mm	PCE 4652

Place your order at (479) 646-6988, Fax to (479) 646-5939, or visit [www.southwestspeed.com](http://www.southwestspeed.com)



# ENGINE LIFT PLATE & INTAKE COVER

- ★ PLATED 1/4" STEEL
- ★ 2 BOLT PATTERNS
- ★ 3 LIFT POSITIONS FOR BALANCE

**PART #410-800**



# ENGINE LOAD LEVELER

- ★ SIMPLY CRANK THE HEAVY-DUTY THREADED SHAFT TO BALANCE ENGINES OR TRANSMISSIONS AT THE PROPER ANGLE
- ★ BALANCING HEAVY, AWKWARD LOADS CAN BE A ONE-MAN JOB WITH THIS UNIT



**PART #705-095**

# TOP DEAD CENTER LOCATOR

- ★ EASILY CHECKS TOP DEAD CENTER BY BOLTING DOWN ACROSS CYLINDER BORE WITH HEADS OFF
- ★ SOLD AS A COMPLETE KIT



**PART #705-010**

# ENGINE BLOCK PLUG KIT

- ★ 20 PIECE KIT FOR SMALL BLOCK CHEVY BLOCKS

**PART #400-100**



# K&W BLOCK SEALER

- ★ REPAIRS SMALL CRACKS IN ENGINE BLOCKS & HEADS, AND SEALS SMALL LEAKS IN THE COOLING SYSTEM
- ★ SOLD IN 16 OUNCE CANS

**PART #940-004**

# MOTOR OIL

- ★ MAG 1 MOTOR OIL MEETS THE NEEDS OF ALL RACING & EVERYDAY PASSENGER CAR APPLICATIONS
- ★ IT IS SPECIALLY FORMULATED TO EXCEED THE TOUGHEST U.S. STANDARDS FOR OUTSTANDING PROTECTION & PERFORMANCE



DESCRIPTION	PART #
MAG 1 - 10W30 MOTOR OIL, 1 QUART	940-038
MAG 1 - 30 "HEAVY-DUTY" OIL, 1 QT.	940-035
MAG 1 - 30 "HEAVY-DUTY" OIL, 1 GAL.	940-0352

# PRO-BLEND CTX-2 RACING FUEL ADDITIVE

- ★ PRO-BLEND CTX-2 UNDETECTABLE FUEL ADDITIVE CAN ADD UP TO 40 CONFIDENTIAL HORSEPOWER
- ★ PRODUCES STRONG MID-RANGE TORQUE
- ★ SOLD IN 1 GALLON CANS
- ★ DESIGNED TO PASS FUEL TESTS
- ★ AN ABSOLUTE MUST FOR QUALIFYING
- ★ FOR THE FUEL CHECKS, IT HAS NO EFFECT ON THE ELECTRIC METER AND FOR THE SPECIFIC GRAVITY, 1 GALLON OF CTX-2 IN 4 GALLONS OF RACING GAS INCREASES THE S.G. ABOUT .035, WHICH SHOULD KEEP IT UNDER THE LIMITS OF MOST SANCTIONS



**PART # PBM 1650**

# OCTANE BOOST

- ★ INCREASES MID-RANGE TORQUE
- ★ USE WITH GAS OR ALCOHOL
- ★ MIX 16 OZ. CAN WITH 10 GAL. FUEL
- ★ WILL NOT PASS FUEL CHECKS
- ★ SOLD IN 16 OUNCE CANS



**PART #PBM 1616**

# ENGINE RACING CONCENTRATE

- ★ THIS METAL TREATMENT MAKES ENGINES VIRTUALLY INDESTRUCTIBLE
- ★ SOLD IN 16 OUNCE CANS
- ★ REDUCES OIL TEMP. UP TO 60° AT THE CRANKSHAFT
- ★ ALLOWS ENGINE TO RUN MUCH LONGER W/O DAMAGE SHOULD OIL PRESSURE FAIL OR OIL STARVATION OCCUR
- ★ DRAMATICALLY EXTENDS VALVE SPRING LIFE



**PART # PBM 1600**

# ALCOHOL LUBE

- ★ ABSOLUTE FINEST FOR ALL ENGINES BURNING ALCOHOL (METHANOL)
- ★ ELIMINATES CHALKING, POWDERING, ETCHING, AND LINE CLOGGING
- ★ MIX 16 OUNCES WITH 50 GALLONS OF FUEL
- ★ SOLD IN 16 OUNCE CANS



**PART #PBM 8400**

# THROTTLE LINKAGES TUBULAR ALUMINUM

- ★ 5/16" STUD ON PEDAL END
- ★ 1/4" STUD ON CARBURETOR END
- ★ MEASURED CENTER-OF-ROD-END TO CENTER-OF-ROD-END



DESCRIPTION	PART #
ALUM. LINKAGE KIT, 19 1/2" CENTERS	301-218
ALUM. LINKAGE KIT, 22 1/2" CENTERS	301-219
ALUM. LINKAGE KIT, 25 1/2" CENTERS	301-220
ALUM. LINKAGE KIT, 28 1/2" CENTERS	301-221
ALUM. LINKAGE KIT, 31 1/2" CENTERS	301-222

Place your order at (479) 646-6988, Fax to (479) 646-5939, or visit [www.southwestspeed.com](http://www.southwestspeed.com)

# THROTTLE PEDALS

## ORIGINAL TUBULAR STEEL PEDALS

★AVAILABLE TO MOUNT TO THE FRONT FIREWALL OR THE SIDE FIREWALL (WITH EITHER A STRAIGHT OR A 15° ANGLED MOUNT)

★LIGHTWEIGHT STEEL CONSTRUCTION

★GIVES QUALITY, SMOOTH RESPONSE

★EASY TO INSTALL

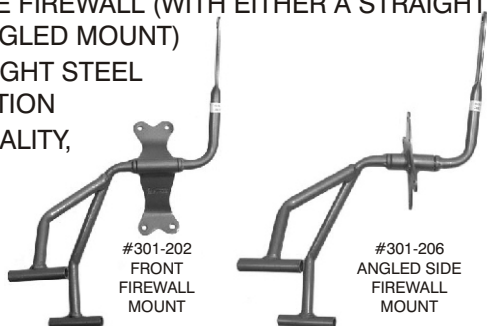

DESCRIPTION	PART #
FRONT FIREWALL MOUNT	301-202
STRAIGHT SIDE FIREWALL MOUNT	301-204
ANGLED SIDE FIREWALL MOUNT	301-206

## ALUMINUM, NEEDLE BEARING PEDALS

★FRONT FIREWALL MOUNT AND STRAIGHT & 15° ANGLED SIDE FIREWALL MOUNTS AVAILABLE

★SPLINED PIVOT SHAFT SUPPORTED BY DUAL NEEDLE BEARINGS & A KNURLED ALUMINUM ROLLER FOOT PEDAL ENSURE THAT YOU WILL HAVE THE SMOOTHEST OPERATING PEDAL IN THE INDUSTRY

★BOTH THE PEDAL & THE THROTTLE ARM CAN BE INDEXED TO SUIT YOUR SPECIFIC APPLICATION

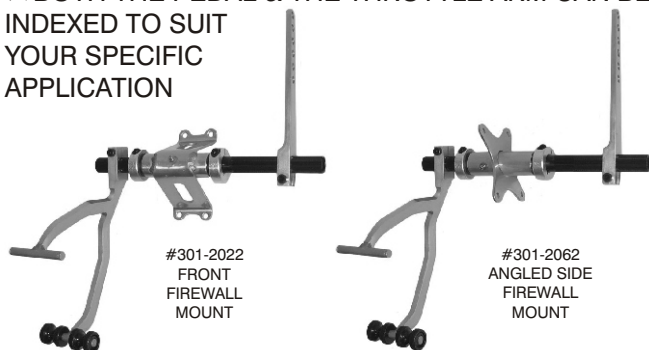

DESCRIPTION	PART #
FRONT FIREWALL MOUNT, BEARING	301-2022
STRAIGHT SIDE FIREWALL MT, BEARING	301-2042
ANGLED SIDE FIREWALL MT, BEARING	301-2062

## THROTTLE BYPASSES

★LINKAGE CONTROLLED BYPASS WITH PLATE

★POSITIVE RESPONSE

★RETURNS UNUSED FUEL TO FUEL CELL

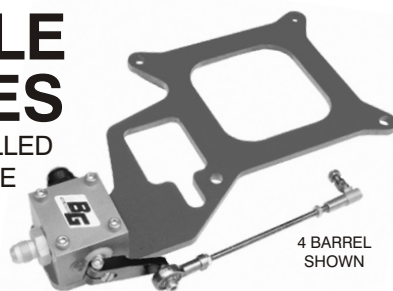

DESCRIPTION	PART #
2 BBL THROTTLE BYPASS	BGF 171022
4 BBL THROTTLE BYPASS	BGF 171024

## THROTTLE STOPS

★LIGHTWEIGHT ALUMINUM

★PREVENTS BROKEN THROTTLE ARMS

★2 STYLES AVAILABLE



DESCRIPTION	PART #
THROTTLE STOP KIT, FITS HOLLEY	410-920
THROTTLE STOP KIT, FITS DEMON*	410-921

\*WILL NOT FIT VACUUM SECONDARY DEMON CARBURETORS

## LINKAGE BUSHINGS

★ALUMINUM CONSTRUCTION

★1/4" BORE

★FITS MOST CARBURETORS

★SOLD IN PAIRS



PART #410-996

## THROTTLE RETURN KIT



★BOLTS TO CARBURETOR

★POSITIVE RESPONSE

★INCLUDES 2 DIFFERENT SPRING TENSIONS

PART #410-995

## THROTTLE RETURN SPRING BRACKET

★MOUNTS WITH 3/8" BOLT

★ACCEPTS MOST THROTTLE RETURN SPRINGS

PART #410-992



## ALUMINUM CARB COVERS

★LIGHTWEIGHT ALUMINUM WITH O-RING

★KEEPS CARBURETOR CLEAN & DRY

PART #411-320



## PLASTIC CARB COVERS

★PROTECTS THE ENGINE FROM DIRT AND DEBRIS

★INJECTION MOLDED



DESCRIPTION	PART #
PLASTIC, 4150 SERIES & DEMON	411-322
PLASTIC, 4150 SERIES & DEMON	BGF 110100
PLASTIC, 4150 SERIES & DEMON	MOR 65802
PLASTIC, 4500 SERIES	MOR 65803

Place your order at (479) 646-6988, Fax to (479) 646-5939, or visit [www.southwestspeed.com](http://www.southwestspeed.com)

# BARRY GRANT CARBURETORS

## ROAD DEMON - GAS - 4 BBL

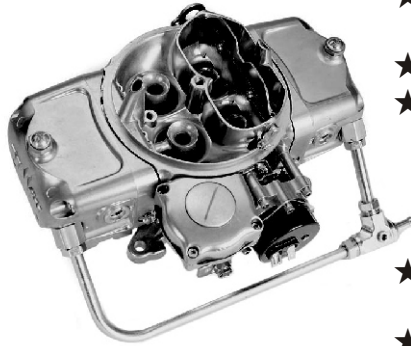

- ★ INLET KIT INCLUDED
- ★ ELECTRIC CHOKE
- ★ PERFECT FOR SMALL DISPLACEMENT V8 AND V6 ENGINES
- ★ VACUUM SECONDARY
- ★ 4 CORNER IDLE CIRCUITRY

## ROAD DEMON JR. - GAS - 4 BBL



- ★ MANUAL CHOKE
- ★ BUILT-IN POWER VALVE BLOW OUT PROTECTION
- ★ VACUUM SECONDARY
- ★ ADJUSTABLE PRIMARY JETS
- ★ 2 CORNER IDLE ADJUSTMENT
- ★ CONCENTRIC VENTURII

CFM	VACUUM ELECTRIC
525	BGF 4282020VE
625	BGF 4282010VE
725	BGF 4402020VE

CFM	VACUUM MANUAL
525	BGF 6282020VM
625	BGF 6282010VM
725	BGF 6402020VM

## RACE DEMON CARBURETORS - GAS & ALCOHOL - 4 BARREL

- ★ CONCENTRIC VENTURII
- ★ REPLACEABLE BOOSTERS
- ★ REPLACEABLE AIR BLEEDS
- ★ REPLACEABLE METERING BLOCK BLEEDS
- ★ BILLET BASEPLATES
- ★ BILLET METERING BLOCKS
- ★ LARGE CAPACITY FLOAT BOWLS
- ★ LARGE GLASS SIGHT WINDOWS FOR FLOAT ADJUSTMENT
- ★ FOUR-CORNER IDLE ADJUSTMENT
- ★ "QUIK RELEASE" NON-STICK GASKETS



CFM	OVAL TRACK		DRAG RACE		GENERAL COMP
	ALCOHOL	GAS	ALCOHOL	GAS	GAS ONLY
650	BGF 2282015OT	BGF 2282010OT	BGF 2282015DR	BGF 2282010DR	BGF 2282010GC
750	BGF 2402015OT	BGF 2402010OT	BGF 2402015DR	BGF 2402010DR	BGF 2402010GC
825	BGF 2423015OT	BGF 2423010OT	BGF 2423015DR	BGF 2423010DR	BGF 2423010GC
1000	BGF 2563015OT	BGF 2563010OT	N/A	BGF 2563010DR	BGF 2563010GC

## RACE DEMON REMOVABLE SLEEVE CARBURETORS - GAS & ALCOHOL - 4 BARREL

- ★ CONCENTRIC VENTURII
- ★ REPLACEABLE BOOSTERS
- ★ REPLACEABLE AIR BLEEDS
- ★ REPLACEABLE METERING BLOCK BLEEDS
- ★ BILLET BASEPLATES
- ★ BILLET METERING BLOCKS
- ★ REPLACEABLE VENTURII SLEEVES
- ★ LARGE CAPACITY FLOAT BOWLS
- ★ LARGE GLASS SIGHT WINDOWS FOR FLOAT ADJUSTMENT
- ★ FOUR-CORNER IDLE ADJUSTMENT
- ★ "QUIK RELEASE" NON-STICK GASKETS



CFM	OVAL TRACK		DRAG RACE		GENERAL COMP
	ALCOHOL	GAS	ALCOHOL	GAS	GAS ONLY
675	BGF 3282015OT	BGF 3282010OT	BGF 3282015DR	BGF 3282010DR	BGF 3282010GC
775	BGF 3402015OT	BGF 3402010OT	BGF 3402015DR	BGF 3402010DR	BGF 3402010GC
825	BGF 3423015OT	BGF 3423010OT	BGF 3423015DR	BGF 3423010DR	BGF 3423010GC
975	BGF 3503015OT	BGF 3503010OT	BGF 3503015DR	BGF 3503010DR	BGF 3503010GC
1025	BGF 3563015OT	BGF 3563010OT	N/A	BGF 3563010DR	BGF 3563010GC

Place your order at (479) 646-6988, Fax to (479) 646-5939, or visit [www.southwestspeed.com](http://www.southwestspeed.com)



# BARRY GRANT CARBURETORS

## SPEED DEMON & CLAW - GAS - 4BBL

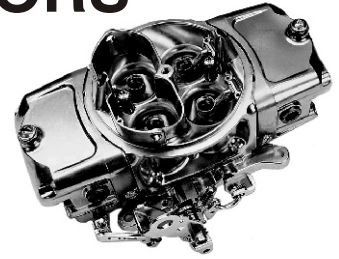

- ★AVAILABLE IN MECHANICAL OR WITH VACUUM SECONDARIES
- ★QUICK CHANGE VACUUM SECONDARY SPRING COVER
- ★LARGE GLASS FLOAT LEVEL SIGHT WINDOWS
- ★BILLET BASEPLATE WITH NEW IDLE-EZE
- ★INTEGRAL HI-FLOW CHOKE TOWER HOUSING
- ★BILLET METERING BLOCKS
- ★FOUR-CORNER IDLE CIRCUITRY
- ★LARGE CAPACITY FLOAT BOWLS
- ★VACUUM FITTINGS

CFM	SPEED DEMON		CLAW
	GEN. PERFORMANCE	VACUUM SECONDARY	SPORTS CLAW
650	BGF 1282010	BGF 1282010VE	BGF 5282010GP
750	BGF 1402010	BGF 1402010V	N/A
850	BGF 1563010	BGF 1563010V	N/A

## HOLLEY 2BBL & 4BBL - GAS & ALCOHOL

CFM	GOLD CLAW	PRO SPORTSMAN		STAGE THREE
	ALCOHOL	GAS	ALCOHOL	GAS
350 2BBL CARB	N/A	BGF 7448PS	N/A	N/A
390 4BBL CARB	N/A	BGF 80507PS5E	N/A	N/A
500 2BBL CARB	N/A	BGF 4412PS	BGF 9647PS	BGF 4412S3
975 4BBL CARB	BGF 7503015TM	N/A	N/A	N/A

## 2 BARREL RACE DEMONS - GAS & ALCOHOL



- ★CONTOURED AIR ENTRIES - SMOOTHES AIR ENTRY TO VENTURI WITH MINIMAL TURBULENCE
- ★STREAMLINED CHOKE HORN - LOW RESTRICTION DESIGN TO COMPLEMENT CONTOURED AIR ENTRIES
- ★REPLACEABLE BOOSTERS FOR ADDED TUNING CAPABILITIES
- ★SMOOTH CONCENTRIC VENTURI BORES - NO CORE SHIFTS TO UPSET FUEL ATOMIZATION, VENTURI BORES HAVE EXACTLY THE SAME DIMENSIONS AND VENTURI LOCATIONS
- ★REPLACEABLE 5-EMULSION HOLE BILLET METERING BLOCKS

CFM	NON-ADJUSTABLE BLEEDS		ADJUSTABLE BLEEDS	
	ALCOHOL	GAS	ALCOHOL	GAS
500 2BBL CARB	BGF 23722150T	BGF 23722100T	BGF 23726150T	BGF 23726100T

## MIGHTY DEMON - GAS

- ★750 CFM GAS - GENERAL COMPETITION CARBURETORS
- ★MOST COMMON TUNING PARTS ARE INTERCHANGEABLE FROM OTHER CARBURETORS
- ★REPLACEABLE AIR BLEEDS & IDLE FEED RESTRICTORS
- ★BILLET BASE PLATE & METERING BLOCKS
- ★NO CHOKE HORN

**PART #BGF 5402010GC**



## BG CARB FITTINGS

- ★ALUMINUM FITTINGS
- ★MALE OR FEMALE -8AN
- ★SHORT -6AN
- ★FITS ALL BG CLAW OR DEMON CARBS



DESCRIPTION	PART #
INLET, 9/16-24 TO -8 AN MALE	411-161
INLET, 9/16-24 TO -8 AN FEMALE	411-162
INLET, 9/16-24 TO -6 AN MALE	BGF 142113

## FILTERED INLET FITTING

- ★NON-CONSTRICTIVE STAINLESS STEEL MESH SCREEN
- ★7/8"-20 THREADS TO -8 AN
- ★FITS 4150/4160 HOLLEY CARBURETORS



**PART #BGF 140032**

Place your order at (479) 646-6988, Fax to (479) 646-5939, or visit [www.southwestspeed.com](http://www.southwestspeed.com)

# MAIN JETS

- ★MAIN JETS
- ★FIT HOLLEY CARBURETORS
- ★SOLD IN PAIRS



DESCRIPTION	PART #
CARB MAIN JETS, #60	BGF 230060
CARB MAIN JETS, #61	BGF 230061
CARB MAIN JETS, #62	BGF 230062
CARB MAIN JETS, #63	BGF 230063
CARB MAIN JETS, #64	BGF 230064
CARB MAIN JETS, #65	BGF 230065
CARB MAIN JETS, #66	BGF 230066
CARB MAIN JETS, #67	BGF 230067
CARB MAIN JETS, #68	BGF 230068
CARB MAIN JETS, #69	BGF 230069
CARB MAIN JETS, #70	BGF 230070
CARB MAIN JETS, #71	BGF 230071
CARB MAIN JETS, #72	BGF 230072
CARB MAIN JETS, #73	BGF 230073
CARB MAIN JETS, #74	BGF 230074
CARB MAIN JETS, #75	BGF 230075
CARB MAIN JETS, #76	BGF 230076
CARB MAIN JETS, #77	BGF 230077
CARB MAIN JETS, #78	BGF 230078
CARB MAIN JETS, #79	BGF 230079
CARB MAIN JETS, #80	BGF 230080
CARB MAIN JETS, #81	BGF 230081
CARB MAIN JETS, #82	BGF 230082
CARB MAIN JETS, #83	BGF 230083
CARB MAIN JETS, #84	BGF 230084
CARB MAIN JETS, #85	BGF 230085
CARB MAIN JETS, #86	BGF 230086
CARB MAIN JETS, #87	BGF 230087
CARB MAIN JETS, #88	BGF 230088
CARB MAIN JETS, #89	BGF 230089
CARB MAIN JETS, #90	BGF 230090
CARB MAIN JETS, #91	BGF 230091
CARB MAIN JETS, #92	BGF 230092
CARB MAIN JETS, #93	BGF 230093
CARB MAIN JETS, #94	BGF 230094
CARB MAIN JETS, #95	BGF 230095
CARB MAIN JETS, #96	BGF 230096
CARB MAIN JETS, #97	BGF 230097
CARB MAIN JETS, #98	BGF 230098
CARB MAIN JETS, #99	BGF 230099
CARB MAIN JETS, #100	BGF 2300100

# JET DRIVERS

- ★ALCOHOL OR MAIN JET DRIVER
- ★GRIP HANDLE
- ★LIGHTWEIGHT ALUMINUM
- ★ANODIZED FOR LONG LIFE

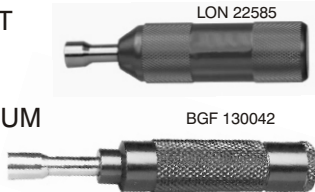

DESCRIPTION	PART #
MAIN JET DRIVER, LONGACRE	LON 22585
MAIN JET DRIVER, BARRY GRANT	BGF 130003
ALCOHOL JET DRIVER, BARRY GRANT	BGF 130042

# LARGE DIAMETER ALCOHOL JETS

- ★FITS BG ALCOHOL CARBURETORS
- ★JETS ARE NUMBERED TO ACTUAL FLOW ORIFICE SIZE
- ★SOLD IN PAIRS



DESCRIPTION	PART #
ALCOHOL JETS, .116	BGF 2900116
ALCOHOL JETS, .120	BGF 2900120
ALCOHOL JETS, .125	BGF 2900125
ALCOHOL JETS, .128	BGF 2900128
ALCOHOL JETS, .136	BGF 2900136
ALCOHOL JETS, .140	BGF 2900140
ALCOHOL JETS, .144	BGF 2900144
ALCOHOL JETS, .149	BGF 2900149
ALCOHOL JETS, .154	BGF 2900154
ALCOHOL JETS, .157	BGF 2900157
ALCOHOL JETS, .161	BGF 2900161
ALCOHOL JETS, .166	BGF 2900166
ALCOHOL JETS, .169	BGF 2900169
ALCOHOL JETS, .173	BGF 2900173
ALCOHOL JETS, .177	BGF 2900177
ALCOHOL JETS, .180	BGF 2900180
ALCOHOL JETS, .185	BGF 2900185
ALCOHOL JETS, .189	BGF 2900189
ALCOHOL JETS, .193	BGF 2900193
ALCOHOL JETS, .199	BGF 2900199
ALCOHOL JETS, .201	BGF 2900201
ALCOHOL JETS, .205	BGF 2900205
ALCOHOL JETS, .209	BGF 2900209
ALCOHOL JETS, .213	BGF 2900213
ALCOHOL JETS, .221	BGF 2900221
ALCOHOL JETS, .228	BGF 2900228

# MAIN JETS WITH PLATE

- ★44 JETS PER PLATE
- ★4 OF EACH JET



DESCRIPTION	PART #
JET PLATE WITH JETS, 50-60	BGF 232056-4
JET PLATE WITH JETS, 60-70	BGF 232067-4
JET PLATE WITH JETS, 70-80	BGF 232078-4
JET PLATE WITH JETS, 80-90	BGF 232089-4
JET PLATE WITH JETS, 90-100	BGF 232091-4
JET PLATE ONLY, MAIN JETS	BGF 130001

# ALCOHOL JETS WITH PLATE

- ★44 JETS PER PLATE
- ★4 OF EACH JET



DESCRIPTION	PART #
JET PLATE W/ JETS, .116 TO .161	BGF 292116-4
JET PLATE W/ JETS, .149 TO .189	BGF 292149-4
JET PLATE W/ JETS, .169 TO .209	BGF 292169-4
JET PLATE W/ JETS, .180 TO .228	BGF 292180-4

Place your order at (479) 646-6988, Fax to (479) 646-5939, or visit [www.southwestspeed.com](http://www.southwestspeed.com)

# CARBURETOR REBUILD KITS

★CONTAINS EVERY POSSIBLE GASKET AND SEAL ALONG WITH INSTRUCTIONS, POWER VALVE WITH NON-STICK RED OR BUNA REUSABLE GASKETS FOR FUEL BOWL, METERING BLOCK, & BOWL SCREWS

★THE ONE PIECE YOU'RE ALWAYS LOOKING FOR IS INCLUDED

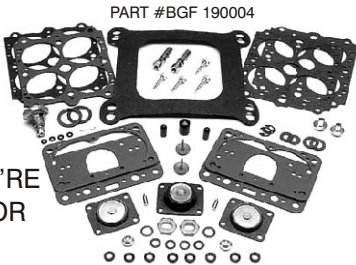
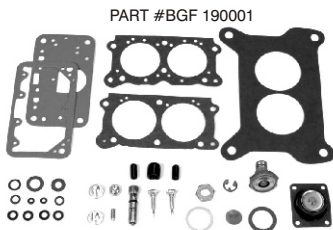

DESCRIPTION	PART #
ALCOHOL, 2 BBL, 2300 (N-S)	BGF 190001
ALCOHOL, 4 BBL, DOMINATOR (N-S)	BGF 190002
VACUUM SEC. GAS, 4150/4160 (N-S)	BGF 190003
MECH. SEC. GAS, 4150, 4 BBL (N-S)	BGF 190004
GAS 2 BBL, 2300 (NON-STICK)	BGF 190006
ALCOHOL, 4 BBL, 4150/4150HP (N-S)	BGF 190007
VAC. SEC. GAS, 4150/4160 (BUNA)	BGF 191003
ALC., 4 BBL, 4150/4150HP (BUNA)	BGF 191007

## JET CHANGE PACK

★FOR QUICK AND EASY JET CHANGES

★CONTAINS 5 BOWL, 5 METERING BLOCK, AND 8 BOWL SCREW GASKETS

★FITS 2300 2 BARREL, 4150, & 2 CIRCUIT 4500

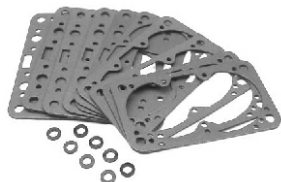

PART #BGF 190018

## QUICK KIT

★PREMIUM GRADE GASKETS WHEN A FULL REBUILD IS NOT NEEDED

★FITS 4 BARREL 4150 & 4150HP CARBURETORS

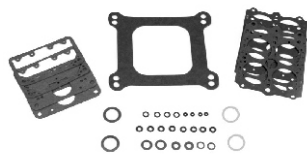

PART #BGF 192004

## CARB GASKETS BOWL GASKETS

★SOLD IN PACKS OF 5

★FITS CENTER PIVOT FUEL BOWLS

★REGULAR OR NON-STICK



DESCRIPTION	PART #
BOWL GASKETS (5)	BGF 190026
NON-STICK BOWL GASKETS (5)	BGF 190030

## CARB GASKETS 2 CIRCUIT METERING BLOCK

★FITS 2300, 4150, & 2 CIRCUIT 4500 CARBURETORS

★SOLD IN PACKS OF 5

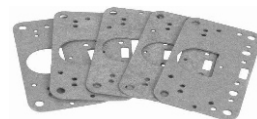

DESCRIPTION	PART #
METERING BLOCK GASKETS (5)	BGF 190027
METERING BLOCK GASKETS, N-S (5)	BGF 190031

## 3 CIRCUIT METERING BLOCK

★FITS 3 CIRCUIT 4500 CARBURETORS

★SOLD IN PACKS OF 5



DESCRIPTION	PART #
METERING BLOCK GASKETS (5)	BGF 190028
METERING BLOCK GASKETS, N-S (5)	BGF 190032

## BASE PLATE

★PREMIUM GRADE GASKETS, FOR THE PERFECT SEAL BETWEEN INTAKE AND CARB

★4150 OPEN HOLE & 4 HOLE AND 2300 2 BARREL (SOLD IN PACKS OF 10)

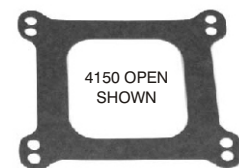

DESCRIPTION	PART #
4150, OPEN HOLE (10)	BGF 200035
4150, 4 HOLE (10)	BGF 200036
2300, 2 BARREL (10)	BGF 200039

## SQUIRTER GASKETS

★10 ACCELERATOR PUMP DISCHARGE NOZZLE GASKETS

PART #BGF 190017



## BOWL SCREW GASKETS

★SOLD IN PACKS OF 8

PART #BGF 190029

## ACCELERATOR PUMPS 30CC PUMP KIT

★REPLACEMENT ACCELERATOR PUMP

★INCLUDES HOUSING, DIAPHRAGM, SPRING, AND SCREWS

PART #BGF 120020



## 50CC PUMP KIT

★HIGH VOLUME PUMP

★DOUBLES CAPACITY OF STOCK PUMP FOR 4150 CARBS

PART #BGF 120073



Place your order at (479) 646-6988, Fax to (479) 646-5939, or visit [www.southwestspeed.com](http://www.southwestspeed.com)



# ACCELERATOR PUMP PARTS

## CAMS



- ★CHANGE PUMP TIMING
- ★COMPLETE WITH 8 CAMS
- ★FINE TUNE FUEL DELIVERY

**PART #BGF 120077**

## DIAPHRAGMS

- ★FITS 4412 2BBL OR 4BBL ALCOHOL
- ★FOR 50CC PUMP OR 30CC PUMP
- ★30CC PUMP DIAPHRAGMS ARE SOLD IN PAIRS

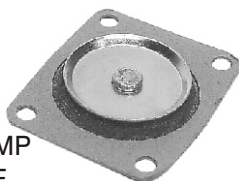

DESCRIPTION	PART #
ACCELERATOR PUMP, 30CC (2)	BGF 190015
ACCELERATOR PUMP, 50CC	BGF 190016

## FUEL DISCHARGE NOZZLES



- ★CONTROL THE ACCELERATOR PUMP VOLUME BY CHANGING THE PUMP NOZZLE

DESCRIPTION	PART #
TUBE TYPE NOZZLE, .025" (2 PIECES)	BGF 122025
TUBE TYPE NOZZLE, .035" (2 PIECES)	BGF 122035
TUBE TYPE NOZZLE, .037" (2 PIECES)	BGF 122037
TUBE TYPE NOZZLE, .042" (2 PIECES)	BGF 122042

## HOLLOW NOZZLE SCREW

- ★HOLDS THE ACCELERATOR PUMP NOZZLE IN PLACE



**PART #BGF 120072**

## POWER VALVES



- ★STANDARD VALVE FOR GAS
- ★HIGH FLOW VALVE FOR ALCOHOL
- ★RATED BY THE AMOUNT OF VACUUM TO OPEN
- ★GASKET INCLUDED

DESCRIPTION	PART #
2.5 STANDARD POWER VALVE	BGF 240025
3.5 STANDARD POWER VALVE	BGF 240035
4.5 STANDARD POWER VALVE	BGF 240045
5.5 STANDARD POWER VALVE	BGF 240055
6.5 STANDARD POWER VALVE	BGF 240065
7.5 STANDARD POWER VALVE	BGF 240075
8.5 STANDARD POWER VALVE	BGF 240085
3.5 HIGH FLOW POWER VALVE	BGF 240135
4.5 HIGH FLOW POWER VALVE	BGF 240145
5.5 HIGH FLOW POWER VALVE	BGF 240155
6.5 HIGH FLOW POWER VALVE	BGF 240165

# POWER VALVE PLUG

- ★COMPLETELY PLUGS POWER VALVE



**PART #BGF 240200**

## NEEDLES & SEATS

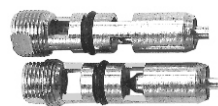

- ★STAINLESS OR VITON
- ★PROVIDES MAXIMUM FLOW
- ★KEEPS FUEL BOWL FULL
- ★SOLD IN PAIRS

DESCRIPTION	PART #
STAINLESS STEEL, .150, ALCOHOL, (2)	BGF 120005
VITON, .110, GAS, (2)	BGF 120006
VITON, .130, GAS, (2)	BGF 120013

## NEEDLE & SEAT HARDWARE

- ★1 PER NEEDLE & SEAT



**PART #BGF 120090**

## VENT BAFFLES

- ★SOLD IN PAIRS
- ★STOPS FUEL FROM SLOSHING OUT OF THE BOWL VENT TUBES, PREVENTING FLOODING

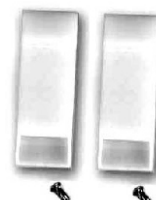

**PART #BGF 120007**

## SECONDARY VENT TUBES



- ★STANDARD STEEL SECONDARY LONG
- ★SOLD IN PAIRS

**PART #BGF 120066**

## SMALL PARTS HARDWARE

- ★ALL THE SMALL HARDWARE NEEDED TO SERVICE YOUR CARBURETOR

**PART #BGF 120150**



## SOFTWARE



- ★ALL THE SMALL SOFTWARE NEEDED TO SERVICE YOUR CARBURETOR

**PART #BGF 120160**

Place your order at (479) 646-6988, Fax to (479) 646-5939, or visit [www.southwestspeed.com](http://www.southwestspeed.com)

# FUEL BOWLS



- ★ SIGHT GLASSES ARE STANDARD ON ALL DEMON FUEL BOWLS
- ★ NO MORE FLOAT LEVEL PLUGS

DESCRIPTION	PART #
PRIMARY FUEL BOWL	BGF 421360
SECONDARY FUEL BOWL	BGF 421361
FUEL BOWL GASKETS, 5 PACK	BGF 190026
FUEL BOWL GASKETS, 5 PACK (N-S)	BGF 190030

## EXTENSION

- ★ INCREASES FUEL BOWL CAPACITY
- ★ SPECIAL ACCELERATOR LEVER GIVES PROPER GEOMETRY FOR MAXIMUM PUMP TRAVEL



PART #BGF 120035

## SIGHT PLUGS



PART #BGF 120060

- ★ REPLACES WORN OUT FUEL BOWL SIGHT PLUGS
- ★ SOLD IN PAIRS WITH WASHERS

## SCREWS

- ★ REPLACEMENT FUEL BOWL SCREWS FOR ALL POPULAR 4150 & 4500 AND 2 & 4 BARREL CARBURETORS
- ★ 2 1/2" LONG, 4 PER PACK



DESCRIPTION	PART #
FUEL BOWL SCREWS, HEX HEAD	BGF 120062
FUEL BOWL SCREWS, ALLEN HEAD	BGF 421386

# CARBURETOR FLOATS MODIFIED

- ★ STOPS FUEL SLOSH IN THE BOWL FROM INTERFERING WITH FLOAT DROP AND NEEDLE & SEAT OPENING

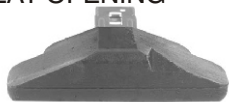

PART #BGF 120000



PART #BGF 120002

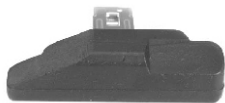

PART #BGF 120003

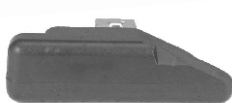

PART #BGF 120025

DESCRIPTION	PART #
PRIMARY/SECONDARY, ROAD RACE	BGF 120000
SECONDARY, OVAL TRACK	BGF 120002
PRIMARY, OVAL TRACK	BGF 120003
SECONDARY, TUNNEL RAM, DRAG	BGF 120025

NOTE: FOR A CONSTANT STREAM OF NEW PRODUCTS & UP-TO-THE-SECOND PRICING, VISIT [WWW.SOUTHWESTSPEED.COM](http://WWW.SOUTHWESTSPEED.COM)

# CARBURETOR FLOATS REPLACEMENT

- ★ REPLACEMENT FOR CENTER PIVOT BOWLS
- ★ AVAILABLE IN DURACON, BRASS, & NITROPHYL



PART #BGF 120069



PART #BGF 120070



PART #BGF 120071

## CLEARANCED

- ★ MADE FOR DRAG RACE APPLICATIONS USING JET EXTENSIONS IN THE SECONDARY FUEL BOWL
- ★ PERMITS COMPLETE FLOAT TRAVEL

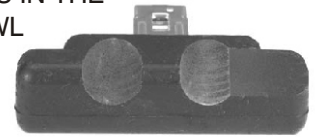

PART #BGF 120004

## FLOAT HARDWARE KIT



- ★ HARDWARE FOR MOUNTING A SINGLE FLOAT

PART #BGF 120093

## CATCH CAN

- ★ CHANGE JETS WITHOUT SPILLING FUEL ON ENGINE
- ★ ANGLE ALLOWS FOR MULTIPLE POSITIONS ON ANY CARBURETOR



PART #BGF 130040

## AIR BLEEDS

- ★ ENABLES YOU TO CUSTOMIZE YOUR CARBURETORS' FUEL CURVE
- ★ SCREW-IN ARE SOLD IN PACKS OF 10 & PRESS-IN ARE SOLD IN PACKS OF 4



DESCRIPTION	PART #
SCREW-IN AIR BLEEDS, 10/32, BLANK	BGF 200082
PRESS-IN AIR BLEEDS, .125" X .040"	BGF 421392

## BUTTERFLIES

- ★ REPLACEMENT BUTTERFLIES FOR STOCK OR CUSTOM APPLICATIONS

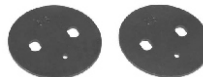

DESCRIPTION	PART #
1 11/16", #172 BUTTERFLIES (PAIR)	BGF 120105
1 11/16", #215 BUTTERFLIES (PAIR)	BGF 120108
1 3/4", #180 BUTTERFLIES (PAIR)	BGF 120110

## BOOSTER NUT DRIVER

- ★ LIGHTWEIGHT ALUMINUM

PART #BGF 130043



Place your order at (479) 646-6988, Fax to (479) 646-5939, or visit [www.southwestspeed.com](http://www.southwestspeed.com)

# CONVERSION KITS

- ★ CONVERTS GAS TO ALCOHOL OR ALCOHOL TO GAS
- ★ COMPLETE WITH METERING BLOCKS, CALIBRATION JETS, BOOSTER, NEEDLE & SEAT, & ACCELERATOR PUMP NOZZLES



DESCRIPTION	PART #
775 CFM (GAS TO ALCOHOL)	BGF 129003
775 CFM (ALCOHOL TO GAS)	BGF 129004

# CARB SPACERS PLASTIC

- ★ HARD PLASTIC SPACERS FOR 4150/4160 CARBS ARE AVAILABLE IN 4 HOLE & OPEN DESIGNS



THICK	CARB	PLENUM	PART #
1/2"	4150/4160	4 HOLE, 1.65" DIA.	410-943
1/2"	4150/4160	OPEN	410-945
1"	4150/4160	4 HOLE, 1.65" DIA.	410-955
1"	4150/4160	4 HOLE, 1.75" DIA.	MOR 64930
1"	4150/4160	OPEN	410-957
1"	4150/4160	OPEN	MOR 64940
2"	4150/4160	4 HOLE, 1.65" DIA.	410-960
2"	4150/4160	OPEN	410-962

# ALUMINUM

- ★ CAST ALUMINUM
- ★ OPEN DESIGN FOR 4150/4160 & 4500 CARBURETORS



THICK	CARB	PLENUM	PART #
1"	4150/4160	OPEN	MOR 64980
1"	4500	OPEN	MOR 64950

# PHENOLIC

- ★ INSULATING PHENOLIC
- ★ PRE-DRILLED FOR ALIGNMENT PINS



THICK	CARB	PLENUM	PART #
1/2"	4500	OPEN	MOR 64947

# VENTURI SLEEVES



- ★ COLOR CODED FOR SIZE
- ★ CNC MACHINED FOR CONSISTENT AIR FLOW
- ★ SOLD IN SETS OF 4

DESCRIPTION	PART #
ORANGE SLEEVES 1.064 x 1-7/16 (4)	BGF 127060
GREEN SLEEVES 1.280 x 1-11/16 (4)	BGF 127282
PURPLE SLEEVES 1.375 x 1-11/16 (4)	BGF 127372
RED SLEEVES 1.400 x 1-11/16 (4)	BGF 127402
BLUE SLEEVES 1.425 x 1-3/4 (4)	BGF 127423
GOLD SLEEVES 1.500 x 1-3/4 (4)	BGF 127503
BLACK SLEEVES 1.560 x 1-3/4 (4)	BGF 127563
SILVER SLEEVES 1.590 x 1-3/4 (4)	BGF 127593

# PHENOLIC ADAPTERS

- ★ INSULATING PHENOLIC ADAPTER
- ★ VERSATILE ADAPTER PUTS A 2300 2 BARREL HOLLEY CARBURETOR ONTO EITHER A 4150/4160 4 BARREL HOLLEY OR A QUADRAJET INTAKE MANIFOLD
- ★ SLOTTED DESIGN ALLOWS CARBURETOR TO BE MOVED FRONT TO BACK FOR MAXIMUM HORSEPOWER
- ★ INCLUDES ALL NECESSARY HARDWARE



THICK	CARB	INTAKE	PART #
1"	2300	4150/4160	BGF 110015
1"	2300	QUADRAJET	BGF 110016

# ALUMINUM ADAPTERS

- ★ CAST ALUMINUM ADAPTERS
- ★ 3/4" & 2" THICK ADAPTERS AVAILABLE FOR SEVERAL DIFFERENT CONVERSIONS



THICK	CARB	INTAKE	PART #
3/4"	4150/4160	QUADRAJET	410-930
2"	4500	4150/4160	MOR 65000
2"	QUADRAJET	4150/4160	MOR 64960

# PLENUM DIVIDER



- ★ LIGHTWEIGHT ALUMINUM CONSTRUCTION
- ★ FITS 4150 OPEN
- ★ 5/8" THICK SPACER
- ★ AIDS IN FUEL DISTRIBUTION

PART # BGF 110013

# CARB STUDS

- ★ 4 SIZES AVAILABLE
- ★ EACH KIT COMES WITH 4 STUDS, 4 WASHERS, & 4 NUTS



DESCRIPTION	PART #
1 3/8" STUD KIT	410-910
2" STUD KIT	410-911
2 1/2" STUD KIT	410-912
3 3/8" STUD KIT	410-913

Place your order at (479) 646-6988, Fax to (479) 646-5939, or visit [www.southwestspeed.com](http://www.southwestspeed.com)



# FUEL PRESSURE REGULATORS

## 2 PORT +

★3/8" NPT INLET & TWO 3/8" NPT OUTLETS

★ADJUSTABLE PSI OF EITHER 4-9 OR 3-12

★COMPACT DESIGN

★AVAILABLE IN CHROME & BILLET ANODIZED RED



DESCRIPTION	PART #
CHROME REGULATOR, ADJ 4-9 PSI	PCE 2851
RED BILLET REGULATOR, ADJ 3-12 PSI	PCE 2852D

## 4 PORT +

★-10 AN INLET, FOUR -6AN OUTLETS, & 1/8" NPT PRESSURE PORT FOR GAUGE

★ADJUSTABLE FROM 5 TO 15 PSI



PART #BGF 170023

# DIAPHRAGM BYPASSES SINGLE STAGE

★USE WITH MECHANICAL OR ELECTRIC PUMPS

★STEADY PRESSURE

★REBUILD KIT AVAILABLE FOR EASY PERIODIC MAINTENANCE

PART

#BGF 171021



## 2 STAGE W/ IDLE JET



★DIAPHRAGM DESIGN REACTS FASTER THAN TRADITIONAL POPPET BYPASS

★USED WITH BELT DRIVE PUMPS

★USES STANDARD MAIN JET FOR IDLE

PART #BGF 171020

## REBUILD KIT

★REBUILDS A SINGLE OR DOUBLE STAGE BYPASS

PART

#BGF 171025

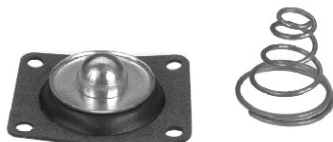

# CARB BOXES

★DURABLE POLYPROPYLENE

★FITS 2 & 4 BBL HOLLEY & DEMON

★PROTECTS LINKAGE DURING STORAGE; SNAP LATCH SECURES CARB DURING MOVEMENT

PART #410-998



# MECHANICAL FUEL PUMPS

★TWICE THE FLOW OF A STOCK PUMP WITH THIS LIGHTER HIGH FLOW PUMP

★FLOWS 150 GPH AT 6 PSI

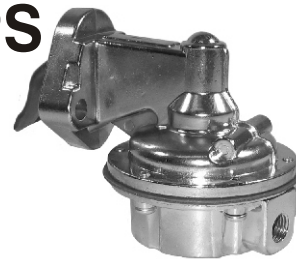

DESCRIPTION	PART #
SBC FUEL PUMP	PCE 2701
SBC FUEL PUMP, CHROME, 1/4" NPT I/O	PCE 2751
BBC FUEL PUMP	PCE 2702
BBC FUEL PUMP, CHROME	PCE 2752
SB FORD 302W FUEL PUMP	PCE 2703
SB FORD 302W FUEL PUMP, CHROME	PCE 2753
FORD 351C FUEL PUMP	PCE 2704
FORD 351C FUEL PUMP, CHROME	PCE 2754
HOLDEN 253/308 FUEL PUMP	PCE 2705
HOLDEN 253/308 FUEL PUMP, CHROME	PCE 2755

# ELECTRIC FUEL PUMPS

★AVAILABLE TO FLOW 115, 130, & 140 GPH

★PRESSURE IS PRESET ON THESE PUMPS AT 7 PSI, 14 PSI, OR 9 PSI

★COMPATIBLE WITH GAS, ALCOHOL & METHANOL

★REPLACES HOLLEY "RED", "BLUE", & "BLACK" PUMPS

★NOT FOR USE WITH FUEL INJECTION SYSTEMS



DESCRIPTION	PART #
ELECTRIC PUMP, 115 GPH, 7 PSI, "RED"	PCE 2801
ELECTRIC PUMP, 130 GPH, 14 PSI, "BLUE"	PCE 2802
ELECTRIC PUMP, 140 GPH, 9 PSI, "BLACK"	PCE 2803

\*#PCE 2802 REQUIRES A FUEL PRESSURE REGULATOR

# FUEL LOG BYPASS PILLS

★FUEL LOG DIAPHRAGM BYPASS PILLS OFFERED IN .10" INCREMENTS TO FINE TUNE THE FLOW OF THE FUEL; SOLD EACH



DESCRIPTION	PART #
BYPASS PILL, .040"	BGF 170040
BYPASS PILL, .050"	BGF 170050
BYPASS PILL, .060"	BGF 170060
BYPASS PILL, .070"	BGF 170070
BYPASS PILL, .080"	BGF 170080
BYPASS PILL, .090"	BGF 170090
BYPASS PILL, .100"	BGF 170100
BYPASS PILL, .110"	BGF 170110
BYPASS PILL, .120"	BGF 170120
BYPASS PILL, .130"	BGF 170130
BYPASS PILL, .140"	BGF 170140
BYPASS PILL, .150"	BGF 170150
BYPASS PILL, .160"	BGF 170160

Place your order at (479) 646-6988, Fax to (479) 646-5939, or visit [www.southwestspeed.com](http://www.southwestspeed.com)

# BG ELECTRIC FUEL PUMPS

## BG400-2



- ★400 GPH AT 18 PSI
  - ★EXTERNAL ADJUSTABLE BYPASS
  - ★LESS THAN 14.5 AMP DRAW
  - ★-10AN INLET & -8AN OUTLET
- PART #BGF 170001**

## BG280

- ★280 GPH
- ★FACTORY SET AT 20 PSI
- ★USES 12 VOLT OR 16 VOLT
- ★-10AN INLET & -10AN OUTLETS

**PART #BGF 170002**



# BELT DRIVE FUEL PUMP

- ★FOR ENGINES WITH HIGH VOLUME FUEL DEMAND (ESPECIALLY ALCOHOL)
- ★INCREASES FUEL DELIVERY AS RPM INCREASES
- ★REQUIRES A BYPASS WITH A RETURN LINE TO THE FUEL CELL

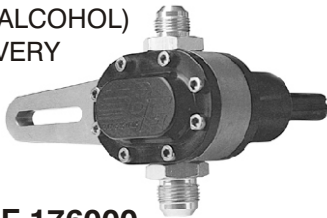

**PART #BGF 176000**

# BELT DRIVE KITS

- ★KITS CONTAIN ALL THE PARTS TO MOUNT A BELT DRIVE FUEL PUMP TO THE ENGINE BLOCK AND THE DRIVE KIT TO THE MOTOR & THE FUEL PUMP



BGF 176100 SHOWN

DESCRIPTION	PART #
COMPLETE DRIVE KIT, L/R, HIGH MT.	BGF 176100
COMPLETE DRIVE KIT, LEFT, LOW MT.	BGF 176200
PUMP BRKT. SBC, L/R, HIGH MT.	BGF 176050
DRIVE MANDREL & BOLT	BGF 176060
DRIVE PULLEY, 36 TOOTH, 5/8" ID	BGF 176070
CRANK PULLEY, 18 TOOTH, 1" ID	BGF 176071

# FUEL PUMP MOUNT PLATE

- ★SMALL BLOCK CHEVY
- ★CHROME PLATED W/ GASKET

**PART #411-076**



# BLOCK OFF PLATE



- ★BLOCKS OFF MECHANICAL FUEL PUMP MOUNTING HOLE
- ★CHROME PLATED WITH GASKET
- ★SMALL BLOCK CHEVY

**PART #411-075**

# SWS FUEL LOGS

- ★AVAILABLE FOR 4 BBL 4150/4160 & DEMON
- ★INCLUDES FUEL LOG TUBE, INLET & OUTLET FITTINGS, OUTLET FITTING CAP, & 2 CARB INLET LINES WITH EITHER CLEAR HOSE (4150 ECONO), RIGID TUBES (4150 RIGID), OR SWIVEL FITTINGS (DEMON)
- ★LIGHTWEIGHT ANODIZED ALUMINUM
- ★CLEARS ALL ACCELERATOR PUMPS

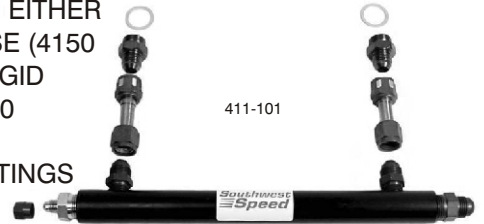

411-101



411-151

DESCRIPTION	PART #
4150 ECONO LOG, -8 AN IN, -6 AN OUT	411-100
4150 RIGID LOG, -8 AN IN, -4 AN OUT	411-101
4150 RIGID LOG, -8 AN IN, -6 AN OUT	411-103
4150 RIGID LOG, -8 AN IN, -8 AN OUT	411-104
4150 RIGID LOG, -10 AN IN, -6 AN OUT	411-105
4150 RIGID LOG, -10 AN IN, -8 AN OUT	411-107
DEMON FUEL LOG, -8 AN IN, -4 AN OUT	411-151
DEMON FUEL LOG, -8 AN IN, -6 AN OUT	411-153
DEMON FUEL LOG, -8 AN IN, -8 AN OUT	411-154
DEMON FUEL LOG, -10 AN IN, -6 AN OUT	411-155
DEMON FUEL LOG, -10 AN IN, -8 AN OUT	411-157
4150 FUEL LOG TUBE ONLY	411-120
DEMON FUEL LOG, TUBE ONLY	411-121
-8 AN MALE HOLLEY ADAPTER FITTING	411-110
-8 AN SWIVEL TUBE ASSEMBLY ONLY	411-112

# BARRY GRANT FUEL LOGS

- ★AIRCRAFT GRADE BILLET ALUMINUM
- ★HIGH VOLUME CAPABILITIES
- ★TRIPLE O-RING SEALED
- ★AVAILABLE WITH PILL BYPASS & DIAPHRAGM BYPASS
- ★#170021N & #170031 FEATURE A NEW ADJUSTABLE DESIGN THAT ALLOWS THE FUEL LOG TO BE CHANGED TO FIT 4150 & 4500 SERIES CARBURETORS



BGF 170020



BGF 170021N



BGF 170031

DESCRIPTION	PART #
LOG, 2 OUTLET, W/ BYPASS & PILLS	BGF 170020
LOG, 2 OUTLET	BGF 170021
LOG, 2 OUTLET, ADJUSTABLE	BGF 170021N
LOG, 2 OUT, ADJ. W/DIAPHRAGM BY.	BGF 170031

Place your order at (479) 646-6988, Fax to (479) 646-5939, or visit [www.southwestspeed.com](http://www.southwestspeed.com)

# FUEL FILTERS - INLINE

- ★AVAILABLE WITH 7 MICRON FIBER ELEMENT & 63 MICRON STAINLESS STEEL ELEMENT, WITH -6, -8, -10, -12, OR -16 AN END CAPS
- ★LIGHTWEIGHT ALUMINUM CONSTRUCTION WITH LARGE FILTERING AREA



DESCRIPTION	PART #
-6 AN FUEL FILTER, FIBER	411-210
-6 AN FUEL FILTER, STAINLESS STEEL	411-2106
-8 AN FUEL FILTER, FIBER	411-212
-8 AN FUEL FILTER, STAINLESS STEEL	411-2126
-10 AN FUEL FILTER, FIBER	411-214
-10 AN FUEL FILTER, STAINLESS STEEL	411-2146
-12 AN FUEL FILTER, FIBER	411-216
-12 AN FUEL FILTER, STAINLESS STEEL	411-2166
-16 AN FUEL FILTER, FIBER	411-218
-16 AN FUEL FILTER, STAINLESS STEEL	411-2186

REPLACEMENT PARTS	PART #
FIBER FILTER ELEMENT ONLY	411-222
STAINLESS STEEL ELEMENT ONLY	411-226
-6 AN END CAP	411-2299
-8 AN END CAP	411-230
-10 AN END CAP	411-232
-12 AN END CAP	411-234
-16 AN END CAP	411-2341
O-RING KIT, 2 PIECES	411-236
ELEMENT RETENTION SPRING	411-238

# INLINE FUEL FILTER BRACKETS

- ★ANODIZED BLACK 7075 T-6 ALUMINUM
- ★MOUNT TO SQUARE OR ROUND TUBING
- ★EASY-TO-USE, 2 PIECE DESIGN



DESCRIPTION	PART #
FILTER BRACKET, 1 1/4" ROUND TUBE	411-254
FILTER BRACKET, 1 1/2" ROUND TUBE	411-258
FILTER BRACKET, 1 3/4" ROUND TUBE	411-262
FILTER BRACKET, 2" SQUARE TUBE	411-280

NOTE: FOR A CONSTANT STREAM OF NEW PRODUCTS & UP-TO-THE-SECOND PRICING, VISIT [WWW.SOUTHWESTSPEED.COM](http://WWW.SOUTHWESTSPEED.COM)

# FUEL PRESSURE GAUGE

PART #411-194

- ★EASY TO READ, 1 1/2" DIAMETER FACE
- ★0 TO 15 PSI
- ★1/8" NPT OUTLET
- ★MOUNTS IN CAR OR ON FUEL LOG



# AIR FILTER HOUSINGS CENTERED

- ★SPUN ALUMINUM CONSTRUCTION
- ★14" DIAMETER
- ★FREE FLOWING DESIGN
- ★DEEP DISH FOR HOOD CLEARANCE



DESCRIPTION	PART #
14" CENTERED, TOP & BOTTOM	411-304
14" CENTERED, BOTTOM ONLY	411-309
14" CENTERED, TOP ONLY	411-310

# OFFSET

- ★OFFSET FOR HEI IGNITION
- ★WORKS WITH 2 BBL ADAPTER
- ★SPUN ALUMINUM CONSTRUCTION
- ★14" DIAMETER
- ★FREE FLOWING DESIGN
- ★DEEP DISH FOR HOOD CLEARANCE



DESCRIPTION	PART #
14" OFFSET, TOP & BOTTOM W/ STUD *	411-303
14" OFFSET, BOTTOM ONLY	411-308
14" OFFSET, TOP ONLY	411-310
OFFSET STUD ONLY, 1/4" COARSE	411-330
OFFSET STUD ONLY, 5/16" COARSE	411-331

\* SPECIFY STUD SIZE TO BE INCLUDED WITH PART #411-303

# SURESEALS

- ★LIGHTWEIGHT ALUMINUM
- ★REPLACEABLE O-RING INCLUDED
- ★ATTACHES TO AIR FILTER HOUSING TO KEEP OUT DIRT & GRIT
- ★DIMENSION REFERS TO HOW MUCH SEAL RAISES AIR CLEANER



DESCRIPTION	PART #
SURESEAL WITH O-RING, 1/4"	411-300
SURESEAL WITH O-RING, 3/4"	411-285
SURESEAL WITH O-RING, 1 1/4"	411-286
SURESEAL WITH O-RING, 2 1/4"	411-288
REPLACEMENT O-RING ONLY	411-301

Place your order at (479) 646-6988, Fax to (479) 646-5939, or visit [www.southwestspeed.com](http://www.southwestspeed.com)



## AIR FILTER HOUSING - 2 BARREL ADAPTER

- ★ADAPTS RACING AIR CLEANER TO 2 BBL. ROCHESTER CARB
- ★USE WITH OR WITHOUT SEAL



**PART #411-298**

## AIR FILTER GASKETS

- ★STURDY, NEOPRENE GASKET PROVIDES A POSITIVE, DURABLE SEAL BETWEEN THE AIR FILTER & THE CARB
- ★FITS DEMON, CLAW, & 4150/4160 4 BBL CARBS
- ★5 1/8" I.D.
- ★SOLD IN PACKS OF 10



**PART #411-2999**

## AIR FILTER STUD WITH NUT

- ★LIGHTWEIGHT 5/16" THREADED ALUMINUM STUD WITH NUT
- ★KNURLED THUMB SCREW
- ★ADJUSTABLE JAM NUT AND MOUNT NUT PREVENT OVER TIGHTENING



**PART #411-329**

## AIR FILTER NUTS WITH O-RINGS

- ★EASY GRIP, ALUMINUM WING NUTS & KNURLED NUTS WITH 1/4" & 5/16" THREADS
- ★COME WITH O-RINGS THAT PROVIDE A NO-LEAK SEAL ON THE AIR CLEANER



DESCRIPTION	PART #
AIR FILTER WING NUT, 1/4"	411-324
AIR FILTER KNURLED NUT, 1/4"	411-3242
AIR FILTER WING NUT, 5/16"	411-325
AIR FILTER KNURLED NUT, 5/16"	411-3252

## AIR FILTER OIL

- ★SPRAY-ON RED AEROSOL OIL
- ★HELPS COLLECT THE DIRT ON THE FILTER
- ★COMES IN 12OZ. CANS



DESCRIPTION	PART #
AIR FILTER OIL, 12 OUNCE CAN	411-381
AIR FILTER OIL, CASE OF 12 CANS	411-3811

## AIR FILTERS

- ★WASHABLE FABRIC OR DISPOSABLE PAPER FILTERS AVAILABLE
- ★REINFORCED MESH
- ★TRAPS DIRT & GRIT



DESCRIPTION	PART #
WASHABLE AIR FILTER, 14x2	411-332
WASHABLE AIR FILTER, 14x3	411-333
WASHABLE AIR FILTER, 14x4	411-334
WASHABLE AIR FILTER, 14x5	411-335
WASHABLE AIR FILTER, 14x6	411-336
WASHABLE AIR FILTER, 16x4	411-338
PAPER AIR FILTER, 14x3	411-383
PAPER AIR FILTER, 14x4	411-384
PAPER AIR FILTER, 14x5	411-385
PAPER AIR FILTER, 14x6	411-386
WIX PAPER AIR FILTER, 14x4	WFP 42096R

## EXTREME FLOW TOP AIR FILTER KIT

- ★14" FLOW TOP FILTER COMES WITH PROTECTIVE HOUSING TO PREVENT OVER-TIGHTENING
- ★PROVIDES INCREASED AIRFLOW
- ★KITS COMES COMPLETE WITH 14" FLOW TOP, 14" X 4" TALL FILTER, & 14" CENTERED BOTTOM



**PART #411-374**

## 14" FLOW TOP ONLY



- ★WASHABLE FLOW TOP UNIT INCREASES AIR FLOW
- ★14" DIAMETER

**PART #411-375**

NOTE: FOR A CONSTANT STREAM OF NEW PRODUCTS & UP-TO-THE-SECOND PRICING, VISIT [WWW.SOUTHWESTSPEED.COM](http://WWW.SOUTHWESTSPEED.COM)

Place your order at (479) 646-6988, Fax to (479) 646-5939, or visit [www.southwestspeed.com](http://www.southwestspeed.com)

# VALVE COVER & VENT BREATHERS

- ★3" O.D. CLAMP-ON VALVE COVER BREATHERS AVAILABLE SHIELDED & UNSHIELDED
- ★2" O.D. VENT BREATHERS AVAILABLE IN CLAMP-ON & SLIP-IN DESIGNS



DESCRIPTION	PART #
V.C. BREATH.,CLAMP-ON 1 3/8" TUBE	411-339
V.C. BREATH.,CLAMP-ON 1 1/2" TUBE	411-340
V.C. BREATH.,CLAMP-ON 1 3/8",SHIELDED	411-349
V.C. BREATH.,CLAMP-ON 1 1/2",SHIELDED	411-350
VENT BREATHER, CLAMPS ON 1/2" TUBE	411-356
VENT BREATHER, CLAMPS ON 5/8" TUBE	411-357
VENT BREATHER, CLAMPS ON 3/4" TUBE	411-358
VENT BREATHER, CLAMPS ON 1" TUBE	411-359
VENT BREATHER, SLIPS IN 3/8" HOSE	411-360
VENT BREATHER, SLIPS IN 1/2" HOSE	411-361
VENT BREATHER, SLIPS IN 5/8" HOSE	411-362
VENT BREATHER, SLIPS IN 3/4" HOSE	411-363
VENT BREATHER, SLIPS IN 1" HOSE	411-365

# AIR INDUCTION KIT - HIGH FLOW CHEVY

- ★FITS CAMARO/FIREBIRD 94-97 V8 & 94-95 3.4L V6
- ★INCLUDES ALL THE HARDWARE AND EASY TO FOLLOW INSTRUCTIONS
- ★AIR FILTER ELEMENT IS WASHABLE AND REUSABLE



PART #MOR 65845

# OVER-THE-TOP BREATHER/CRANK CASE PRE-FILTERS

- ★WASHABLE POLYESTER FABRIC
- ★FITS OVER FILTER WITH OR W/O SHIELD



COLOR	PART #
BLACK	OWC 11-25BK
BLUE	OWC 11-25BL
RED	OWC 11-25RD
ORANGE	OWC 11-25OR

COLOR	PART #
YELLOW	OWC 11-25YL
PINK	OWC 11-25PK
PURPLE	OWC 11-25PP

# FOAM PRE-FILTER

- ★WRAPS AROUND 14" x 5" AIR FILTERS
- ★HELPS KEEP LARGE DEBRIS FROM DAMAGING FILTER
- ★WASHABLE & REUSABLE



PART #MOR 65947

# OVER-THE-TOP PRE-FILTERS WITHOUT TOP

- ★POLYESTER FABRIC
- ★FITS OVER FILTER
- ★CATCHES DEBRIS
- ★PROLONGS FILTER LIFE



COLOR	14 x 3	14 x 4	14 x 5	14 x 6
BLACK	OWC 44-3BK	OWC 44-4BK	OWC 44-5BK	OWC 44-6BK
BLUE	OWC 44-3BL	OWC 44-4BL	OWC 44-5BL	OWC 44-6BL
ORANGE	OWC 44-3OR	OWC 44-4OR	OWC 44-5OR	OWC 44-6OR
PINK	OWC 44-3PK	OWC 44-4PK	OWC 44-5PK	OWC 44-6PK
PURPLE	OWC 44-3PP	OWC 44-4PP	OWC 44-5PP	OWC 44-6PP
RED	OWC 44-3RD	OWC 44-4RD	OWC 44-5RD	OWC 44-6RD
YELLOW	OWC 44-3YL	OWC 44-4YL	OWC 44-5YL	OWC 44-6YL

# WITH TOP

- ★POLYESTER FABRIC
- ★FITS OVER FILTER
- ★CATCHES DEBRIS
- ★PROLONGS FILTER LIFE



COLOR	14 x 4	14 x 5	14 x 6
BLACK	OWC 44-4TBK	OWC 44-5TBK	OWC 44-6TBK
BLUE	OWC 44-4TBL	OWC 44-5TBL	OWC 44-6TBL
ORANGE	OWC 44-4TOR	OWC 44-5TOR	OWC 44-6TOR
PINK	OWC 44-4TPK	OWC 44-5TPK	OWC 44-6TPK
PURPLE	OWC 44-4TPP	OWC 44-5TPP	OWC 44-6TPP
RED	OWC 44-4TRD	OWC 44-5TRD	OWC 44-6TRD
YELLOW	OWC 44-4TYL	OWC 44-5TYL	OWC 44-6TYL

# OVER-THE-TOP SCRUB BAGS

- ★LIGHTWEIGHT
- ★DRAW STRING TO HELP SECURE UNDER HIGH PRESSURE WASHING
- ★PREVENTS WATER & DEBRIS FROM ENTERING AIR CLEANER AND CRANK CASE BREATHERS DURING WASHING



3" SCRUB BAG SHOWN



14" SCRUB BAG SHOWN

DESCRIPTION	PART #
3" SCRUB BAG, BLACK	OWC DB11-25BK
3" SCRUB BAG, BLUE	OWC DB11-25BL
3" SCRUB BAG, RED	OWC DB11-25RD
14" SCRUB BAG, BLACK	OWC DB-14BK
14" SCRUB BAG, BLUE	OWC DB-14BL
14" SCRUB BAG, RED	OWC DB-14RD
MAGNETO BAG, BLACK	OWC 30-1264-BK
MAGNETO BAG, BLUE	OWC 30-1264-BL
MAGNETO BAG, RED	OWC 30-1264-RD

Place your order at (479) 646-6988, Fax to (479) 646-5939, or visit [www.southwestspeed.com](http://www.southwestspeed.com)

# CAST ALUMINUM PULLEYS PULLEY & BELT KITS

- ★ SMALL BLOCK CHEVY
- ★ 0% (1 TO 1) & 21% REDUCTION AVAILABLE
- ★ DOUBLE GROOVE
- ★ LIGHTWEIGHT ALUMINUM CONSTRUCTION
- ★ TWO MATCHED V-BELTS INCLUDED

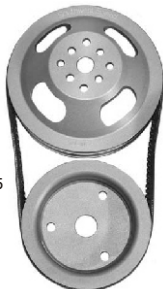

PART #410-625

DESCRIPTION	WATER PUMP	REDUCTION	PART #
PULLEY COMBO	SHORT	0% (1 TO 1)	410-623
PULLEY COMBO	LONG	0% (1 TO 1)	410-624
PULLEY COMBO	SHORT	21%	410-625
PULLEY COMBO	LONG	21%	410-626

## INDIVIDUAL CAST PULLEYS



PART #410-619



PART #410-621

- ★ SMALL BLOCK CHEVY
- ★ FOR SHORT OR LONG WATER PUMP
- ★ HARD ANODIZED FOR DURABILITY

DESCRIPTION	PART #
WATER PUMP PULLEY, 5 9/16"	410-619
WATER PUMP PULLEY, 7 1/16"	410-620
CRANK PULLEY, 5 9/16", ALIGNS W/LONG PUMP	410-621
CRANK PULLEY, 5 9/16", ALIGNS W/SHORT PUMP	410-622

## CRANK PULLEY SPACER

- ★ FOR CHEVY LOWER PULLEYS
- ★ .090" ALUMINUM
- ★ SPACES LOWER PULLEY TO MATCH UPPER PULLEY

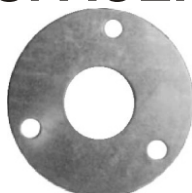

PART #410-570

## ALIGNMENT BOSS

- ★ ALIGNS LOWER PULLEY WITHOUT THE MANDREL
- ★ LIGHTWEIGHT ALUMINUM
- ★ USED WITH PULLEYS THAT HAVE 1" MANDREL BORE



PART #410-567

## WATER PUMP PULLEY SHIM KIT

- ★ FITS ALL GM AND FORD PUMPS
- ★ 5/8" OR 3/4" SHAFT
- ★ KIT CONTAINS ONE 1/16", ONE 3/32", AND ONE 1/8" SPACER

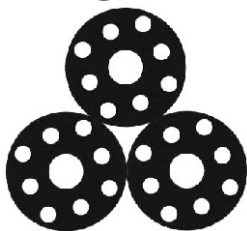

PART #410-498

## SOUTHWEST SPEED PULLEYS

- ★ USE THIS CHART TO SEE WHICH PULLEYS WILL GIVE YOU THE REDUCTION YOU NEED

REDUCTION CHART			
UPPER			
	5 9/16"	7 1/16"	
LOWER	4 7/8"	12%	31%
	5 9/16"	0%	21%
	5 7/8"	-6%*	17%

\*-6% REPRESENTS AN INCREASE RATHER THAN A REDUCTION

## BILLET CRANK PULLEYS

- ★ AVAILABLE TO ALIGN WITH CHEVY SHORT, CHEVY LONG, & FORD LONG WATER PUMPS
- ★ HARD ANODIZED, DOUBLE GROOVED
- ★ CHEVY PULLEYS ARE RELIEVED TO ACCEPT PUMP DRIVE MANDRELS



PART #410-615



PART #410-617

DESCRIPTION	PART #
4 7/8" PULLEY, ALIGNS W/ CHEVY SHORT PUMP	410-611
4 7/8" PULLEY, ALIGNS W/ CHEVY LONG PUMP	410-616
4 7/8" PULLEY, ALIGNS W/ FORD LONG PUMP	410-618
5 9/16" PULLEY, ALIGNS W/ CHEVY LONG PUMP	410-615
5 7/8" PULLEY, ALIGNS W/ FORD LONG PUMP	410-617

## FORD LOWER PULLEY ADAPTER

- ★ ALIGNS CHEVY WATER PUMP PULLEY TO FORD LOWER
- ★ ALLOWS USE OF DRIVE MANDREL IN FORD CRANK



PART #410-575

## ALTERNATOR PULLEY

- ★ LIGHTWEIGHT BILLET ALUMINUM
- ★ FITS GM/DELCO & MOST FORDS
- ★ 5" LARGE OUTSIDE DIAMETER REDUCES ALTERNATOR SPEED FOR HIGH ENGINE RPM APPLICATIONS



PART #410-580

## ALTERNATOR MOUNT KIT

- ★ FITS 1955-68 262-400 CHEVY'S
- ★ MOUNTS ALTERNATOR LOWER THAN STOCK LOCATION
- ★ WILL WORK W/POWER STEERING
- ★ WON'T WORK W/CAMARO & CHEVY II STOCK FRAMES
- ★ BOLTS TO THE FRONT OF THE BLOCK NEAR THE BOTTOM ON 2 BOLT HOLES WHERE TIMING COVER FITS TO OIL PAN

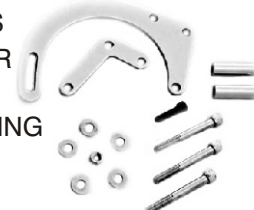

PART #410-5792

Place your order at (479) 646-6988, Fax to (479) 646-5939, or visit [www.southwestspeed.com](http://www.southwestspeed.com)



# KRC SERPENTINE PULLEY KITS

- ★INCLUDE SERPENTINE WATER PUMP PULLEY, CRANK PULLEY, CRANK ADAPTER, BOLTS, & BELT\*\*\*
- ★SETS MOTOR UP FOR USE WITH SERPENTINE POWER STEERING PULLEY
- ★CHEVY, FORD, & DODGE AVAILABLE
- ★FOR USE WITH SHORT WATER PUMP

DESCRIPTION	PART #
SBC KIT, HEAD MOUNT PUMP, 30% REDUCTION	KRC 37400 000
SBC KIT, BLOCK MOUNT PUMP, 30% REDUCTION	KRC 37401 000
SBC KIT, HEAD MOUNT PUMP, 15% REDUCTION	KRC 37410 001
SBC KIT, BLOCK MOUNT PUMP, 15% REDUCTION	KRC 37411 001
SBC KIT, HEAD MOUNT PUMP, 1 TO 1	KRC 37420 000
SBC KIT, BLOCK MOUNT PUMP, 1 TO 1	KRC 37421 000
FORD KIT, 3 BOLT BALANCER, 30% REDUCT.***	KRC 37600 000
FORD KIT, 4 BOLT BALANCER, 30% REDUCT.***	KRC 37605 000
FORD KIT, 3 BOLT BALANCER, 15% REDUCT.***	KRC 37610 000
FORD KIT, 4 BOLT BALANCER, 15% REDUCT.***	KRC 37615 000
FORD KIT, 3 BOLT BALANCER, 1 TO 1***	KRC 37620 000
FORD KIT, 4 BOLT BALANCER, 1 TO 1***	KRC 37625 000
DODGE KIT, BLOCK MOUNT, 30% REDUCTION	KRC 37501 000
DODGE KIT, BLOCK MOUNT, 15% REDUCTION	KRC 37511 000
DODGE KIT, BLOCK MOUNT, 1 TO 1	KRC 37521 000

\*\*\*FORD KITS ARE HEAD MOUNT & DO NOT INCLUDE THE BELT



# SOUTHWEST SPEED COMPLETE SBC FRONT ENGINE KITS

- ★THESE ARE THE PERFECT KITS TO EQUIP THE ENTIRE FRONT OF STANDARD SMALL BLOCK CHEVY MOTORS WITH EITHER V-BELT OR SERPENTINE PULLEYS
- ★SOUTHWEST SPEED'S COMPLETE FRONT ENGINE KITS INCLUDE WATER PUMP, POWER STEERING PUMP WITH PULLEY, POWER STEERING PUMP BRACKET, POWER STEERING TANK, WATER PUMP PULLEY, CRANK PULLEY, & BELT
- ★V-BELT KITS INCLUDE AN EXTRA BELT FOR THE FRONT GROOVES ON THE WATER PUMP & CRANK PULLEYS
- ★AVAILABLE WITH DIFFERENT SIZE PULLEYS FOR DIFFERENT REDUCTIONS

SWS SMALL BLOCK CHEVY FRONT ENGINE KITS					
PUMP	PULLEY	REDUCTION	P.S. BRACKET	TANK	PART #
STEEL	V-BELT	0% (1 TO 1)	HEAD	REMOTE	410-700
STEEL	V-BELT	0% (1 TO 1)	BLOCK	REMOTE	410-702
STEEL	V-BELT	21%	HEAD	REMOTE	410-704
STEEL	V-BELT	21%	BLOCK	REMOTE	410-706
STEEL	SERPENTINE	30%	HEAD	BOLT-ON	KRC 57711 110
STEEL	SERPENTINE	30%	BLOCK	BOLT-ON	KRC 57711 115
STEEL	SERPENTINE	15%	HEAD	BOLT-ON	KRC 57712 110
STEEL	SERPENTINE	15%	BLOCK	BOLT-ON	KRC 57712 115
STEEL	SERPENTINE	0% (1 TO 1)	HEAD	BOLT-ON	KRC 57713 110
STEEL	SERPENTINE	0% (1 TO 1)	BLOCK	BOLT-ON	KRC 57713 115



# KRC CHEVY CRATE MOTOR COMPLETE SERPENTINE KITS

- ★COMPLETE FRONT ENGINE KIT FOR YOUR CRATE MOTOR APPLICATION INCLUDES POWER STEERING PUMP & PULLEY, WATER PUMP, AND ALL THE BRACKETS, BELTS, HARDWARE, 15% WATER PUMP TO CRANK REDUCTION PULLEYS, & SPACERS TO MOVE THE WATER PUMP OUT TO CLEAR THE TAMPER-PROOF BOLTS ON THE TIMING COVER
- ★AVAILABLE WITH THE ALTERNATOR PULLEY, BRACKET, & BELT FOR BOTH THE DENSO\* & THE DELCO\*\*

KRC CHEVY CRATE MOTOR SERPENTINE KITS			
DESCRIPTION	P.S. BRACKET	TANK	PART #
COMPLETE KIT	HEAD	NO TANK	KRC 16312 010
COMPLETE KIT	BLOCK	NO TANK	KRC 16312 015
COMPLETE KIT	HEAD	BOLT-ON	KRC 16312 110
COMPLETE KIT	BLOCK	BOLT-ON	KRC 16312 115
KIT W/ DENSO ALTERNATOR PULLEY, BRKT, & BELT*	HEAD	NO TANK	KRC 16315 010
KIT W/ DENSO ALTERNATOR PULLEY, BRKT, & BELT*	BLOCK	NO TANK	KRC 16315 015
KIT W/ DENSO ALTERNATOR PULLEY, BRKT, & BELT*	HEAD	BOLT-ON	KRC 16315 110
KIT W/ DENSO ALTERNATOR PULLEY, BRKT, & BELT*	BLOCK	BOLT-ON	KRC 16315 115
KIT W/ DELCO ALTERNATOR PULLEY, BRKT, & BELT**	HEAD	NO TANK	KRC 16316 010
KIT W/ DELCO ALTERNATOR PULLEY, BRKT, & BELT**	BLOCK	NO TANK	KRC 16316 015
KIT W/ DELCO ALTERNATOR PULLEY, BRKT, & BELT**	HEAD	BOLT-ON	KRC 16316 110
KIT W/ DELCO ALTERNATOR PULLEY, BRKT, & BELT**	BLOCK	BOLT-ON	KRC 16316 115
KIT WITH IDLER ASSEMBLY	HEAD	NO TANK	KRC 16320 010
KIT WITH IDLER ASSEMBLY	BLOCK	NO TANK	KRC 16320 015
KIT WITH IDLER ASSEMBLY	HEAD	BOLT-ON	KRC 16320 110
KIT WITH IDLER ASSEMBLY	BLOCK	BOLT-ON	KRC 16320 115

\*WILL FIT 2 BOLT DENSO ALTERNATORS MEASURING 138MM (5.43") CENTER-TO-CENTER ON THE MOUNTING HOLES  
\*\*WILL FIT 2 BOLT DELCO ALTERNATORS MEASURING 156MM (6.14") CENTER-TO-CENTER ON THE MOUNTING HOLES

- ★AVAILABLE WITH IDLER ASSEMBLY TO HOLD MORE TENSION ON THE BELT

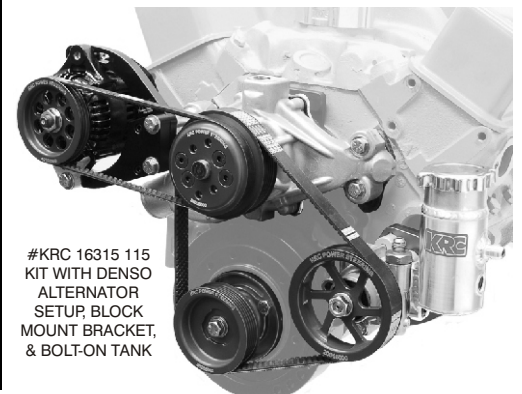

Place your order at (479) 646-6988, Fax to (479) 646-5939, or visit [www.southwestspeed.com](http://www.southwestspeed.com)

# SMALL BLOCK CHEVY ALUMINUM WATER PUMPS

- ★LIGHTWEIGHT ALUMINUM CONSTRUCTION
- ★SHORT OR LONG DESIGN
- ★DUAL FAN MOUNTING BOLT PATTERN

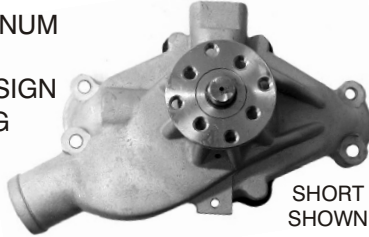

SHORT SHOWN

DESCRIPTION	PART #
SBC, SHORT WATER PUMP	410-550
SBC, LONG WATER PUMP	410-555

# ADDITIONAL WATER PUMPS

- ★LIGHTWEIGHT ALUMINUM PUMPS HAVE A CNC MACHINED IRON IMPELLER, RIBBED ALUMINUM HOUSING & A HEAVY-DUTY BALL/ROLLER BEARING ASSEMBLY, WHICH FLOWS 35% MORE COOLANT THAN A STOCK PUMP



DESCRIPTION	PART #
SBC, SHORT, CHROME PUMP	PCE 2901C
SBC, SHORT, POLISHED PUMP	PCE 2901P
SBC, LONG, CHROME PUMP	PCE 2902C
SBC, LONG, POLISHED PUMP	PCE 2902P
SBC LATE, LONG, REV. ROTATION	PCE 2903
BBC, SHORT	PCE 2904
BBC, LONG	PCE 2905
SB FORD, LEFT HAND	PCE 2906
SB FORD, RIGHT HAND	PCE 2907
FORD 351C	PCE 2908
FORD 460	PCE 2909

# ELECTRIC WATER PUMPS

- ★THESE PUMPS ELIMINATE UNNECESSARY WEIGHT & IMPELLER DRAG EXPERIENCED AT HIGH RPM
- ★ELECTRIC MOTORS FEATURE HEAVY-DUTY WINDINGS, PRECISION BALANCING, LONG-LIFE BRUSHES, STAINLESS STEEL SHAFT, & SEALED BALL BEARINGS
- ★MOUNTS DIRECTLY TO STOCK LOCATION
- ★DURABLE, LIGHTWEIGHT PUMPS FLOW 35% MORE COOLANT THAT A STOCK PUMP AS WELL



DESCRIPTION	PART #
SBC ELECTRIC PUMP	PCE 2926
BBC ELECTRIC PUMP	PCE 2927
SB FORD ELECTRIC PUMP	PCE 2928
FORD 351C ELECTRIC PUMP	PCE 2929
FORD 460 ELECTRIC PUMP	PCE 2930
HOLDEN V8 ELECTRIC PUMP	PCE 2931

# WATER OUTLET NECKS

#410-387 SHOWN



- ★STRAIGHT NECK & 45° NECK AVAILABLE
- ★O-RING TYPE SEAL
- ★WORKS WITH SMALL BLOCK CHEVY

DESCRIPTION	PART #
STRAIGHT NECK	410-385
45° NECK	410-387
45° NECK W/SENDER OUTLET	410-388

# WATER OUTLET SPACERS

- ★RAISES FILLER NECK
- ★FEATURES A PAIR OF NPT HOLES FOR SENDING UNIT & A PAIR OF NPT HOLES FOR RETURN LINES
- ★1" TALL ALUMINUM
- ★REUSABLE O-RING INCLUDED



#410-370 SHOWN

DESCRIPTION	PART #
1" TALL SPACER, 1/4" & 3/8" NPT HOLES	410-370
1" TALL SPACER, 3/8" & 1/2" NPT HOLES	410-372
REPLACEMENT O-RING ONLY	410-3699

# WATER OUTLET SPACER FILLER NECK ASSY.

- ★LOCATES NECK AT THE HIGHEST POINT IN THE COOLING SYSTEM TO BLEED OFF AIR
- ★CAN BE USED FOR EITHER RIGHT OR LEFT OUTLET LOCATION
- ★INCLUDES A 1/2" NPT HOLE FOR INSTALLING WATER TEMPERATURE SENDING UNIT AND TWO 1/4" NPT HOLES FOR RETURN LINES ON POPULAR AFTERMARKET HEADS

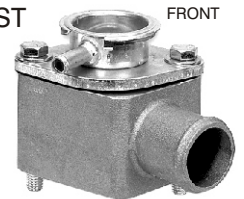

FRONT



REAR

PART #MOR 63420

# WATER OUTLET RESTRICTOR KIT

- ★MOUNTS UNDER WATER OUTLET
- ★CONTROLS THE FLOW OF WATER TO RADIATOR
- ★KIT CONTAINS 3 RESTRICTORS: ONE 5/8", ONE 3/4", & ONE 1"



PART #410-375

Place your order at (479) 646-6988, Fax to (479) 646-5939, or visit [www.southwestspeed.com](http://www.southwestspeed.com)

# COOLING FANS

## STEEL FANS

- ★NON-FLEX FANS
- ★STRONG STEEL CONSTRUCTION
- ★4 BLADE & 6 BLADE AVAILABLE



DESCRIPTION	4 BLADE	6 BLADE
UNIVERSAL STEEL, 15"	410-405	410-415
UNIVERSAL STEEL, 17"	410-407	410-417
UNIVERSAL STEEL, 18"	410-408	N/A
UNIVERSAL STEEL, 19"	410-409	N/A

## ALUMINUM FANS

- ★NON-FLEX, 6 BLADE FANS
- ★LIGHTWEIGHT ALUMINUM



DESCRIPTION	6 BLADE
UNIVERSAL ALUMINUM, 15"	410-425
UNIVERSAL ALUMINUM, 17"	410-427

## PLASTIC FANS

- ★TUFF-FLEX, 6 BLADE FANS
- ★1 PIECE ULTRALIGHT PLASTIC



DESCRIPTION	6 BLADE
UNIVERSAL PLASTIC, 15"	FLC 415
UNIVERSAL PLASTIC, 16"	FLC 416
UNIVERSAL PLASTIC, 17"	FLC 417
UNIVERSAL PLASTIC, 18"	FLC 418
2" SLOTTED FAN SPACER	FLC 14538

## FAN CLUTCH ELIMINATOR



- ★REPLACES CLUTCH
- ★LIGHTWEIGHT BILLET 6061-T6 ALUMINUM CONSTRUCTION
- ★DUAL BOLT PATTERN

**PART #410-510**

# FAN SHROUDS

## UNIVERSAL

- ★LIGHTWEIGHT ALUMINUM FAN SHROUDS DESIGNED TO BETTER FIT EACH WIDTH OF RADIATOR
- ★FIT 19" TALL, VERTICALLY MOUNTED RADIATORS

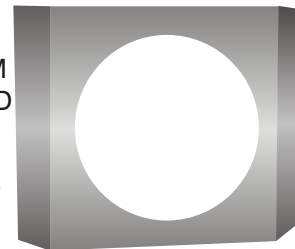

DESCRIPTION	PART #
UNIV. SHROUD FOR 22" WIDE RADIATORS	410-3101
UNIV. SHROUD FOR 24" WIDE RADIATORS	410-3102
UNIV. SHROUD FOR 26" WIDE RADIATORS	410-3103

## FAN SPACERS

- ★LIGHTWEIGHT BILLET 6061-T6 ALUMINUM
- ★ANODIZED BLACK
- ★KIT INCLUDES ALL BOLTS & WASHERS
- ★5/8" TO 3/4" SHAFT BUSHING INCLUDED, ALLOWING SPACERS TO WORK W/BOTH SHAFTS
- ★FEATURE 2 DIFFERENT MOUNTING PATTERNS



DESCRIPTION	PART #
FAN SPACER KIT, 1"	410-500
FAN SPACER KIT, 1 1/2"	410-502
FAN SPACER KIT, 2"	410-504
FAN SPACER KIT, 2 1/2"	410-506
FAN SPACER KIT, 3"	410-508
5/8" TO 3/4" SHAFT BUSHING ONLY	410-499

## V-BELTS & SERPENTINE BELTS

- ★SOLD EACH



LENGTH	PART #	LENGTH	PART #	LENGTH	PART #
<b>V-BELTS - 7/16" WIDE</b>					
25"	410-6272	32"	410-631	33 1/2"	410-634
29"	410-628	32 1/2"	410-632	39 1/2"	410-6396
30"	410-629	33"	410-633	40 1/2"	410-640
31 1/4"	410-630				
<b>3 RIB SERPENTINE</b>					
22"	410-6680	25"	410-6692	28"	410-6704
23"	410-6684	26"	410-6696	29 1/2"	410-6707
24"	410-6688	26.7"	410-6699	32 1/2"	410-6713
24 1/2"	410-6690	27"	410-6700	35"	410-6718
<b>6 RIB SERPENTINE</b>					
26"	410-6728	34 1/2"	410-679	38"	410-686
29 1/2"	410-6735	35"	410-680	39"	410-688
31 1/2"	410-6739	35 1/2"	410-681	41"	410-6888
32"	410-674	36"	410-682	44 1/2"	410-6902
32 1/2"	410-675	36 1/2"	410-683	46"	410-6908
33"	410-676	37"	410-684	55 1/2"	410-6946
33 1/2"	410-677	37.4"	410-6847	60 1/2"	410-6966

NOTE: FOR A CONSTANT STREAM OF NEW PRODUCTS & UP-TO-THE-SECOND PRICING, VISIT [WWW.SOUTHWESTSPEED.COM](http://WWW.SOUTHWESTSPEED.COM)

Place your order at (479) 646-6988, Fax to (479) 646-5939, or visit [www.southwestspeed.com](http://www.southwestspeed.com)



# SOUTHWEST SPEED ALUMINUM RADIATORS



- ★ BILLET ALUMINUM NECKS
- ★ 100% TIG WELDED CONSTRUCTION
- ★ CORES ARE FURNACE-BRAZED ON THE TANKS, WHICH IS A BETTER PROCESS THAN USING EPOXY
- ★ 1 1/2" INLETS & 1 3/4" OUTLETS
- ★ AVAILABLE FOR CHEVY'S & FORD'S

DIMENSIONS	CHEVY	FORD
19"H x 22"W x 3"D	410-202	410-212
19"H x 24"W x 3"D	410-204	410-214
19"H x 26"W x 3"D	410-206	410-216
19"H x 29"W x 3"D	410-208	410-218
19"H x 31"W x 3"D	410-211	410-221

# GRIFFIN ALUMINUM RADIATORS



- ★ BILLET ALUMINUM NECKS
- ★ 1 1/2" INLETS & 1 3/4" OUTLETS
- ★ AVAILABLE FOR CHEVY'S & FORD'S
- ★ ALSO AVAILABLE WITH AN OIL COOLER WITH -12 AN FITTINGS

DIMENSIONS	CHEVY	FORD
16"H x 28"W x 3"D	GRR 125241	GRR 126241
19"H x 22"W x 3"D	GRR 125182	GRR 126182
19"H x 24"W x 3"D	GRR 125202	GRR 126202
19"H x 26"W x 3"D	GRR 125222	GRR 126222
19"H x 28"W x 3"D	GRR 125242	GRR 126242
19"H x 31"W x 3"D	GRR 125272	GRR 126272
19"H x 24"W x 3"D*	GRR 125202D	GRR 126202D
19"H x 26"W x 3"D*	GRR 125222D	GRR 126222D
19"H x 28"W x 3"D*	GRR 125242D	GRR 126242D
19"H x 22"W x 1.5"D	GRR 245182	GRR 246182
19"H x 24"W x 1.5"D	GRR 245202	GRR 246202
19"H x 26"W x 1.5"D	GRR 245222	GRR 246222
19"H x 28"W x 1.5"D	GRR 245242	GRR 246242

\*WITH OIL COOLER WITH -12 AN FITTINGS

ALL RADIATOR WIDTHS ARE OUTSIDE TO OUTSIDE AT THE WIDEST POINT.

NOTE: FOR A CONSTANT STREAM OF NEW PRODUCTS & UP-TO-THE-SECOND PRICING, VISIT [WWW.SOUTHWESTSPEED.COM](http://WWW.SOUTHWESTSPEED.COM)

# RADIATOR CAPS

- ★ 3 DIFFERENT RATINGS AVAILABLE
- ★ SELF LOCKING CAPS FEATURE A SAFETY CATCH



DESCRIPTION	PART #
RADIATOR CAP, 22-24 LBS.	410-390
RADIATOR CAP, 25-27 LBS.	410-391
RADIATOR CAP, 29-31 LBS.	410-392

# RADIATOR REPAIR KIT



- ★ FOR USE ON ALUMINUM RADIATORS
- ★ USE LIKE SOLDER FOR ON-THE-SPOT REPAIR
- ★ INSTANT SETUP
- ★ ITS A MUST HAVE AT THE TRACK

PART #410-399

# RADIATOR MOUNTS

- ★ COMPLETE RADIATOR MOUNTING KIT
- ★ INCLUDES 2 WELD-ON BOTTOM BRACKETS & A 2-PIECE WELD-ON TOP BRACKET WITH BOLT



PART #410-305

# COOLING SYSTEM STOP LEAK

- ★ REPAIRS SMALL HOLES IN RADIATOR
- ★ STOPS MOST MINOR LEAKS IN THE COOLING SYSTEM FAST
- ★ CONTAINS NO METAL
- ★ SOLD IN 12 OUNCE BOTTLES



PART #940-020

# RADIATOR HOSE CLAMP KIT

- ★ 1/2" WIDE, PLATED BANDS
- ★ INCLUDES 2 CLAMPS TO FIT 1 5/16" - 2 1/4" O.D. HOSES & 2 CLAMPS TO FIT 1 9/16" - 2 1/2" O.D. HOSES
- ★ FOR USE WITH ANY RADIATOR



PART #410-296

NOTE: SEE PAGE 227 FOR AN EVEN LARGER SELECTION OF HOSE CLAMPS IN MANY DIFFERENT SIZES

Place your order at (479) 646-6988, Fax to (479) 646-5939, or visit [www.southwestspeed.com](http://www.southwestspeed.com)

# HEI DISTRIBUTORS

- ★ HEI DISTRIBUTORS ARE THE PERFECT UPGRADE FOR NON-COMPUTER CONTROLLED ENGINES
- ★ 100% NEW PIECES
- ★ FULLY CNC MACHINED; POLISHED HOUSING
- ★ ADJUSTABLE VACUUM ADVANCE CANISTER TO IMPROVE ECONOMY WHILE CRUISING
- ★ PREMIUM CAPS WITH BRASS TERMINALS & A LOW SATURATION IGNITION MODULE
- ★ HIGH-OUTPUT COIL WHICH PRODUCES 50,000 VOLTS THROUGH 7,500 RPM
- ★ 4340 CHROMEMOLY GEAR FOR USE WITH CAST & STEEL BILLET CAMS
- ★ ALSO OFFERS TRUE SPARK ALIGNMENT FOR INSTANTANEOUS RESPONSE AT HIGH RPM

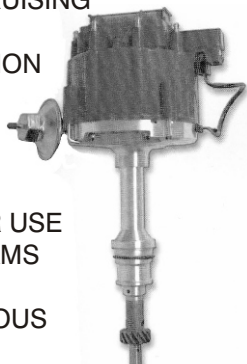

DESCRIPTION	PART #
HEI CHEVY	PCE 6001
HEI CHEVY WITH TACH DRIVE	PCE 6001TD
HEI CHEVY 6 CYLINDER	PCE 6001-6
HEI FORD 289/302W	PCE 6002
HEI FORD 351W	PCE 6003
HEI FORD 351C/460	PCE 6004
HEI HOLDEN 253/308	PCE 6005H
HEI CHRYSLER 318	PCE 6006
HEI CHRYSLER 440	PCE 6007
HEI PONTIAC	PCE 6008
HEI OLDSMOBILE	PCE 6009

# THUNDER SERIES HEI DISTRIBUTORS

- ★ FULLY CNC MACHINED POLISHED HOUSING, PRO BILLET BODY
- ★ CRAB STYLE CAP TO KEEP ALL WIRES IN PLACE
- ★ PRECISION WEIGHTS GLIDE ON NYLON FOR SMOOTH ADVANCEMENT
- ★ OVERSIZED SHAFT
- ★ BALL BEARING & SEAL
- ★ ADJUSTABLE VACUUM ADVANCE CANISTER TO IMPROVE ECONOMY WHILE CRUISING
- ★ PREMIUM CAPS WITH BRASS TERMINALS & A LOW SATURATION IGNITION MODULE
- ★ HIGH-OUTPUT COIL WHICH PRODUCES 50,000 VOLTS THROUGH 7,500 RPM
- ★ HARDENED GEAR READY FOR HYDRAULIC CAMS
- ★ OFFERS TRUE SPARK ALIGNMENT FOR INSTANTANEOUS RESPONSE AT HIGH RPM



DESCRIPTION	PART #
HEI THUNDER SER. CHEVY	PCE 6101
HEI THUNDER SER. FORD 289/302	PCE 6102
HEI THUNDER SER. FORD 351W	PCE 6103
HEI THUNDER SER. FORD 351C/460	PCE 6104
PRO HEI THUNDER CHEVY	PCE 6111
PRO HEI THUNDER FORD 289/302	PCE 6112

# PRO HEI DISTRIBUTORS

- ★ ENGINEERED & CREATED WITH A UNIQUE IGNITION MODULE & INTERNAL COIL THAT IS CAPABLE OF RUNNING ABOVE 9,000 RPM
- ★ PRODUCES 50% MORE CURRENT THAN STOCK UNITS & DELIVERS A MUCH MORE PRECISE TIMING SIGNAL AS WELL AS DWELL CONTROL
- ★ TIG WELDED TO THE TOP OF THE SHAFT IS AN ADJUSTABLE MECHANICAL ADVANCE ASSEMBLY, WHICH FEATURES CHROMEMOLY WEIGHTS FOR TIMING ADVANCE THROUGH THE ENTIRE RPM RANGE
- ★ THERE IS ALSO AN ADJUSTABLE VACUUM ADVANCE CANISTER TO IMPROVE ECONOMY WHILE CRUISING
- ★ ALL OF THESE FEATURES ARE ENCLOSED IN A GREAT LOOKING CNC MACHINED HOUSING FOR ACCURACY & INCREDIBLE STRENGTH
- ★ COMES COMPLETE & READY TO DROP IN WITH A HIGH-QUALITY ROTOR & CAP, FEATURING BRASS TERMINALS FOR GREAT SPARK TRANSFER; SIMPLY CONNECT A 12 VOLT SOURCE TO THE DISTRIBUTOR AND YOU'RE UP & RUNNING



DESCRIPTION	PART #
PRO HEI CHEVY	PCE 6011
PRO HEI FORD 289/302W	PCE 6012
PRO HEI FORD 351W	PCE 6013
PRO HEI FORD 351C/460	PCE 6014
PRO HEI HOLDEN 253/308	PCE 6015
PRO HEI CHRYSLER 318	PCE 6016
PRO HEI CHRYSLER 440	PCE 6017
PRO HEI PONTIAC	PCE 6018
PRO HEI OLDSMOBILE	PCE 6019
PRO HEI AMC 290-401	PCE 6021

# REPLACEMENT ACCESSORIES FOR HEI & PRO HEI DISTRIBUTORS

DESCRIPTION	PART #
PRO HEI MODULE, HIGH ENERGY	PCE 6040
REPLACEMENT HEI MODULE	PCE 6041
REPLACEMENT MAGNETIC PICKUP	PCE 6042
HARNESS & CAPACITOR	PCE 6043
ADVANCE CURVE KIT	PCE 6044
VACUUM ADVANCE LOCKOUT	PCE 6045
6 CYLINDER HEI PICKUP	PCE 6001-6PU
6 CYLINDER HEI RELUCTOR	PCE 6001-6REL

# VACUUM ADVANCE CANISTERS

- ★ REPLACEMENT VACUUM ADVANCE CANISTERS



DESCRIPTION	PART #
HEI ADJUSTABLE CANISTER	PCE 1071
CANISTER FOR 7000 SERIES DISTRIB.	PCE 1072

Place your order at (479) 646-6988, Fax to (479) 646-5939, or visit [www.southwestspeed.com](http://www.southwestspeed.com)

## READY-TO-RUN DISTRIBUTORS

- ★ 7000 SERIES READY-TO-RUN DISTRIBUTORS ARE THE PERFECT UPGRADE FOR OUTDATED POINTS DISTRIBUTORS OR BULKY HEI'S
- ★ ALL THAT IS REQUIRED IS TO INSTALL THE DISTRIBUTOR IN THE ENGINE, CONNECT 2 WIRES, & YOU'RE READY TO RUN
- ★ A MAINTENANCE-FREE MAGNETIC PICKUP ACCURATELY TRIGGERS THIS IGNITION
- ★ THE INCREASED OUTPUT OF THE INTERNAL IGNITION EASILY OUTPERFORMS STOCK IGNITIONS & WILL SMOOTH OUT THE ENGINE'S IDLE, IMPROVE STARTING, & PROVIDE A MUCH HIGHER RPM RANGE
- ★ FOR STABILITY & ENDURANCE, AN OVERSIZED STEEL SHAFT SPINS IN A TOP-MOUNTED SEALED BALL BEARING, WHILE AN EXTRA LONG SINTERED BUSHING GUIDES THE SHAFT AT THE BASE OF THE HOUSING
- ★ FEATURES AN ADJUSTABLE MECHANICAL ADVANCE, WHICH ALLOWS YOU TO CUSTOM TAILOR AN IGNITION CURVE TO MATCH YOUR ENGINE'S NEEDS
- ★ THERE IS ALSO A VACUUM ADVANCE CANISTER TO HELP IMPROVE ECONOMY



DESCRIPTION	PART #
READY-TO-RUN CHEVY	PCE 7001
READY-TO-RUN FORD 289/302W	PCE 7002
READY-TO-RUN FORD 351W	PCE 7003
READY-TO-RUN FORD 351C/460	PCE 7004
READY-TO-RUN HOLDEN 253/308	PCE 7005H
READY-TO-RUN CHRYSLER 318	PCE 7006
READY-TO-RUN CHRYSLER 440	PCE 7007
R2R MODULE ONLY	PCE 6046

## ULTIMATE HEI UPGRADE KIT

- ★ THE ULTIMATE HIGH ENERGY CONVERSION KIT HAS EVERYTHING YOU NEED TO MAKE YOUR EARLY MODEL GM HEI DISTRIBUTOR A GREAT PERFORMANCE DISTRIBUTOR
- ★ THE HEI MODULE FEATURES SPECIAL CIRCUITRY THAT PRODUCES 50% HIGHER COIL CURRENTS THAN A STOCK MODULE, RESULTING IN HIGHER SPARK ENERGY AT RACING RPM
- ★ TO ENSURE ALL OF THIS NEW POWER MAKES IT TO THE PLUGS, IT IS SUPPLIED WITH A HIGH-QUALITY DURABLE CAP WITH BRASS TERMINALS FOR SUPERIOR CONDUCTIVITY
- ★ COMES COMPLETE WITH A NEW DUST COVER



**PART #PCE 1054**

## PRO BILLET DISTRIBUTORS

- ★ 9000 SERIES PRO BILLET DISTRIBUTORS ARE DESIGNED FOR THE ENTHUSIASTS THAT ARE SERIOUS ABOUT PERFORMANCE
- ★ CNC MACHINED FROM BILLET, 6061-T6 ALUMINUM TO GIVE PRECISION TOLERANCES, HIGH STRENGTH, & INCREDIBLE ENDURANCE
- ★ EQUIPPED WITH A LARGE CAP THAT HAS "SPARK PLUG" STYLE TERMINALS FOR SECURE WIRE ATTACHMENT & MAXIMUM PROTECTION AGAINST CROSSFIRE
- ★ UNDER THE BRASS TERMINALS OF THE CAP & ROTOR IS AN EXTREMELY ACCURATE MAGNETIC PICKUP, WHICH NEVER REQUIRES ADJUSTMENT, FOLLOWED BY AN EASY-TO-ADJUST MECHANICAL ADVANCE ASSEMBLY
- ★ PRECISION WEIGHTS GLIDE ON NYLON FOR SMOOTH ADVANCEMENT & DIFFERENT SPRINGS ARE AVAILABLE SO A VARIETY OF ADVANCE CURVES CAN BE TUNED
- ★ THE 1/2" STEEL SHAFT THAT SPINS THE ADVANCE & RELUCTOR IS GUIDED BY A SEALED BALL BEARING & LONG SINTERED BUSHING; THIS COMBINATION PROVIDES STABLE TIMING & SPARK DELIVERY AT ANY RPM



DESCRIPTION	PART #
PRO BILLET CHEVY	PCE 9001
PRO BILLET FORD 289/302W	PCE 9002
PRO BILLET FORD 351W	PCE 9003
PRO BILLET FORD 351C/460	PCE 9004
PRO BILLET HOLDEN 253/308	PCE 9005H
PRO BILLET CHRYSLER 318	PCE 9006
PRO BILLET CHRYSLER 440	PCE 9007

## DISTRIBUTOR CLAMPS

- ★ EXTRA-THICK & HEAVY-DUTY TO ENSURE ADEQUATE RETENTION OF DISTRIBUTOR HOUSING
- ★ STUD MOUNTED TO ELIMINATE THREAD WEAR IN INTAKE MANIFOLD
- ★ SLOTTED FOR QUICK DISTRIBUTOR REMOVAL



DESCRIPTION	PART #
CHEVY HOLD DOWN, CHROME	416-050
CHEVY HOLD DOWN, RED	PCE 1091D
FORD HOLD DOWN	PCE 1092
HOLDEN HOLD DOWN	PCE 1093

## PICKUPS

- ★ EXTREMELY ACCURATE MAGNETIC & HALL EFFECT PICKUPS, WHICH NEVER REQUIRE ADJUSTMENT



DESCRIPTION	PART #
MAGNETIC PICKUP FOR 7000 SERIES	PCE 1051
HIGH-OUTPUT MAG. FOR 8000, 9000	PCE 1052
HIGH-OUTPUT HALL FOR 8000 R2R	PCE 1053
HIGH-OUTPUT HALL FOR 10000 SER.	PCE 1055

Place your order at (479) 646-6988, Fax to (479) 646-5939, or visit [www.southwestspeed.com](http://www.southwestspeed.com)



## PRO BILLET DISTRIBUTORS

- ★ 8000 SERIES PRO BILLET DISTRIBUTORS HAVE THE SAME CHARACTERISTICS AS THE 9000 SERIES, ALTHOUGH THE 8000'S ARE DESIGNED WITH A SMALL BASE & CAP TO SUIT ALL MAKES & MODELS
- ★ FEATURES SEALED BALL BEARINGS, SINTERED BUSHING, 1/2" HARDENED STEEL SHAFT, & EXTREMELY ACCURATE MAGNETIC PICKUP, WHICH NEVER REQUIRES ADJUSTMENT
- ★ THESE ARE MAINLY USED IN HIGH PERFORMANCE VEHICLES THAT HAVE SPACE LIMITATIONS AROUND THE ENGINE



DESCRIPTION	PART #
PRO BILLET CHEVY	PCE 8001
PRO BILLET CHEVY 6 CYLINDER	PCE 8001-6
PRO BILLET CHEVY 348-409	PCE 8010
PRO BILLET CHEVY MAGNETO	PCE 8011
PRO BILLET FORD 289/302W	PCE 8002
PRO BILLET FORD 351W	PCE 8003
PRO BILLET FORD 351C/460	PCE 8004
PRO BILLET FORD 2.3	PCE 8473
PRO BILLET FORD FLATHEAD 1939-48	PCE 8351
PRO BILLET FORD FLATHEAD 1949-53	PCE 8574
PRO BILLET FORD FE-BLOCK 390/427	PCE 8594
PRO BILLET HOLDEN 253/308	PCE 8005H
PRO BILLET CHRYSLER 318	PCE 8006
PRO BILLET CHRYSLER 440	PCE 8007
PRO BILLET PONTIAC	PCE 8008
PRO BILLET OLDSMOBILE	PCE 8009
PRO BILLET VOLKSWAGEN	PCE 8485
PRO BILLET AMC 304/360/401	PCE 8519

## PRO BILLET READY-TO-RUN

- ★ 8020 SERIES PRO BILLET READY-TO-RUN DISTRIBUTORS COME COMPLETE WITH A HIGH PERFORMANCE, HIGH OUTPUT INTERNAL IGNITION
- ★ THESE ARE SIMILAR IN CHARACTERISTICS TO THE 8000 SERIES, BUT WITHOUT THE NEED OF AN IGNITION BOX



DESCRIPTION	PART #
PRO BILLET R2R CHEVY	PCE 8021
PRO BILLET R2R CHEVY 6 CYLINDER	PCE 8021-6
PRO BIL. R2R FORD 289/302W, EARLY	PCE 8022E
PRO BIL. R2R FORD 289/302W, LATE	PCE 8022L
PRO BIL. R2R FORD 351W	PCE 8023
PRO BIL. R2R FORD 351C/460, EARLY	PCE 8024E
PRO BIL. R2R FORD 351C/460, LATE	PCE 8024L
PRO BILLET R2R HOLDEN 253/308	PCE 8025
PRO BILLET R2R CHRYSLER 318	PCE 8026
PRO BILLET R2R CHRYSLER 440	PCE 8027
R2R MODULE ONLY	PCE 6039

## LATE PRO BILLET DISTRIBUTORS

- ★ 10000 SERIES DISTRIBUTORS ARE DESIGNED FOR ENTHUSIASTS THAT ARE SERIOUS ABOUT PERFORMANCE
- ★ CNC MACHINED FROM BILLET 6061-T6 ALUMINUM TO GIVE PRECISION TOLERANCES, HIGH STRENGTH, & INCREDIBLE ENDURANCE
- ★ EQUIPPED WITH A LARGE CAP (FORD ONLY) THAT HAS "SPARK PLUG" STYLE TERMINALS FOR SECURE WIRE ATTACHMENT & MAXIMUM PROTECTION AGAINST CROSSFIRE
- ★ UNDER THE BRASS TERMINALS OF THE CAP & ROTOR IS AN EXTREMELY ACCURATE HALL EFFECT PICKUP, WHICH NEVER REQUIRES ADJUSTMENT
- ★ 1/2" STEEL SHAFT THAT SPINS THE IMPELLER IS GUIDED BY A SEALED BALL BEARING & LONG SINTERED BUSHING; THIS COMBINATION PROVIDES STABLE SIGNALS & SPARK DELIVERY AT ANY RPM



DESCRIPTION	PART #
LATE PRO BILLET CHEVY	PCE 10001
LATE PRO BILLET CHEVY 6 CYLINDER	PCE 10001-6
LATE PRO BILLET CHEVY LT1	PCE 10010
LATE PRO BIL. FORD 289/302W EARLY	PCE 10002
LATE PRO BIL. FORD 289/302W LATE	PCE 10003
LATE PRO BIL. FORD 351W	PCE 10004
LATE PRO BIL. FD. FLATHEAD, EARLY	PCE 10021
LATE PRO BIL. GM VORTEC 1996-03 SB/BB & CORVETTE PLASTIC, 6 CYL.	PCE 10031
LATE PRO BIL. GM VORTEC 1996-03 SB/BB & CORVETTE PLASTIC, 8 CYL.	PCE 10032
10000 SERIES MODULE ONLY	PCE 1064

## DISTRIBUTOR GEARS

- ★ HIGH STRENGTH BRONZE GEARS
- ★ BRONZE MATERIAL OFFERS SUPERIOR WEAR CHARACTERISTICS
- ★ CROSS-DRILLED FOR DOWEL PIN



DESCRIPTION	PART #
GEAR, CHEVY, .491" SHAFT (FOR HEI)	416-010
GEAR, CHEVY, .491" REVERSE ROTAT.	416-011
GEAR, CHEVY, .500" SHAFT	416-012
GEAR, FORD V8, .467" SHAFT	PCE 1084
GEAR, FORD V8, .500" SHAFT	PCE 1085
GEAR, FORD V8, .531" SHAFT	PCE 1086
GEAR, FORD 351/460, .500" SHAFT	PCE 1087
GEAR, CHRYSLER 318	PCE 1088

NOTE: FOR A CONSTANT STREAM OF NEW PRODUCTS & UP-TO-THE-SECOND PRICING, VISIT [WWW.SOUTHWESTSPEED.COM](http://WWW.SOUTHWESTSPEED.COM)

Place your order at (479) 646-6988, Fax to (479) 646-5939, or visit [www.southwestspeed.com](http://www.southwestspeed.com)

## DISTRIBUTOR CAPS & ROTORS

- ★ DESIGNED WITH PERFORMANCE IN MIND, THESE CAPS ARE MOLDED FROM A HIGH-QUALITY, VOLTAGE INSULATING DUPONT RYNITE MATERIAL
- ★ USES LOW-RESISTANCE TERMINALS FOR MAX. CONDUCTIVITY



DESCRIPTION	PART #
HEI CAP & ROTOR KIT	PCE 1031D
HEI CAP, ROTOR, COIL, & COIL COVER	PCE 1032D
HEI CAP	PCE 1001D
HEI COIL COVER	PCE 1002D
HEI ROTOR	PCE 1003D
CAP, SMALL CLIP-ON, MALE, 7000 SER.	PCE 1010D
CAP, LARGE SCREW-ON, MA. 8000,8020	PCE 1010D1
CAP, SMALL CLIP-ON, FEMALE, 7000	PCE 1011D
CAP, LARGE SCREW-ON, FE. 8000,8020	PCE 1011D1
ROTOR, PUSH-ON FOR 7000 SERIES	PCE 1012D
ROTOR, SCREW-ON FOR 8000, 8020	PCE 1012D1
CAP, MALE, FOR 9000 SERIES DISTRIB.	PCE 1021E
ROTOR FOR 9000 SERIES DISTRIB.	PCE 1022E
CAP, MALE, FOR 10000 SERIES DISTR.	PCE 1023
ROTOR FOR 10000 SERIES DISTRIB.	PCE 1024
CAP FOR #10001-6 DISTRIB. (6 CYL.)	PCE 1041
ROTOR FOR #10001-6 DISTRIB (6 CYL)	PCE 1042

## ULTIMATE HEI UPGRADE KIT

- ★ THE ULTIMATE HIGH ENERGY CONVERSION KIT HAS EVERYTHING YOU NEED TO MAKE YOUR EARLY MODEL GM HEI DISTRIBUTOR A GREAT PERFORMANCE DISTRIBUTOR
- ★ THE HEI MODULE FEATURES SPECIAL CIRCUITRY THAT PRODUCES 50% HIGHER COIL CURRENTS THAN A STOCK MODULE, RESULTING IN HIGHER SPARK ENERGY AT RACING RPM
- ★ TO ENSURE ALL OF THIS NEW POWER MAKES IT TO THE PLUGS, IT IS SUPPLIED WITH A HIGH-QUALITY DURABLE CAP WITH BRASS TERMINALS FOR SUPERIOR CONDUCTIVITY
- ★ COMES COMPLETE W/ A NEW DUST COVER



**PART #PCE 1054**

## HEI REPLACEMENT & HIGH-OUTPUT COILS

- ★ THESE ARE SOME OF THE MOST POWERFUL HEI COILS OF THEIR KIND
- ★ 52,000 VOLTS, WHILE STILL BEING ABLE TO FIT UNDER A STOCK HEI CAP



DESCRIPTION	PART #
HEI 52K VOLT COIL	PCE 2049
HEI 35K VOLT COIL	PCE 2050

## PC-91 HIGH-OUTPUT E-CORE IGNITION COIL

- ★ THE PC-91 "E-CORE" TECHNOLOGY COIL PRODUCES UP TO 70% MORE SPARK THAN STOCK COILS WITH OUTSTANDING RELIABILITY
- ★ THIS UNIT IS RECOMMENDED FOR CIRCLE TRACK, DRAG RACING, STREET, & STRIP
- ★ INTERNALLY, THE COIL HAS LARGE GAUGE WIRE WINDINGS FOR MAXIMUM SPARK CURRENT & VOLTAGE WITH BETTER HEAT DISSIPATION AT HIGH RPM; HIGH-VOLTAGE ARCING IS MINIMIZED THROUGH SCREW-ON CONNECTORS & A HIGH-TENSION TOWER
- ★ IDEAL FOR USE WITH CAPACITIVE DISCHARGE (CD) IGNITION SYSTEMS & ALL OF THE HIGH-OUTPUT IGNITIONS THAT WE STOCK

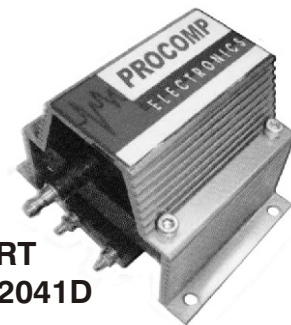

**PART #PCE 2041D**

## ELECTRONIC IGNITION COILS

- ★ HEAVY-DUTY ELECTRONIC COILS ARE GUARANTEED TO OUTPERFORM THE STOCK UNIT, DELIVERING OVER 30% MORE SPARK
- ★ CYLINDRICAL DESIGN & ARC-RESISTANT TOP RESULTS IN SUPERIOR PERFORMANCE
- ★ COILS DELIVER THE ADDED VOLTAGE REQUIRED BY STREET & STRIP PERFORMANCE ENGINES & WILL FIT MOST STANDARD OEM BRACKETS



DESCRIPTION	PART #
ELECTRONIC IGN. 12V COIL, MALE	PCE 2044
ELECTRONIC IGN. 12V COIL, FEMALE	PCE 2045

## ELECTRONIC TRANSFORMER IGNITION COILS

- ★ EPOXY-FILLED ELIMINATING INTERNAL VIBRATION, OIL LEAKS, & PRODUCING 50% MORE SPARK THAN STOCK
- ★ UNIVERSAL MOUNTING BRACKETS MAKE INSTALLATION SIMPLE

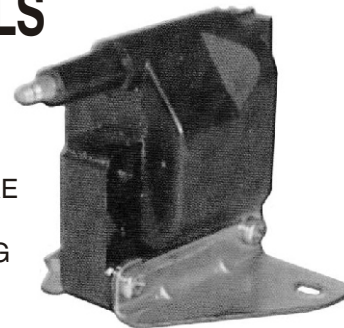

DESCRIPTION	PART #
EPOXY-FILLED COIL, MALE	PCE 2042
EPOXY-FILLED COIL, FEMALE	PCE 2043

NOTE: FOR A CONSTANT STREAM OF NEW PRODUCTS & UP-TO-THE-SECOND PRICING, VISIT [WWW.SOUTHWESTSPEED.COM](http://WWW.SOUTHWESTSPEED.COM)

Place your order at (479) 646-6988, Fax to (479) 646-5939, or visit [www.southwestspeed.com](http://www.southwestspeed.com)

# PC 6AL MULTI-SPARK CDI IGNITION BOXES

- ★ THE PC 6AL IS THE MOST POWERFUL IGNITION OF ITS TYPE AVAILABLE
- ★ IT IS A MULTI-SPARK, CAPACITOR DISCHARGED, ELECTRONIC IGNITION DESIGNED FOR HIGH PERFORMANCE CIRCLE TRACK, DRAG RACING, STREET, & STRIP APPLICATIONS
- ★ USES THE LATEST STATE OF THE ART DIGITAL TECHNOLOGY &, WHEN USED WITH #PCE 2041D PC-91 HIGH PERFORMANCE COIL, PRODUCES A SPARK GAP CURRENT THAT IS 3 TIMES GREATER THAN MOST SIMILAR SYSTEMS & ALMOST 8 TIMES THE SPARK OF STANDARD IGNITION
- ★ THIS UNIT CAN BE TRIGGERED BY MAGNETIC, HALL EFFECT, POINTS & CRANK TRIGGER PICKUPS
- ★ INCLUDES A SOFT TOUCH REV LIMITER, WHICH DOES NOT REQUIRE CHIPS
- ★ PRODUCES MULTIPLE SPARKS BETWEEN 0 AND 3000 RPM



DESCRIPTION	PART #
PC 6AL IGNITION BOX	PCE 2015
PC 6AL IGNITION, MAGNETIC PICKUP	PCE 2013
PC 6A IGNITION BOX	PCE 2017

# TACH ADAPTERS

- ★ CORRECTS THE OPERATION OF MOST VOLTAGE TRIGGERED TACHS THAT FAIL TO WORK DIRECTLY OFF THE TACH OUTPOST ON AFTERMARKET IGNITION BOXES



DESCRIPTION	PART #
POINTS OR AMPLIFIER TACH ADAPT.	PCE 2029
MAGNETIC PICKUP TACH ADAPTER	PCE 2030

# ELECTRONIC REV LIMITERS

- ★ LIMITERS ALLOW YOU TO SET AN RPM LIMIT THAT WILL SAVE YOUR ENGINE FROM OVER-REVVING OR DAMAGE IN THE EVENT OF DRIVELINE FAILURE
- ★ SIMPLY DIAL IN THE RPM YOU DESIRE AT THE FRONT OF THE UNIT, NO NEED FOR EXPENSIVE PILLS OR MODULES TO SET YOUR RPM
- ★ NOTE: NOT FOR USE WITH CDI UNITS



DESCRIPTION	PART #
SINGLE STAGE SAFETY LIMITER	PCE 2031
TWO STAGE SAFETY LIMITER	PCE 2032

NOTE: FOR A CONSTANT STREAM OF NEW PRODUCTS & UP-TO-THE-SECOND PRICING, VISIT [WWW.SOUTHWESTSPEED.COM](http://WWW.SOUTHWESTSPEED.COM)

# SPARK PLUG WIRES

- ★ 10.5MM HIGH-PERFORMANCE WIRES
- ★ 10.5MM WIRE OFFERS LESS RESISTANCE
- ★ FEATURES TRIPLE LAYER, SILICONE CONSTRUCTION & EXTRA INSULATION
- ★ DESIGNED TO WITHSTAND EXTRA AMOUNTS OF HEAT TO EXTEND THE LIFE OF THE WIRES
- ★ WIRES COME WITH 90° OR STRAIGHT SPARK PLUG ENDS & EITHER MALE OR FEMALE DISTRIBUTOR ENDS
- ★ AVAILABLE TO GO OVER OR UNDER THE HEADERS

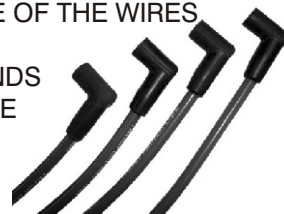

HEADER	DISTRIBUTOR		COLOR	PART #
	BOOTS	BOOTS		
OVER	90° MALE	90° FEMALE	BLACK	PCE 3270MK
OVER	90° MALE	90° FEMALE	BLUE	PCE 3270ME
OVER	90° MALE	90° FEMALE	RED	PCE 3270MD
UNDER	90° MALE	90° FEMALE	BLACK	PCE 3270UMK
UNDER	90° MALE	90° FEMALE	BLUE	PCE 3270UME
UNDER	90° MALE	90° FEMALE	RED	PCE 3270UMD
OVER	90° FEMALE	90° FEMALE	BLACK	PCE 3270FK
OVER	90° FEMALE	90° FEMALE	BLUE	PCE 3270FE
OVER	90° FEMALE	90° FEMALE	RED	PCE 3270FD
UNDER	90° FEMALE	90° FEMALE	BLACK	PCE 3270FK
UNDER	90° FEMALE	90° FEMALE	BLUE	PCE 3270FE
UNDER	90° FEMALE	90° FEMALE	RED	PCE 3270FD
UNDER	90° MALE	STRAIGHT, FEM.	BLACK	PCE 351SMK
UNDER	90° MALE	STRAIGHT, FEM.	BLUE	PCE 351SME
UNDER	90° MALE	STRAIGHT, FEM.	RED	PCE 351SMD
UNDER	90° FEMALE	STRAIGHT, FEM.	BLACK	PCE 351SFK
UNDER	90° FEMALE	STRAIGHT, FEM.	BLUE	PCE 351SFE
UNDER	90° FEMALE	STRAIGHT, FEM.	RED	PCE 351SFD
SPARK PLUG WIRE MALE BOOT ONLY				PCE 351M
SPARK PLUG WIRE FEMALE BOOT ONLY				PCE 351F

# DELUXE GAUGE & PANEL KITS

- ★ KITS INCLUDE:
  - \* 2 OR 3 GAUGE PANEL,
  - \* DUAL MINI-BRAKE GAUGE PANEL,
  - \* SWITCH PANEL FOR STANDARD IGNITION WITH 1 TOGGLE, 1 BUTTON, & 1 LIGHT, AND
  - \* MASTER BATTERY DISCONNECT PANEL



DESCRIPTION	PART #
DELUXE KIT WITH 2 GAUGE PANEL	390-120
DELUXE KIT WITH 3 GAUGE PANEL	390-121

# BATTERY DISCONNECTS SWITCH & PANEL

- ★ POWER SAFETY SHUTOFF
- ★ FITS IN BATTERY CABLE
- ★ EASY-TO-READ PANEL
- ★ LARGE, EASILY ACCESSIBLE HANDLE

**PART #390-091**



# ECONOMY

- ★ POWER SAFETY SHUTOFF
- ★ FITS IN BATTERY CABLE
- ★ REMOVABLE KEY-LIKE HANDLE
- ★ REPLACEMENT HANDLES ARE AVAILABLE (PART #390-0879)



**PART #390-088**

Place your order at (479) 646-6988, Fax to (479) 646-5939, or visit [www.southwestspeed.com](http://www.southwestspeed.com)



# BATTERY CABLE KITS

- ★AVAILABLE FOR TOP POST & SIDE POST BATTERIES, WITH OR WITHOUT MASTER DISCONNECT PANELS
- ★1/0 WELDING CABLE FOR HIGH CURRENT FLOW
- ★HEAVY DUTY TERMINAL ENDS ARE MADE OF CAST BRASS
- ★COMPRESSION DESIGN MAKES ENDS REUSABLE
- ★NYLON WIRE CLAMPS INCLUDED FOR SAFE & NEAT WIRING INSTALLATION

#499-961 RED 1/0 CABLE, 15' INCLUDED IN EACH KIT



#499-960 BLACK 1/0 CABLE, 2' INCLUDED IN EACH KIT



#499-923  
TOP POST  
BATTERY TERMINALS  
2 INCLUDED IN  
KIT #499-970 &  
KIT #499-974



#900-269  
NYLON WIRE CLAMPS  
16 INCLUDED IN EACH KIT

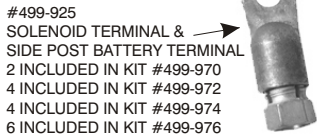

#499-925  
SOLENOID TERMINAL &  
SIDE POST BATTERY TERMINAL  
2 INCLUDED IN KIT #499-970  
4 INCLUDED IN KIT #499-972  
4 INCLUDED IN KIT #499-974  
6 INCLUDED IN KIT #499-976

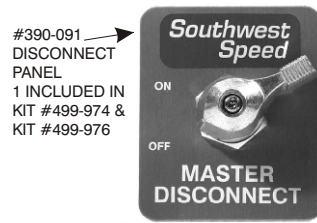

#390-091  
DISCONNECT  
PANEL  
1 INCLUDED IN  
KIT #499-974 &  
KIT #499-976

DESCRIPTION	PART #
KIT FOR TOP POST BATTERY	499-970
KIT FOR SIDE POST BATTERY	499-972
KIT WITH DISCONNECT FOR TOP POST	499-974
KIT WITH DISCONNECT FOR SIDE POST	499-976

# BATTERY CABLES

- ★HEAVY DUTY 1/0 CABLE IS AVAILABLE IN RED & BLACK
- ★PROVIDES MORE CRANKING AMP CAPABILITY & REDUCES VOLTAGE DROP
- ★PRICED PER FOOT
- ★MINIMUM ORDER OF 15 FOOT



DESCRIPTION	PART #
BLACK 1/0 BATTERY CABLE	499-960
RED 1/0 BATTERY CABLE	499-961

# NYLON CABLE CLAMPS

- ★9 AN NYLON CLAMPS
- ★FITS 1/0 BATTERY CABLE, AMONG OTHER ITEMS, MAKING FOR SAFE & NEAT INSTALLATIONS
- ★PRICED EACH & SOLD IN BOXES OF 100



PART #900-269

# BATTERY BOXES

- ★2 SIZES AVAILABLE IN WELD-ON & BOLT-ON
- ★BOLT-ON DESIGN ALLOWS FOR ADJUSTMENT ON THE FRAME
- ★LIGHTWEIGHT STEEL CONSTRUCTION
- ★EACH BOX COMES WITH ALUMINUM CLAMP BAR, 2 J-BOLTS, & 2 LOCK NUTS

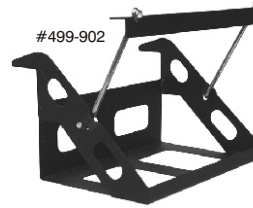

DESCRIPTION	PART #
9" WIDE, WELD-ON BATTERY BOX	499-900
9" WIDE, BOLT-ON BATTERY BOX	499-901
11" WIDE, WELD-ON BATTERY BOX	499-902
11" WIDE, BOLT-ON BATTERY BOX	499-903

9" WIDE BOXES HAVE INSIDE DIMENSIONS OF 8 7/8" WIDE X 7 1/8" DEEP  
11" WIDE BOXES HAVE INSIDE DIMENSIONS OF 11" WIDE X 7 1/8" DEEP

# TERMINAL ENDS

- ★COMPRESSION DESIGN GIVES YOU THE ABILITY TO REUSE EACH END AGAIN & AGAIN
- ★ENDS CAN BE SOLDERED IF DESIRED OR IF A CRACKED HOUSING DICTATES
- ★#499-923 TERMINAL SLIPS ONTO TOP BATTERY POSTS
- ★#499-925 TERMINAL SLIPS ONTO 3/8" SIDE BATTERY POSTS & 3/8" SOLENOID POSTS

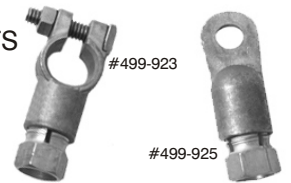

DESCRIPTION	PART #
TOP POST TERMINAL	499-923
SIDE POST & SOLENOID TERMINAL	499-925

# TERMINAL END BOOTS

- ★TERMINAL INSULATORS PROVIDE ADDED PROTECTION ON BATTERY & ALTERNATOR CABLES AGAINST CORROSION & HARMFUL CHEMICALS
- ★IMPROVES APPEARANCE & PROVIDES PROLONGED CABLE LIFE
- ★AVAILABLE FOR CLAMP-ON TOP POSTS & 3/8" STUDS (SIDE POST & SOLENOID)

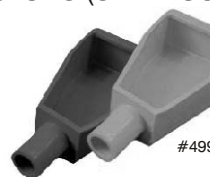

#499-9252



#499-9232

DESCRIPTION	PART #
TOP POST BOOTS, 6-4 GAUGE WIRE	499-9251
TOP POST BOOTS, 1/0 & 2/0 GAUGE	499-9252
3/8" STUD BOOTS, 1/0 & 2/0 GAUGE	499-9232

#499-9251 IS A PAIR WITH 2 RED BOOTS  
#499-9252 IS A PAIR WITH 1 RED & 1 BLACK BOOT  
#499-9232 IS A PAIR WITH 1 RED & 1 BLACK BOOT

Place your order at (479) 646-6988, Fax to (479) 646-5939, or visit [www.southwestspeed.com](http://www.southwestspeed.com)

# DENSO ALTERNATORS

## TRUE ONE WIRE UNITS

- ★ TRUE ONE WIRE HOOKUP W/ 14.9 SET VOLTAGE
- ★ HIGH OUTPUT TO WEIGHT RATIO
- ★ BLACK HEAT DISPERSANT COATING
- ★ LOW DRAG, HIGH SPEED BEARING
- ★ AVAILABLE IN XS VOLT
- ★ PULLEY NOT INCLUDED
- ★ THE 93MM DIAMETER STATOR HOUSING IS A COMPACT ALTERNATOR W/ A 50 AMP OUTPUT THAT IS MORE THAN ENOUGH FOR MOST FORMS OF RACING

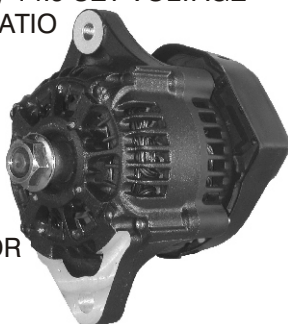

STATOR HOUSING	VOLTAGE	IDLE	MAX.	WEIGHT	PART #
93MM	12 VOLT	30 AMP	50 AMP	5.68#	PMM 8162
93MM	XS VOLT	30 AMP	50 AMP	5.68#	PMM 8168
93MM	12 VOLT	10 AMP	75 AMP	5.68#	PMM 8182
93MM	XS VOLT	10 AMP	75 AMP	5.68#	PMM 8188
102MM	12 VOLT	15 AMP	80 AMP	6.78#	PMM 8122
102MM	XS VOLT	15 AMP	80 AMP	6.78#	PMM 8128
110MM	12 VOLT	25 AMP	95 AMP	7.96#	PMM 8132
110MM	XS VOLT	25 AMP	95 AMP	7.96#	PMM 8138
118MM	12 VOLT	85 AMP	120AMP	10.6#	PMM 8142
118MM	XS VOLT	85 AMP	120AMP	10.6#	PMM 8148

# JUMPER WIRE UNITS

- ★ JUMPER WIRE ALTERNATORS - IGNITION TERMINAL JUMPED TO BATTERY (SET VOLT 14.0)
- ★ CONNECT TO AN IGNITION SWITCHED POSITIVE SOURCE FOR OPTIMAL USE
- ★ NATURAL FINISH
- ★ STEEL PULLEY INCLUDED
- ★ THE 93MM DIAMETER STATOR HOUSING IS A COMPACT ALTERNATOR WITH A 50 AMP OUTPUT THAT IS MORE THAN ENOUGH FOR MOST FORMS OF RACING

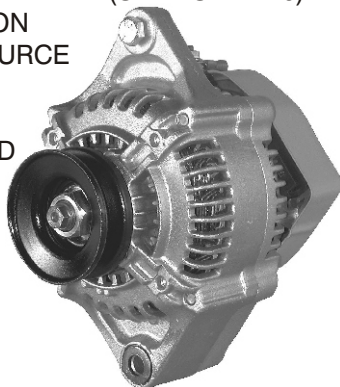

STATOR HOUSING	VOLTAGE	IDLE	MAX.	WEIGHT	PART #
93MM	12 VOLT	30 AMP	50 AMP	5.68#	PMM 8172
110MM	12 VOLT	45 AMP	60 AMP	8.32#	PMM 8102

93MM DIAGRAM

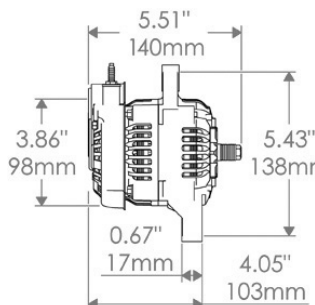

110MM DIAGRAM

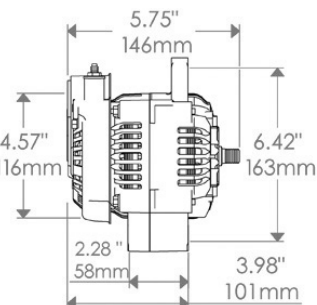

# DELCO ALTERNATORS

## DELCO CS121 LATE STYLE

- ★ TRUE ONE WIRE HOOKUP W/ 14.6 SET VOLTAGE
- ★ HIGH OUTPUT TO WEIGHT RATIO
- ★ NATURAL FINISH
- ★ GOLD BATTERY POST
- ★ AVAILABLE IN XS VOLT
- ★ #PMM 8060 COMES WITH STEEL V-BELT PULLEY
- ★ AVAILABLE WITH 2 BOLT STRAIGHT MOUNTING PATTERN OR 3 BOLT MOUNTING PATTERN



2 BOLT STRAIGHT PATTERN DIAGRAM

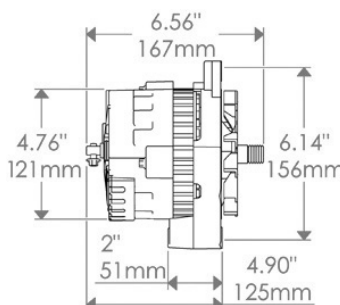

3 BOLT PATTERN DIAGRAM

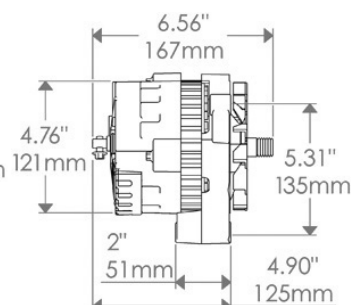

MOUNT. PATTERN	VOLTAGE	IDLE	MAX.	WEIGHT	PART #
2 BOLT	12 VOLT	45 AMP	70 AMP	9.50#	PMM 8060
2 BOLT	12 VOLT	60 AMP	100AMP	8.24#	PMM 8062
2 BOLT	XS VOLT	60 AMP	100AMP	8.24#	PMM 8068
3 BOLT	12 VOLT	60 AMP	100AMP	8.24#	PMM 8072
3 BOLT	XS VOLT	60 AMP	100AMP	8.24#	PMM 8078

# DELCO 12SI EARLY STYLE

- ★ CAN BE USED AS A ONE WIRE OR THREE WIRE HOOKUP
- ★ INCLUDES FAN & V-BELT PULLEY
- ★ FITS NUMEROUS STOCK APPLICATIONS, INCLUDING 67-86 CAMARO, 63-88 EL CAMINO, 63-79 IMPALA, 63-85 CUTLASS, 67-86 FIREBIRD, MANY CHEVY & GMC TRUCKS, AS WELL AS NUMEROUS JEEPS; SEE southwestspeed.com FOR THE COMPLETE FITMENT LIST
- ★ FEATURES SMOOTH DIE-CAST HOUSING & GOLD BATTERY POST

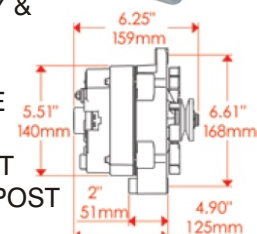

DESCRIPTION	IDLE	MAX.	PART #
12SI, NATURAL FINISH	70 AMP	100 AMP	PMM 8002
12SI, CHROME	70 AMP	100 AMP	PMM 17294
12SI, POLISHED	70 AMP	100 AMP	PMM 27294
12SI, CHROME	80 AMP	140 AMP	PMM 37293
12SI, POLISHED	80 AMP	140 AMP	PMM 67293
12SI, CHROME, W/NOSE	80 AMP	140 AMP	PMM 37294
12SI, POLISH, W/NOSE	80 AMP	140 AMP	PMM 67294

NOTE: WE ALSO HAVE DELCO CS130 ALTERNATORS, AS WELL AS POWERMASTER'S "FORD UPGRADE" ALTERNATORS. SEE southwestspeed.com FOR THE COMPLETE SELECTION.

Place your order at (479) 646-6988, Fax to (479) 646-5939, or visit [www.southwestspeed.com](http://www.southwestspeed.com)



## RACING ALTERNATOR KITS

- ★ OUR RACING ALTERNATOR KITS COVER ALL FORMS OF CIRCLE TRACK RACING & GIVE THE RACER SOME CHOICES FOR MOUNTING STYLES
- ★ ALL KITS COME WITH A TRUE ONE WIRE ALTERNATOR, ALTERNATOR PULLEY, ALTERNATOR DRIVE PULLEY FOR THE FRONT OF THE WATER PUMP, PROPER BRACKET, DRIVE BELT, & NECESSARY HARDWARE

### HIGH MOUNT RACING ALTERNATOR KIT

- ★ DESIGNED FOR ALL CIRCLE TRACK APPLICATIONS
- ★ MOVES THE ALTERNATOR TO A MORE FAVORABLE, SPACIOUS MOUNTING LOCATION
- ★ MOUNTS TO SBC WATER PUMP BOLTS
- ★ COMPLETE WITH 70 AMP ALTERNATOR, 3 GROOVE SERPENTINE BELT, & PULLEY
- ★ THREADED MOUNTING TUBE & ROD ENDS ALLOW FOR POSITIVE, ACCURATE ADJUSTMENT



**PART**

**#PMM 8-802**

### ENGINE MOUNT RACING ALTERNATOR KIT

- ★ THIS KIT WILL ATTACH TO EITHER SIDE OF THE MOTOR VIA THE TWO BOLTS THAT ATTACH THE WATER PUMP
- ★ A V-BELT PULLEY IS SUPPLIED THAT IS MOUNTED TO THE FRONT OF THE WATER PUMP PULLEY
- ★ IN MOST CASES, THIS DRIVE SYSTEM WILL NOT INTERFERE WITH ANY EXISTING SETUP

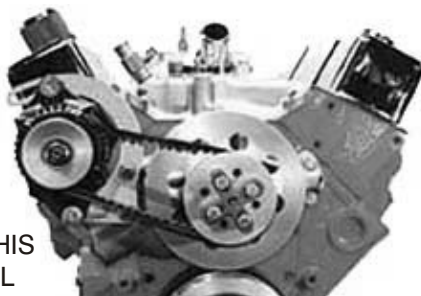

**PART #PMM 8-801**

NOTE: THIS KIT CAN ALSO BE MOUNTED BACKWARDS (DRIVING OFF THE WATER PUMP) IF THE SPACERS ARE CHANGED & A DIFFERENT BELT SIZE IS USED

## RACING ALTERNATOR KITS 100 AMP, HIGH MOUNT RACING ALTERNATOR KIT

- ★ THIS KIT MOUNTS THE ALTERNATOR TO THE PASSENGER SIDE CYLINDER HEAD AREA & DRIVES OFF THE FRONT OF THE WATER PUMP WITH A SERPENTINE PULLEY SYSTEM
- ★ THIS SETUP DOESN'T INTERFERE WITH OTHER BELT DRIVE SYSTEMS ALREADY IN USE
- ★ THE ALTERNATOR PRODUCES 60 AMPS AT LOW RPM & 100 AMPS AT RACING SPEED

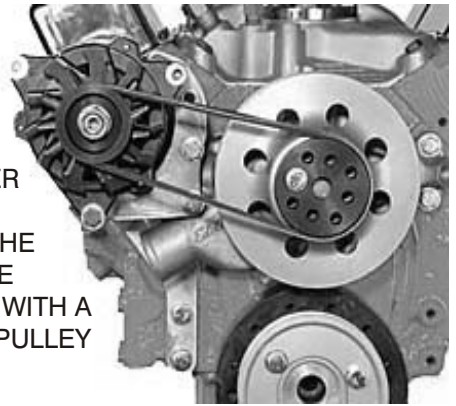

**PART #PMM 8-722**

## DRAG RACING ALTERNATOR KITS

- ★ THESE EASY-TO-INSTALL KITS WILL SOLVE LOW VOLTAGE PROBLEMS
- ★ EACH KIT INCLUDES A ONE WIRE ALTERNATOR (50 OR 100 AMPS) WITH BLACK THERMAL COAT FINISH, HARD-COATED, DEEP-GROOVE ALTERNATOR & CRANK PULLEYS, AND A BRACKET KIT COMPLETE WITH BELT

### LOW MOUNT KITS FOR RAILED CARS

- ★ MOUNTS ON EITHER SIDE OF THE ENGINE



DESCRIPTION	PART #
LOW MOUNT KIT, 50 AMPS, SBC	PMM 8-896
LOW MOUNT KIT, 50 AMPS, BBC	PMM 8-895
LOW MOUNT KIT, 100 AMPS, SBC	PMM 8-898
LOW MOUNT KIT, 100 AMPS, BBC	PMM 8-897

### SNUG MOUNT KITS FOR BODIED CARS

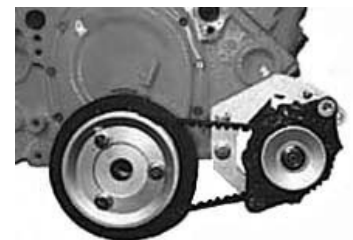

DESCRIPTION	PART #
SNUG MOUNT KIT, 50 AMPS, SBC	PMM 8-875
SNUG MOUNT KIT, 50 AMPS, BBC	PMM 8-880
SNUG MOUNT KIT, 100 AMPS, SBC	PMM 8-881
SNUG MOUNT KIT, 100 AMPS, BBC	PMM 8-882

Place your order at (479) 646-6988, Fax to (479) 646-5939, or visit [www.southwestspeed.com](http://www.southwestspeed.com)



# MINI-STARTERS BLOCK MOUNT

- ★100% BRAND NEW STARTERS, NOT REBUILT
- ★SMALL BLOCK CHEVY STARTERS WILL FIT STANDARD SBC, LT-1, & CRATE BLOCKS
- ★ALSO AVAILABLE FOR LS SERIES



#499-801  
HI-TORQUE, 12 VOLT



#499-797 & #499-799  
CLEARS OIL PANS WHERE STOCK STARTER CLEARS



#499-802  
CLEARS OIL PANS WHERE STOCK STARTER CLEARS;  
CLEARS MOST HEADERS



#499-803  
CLEARS OIL PANS WHERE STOCK STARTER CLEARS;  
CLEARS MOST HEADERS

BLOCK	FLYWHEEL (TEETH)	FT. LBS. TORQUE	LBS.	PART #
SBC	153 & 168	165	10.5	499-801
SBC	153 & 168	170	10.5	499-797
SBC	153 & 168	180	10.5	499-799
SBC	153	200	8.0	499-802
SBC	168	200	8.0	499-803
SBC LS SERIES	168	200	8.0	499-804

## REVERSE MOUNT FOR BRINN, BERT, & FALCON BELLHOUSINGS

- ★100% BRAND NEW STARTER, NOT REBUILT
- ★FITS BRINN, BERT, & FALCON BELLHOUSINGS
- ★200 FT. LBS. OF TORQUE
- ★WEIGHS ONLY 8 LBS.



PART #499-811

## QUARTER MASTER REVERSE MOUNT STARTERS

- ★PREMIUM QMI STARTERS TO FIT QMI BELLHOUSINGS
- ★DRAW APPROXIMATELY 210 AMPS AT A RATED LOAD
- ★NOT AFFECTED BY NORMAL UNDER HOOD OPERATING TEMPERATURES



DESCRIPTION	PART #
QMI STARTER TO WORK W/ ALL QMI BELLHOUSINGS USING A QMI CLUTCH	QMI 114-260
QMI STARTER TO WORK W/ #110-115 QMI BERT/BRINN BELLHOUSING ONLY	QMI 114-267

# MINI-STARTERS REPAIR PARTS



#499-896 SHOWN

#390-080  
SHOWN



DESCRIPTION	PART #
PINION HOUSING & SOLENOID MOUNT FOR #499-801	499-875
CLUTCH ASSY. W/ PINION (499-801)	499-885
PINION GEAR (499-801 STARTER)	499-890
PINION GEAR, 9T, REVERSE BRINN/BERT	499-891
PINION GEAR, 9T, REVERSE QMI, TILTON	499-894
PINION GEAR, 11T, MAX STARTER	499-892
PINION GEAR, 13T, REVERSE TILTON	499-896
SOLENOID	499-880
REMOTE SOLENOID, 12 VOLT, 4 TERMINAL	390-080

## MOUNTING BLOCK

- ★REPAIR OR REPLACE BLOCK MOUNT PLATE



- ★FITS #499-801 STARTER
- ★LIGHTWEIGHT ALUMINUM

PART #499-870

## STARTER SHIMS

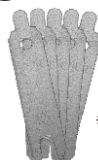

#499-851  
SHOWN

- ★ADJUSTS YOUR STARTER TO FIT THE FLYWHEEL AT JUST THE RIGHT DEPTH
- ★AVAILABLE FOR SBC BLOCK MOUNT & BERT/BRINN

DESCRIPTION	PART #
CHEVY STARTER SHIMS, 5 PACK	499-851
BERT/BRINN SHIMS .030", SOLD EACH	650-175

## QUICK RELEASE WIRING HARNESS

- ★2 WIRE QUICK RELEASE FOR QUICKER MOTOR CHANGES & EASY WIRING INSTALLATION
- ★FITS #499-801 STARTER



PART #499-846

## HEAT SHIELD

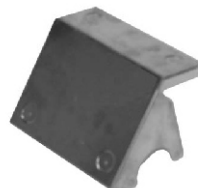

- ★FITS #499-801 STARTER
- ★DOUBLE WALL ALUMINUM HEAT SHIELD PROTECTS STARTER FROM HEADER HEAT

PART #499-848

## STARTER BOLT KITS

- ★AVAILABLE TO BOLT STARTERS ON SBC BLOCK AND BRINN, BERT, & FALCON BELLHOUSINGS
- ★COME W/ 2 BOLTS & 2 LOCK WASHERS



DESCRIPTION	PART #
KIT FOR SBC BLOCKS	499-8504
KIT FOR BRINN BELLHOUSINGS	499-8505
KIT FOR BERT & FALCON BELLHOUSINGS	499-8506

Place your order at (479) 646-6988, Fax to (479) 646-5939, or visit [www.southwestspeed.com](http://www.southwestspeed.com)

# STOCK-TYPE CLUTCHES SBC FLYWHEELS

- ★ FLYWHEELS FOR "STOCK CLUTCH RULE" CLASSES
- ★ STEEL & ALUMINUM
- ★ 10 1/2", 153 TEETH & 11", 168 TEETH FOR SBC'S



DESCRIPTION	LB.	PART #
PRE-86, STEEL, 10.5", 153 T	10.0	RAM 1510-10
PRE-86, STEEL, 10.5", 153 T	12.0	RAM 1510-12
PRE-86, STEEL, 10.5", 153 T	16.0	RAM 1510
PRE-86, STEEL, 10.5", 153 T	19.3	650-01510
PRE-86, STEEL, 11", 168 T	33.0	RAM 1501
PRE-86, STEEL, 11", 168 T	27.3	650-01501
PRE-86, ALUM., 10.5", 153 T	12.6	RAM 2511
PRE-86, ALUM., 11", 168 T	14.4	RAM 2501
86-UP, STEEL, EXT. BAL., 10.5"	10.0	RAM 1512-10
86-UP, STEEL, EXT. BAL., 10.5"	12.0	RAM 1512-12
86-UP, STEEL, EXT. BAL., 10.5"	16.0	RAM 1512
86-UP, STEEL, "0" BAL., 10.5"	10.0	RAM 1514-10
86-UP, STEEL, "0" BAL., 10.5"	12.0	RAM 1514-12
86-UP, STEEL, "0" BAL., 10.5"	16.0	RAM 1514
86-UP, STEEL, EXT. BAL., 11"	33.0	RAM 1530
86-UP, ALUM., EXT. BAL., 11"	18.0	RAM 2530
LS1/LS6, STEEL, 11", 168 T	25.0	RAM 1550
LS1/LS6, STEEL, 11", 168 T	29.0	650-01550
LS1/LS6, ALUM., 11", 168 T	18.0	RAM 2550

# BBC, FORD, HOLDEN FLYWHEELS

DESCRIPTION	PART #
BBC, STEEL, 10.5", 153 TOOTH	PCE 2506
BBC, STEEL, 11", 168 TOOTH	PCE 2507
FORD 289,302,351W, STEEL, 28 OZ,157T	PCE 2508
FORD 289,302,351W, STEEL, 28 OZ,157T	RAM 1527
FORD 289,302,351W, ALUM., 28 OZ,157T	RAM 2527
FORD 289,302,351W, STEEL, 50 OZ,157T	PCE 2509
FORD 289,302,351W, STEEL, 50 OZ,157T	RAM 1525
FORD 289,302,351W, ALUM., 50 OZ,157T	RAM 2525
FORD 289,302,351W, STEEL, "0" BAL,157	RAM 1529
FORD 289,302,351W, ALUM., "0" BAL,157	RAM 2529
FORD 351C, STEEL, 163 TOOTH	PCE 2510
BB FORD 460, STEEL, 163 TOOTH	PCE 2511
BB FORD 460, STEEL, 184 TOOTH	PCE 2512
FORD 2000/2300, STEEL, 135 TOOTH	RAM 1535
HOLDEN 253/308, STEEL, 153 TOOTH	PCE 2513

# BALANCER COUNTER WEIGHT PLATE

- ★ PLATED FOR LONG LIFE
- ★ BOLTS TO 400 CHEVY CRANK
- ★ ELIMINATES THE NEED FOR A BALANCED FLYWHEEL
- ★ MODIFICATION REQUIRED IF USED WITH RING GEAR UNDER 10 1/2" DIAMETER

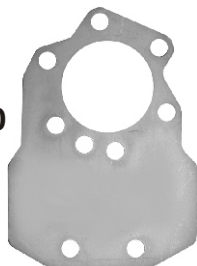

# STOCK-TYPE CLUTCHES PRESSURE PLATES

- ★ 10 1/2" LIGHTWEIGHT STEEL, STANDARD WEIGHT STEEL, & ALUMINUM AVAILABLE
- ★ 8 1/2" & 11" STEEL ONLY
- ★ DIAPHRAGM TYPE
- ★ FITS MOST STOCK CLASSES



DESCRIPTION	LB.	PART #
SBC, STEEL, 10.5"	11.7	RAM 851
SBC, STEEL, 10.5"	13.7	RAM 400
SBC, STEEL, 10.5"	16.9	RAM 401
SBC, STEEL, 11"	19.3	RAM 402
SBC, ALUMINUM, 10.5"	13.3	RAM 801
FORD, STEEL, 10.5"	18.0	RAM 434
FORD 2000/2300, STEEL, 8.5"	10.0	RAM 40315

# 6 PADDLE CLUTCH DISCS

- ★ 8 1/2", 10 1/2" & 11" DIAMETER AVAILABLE
- ★ FITS MOST STOCK CLASSES
- ★ SOLID CENTERS

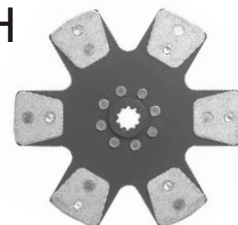

DESCRIPTION	LB.	PART #
SBC, 6 PAD, 10.5", 1 1/8"-10	3.0	RAM 1021
SBC, 6 PAD, 10.5", 1 5/32"-26	3.0	RAM 1029
SBC, 6 PAD, 11", 1 1/8"-10	3.0	RAM 1122
FORD, 6 PAD, 10.5", 1 1/16"-10	3.0	RAM 1025
FORD, 6 PAD, 8.5", 1 1/16"-10	2.0	RAM 1015
FORD, 6 PAD, 8.5", 1"-23	2.0	RAM 1016

# ORGANIC ROUND CLUTCH DISCS

- ★ FLAT CARRIER FOR QUICKER, CLEANER DISENGAGEMENT IN SHIFTING
- ★ SOLID CENTERS & SPRUNG CENTERS AVAILABLE

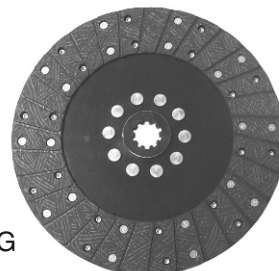

SOLID CENTER DISCS	LB.	PART #
SBC, ROUND, 10.5", 1 1/8"-10	2.5	RAM 251
SBC, ROUND, 10.5", 1 5/32"-26	2.5	RAM 259
FORD, 10.5", 1 1/16"-10	2.5	RAM 255
SPRUNG CENTER DISCS	LB.	PART #
SBC, ROUND, 10.5", 1 1/8"-10	5.3	RAM 301M
SBC, ROUND, 10.5", 1 5/32"-26	5.3	RAM 309M
FORD, 10.5", 1 1/16"-10	5.3	RAM 305M

# HARMONIC BALANCERS

- ★ RACING FLUID DAMPERS, RACING STEEL ELASTIC DAMPERS, & STREET STEEL ELASTIC DAMPERS ARE AVAILABLE FOR SBC, BBC, SBF, BBF, CHRYSLER, PONTIAC, OLDSMOBILE, ETC.
- ★ SEE PAGE 97



Place your order at (479) 646-6988, Fax to (479) 646-5939, or visit [www.southwestspeed.com](http://www.southwestspeed.com)



# DELUXE STOCK-TYPE CLUTCH KITS

★AVAILABLE FOR PRE-86 AND 1986 & NEWER MOTORS

★SBC DELUXE STOCK CLUTCH KITS INCLUDE:

- \*PRESSURE PLATE, 10.5"
- \*CLUTCH DISC, 10.5" (EITHER FULL ORGANIC OR 6 PADDLE AND EITHER 1 1/8"-10 OR 1 5/32"-26 SPLINE)
- \*FLYWHEEL, 10.5", 153 TOOTH
- \*LIGHTWEIGHT BELLHOUSING
- \*STOCK HYDRAULIC THROWOUT BEARING

- \*LONG PILOT BUSHING
- \*FLYWHEEL BOLT KIT &
- \*PRESSURE PLATE BOLT KIT



DESCRIPTION		PART NUMBERS	
MODEL	SPLINE	ORGANIC DISC	6 PADDLE DISC
DELUXE PRE-86 KIT	1 1/8"-10	RAM 900000	RAM 900006
DELUXE PRE-86 KIT	1 5/32"-26	RAM 900010	RAM 900016
DELUXE 1986-UP KIT	1 1/8"-10	RAM 900020	RAM 900026
DELUXE 1986-UP KIT	1 5/32"-26	RAM 900030	RAM 900036

# COMPLETE STOCK-TYPE CLUTCHES

★SBC STOCK-TYPE CLUTCHES INCLUDE:

- \*PRESSURE PLATE, 10.5"
- \*FLYWHEEL, 10.5", 153 TOOTH &
- \*CLUTCH DISC, 10.5" (EITHER FULL ORGANIC OR 6 PADDLE AND EITHER 1 1/8"-10 OR 1 5/32"-26 SPLINE)
- \*FLYWHEEL BOLT KIT & PRESSURE PLATE BOLT KIT



DESCRIPTION			PART NUMBERS (TOTAL KIT WEIGHT)		
MODEL	SPLINE	DISC	37 LB.	27 LB.	25 LB.
PRE-86	1 1/8"-10	ORG.	RAM 900080	RAM 900100	RAM 910100
PRE-86	1 1/8"-10	6 PAD.	RAM 900086	RAM 900106	RAM 910106
PRE-86	1 5/32"-26	ORG.	RAM 900180	RAM 900200	RAM 910200
PRE-86	1 5/32"-26	6 PAD.	RAM 900186	RAM 900206	RAM 910206
1986-UP	1 1/8"-10	ORG.	RAM 900280	RAM 900300	RAM 910300
1986-UP	1 1/8"-10	6 PAD.	RAM 900286	RAM 900306	RAM 910306
1986-UP	1 5/32"-26	ORG.	RAM 900380	RAM 900400	RAM 910400
1986-UP	1 5/32"-26	6 PAD.	RAM 900386	RAM 900406	RAM 910406

PRESSURE PLATE & CLUTCH DISC SETS ONLY					
MODEL	SPLINE	DISC	19.5 LB.	16 LB.	14 LB.
BOTH	1 1/8"-10	ORG.	RAM 900117	RAM 900125	RAM 900137
BOTH	1 1/8"-10	6 PAD.	RAM 900117-6	RAM 900126	RAM 900137-6
BOTH	1 5/32"-26	ORG.	RAM 900118	RAM 900130	RAM 900138
BOTH	1 5/32"-26	6 PAD.	RAM 900118-6	RAM 900136	RAM 900138-6

# FLEXPLATES RACING-TYPE

★RACING QUALITY; STRONG, DURABLE, FABRICATED STEEL CONSTRUCTION

★CHEVY & FORD AVAILABLE

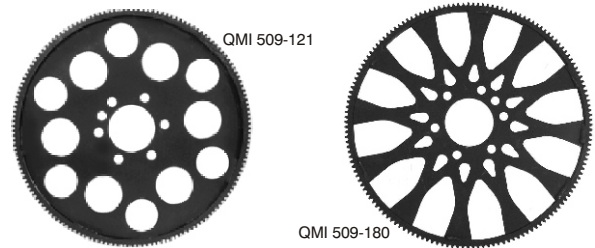

DESCRIPTION	WEIGHT	PART #
CHEVY, 153 TOOTH	4.0	QMI 509-121
CHEVY, 153 TOOTH, LW	2.9	QMI 509-180
FORD, 157 TOOTH	4.8	QMI 509-322

# STOCK-TYPE

★AVAILABLE FOR PRE-86 AND 1986 & NEWER MOTORS; 153 TOOTH OR 168 TOOTH

★BALANCED, DOUBLE WELDED & BUILT FOR STRESS

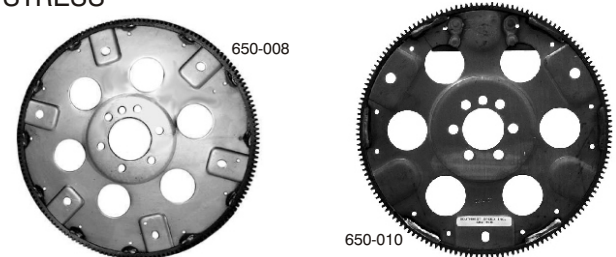

DESCRIPTION	WEIGHT	PART #
PRE-86 CHEVY, 153 TOOTH	4.3	650-008
PRE-86 CHEVY, 168 TOOTH	4.5	650-009
86-UP CHEVY, 153 TOOTH	5.5	650-010

# FLYWHEEL, FLEXPLATE, & COUPLER BOLT KITS

- ★HIGH STRENGTH 12 POINT BOLTS
- ★SOLD IN SETS OF 6
- ★3 DIFFERENT SETS AVAILABLE



- ★650-0017: 7/16"-20 x 7/8"
- ★650-001 : 7/16"-20 x 1"
- ★650-048 : 7/16"-20 x 1 1/4"

APPLICATION	USE #
BRINN BELLHOUSING KIT WITH BRINN FLYWHEEL	650-001
BRINN DIRECT DRIVE COUPLER WITH FLEXPLATE	650-048
BERT BELLHOUSING KIT WITH BERT FLYWHEEL	650-048
BERT DIRECT DRIVE COUPLER WITH FLEXPLATE	650-001
FALCON BELLHOUSING KIT W/ FALCON FLYWHEEL	650-0017
FALCON DIRECT DRIVE COUPLER WITH FLEXPLATE	650-0017
QUARTERMASTER, RAM, TILTON, ETC.	650-0017
MINI-CLUTCH WITH FLEXPLATE	
STOCK-TYPE STEEL FLYWHEEL	650-0017

NOTE: FOR A CONSTANT STREAM OF NEW PRODUCTS & UP-TO-THE-SECOND PRICING, VISIT [WWW.SOUTHWESTSPEED.COM](http://WWW.SOUTHWESTSPEED.COM)

Place your order at (479) 646-6988, Fax to (479) 646-5939, or visit [www.southwestspeed.com](http://www.southwestspeed.com)



# FLYWHEEL/FLEXPLATE SHIMS

- ★ SPACES FLYWHEEL FROM CRANK FOR PROPER STARTER ALIGNMENT
- ★ FORD OR CHEVY
- ★ STACKABLE

CHEVY SHIM SHOWN

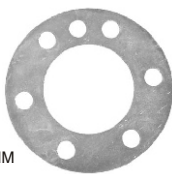

DESCRIPTION	PART #
CHEVY FLYWHEEL SHIM, .030" THICK	650-177
CHEVY FLYWHEEL SHIM, .035" THICK	650-1771
CHEVY FLYWHEEL SHIM, .046" THICK	650-1772
CHEVY FLYWHEEL SHIM, .057" THICK	650-1773
CHEVY FLYWHEEL SHIM, .072" THICK	650-1774
86&UP CHEVY FLY. SHIM, .030" THICK	650-1776
FORD FLYWHEEL SHIM, .030" THICK	650-176

# SAFETY SHIELD

- ★ 1/8" PLATED STEEL
- ★ BOLTS TO ANY CHEVY AUTOMATIC TRANSMISSION
- ★ DESIGNED TO DEFLECT RING GEARS



PART #650-025

# RAM COUPLERS

- ★ POSITIVE LOCK UP
- ★ LIGHTWEIGHT
- ★ REPAIRABLE
- ★ USES FLEXPLATE
- ★ UNIQUE CONE DESIGN

CHEVY SHOWN

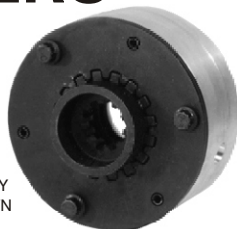

DESCRIPTION	PART #
COUPLER - 1 1/8"-10 SPLINE, CHEVY	RAM 28510
COUPLER - 1 1/16"-10 SPLINE, FORD	RAM 28545
COUPLER - 1"-23 SPLINE, 2300 PINTO	RAM 28561
COVER PLATE ONLY	RAM 28513
CONE ASSY. ONLY - 1 1/8"-10 SPLINE	RAM 28519
REPLACEMENT LINING ONLY	RAM 28524
REPLACEMENT BEARING WASHER KIT	RAM 28528
ENGAGEMENT SPRING	RAM 28537
SPRING WASHER	RAM 28581
THROWOUT BEARING	RAM 488

# RAM CLUTCH ALIGNMENT SHAFTS

- ★ ALIGNS CLUTCH DISCS FOR EASY INSTALLATION OF THE TRANSMISSION
- ★ DURABLE NON-CORROSIVE PLASTIC
- ★ 3 POPULAR SPLINES AVAILABLE



DESCRIPTION	PART #
ALIGNMENT SHAFT, 1 1/8"-10 SPLINE	RAM 5301
ALIGNMENT SHAFT, 1 1/16"-10 SPLINE	RAM 5304
ALIGNMENT SHAFT, 1 5/32"-26 SPLINE	RAM 5313

# RAM MINI-CLUTCHES

- ★ ASSAULT WEAPON, BUTTON TYPE MINI-CLUTCHES
- ★ 3 DISC CLUTCHES WEIGH ONLY 11.9 LBS
- ★ 6 1/4" IN DIAMETER
- ★ OPEN DESIGN
- ★ TRI-PADDLE DISC



DESCRIPTION	PART #
3 DISC, 1 1/8"-10, CHEVY, PRE-86	RAM 9351S
3 DISC, 1 5/32"-26, CHEVY, PRE-86	RAM 9353S
3 DISC, 1 1/8"-10, CHEVY, 86-UP	RAM 9371S
3 DISC, 1 5/32"-26, CHEVY, 86-UP	RAM 9373S
3 DISC, 1 1/16"-10, FORD	RAM 9355S
3 DISC, 1 5/32"-26, FORD	RAM 9357S
3 DISC, 1"-23, FORD 2000/2300 PINTO	RAM 9330

# RAM ASSAULT WEAPON MINI-CLUTCH PARTS



RAM 9901

RAM 9902

RAM 9903

- ★ PARTS FIT ASSAULT WEAPON CLUTCHES ONLY

DESCRIPTION	PART #
FLOATER PLATE	RAM 9901
PRESSURE PLATE	RAM 9902
DIAPHRAGM COVER	RAM 9903
3 DISC ASSAULT STUD & NUT SET	RAM 9029
ASSAULT CLEARANCE SHIM KIT	RAM 9920
SBC THROWOUT BEARING, 3 DISC	RAM 495
FLYWHEEL BOLT KIT ONLY	650-0017

# RAM CLUTCH DISCS

- ★ SINGLE DISC, DOUBLE DISC, & TRIPLE DISC PACKS AVAILABLE FOR FORD & CHEVY
- ★ FITS RAM ASSAULT CLUTCHES ONLY

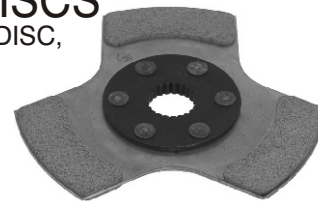

DESCRIPTION	PART #
1 1/8"-10 SPLINE, 1 DISC	RAM 9951
1 1/8"-10 SPLINE, 2 DISC	RAM 9951-2
1 1/8"-10 SPLINE, 3 DISC	RAM 9951-3
1 5/32"-26 SPLINE, 1 DISC	RAM 9953
1 5/32"-26 SPLINE, 2 DISC	RAM 9953-2
1 5/32"-26 SPLINE, 3 DISC	RAM 9953-3
1 1/16"-10 SPLINE, 1 DISC	RAM 9955
1 1/16"-10 SPLINE, 2 DISC	RAM 9955-2
1 1/16"-10 SPLINE, 3 DISC	RAM 9955-3

Place your order at (479) 646-6988, Fax to (479) 646-5939, or visit [www.southwestspeed.com](http://www.southwestspeed.com)

# QUARTER MASTER MINI-CLUTCHES

## 5 1/2" PRO SERIES GEAR DRIVE

- ★BUTTON-TYPE MINI-CLUTCHES
- ★CLOSED DESIGN
- ★3 DISC CHEVY & FORD AVAILABLE
- ★5 1/2" ROUND DISCS



DESCRIPTION	PART #
3 DISC, 1 1/8"-10 BUTTON, SBC	QMI 395-17080
3 DISC, 1 5/32"-26 BUTTON, SBC	QMI 395-17090
3 DISC, 1 1/16"-10 BUTTON, SBF	QMI 395-30270
3 DISC, 1 1/8"-10 BUTTON, SBF	QMI 395-30280
FLYWHEEL BOLT KIT ONLY	650-0017

## 7 1/4" V-DRIVE

- ★BUTTON TYPE
- ★LIGHTWEIGHT, OPEN DESIGN
- ★2 & 3 DISC AVAILABLE
- ★7 1/4" ROUND DISCS



DESCRIPTION	PART #
2 DISC, 1 1/8"-10, CHEVY, PRE-86	QMI 298-108
2 DISC, 1 1/8"-10, CHEVY, 86-UP	QMI 298-103
3 DISC, 1 1/8"-10, CHEVY, PRE-86	QMI 398-108
3 DISC, 1 1/8"-10, CHEVY, 86-UP	QMI 398-103
3 DISC, 1 5/32"-26, CHEVY, PRE-86	QMI 398-158
3 DISC, 1 5/32"-26, CHEVY, 86-UP	QMI 398-153
3 DISC, 1 1/16"-10, FORD	QMI 398-318
3 DISC, 1 5/32"-26, FORD	QMI 398-358
FLYWHEEL BOLT KIT ONLY	650-0017

## QMI CLUTCH DISCS

- ★5 1/2" & 7 1/4" DIAMETER IN ALL POPULAR SPLINES
- ★RECOMMENDED TO CHANGE DISCS WHEN THICKNESS IS BELOW .090" ON 2 DISC OR .094" ON 3 DISC

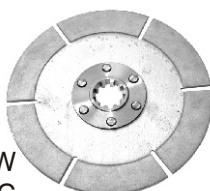

DESCRIPTION	PART #
5 1/2" DIA., 1 1/8"-10, 2 DISC	QMI 225-080
5 1/2" DIA., 1 1/8"-10, 3 DISC	QMI 325-080
5 1/2" DIA., 1 5/32"-26, 2 DISC	QMI 225-090
5 1/2" DIA., 1 5/32"-26, 3 DISC	QMI 325-090
5 1/2" DIA., 1 1/16"-10, 2 DISC	QMI 225-070
5 1/2" DIA., 1 1/16"-10, 3 DISC	QMI 325-070
5 1/2" DIA., 1"-23 FORD, 2 DISC	QMI 225-063
5 1/2" DIA., 1"-23 FORD, 3 DISC	QMI 325-063
7 1/4" DIA., 1 1/8"-10, 2 DISC	QMI 226-080
7 1/4" DIA., 1 1/8"-10, 3 DISC	QMI 309-390
7 1/4" DIA., 1 5/32"-26, 2 DISC	QMI 226-090
7 1/4" DIA., 1 5/32"-26, 3 DISC	QMI 309-395
7 1/4" DIA., 1 1/16"-10, 2 DISC	QMI 226-070
7 1/4" DIA., 1 1/16"-10, 3 DISC	QMI 309-391
7 1/4" DIA., 1 3/8"-10, 2 DISC	QMI 226-099
7 1/4" DIA., 1 3/8"-10, 3 DISC	QMI 309-392
7 1/4" DIA., 1"-23 FORD, 2 DISC	QMI 226-063
7 1/4" DIA., 1"-23 CHRYSLER, 2 DISC	QMI 226-093

# QUARTER MASTER 5 1/2" GEAR DRIVE CLUTCH KITS - SBC

- ★COMPLETE SBC CLUTCH KITS INCLUDE:
  - \*3 DISC, 5 1/2" GEAR DRIVE MINI-CLUTCH
  - \*LIGHTWEIGHT ALUMINUM BELLHOUSING
  - \*REVERSE MOUNT STARTER
  - \*STARTER RING GEAR
  - \*HYDRAULIC THROWOUT BEARING
  - \*BLEEDER LINE KIT
- ★1 1/8"-10 & 1 5/32"-26 SPLINE KITS AVAILABLE



DESCRIPTION	PART #
COMPLETE CLUTCH KIT, 1 1/8"-10	QMI 110-39580
COMPLETE CLUTCH KIT, 1 5/32"-26	QMI 110-39590

## MINI-CLUTCH PARTS



DESCRIPTION	PART #
DIAPHRAGM COVER, STEEL, 5 1/2"	QMI 105-500
CLUTCH HOUSING, 5 1/2", 2 DISC	QMI 205-503
CLUTCH HOUSING, 5 1/2", 3 DISC	QMI 305-503
PRESSURE PLATE, 5 1/2"	QMI 105-501
FLOATER PLATE, 5 1/2"	QMI 105-506
CLUTCH BOLT KIT, 5 1/2", 3 DISC	QMI 305-508
DIAPHRAGM COVER, 7 1/4", 2 DISC	QMI 208-500
DIAPHRAGM COVER, 7 1/4", 3 DISC	QMI 308-500
PRESSURE PLATE, 7 1/4"	QMI 108-501
FLOATER PLATE, 7 1/4"	QMI 508-506
CLUTCH BOLT KIT, 7 1/4", 3 DISC	QMI 309-507

## RING GEARS

- ★FITS 5 1/2" & 7 1/4" QUARTER MASTER MINI-CLUTCHES
- ★USED WITH REVERSE MOUNTED STARTER



DESCRIPTION	PART #
RING GEAR, 5 1/2", W/O MID PLATE	QMI 310-010
RING GEAR, 5 1/2", WITH MID PLATE	QMI 310-011
RING GEAR, 7 1/4", W/O MID PLATE	QMI 110-010

Place your order at (479) 646-6988, Fax to (479) 646-5939, or visit [www.southwestspeed.com](http://www.southwestspeed.com)

## QUARTER MASTER MINI-FLYWHEELS



DESCRIPTION	PART #
5.5" BUTTON, SBC	QMI 505-170
5.5" BUTTON, SBC 86 & UP	QMI 505-171
5.5" BUTTON, FORD	QMI 505-302
7.25" BUTTON, SBC	QMI 509-110
7.25" BUTTON, SBC 86 & UP	QMI 509-113
7.25" BUTTON, FORD	QMI 509-311
7.25" BUTTON, MOPAR 6 BOLT	QMI 509-211
BERT/BRINN, 110 TOOTH, SBC	QMI 509-124
BERT/BRINN, 91 TOOTH, SBC 86-UP	QMI 509-134B

## STOCK-TYPE HYDRAULIC THROWOUT BEARINGS

### QUARTER MASTER STOCK-TYPE HYDRAULIC BEARINGS

★ FITS STOCK STYLE CLUTCHES & MOST TRANSMISSIONS, INCLUDING SAGINAW, MUNCIE, GM T-10, JERICO, RICHMOND, TREMEC TKO 400/600, & OTHERS

★ COMES COMPLETE WITH SHIMS, INLET LINE, & BLEEDER LINE



**PART #**  
**QMI 721-100**

DESCRIPTION	PART #
QMI STOCK/STREET T.O. BEARING	QMI 721-100
SEAL KIT	QMI 721-101
SHIM KIT	QMI 720-102

## RAM STOCK-TYPE HYD. BEARINGS

★ AVAILABLE FOR SBC & FORD WITH FLAT BEARING FACE FOR STOCK-TYPE CLUTCHES

★ THREADED ADJUSTABLE DESIGN ELIMINATES THE NEED FOR SHIMS

★ LIGHTWEIGHT ALUMINUM HOUSING

★ HARDCOATED PISTON & CYLINDER

★ NECESSARY HARDWARE INCLUDED



DESCRIPTION	PART #
BEARING KIT, CHEVY, FLAT	RAM 48150
BEARING KIT, FORD, FLAT	RAM 48250
O-RING & SHIM KIT	RAM 48500
SNAP RING KIT	RAM 48520

## STOCK-TYPE HYDRAULIC THROWOUT BEARINGS

### SOUTHWEST SPEED STOCK-TYPE HYDRAULIC BEARING

★ FITS STOCK STYLE CLUTCHES

★ WORKS WITH SAGINAW, MUNCIE, GM T-10, & JERICO TRANSMISSIONS, AS WELL AS ANY TRANSMISSION THAT HAS A BEARING RETAINER COLLAR WITH AN OUTSIDE DIAMETER OF 1.375" OR LESS, AS THE INSIDE DIAMETER OF THIS BEARING IS 1.380"

★ WON'T FIT T-5 OR NON-GM T-10 TRANSMISSIONS

★ COMES WITH A SHIM SET & TWO INSTALLATION STUDS (ONE 5/16"-18 & ONE 3/8"-16)



**PART**  
**#650-6210**

DESCRIPTION	PART #
SWS STOCK/STREET T.O. BEARING	650-6210
O-RING KIT	650-6261
BEARING ONLY	650-6281
SHIM KIT	650-6301
5/16"-18 STUD	650-6311
3/8"-16 STUD	650-6321
CLUTCH LINE KIT, 36" LONG	390-013
3/4" CLUTCH MASTER CYLINDER	290-412

## CLUTCH LINE KIT



**PART #390-013**

★ 36" LONG, -4 AN STEEL BRAIDED HOSE

★ 1/8" NPT TO -4 AN FITTING

★ 90° 3/16" LINE TO -4 AN STRAIGHT

★ CONNECTS MASTER CYLINDER TO SLAVE CYLINDER OR HYDRAULIC THROWOUT BEARING

## REMOTE BLEEDER KIT

★ ALLOWS YOU TO BLEED THE BEARING FROM OUTSIDE THE BELLHOUSING

★ 1/8" NPT MALE TO 1/8" NPT FEMALE

★ SCREWS DIRECTLY INTO BLEEDER HOLE

★ 15" LONG



**PART #650-3901**

## HYDRAULIC COUPLER

★ ALLOWS YOU TO REMOVE & REINSTALL THE MOTOR OR THROWOUT BEARING WITHOUT RE-BLEEDING OR LOSING FLUID

★ 1/8"-27 NPT FEMALE

**PART #903-010**



Place your order at (479) 646-6988, Fax to (479) 646-5939, or visit [www.southwestspeed.com](http://www.southwestspeed.com)



# RACING HYDRAULIC THROWOUT BEARINGS

## SOUTHWEST SPEED RACING HYDRAULIC BEARING

- ★WORKS WITH MOST MINI-CLUTCHES INCLUDING RAM, QUARTER MASTER, & TILTON
- ★WON'T WORK WITH STOCK-TYPE CLUTCHES OR RAM COUPLER
- ★WORKS WITH SAGINAW, MUNCIE, GM T-10, & JERICO TRANSMISSIONS, AS WELL AS ANY TRANSMISSION THAT HAS A BEARING RETAINER COLLAR WITH AN OUTSIDE DIAMETER OF 1.395" OR LESS, AS THE INSIDE DIAMETER OF THIS BEARING IS 1.400"
- ★WON'T FIT T-5 OR NON-GM T-10 TRANSMISSIONS
- ★LIGHTWEIGHT ALUMINUM HOUSING
- ★EASILY INSTALLED WITH MOUNTING STUDS, WHICH ARE INCLUDED; NO SHIMS NEEDED



**PART #650-600**

DESCRIPTION	PART #
SWS RACING THROWOUT BEARING	650-600
O-RING KIT	650-606
BEARING & SLEEVE	650-608
5/16"-18 STUD	650-611
3/8"-16 STUD	650-612
SNAP RING	650-615

# QUARTER MASTER RACING HYDRAULIC BEARINGS

- ★FITS QUARTER MASTER RACING MINI-CLUTCHES & MOST TRANSMISSIONS
- ★AVAILABLE FOR 5 1/2" & 7 1/4" CLUTCHES, BOTH STANDARD & LOW GROUND CLEARANCE ASSEMBLIES
- ★ATTACHES DIRECTLY TO THE CLUTCH BALL
- ★COMES WITH INLET FITTING & SHIM ASSORTMENT



DESCRIPTION	PART #
RACE BEARING, 7 1/4" CLUTCH	QMI 710-100
RACE BEARING, 5 1/2" CLUTCH	QMI 710-200
RACE BEARING, 7 1/4" CLUTCH, LGC	QMI 710-300
RACE BEARING, 5 1/2" CLUTCH, LGC	QMI 710-400
SEAL KIT	QMI 710-101
SHIM KIT	QMI 710-102
BEARING & SLEEVE, 7 1/4"	QMI 710-103
BEARING & SLEEVE, 5 1/2"	QMI 710-104
BEARING & SLEEVE, 5 1/2", LGC	QMI 710-107
REPLACEMENT SPRING ONLY	QMI 710-004
BLEEDER SCREW ONLY	QMI 710-011
BLEEDER LINE EXTENSION KIT	QMI 710-105

# RACING HYDRAULIC THROWOUT BEARINGS

## RAM RACING HYDRAULIC BEARINGS

- ★AVAILABLE FOR SBC & FORD WITH ROUND BEARING FACE FOR RACING MINI-CLUTCHES
- ★THREADED ADJUSTABLE DESIGN ELIMINATES THE NEED FOR SHIMS
- ★LIGHTWEIGHT ALUMINUM HOUSING
- ★HARDCOATED PISTON & CYLINDER
- ★NECESSARY HARDWARE INCLUDED



DESCRIPTION	PART #
BEARING KIT, CHEVY, ROUND	RAM 48100
BEARING KIT, FORD, ROUND	RAM 48200
REPLACEMENT BEARING, ROUND	RAM 48010
O-RING & SHIM KIT	RAM 48500
SNAP RING KIT	RAM 48520

# MECHANICAL THROWOUT BEARINGS

- ★FOR MECHANICAL CLUTCH LINKAGES
- ★QMI BEARINGS FIT 3 DISC, 7 1/4" QUARTER MASTER MINI-CLUTCHES
- ★#QMI 309-330C FITS FORD MOTOR WITH CHEVY TRANSMISSION
- ★#RAM 488 FITS RAM COUPLER CLUTCHES, SUCH AS #RAM 28510
- ★#RAM 495 FITS 3 DISC SBC RAM ASSAULT WEAPON MINI-CLUTCHES



RAM 488 SHOWN



QMI 309-130 SHOWN

DESCRIPTION	PART #
3 DISC, BUTTON, CHEVY, 1.900"	QMI 309-130
3 DISC, BUTTON, FORD, 1.0625"	QMI 309-330
3 DISC, BUTTON, FORD, SBC ID	QMI 309-330C
THROWOUT BEARING, COUPLER	RAM 488
THROWOUT BEARING, 3 DISC, SBC	RAM 495

# CLUTCH FORK

- ★STAMPED STEEL CONSTRUCTION
- ★HOLDS CHEVY MECHANICAL THROWOUT BEARING



**PART #650-403**

# CLUTCH BALL



- ★SCREWS IN BELLHOUSING
- ★1 3/4" LONG (END TO END)

**PART #650-402**

NOTE: FOR A CONSTANT STREAM OF NEW PRODUCTS & UP-TO-THE-SECOND PRICING, VISIT [WWW.SOUTHWESTSPEED.COM](http://WWW.SOUTHWESTSPEED.COM)

Place your order at (479) 646-6988, Fax to (479) 646-5939, or visit [www.southwestspeed.com](http://www.southwestspeed.com)

# BELLHOUSINGS

## CHEVY LIGHTWEIGHT - 270°

- ★LIGHTWEIGHT STEEL CONSTRUCTION
- ★WEIGHS ONLY 17.5 LBS.
- ★WORKS WITH ALL GM TRANSMISSIONS WITH A 4.675" O.D. BEARING RETAINER
- ★CONTAINS CLUTCH FAILURE
- ★MEETS SAFETY REQUIREMENT RULES IN MOST CLASSES
- ★WILL FIT 153 & 168 TOOTH FLYWHEELS
- ★USE WITH BLOCK MOUNTED STARTER



**PART #650-400**

## CHEVY LIGHTWEIGHT - 360°

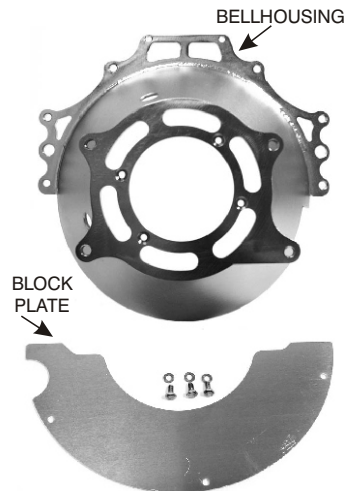

- ★FABRICATED STEEL CONSTRUCTION
- ★WEIGHS ONLY 18 LBS.
- ★WORKS WITH ALL GM TRANSMISSIONS WITH A 4.675" O.D. BEARING RETAINER
- ★CONTAINS CLUTCH FAILURE
- ★COMES WITH DUST COVER & BOLTS
- ★USE WITH BLOCK MOUNTED STARTER & HYDRAULIC THROWOUT BEARING

**PART #650-399**

## FORD STEEL

- ★WORKS WITH FORD TRANSMISSIONS
- ★CONTAINS CLUTCH FAILURE
- ★USE WITH BLOCK MOUNTED STARTER
- ★MEETS SAFETY REQUIREMENT RULES IN MOST CLASSES
- ★COMES WITH BLOCK PLATE, BOLT KIT, & INSTRUCTIONS

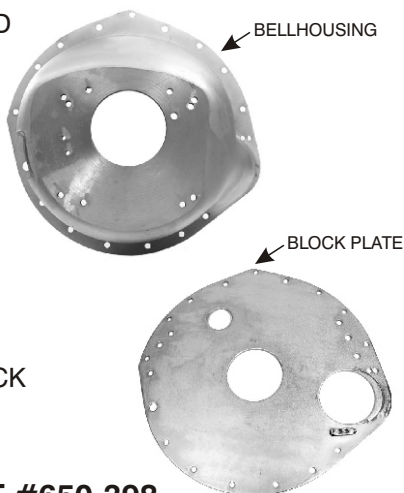

**PART #650-398**

# QUARTER MASTER ALUMINUM BELLHOUSINGS

- ★CNC MACHINED FOR PERFECT FIT
- ★LIGHTWEIGHT ALUMINUM CONSTRUCTION



#QMI 110-104  
PERFECT FIT FOR  
153 TOOTH FLYWHEEL



#QMI 110-102  
LOW GROUND CLEARANCE  
BELLHOUSING; ACCEPTS  
105 TOOTH FLYWHEEL



#QMI 110-100  
LOW GROUND CLEARANCE  
BELLHOUSING; ACCEPTS 105  
TOOTH FLYWHEEL; USE #114-260  
REVERSE MOUNT STARTER



#QMI 110-300  
FOR FORD MOTORS & FORD  
TRANSMISSIONS; USE #114-260  
REVERSE MOUNT STARTER

MOTOR/TRANS	STARTER	WEIGHT	PART #
SBC/GM	BLOCK	10.0	QMI 110-104
SBC/GM, LGC	BLOCK	11.7	QMI 110-102
SBC/GM, LGC	REVERSE	10.9	QMI 110-100
FORD/FORD	REVERSE	11.3	QMI 110-300

# QUARTER MASTER LIGHTWEIGHT STEEL FORD/CHEVY BELLHOUSING

- ★VERSATILE BELLHOUSING WILL FIT FORD & CHEVY MOTORS & GM TRANSMISSIONS
- ★LIGHTWEIGHT FABRICATED STEEL CONSTRUCTION
- ★WEIGHS ONLY 19.6 LBS.
- ★USES 153T CHEVY OR 157T FORD FLYWHEEL
- ★USES BLOCK MOUNT STARTERS



**PART #  
QMI 110-430**

Place your order at (479) 646-6988, Fax to (479) 646-5939, or visit [www.southwestspeed.com](http://www.southwestspeed.com)

# QUARTER MASTER BERT/BRINN BELLHOUSING & STARTER SETUP

- ★LIGHTWEIGHT BELLHOUSING MOUNTS BERT & BRINN TRANSMISSIONS TO SBC'S
- ★AVAILABLE WITH ALUMINUM OR MAGNESIUM BELLHOUSING
- ★REVERSE MOUNT BELLHOUSING FEATURES AN OPENING TO RUN BELT DRIVE PUMP & THE ABILITY TO MOUNT THE PUMP TO THE TOP WITH AN ADD-ON BRACKET
- ★COMPLETE KIT INCLUDES BELLHOUSING, REVERSE MOUNT STARTER, STARTER MOUNTING ADAPTER KIT, DRY SUMP PUMP TOP MOUNT KIT, SMALL BLOCK CHEVY CRANK HUB (COUPLER & 22 TOOTH HTD DRIVE), 91 TOOTH FLYWHEEL, & FLYWHEEL BOLT KIT



DESCRIPTION	PART #
KIT W/ALUMINUM BELLHOUSING	QMI 120509124TM
KIT W/MAGNESIUM BELL.	QMI 115509124TM
REVERSE MOUNT STARTER	QMI 114-267
91 TOOTH RACING FLYWHEEL	QMI 509-124B
FLYWHEEL BOLT KIT, 6 PIECE	650-048

# FLYWHEEL, FLEXPLATE, & COUPLER BOLT KITS

- ★HIGH STRENGTH 12 POINT BOLTS
- ★SOLD IN SETS OF 6
- ★3 DIFFERENT SETS AVAILABLE
- ★650-0017: 7/16"-20 x 7/8"
- ★650-001 : 7/16"-20 x 1"
- ★650-048 : 7/16"-20 x 1 1/4"



APPLICATION	USE #
BRINN BELLHOUSING KIT WITH BRINN FLYWHEEL	650-001
BRINN DIRECT DRIVE COUPLER WITH FLEXPLATE	650-048
BERT BELLHOUSING KIT WITH BERT FLYWHEEL	650-048
BERT DIRECT DRIVE COUPLER WITH FLEXPLATE	650-001
FALCON BELLHOUSING KIT W/ FALCON FLYWHEEL	650-0017
FALCON DIRECT DRIVE COUPLER WITH FLEXPLATE	650-0017
QUARTERMASTER, RAM, TILTON, ETC.	650-0017
MINI-CLUTCH WITH FLEXPLATE	650-0017
STOCK-TYPE STEEL FLYWHEEL	650-0017

# BRINN MAGNESIUM BELLHOUSINGS

- ★BRINN MAGNESIUM BELLHOUSINGS WILL WORK WITH BRINN & BERT TRANSMISSIONS
- ★BELLHOUSING ASSEMBLIES INCLUDE IDLER GEAR ASSEMBLY & 1 PIECE FLYWHEEL (RING GEAR & HTD REAR BELT DRIVE COUPLER IN ONE)
- ★FLYWHEELS ARE AVAILABLE WITH STEEL & ALUMINUM DRIVE COUPLERS
- ★USE W/ REVERSE MOUNT STARTERS, SUCH AS #499-811
- ★AVAILABLE FOR SBC, SBC 86 & UP, CHEVY CRATE (WHICH HAVE EXTERNALLY BALANCED FLYWHEELS), & FORD



DESCRIPTION	PART #
BELLHOUSING, CHEVY, STEEL FLYWHEEL	650-350
BELLHOUSING, CHEVY, ALUM. FLYWHEEL	650-352
BELLHOUSING, CHEVY 86&UP, STEEL FLY.	650-3525
BELLHOUSING, CHEVY CRATE, STEEL FLY	650-353
BELLHOUSING, FORD, STEEL FLYWHEEL	650-360
BELLHOUSING, CHEVY, NO FLYWHEEL	650-3501
BELLHOUSING, CHEVY, BARE	650-3502
BELLHOUSING, FORD, NO FLYWHEEL	650-3601
BELLHOUSING, FORD, BARE	650-3602
SBC, STEEL COUPLER W/ RING GEAR	650-183
SBC, ALUM. COUPLER W/ RING GEAR	650-184
SBC 86 & UP, STEEL COUPLER W/ RING	650-185
SBC CRATE, STEEL COUPLER W/ RING	650-187
SBF, STEEL COUPLER W/ RING GEAR	650-186
BELT RETAINER & SCREWS	650-164
BELT RETAINER SCREW KIT, 4 PIECES	650-1641
IDLER GEAR SPRING ONLY	650-375
IDLER SHAFT PLATE ASSEMBLY	650-376
IDLER SHAFT PLATE ONLY	650-377
IDLER GEAR & BUSHING	650-378
IDLER GEAR BRONZE BUSHING ONLY	650-3781

# FLYWHEEL/FLEXPLATE SHIMS

- ★SPACES FLYWHEEL FROM CRANK FOR PROPER STARTER ALIGNMENT
- ★FORD OR CHEVY
- ★STACKABLE



DESCRIPTION	PART #
CHEVY FLYWHEEL SHIM, .030" THICK	650-177
CHEVY FLYWHEEL SHIM, .035" THICK	650-1771
CHEVY FLYWHEEL SHIM, .046" THICK	650-1772
CHEVY FLYWHEEL SHIM, .057" THICK	650-1773
CHEVY FLYWHEEL SHIM, .072" THICK	650-1774
86 & UP CHEVY FLY. SHIM, .030" THICK	650-1776
FORD FLYWHEEL SHIM, .030" THICK	650-176

Place your order at (479) 646-6988, Fax to (479) 646-5939, or visit [www.southwestspeed.com](http://www.southwestspeed.com)



# BERT ALUMINUM & MAGNESIUM BELLHOUSINGS

- ★BERT ALUMINUM & MAGNESIUM BELLHOUSINGS WILL WORK WITH BRINN & BERT TRANSMISSIONS
- ★BELLHOUSING ASSEMBLIES INCLUDE IDLER GEAR ASSEMBLY & FLYWHEEL (RING GEAR & REAR BELT DRIVE COUPLER IN EITHER 1, 2, OR 3 PIECE FORM)
- ★ALL ASSEMBLIES COME WITH A STEEL FLYWHEEL, BUT THERE IS AN ALUMINUM VERSION AVAILABLE
- ★BOTH GILMER & HTD REAR BELT DRIVE COUPLERS AVAILABLE
- ★USE W/ REVERSE MOUNT STARTERS, SUCH AS #499-811
- ★AVAILABLE FOR SBC, SBC 86 & UP, CHEVY CRATE (WHICH HAVE EXTERNALLY BALANCED FLYWHEELS), FORD, & MOPAR



DESCRIPTION	PART #
BELLHOUSING, CHEVY, ALUM., GILMER	650-340
BELLHOUSING, CHEVY, ALUM., HTD	650-341
BELLHOUSING, CHEVY, MAG., HTD	650-343
BELLHOUSING, CHEVY 86&UPALUM.,HTD	650-3439
BELLHOUSING, CHEVY CRATE,ALUM.,HTD	650-344
BELLHOUSING, FORD, ALUM., GILMER	650-345
BELLHOUSING, FORD, ALUM., HTD	650-346
BELLHOUSING, MOPAR, ALUM., HTD	650-348
SBC GILMER DRIVE COUPLER ONLY	650-303
SBC HTD DRIVE COUPLER ONLY	650-302
SBC FLYWHEEL RING GEAR ONLY	650-300
FORD FLYWHEEL RING GEAR ONLY	650-301
SBC 2 PIECE FLYWHEEL, GILMER, STEEL	650-310
SBC 2 PIECE FLYWHEEL, HTD, STEEL	650-311
SBC 2 PIECE FLYWHEEL, HTD, ALUM.	650-315
SBC 400 EXT. BAL., 1 PC FLY., HTD, STEEL	650-317
SBC 86 & UP 1 PIECE FLY., HTD, STEEL	650-322
SBC CRATE 1 PIECE FLY., HTD, STEEL	650-3192
SBC CRATE 1 PIECE FLY. WITH NO DRIVE	650-319
FORD 3 PIECE FLYWHEEL, GILMER,STEEL	650-312
FORD 3 PIECE FLYWHEEL, HTD, STEEL	650-313
MOPAR 1 PIECE FLYWHEEL, HTD, STEEL	650-318
IDLER GEAR & BUSHING ONLY	650-338
IDLER GEAR BUSHING ONLY	650-324
IDLER GEAR SHAFT ONLY	650-326
IDLER GEAR SHAFT BOLT ONLY	650-3261
IDLER GEAR SHAFT PLATE	650-327
IDLER GEAR SPRING	650-328
IDLER GEAR WASHER	650-329
IDLER GREASE FITTING ONLY	650-330

## PILOT BUSHING

- ★EXTRA LONG CHEVY BUSHING
- ★1/4" LONGER TO ALLOW FOR MOTOR PLATES



**PART #650-098**

# FALCON ALUMINUM & MAGNESIUM BELLHOUSINGS

- ★FALCON ALUMINUM & MAGNESIUM BELLHOUSINGS WILL WORK WITH FALCON TRANSMISSIONS
- ★BELLHOUSING ASSEMBLIES INCLUDE IDLER GEAR ASSEMBLY, FLYWHEEL (RING GEAR & HTD REAR BELT DRIVE COUPLER), PUMP ADAPTER MOUNTING BLOCK & BOLTS, AND SPACER SHIMS
- ★ALL ASSEMBLIES COME WITH A STEEL FLYWHEEL
- ★USE WITH REVERSE MOUNT STARTERS, SUCH AS #499-811
- ★AVAILABLE FOR SBC, SBC 86 & UP, CHEVY CRATE, & FORD



DESCRIPTION	PART #
BELLHOUSING, CHEVY, ALUMINUM	649-9820
BELLHOUSING, CHEVY, MAGNESIUM	649-9821
BELLHOUSING, CHEVY 86 & UP, MAG	649-9824
BELLHOUSING, CHEVY CRATE, MAG ***	649-9826
BELLHOUSING, FORD, MAGNESIUM	649-9830
BARE BELLHOUSING ONLY, CHEVY, ALUM	649-9854
RING GEAR ONLY, SBC, 63 TOOTH, 6 1/2"	649-9910
RING GEAR ONLY, SBC 86&UP, 63 T, 6 1/2"	649-9911
RING GEAR ONLY, FORD, 63 TOOTH, 6 1/2"	649-9914
CRANK COUPLER W/HTD DRIVE, SBC	649-9930
CRANK COUPLER W/HTD DR., SBC 86&UP	649-9931
CRANK COUPLER W/HTD DRIVE, FORD	649-9934
CRANK COUPLER, NO DRIVE, SBC	649-9920
CRANK COUPLER, NO DRIVE, SBC 86&UP	649-9921
CRANK COUPLER, NO DRIVE, FORD	649-9924
1 PC COUPLER & RING, NO DRIVE, CRATE	649-9926
IDLER GEAR	649-9862
IDLER GEAR BUSHING	649-9861
IDLER GEAR SHAFT	649-9858
IDLER GEAR RETURN SPRING	649-9859
IDLER GEAR THRUST WASHER	649-9860
IDLER SHAFT MOUNTING PLATE	649-9856
IDLER SHAFT MOUNT PLATE BOLT KIT, 2	649-9855
IDLER SHAFT ROLL PIN	649-9857
IDLER SHAFT GREASE FITTING	649-9863
PUMP ADAPTER MOUNTING BLOCK	649-9865
PUMP ADAPTER BLOCK BOLT KIT, 4 PCS.	649-9864
CRANK SHIM, .036", SBC	649-9900
CRANK SHIM, .036", SBC 86&UP & CRATE	649-9901
CRANK SHIM, .036", FORD	649-9904
***CHEVY CRATE BELLHOUSING HAS 1 PIECE CRANK COUPLER & RING GEAR WITH NO HTD DRIVE	

## DOWEL PINS

- ★1 1/2" EXTRA LONG DESIGN
- ★SIMPLIFIES INSTALLATION OF BELLHOUSING ON BLOCK
- ★SOLD IN PACKS OF 2



**PART #650-407**

Place your order at (479) 646-6988, Fax to (479) 646-5939, or visit [www.southwestspeed.com](http://www.southwestspeed.com)

# BRINN FLYWHEELS

- ★1 PIECE FLYWHEELS WITH RING GEAR & HTD REAR BELT DRIVE COUPLER TOGETHER
- ★AVAILABLE FOR CHEVY & FORD



#650-183

DESCRIPTION	PART #
SBC, 1 PC. FLYWHEEL, STEEL	650-183
SBC, 1 PC. FLYWHEEL, ALUMINUM	650-184
SBC 86 & UP, 1 PC. FLYWHEEL, STEEL	650-185
SBC CRATE, 1 PC. FLYWHEEL, STEEL	650-187
FORD, 1 PC. FLYWHEEL, STEEL	650-186
6 PC BOLT KIT, BRINN FLYWHEELS	650-001

# BERT FLYWHEELS

- ★BERT FLYWHEELS INCLUDE RING GEAR & REAR BELT DRIVE COUPLER IN 1, 2, OR 3 PIECE FORM
- ★BOTH HTD (ROUND TOOTH) & GILMER (SQUARE TOOTH) REAR BELT DRIVE COUPLERS AVAILABLE



#650-311  
2 PIECE  
SBC



#650-313  
3 PIECE  
FORD

DESCRIPTION	PART #
SBC GILMER DRIVE COUPLER ONLY	650-303
SBC HTD DRIVE COUPLER ONLY	650-302
SBC FLYWHEEL RING GEAR ONLY	650-300
SBC, 2 PC. FLYWHEEL, GILMER, STEEL	650-310
SBC, 2 PC. FLYWHEEL, HTD, STEEL	650-311
SBC, 2 PC. FLYWHEEL, HTD, ALUMINUM	650-315
SBC 400 EXT. BAL., 1 PC FLY, HTD, STEEL	650-317
SBC 86 & UP, 1 PC. FLY., HTD, STEEL	650-322
SBC CRATE, 1 PC. FLY., HTD, STEEL	650-3192
SBC CRATE, 1 PC. FLY., WITH NO DRIVE	650-319
FORD FLYWHEEL RING GEAR ONLY	650-301
FORD, 3 PC. FLYWHEEL, GILMER, STEEL	650-312
FORD, 3 PC. FLYWHEEL, HTD, STEEL	650-313
MOPAR, 1 PC. FLYWHEEL, HTD, STEEL	650-318
6 PC BOLT KIT, BERT FLYWHEELS	650-048

# FALCON FLYWHEELS

- ★2 PIECE FLYWHEELS WITH RING GEAR & HTD REAR BELT DRIVE COUPLER SOLD SEPARATELY, EXCEPT FOR THE CRATE, WHICH IS A 1 PIECE RING GEAR & COUPLER WITH NO DRIVE



#649-9910

#649-9930

DESCRIPTION	PART #
SBC FLYWHEEL RING GEAR ONLY	649-9910
SBC HTD DRIVE COUPLER ONLY	649-9930
SBC 86&UP FLYWHEEL RING GEAR ONLY	649-9911
SBC 86&UP HTD DRIVE COUPLER ONLY	649-9931
FORD FLYWHEEL RING GEAR ONLY	649-9914
FORD HTD DRIVE COUPLER ONLY	649-9934
SBC CRATE, 1 PC. FLYWHEEL, NO DRIVE	649-9926
6 PC BOLT KIT, FALCON FLYWHEELS	650-0017

# DIRECT DRIVE COUPLERS

- ★COUPLES BERT, BRINN, FALCON, OR CHEVY TRANSMISSION TO CHEVY & FORD MOTORS

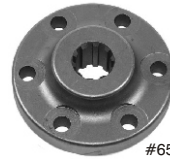

#650-050



#650-069



#650-070

DESCRIPTION	PART #
1 1/8"-10 SPLINE CHEVY, STEEL	650-050
1 3/8"-10 BERT, STEEL, CHEVY	650-069
1 3/8"-10 BERT, ALUM., CHEVY	650-071
1 3/8"-10 BRINN, STEEL, CHEVY	650-070
1 3/8"-10 BRINN, ALUM., CHEVY	650-072
1 3/8"-10 BERT/BRINN, STEEL, SBC 86&UP	650-092
1 3/8"-10 BERT/BRINN, STEEL, SBC CRATE	650-088
1 3/8"-10 BERT/BRINN, STEEL, SBC LS-1	650-089
1 3/8"-10 BERT/BRINN, STEEL, FORD	650-078
1 3/8"-10 BERT/BRINN, ALUM., FORD	650-080
1 3/8"-10 BERT/BRINN, STEEL, PINTO 2300	650-082
1 9/16"-18 FALCON, STEEL, CHEVY	649-9920
1 9/16"-18 FALCON, STEEL, SBC 86&UP	649-9921
1 9/16"-18 FALCON, STEEL, FORD	649-9924
6 PIECE BOLT KIT, BERT COUPLER	650-001
6 PIECE BOLT KIT, BRINN COUPLER	650-048
6 PIECE BOLT KIT, FALCON COUPLER	650-0017
ADAPTER, FORD CRANK TO CHEVY HUB	650-095

# DIRECT DRIVE COUPLERS & HTD DRIVES - 1 PIECE

- ★USE WITH BERT OR BRINN TRANSMISSIONS TO RUN A PUMP OFF THE BACK OF THE MOTOR
- ★WITH THESE COUPLERS, IT ISN'T NECESSARY TO HAVE A BERT OR BRINN BELLHOUSING
- ★MUST USE FLYWHEEL OR FLEXPLATE W/ A STARTER RING
- ★22 TEETH HTD PUMP DRIVES
- ★1 3/8"-10 SPLINES



DESCRIPTION	PART #
CRANK HUB, ALUM., 1 3/8"-10, CHEVY	650-093
CRANK HUB, STEEL, 1 3/8"-10, CHEVY	QMI 180-131
CRANK HUB, ST., 1 3/8", CHEVY 86&UP	QMI 180-134

\*ALUMINUM BELT GUIDE FOR #650-093 IS #650-164 & FOR #QMI 180-131 IS #QMI 180-1312

# POWERGLIDE COUPLERS - DIRECT DRIVE

- ★SMALL BLOCK CHEVY
- ★ALUMINUM OR STEEL HUB
- ★STEEL SHAFTS
- ★FITS POWERGLIDE ONLY
- ★REPLACES TORQUE CONVERTER



DESCRIPTION	PART #
DIRECT DRIVE POWERGLIDE KIT, STEEL	650-029
DIRECT DRIVE POWERGLIDE KIT, ALUM.	650-030
DIR. DR. POWERGLIDE KIT, STEEL, 86&UP	650-031
REPLACEMENT SPIRAL LOCK RING	650-033

Place your order at (479) 646-6988, Fax to (479) 646-5939, or visit [www.southwestspeed.com](http://www.southwestspeed.com)

# BRINN TRANSMISSIONS & PARTS

- ★LIGHTWEIGHT: 42 TO 49 LBS., DEPENDING ON MODEL
- ★INTERNAL CLUTCH ELIMINATES NEED FOR EXTERNAL CLUTCH ASSEMBLY & THROWOUT BEARING ASSEMBLY
- ★REVERSE IDLER & LOW SPEED GEAR ARE NOT ENGAGED IN DIRECT DRIVE
- ★GUN-DRILLED INPUT & OUTPUT SHAFTS
- ★SAME LENGTH & OUTPUT SPLINE AS A MUNCIE & A BORG-WARNER
- ★DOG-CLUTCH & DETENT DESIGN ELIMINATE THE NEED FOR SPECIAL SHIFTERS
- ★SEPARATE LOW & REVERSE GEARS MAKE SHIFTING PRECISE
- ★DESIGNED FOR EASY ASSEMBLY, DISASSEMBLY, & SERVICE
- ★THE BRINN PRO SERIES TRANSMISSION HAS NO GEARS ENGAGED IN DIRECT DRIVE, HAS THE LOWEST ROTATING WEIGHT OF JUST 11 LBS., & HAS THE MOST GROUND CLEARANCE OF ANY TRANSMISSION

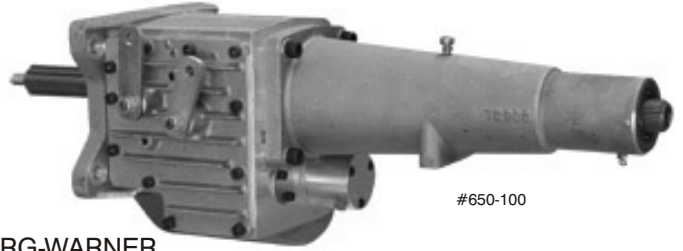

#650-100

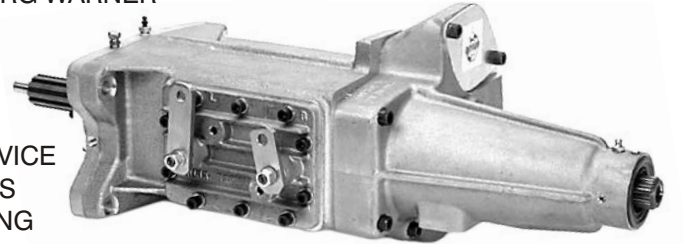

#650-106

SEE PAGES 142 & 143 FOR DIAGRAMS OF THE BRINN TRANSMISSION

DESCRIPTION	PART #
BRINN TRANSMISSION, ALUMINUM	650-100
BRINN TRANSMISSION, MAGNESIUM	650-102
BRINN TRANSMISSION, PRO SERIES, MAG.	650-106
BRINN TRANSMISSION, PRO SERIES 2.0, MAG.	650-104
SMALL PARTS REBUILD KIT**	650-141
MAIN CASE	650-107
SIDE COVER / SHIFT PLATE, BARE	650-1071
SIDE COVER BOLT KIT, 11 PIECES	650-1070
SIDE COVER SET SCREW, NYLOCK	650-1250
FRONT SEAL PLATE	650-1072
FRONT SEAL PLATE BOLT KIT, 6 PIECES	650-1074
FRONT SEAL PLATE WITH CLUTCH ASSEMBLY FOR BRINN PRO SERIES ONLY	650-145
FILL PLUG	650-1078
MAGNETIC DRAIN PLUG	650-1079
TAILHOUSING ASSEMBLY	650-113
TAILHOUSING BOLT KIT, 4 PIECES	650-1128
TAILHOUSING BRASS TIP SET SCREW	650-1132
TAILHOUSING GREASE FITTING	650-1133
TAILHOUSING VENT	650-1139
OUTPUT SHAFT	650-110
FIRST DRIVEN GEAR SPACER	650-1083
FIRST DRIVEN GEAR BEARING	650-1084
FIRST DRIVEN GEAR	650-1085
OUTPUT SHAFT SPACER, FIRST>REVERSE	650-1086
REVERSE DRIVEN GEAR	650-1087
OUTPUT SHAFT SPACER, REVERSE>BEARING	650-1088
OUTPUT SHAFT SNAP RING	650-1089
FRONT TAILHOUSING BEARING	650-123
TAILHOUSING BEARING SNAP RING	650-122
TAILHOUSING REAL SEAL & BUSHING SET	650-140
REAR SEAL SET SCREW KIT, 2 PIECES	650-1402
FORWARD CLUTCH RING, ALUMINUM	650-1148
O-RING, CLUTCH PACK SHAFT > FRONT CASE	650-1149
FRONT THRUST RACE, CLUTCH PACK	650-1150
COUNTER SHAFT, CLUTCH PACK	650-1152
THRUST WASHER, FRONT, COUNTER SHAFT	650-1153
THRUST BEARING, COUNTER SHAFT	650-1154
O-RING, CLUTCH RING>CL INPUT DRIVE GEAR	650-1155
THRUST WASHER, REAR, COUNTER SHAFT	650-1156
ROLL PIN, REAR, COUNTER SHAFT	650-1157
CAGED BEARING, FRONT&REAR, CNTR SHAFT	650-1158
THRUST WASHER, REAR, CLUTCH PACK	650-1159
CLUTCH RELEASE SPRING	650-116
NEEDLE THRUST BEARING,REAR,CLUTCH PAC	650-1160
FRONT BEARING, COUNTER SHAFT GEAR	650-1161

DESCRIPTION	PART #
CLUTCH ACTUATOR PIN	650-1162
CLUTCH ACTUATOR PISTON	650-1163
CLUTCH PISTON O-RING	650-1164
CLUTCH PISTON HOUSING	650-1165
CLUTCH PISTON CAP BOLT KIT, 3 PIECES	650-1166
CLUTCH BLEEDER VALVE ASSEMBLY	650-1167
CLUTCH DRUM	650-126
CLUTCH INPUT DRIVE GEAR	650-127
CLUTCH OUTPUT DRIVEN GEAR	650-1916
COUNTER SHAFT RETAINER	650-1918
INTERMEDIATE SHAFT WITH REV. INPUT GEAR	650-192
CLUTCH DISC PACK, HEAVY-DUTY, 6 PIECES	650-131
CLUTCH DRIVE PLATE KIT, STEEL, 5 PIECES	650-117
REAR CLUTCH DISC PLATE, STEEL	650-121
INPUT SHAFT	650-120
INPUT SHAFT SEAL	650-1201
INPUT BEARING RETAINING RING	650-1202
INPUT SHAFT BEARING	650-1203
INPUT SHAFT REAR BRASS BUSHING	650-112
REVERSE IDLER SHAFT	650-1331
REVERSE IDLER GEAR WITH BUSHING	650-133
REVERSE IDLER GEAR FRONT BUSHING	650-1332
REVERSE IDLER SHAFT COVER	650-1333
REVERSE IDLER SHAFT COVER BOLT KIT, 2 PC.	650-1334
REVERSE IDLER SHAFT ROLL PIN	650-1917
SHIFTER SLEEVE	650-124
REVERSE SHIFT FORK	650-1241
HIGH/LOW SHIFT FORK	650-1242
SHIFT LEVER	650-1243
REVERSE SHIFT ROD, INTERNAL	650-1244
HIGH/LOW SHIFT ROD, INTERNAL	650-1245
SHIFT ROD DETENT SPRING	650-1246
SHIFT LEVER O-RING	650-1708
EXTERNAL SHIFT LEVER, REVERSE	650-171
EXTERNAL SHIFT LEVER, HIGH	650-172
LOCKOUT SPRING, INTERLOCK	650-1247
DETENT BALL LOCKOUT KIT, 4 PIECES	650-1248
DETENT PIN, SHIFT RAIL LOCKOUT	650-1249
SHIFT FORK ROLL PIN	650-1251

\*\*650-141 SMALL PARTS REBUILD KIT INCLUDES:  
 6 PIECE HEAVY-DUTY CLUTCH DISC PACK, 5 PIECE STEEL CLUTCH DRIVE PLATE KIT, 1 CLUTCH RELEASE SPRING, 1 TAILHOUSING REAR BUSHING & SEAL, 1 INPUT SHAFT SEAL, 1 BRASS INPUT SHAFT REAR BUSHING, 1 CLUTCH ASSEMBLY FRONT THRUST RACE, 2 CLUTCH PACK THRUST TORRINGTON BEARINGS (1 FRONT & 1 REAR), 1 CLUTCH SHAFT TO MAIN CASE O-RING, 1 CLUTCH PISTON O-RING, 1 EXTERNAL SNAP RING, AND 4 SHIFTER LEVER O-RINGS

Place your order at (479) 646-6988, Fax to (479) 646-5939, or visit [www.southwestspeed.com](http://www.southwestspeed.com)



# BRINN TRANSMISSION DIAGRAM - SIDE VIEW 1

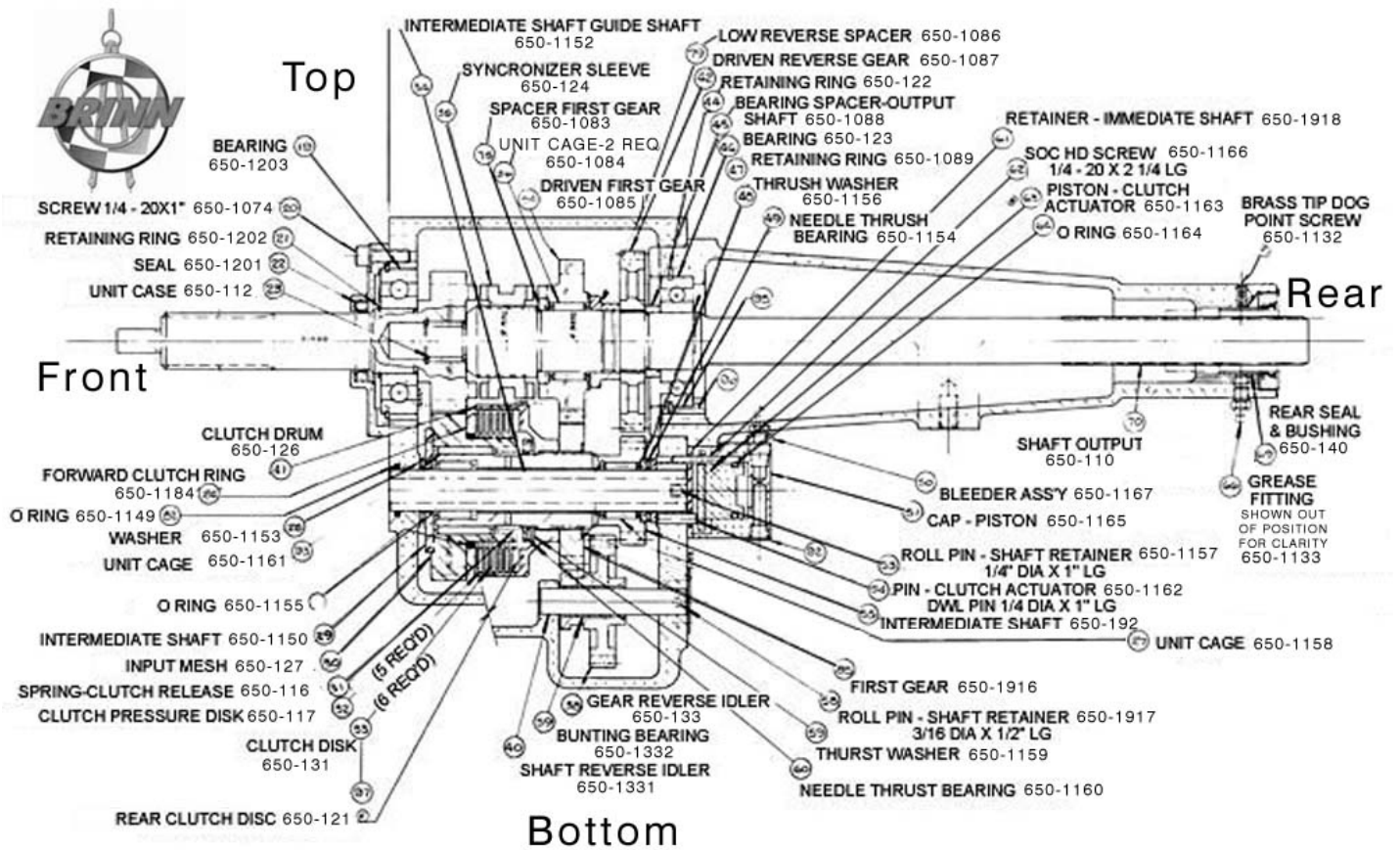

# BRINN TRANSMISSION DIAGRAM - SIDE VIEW 2

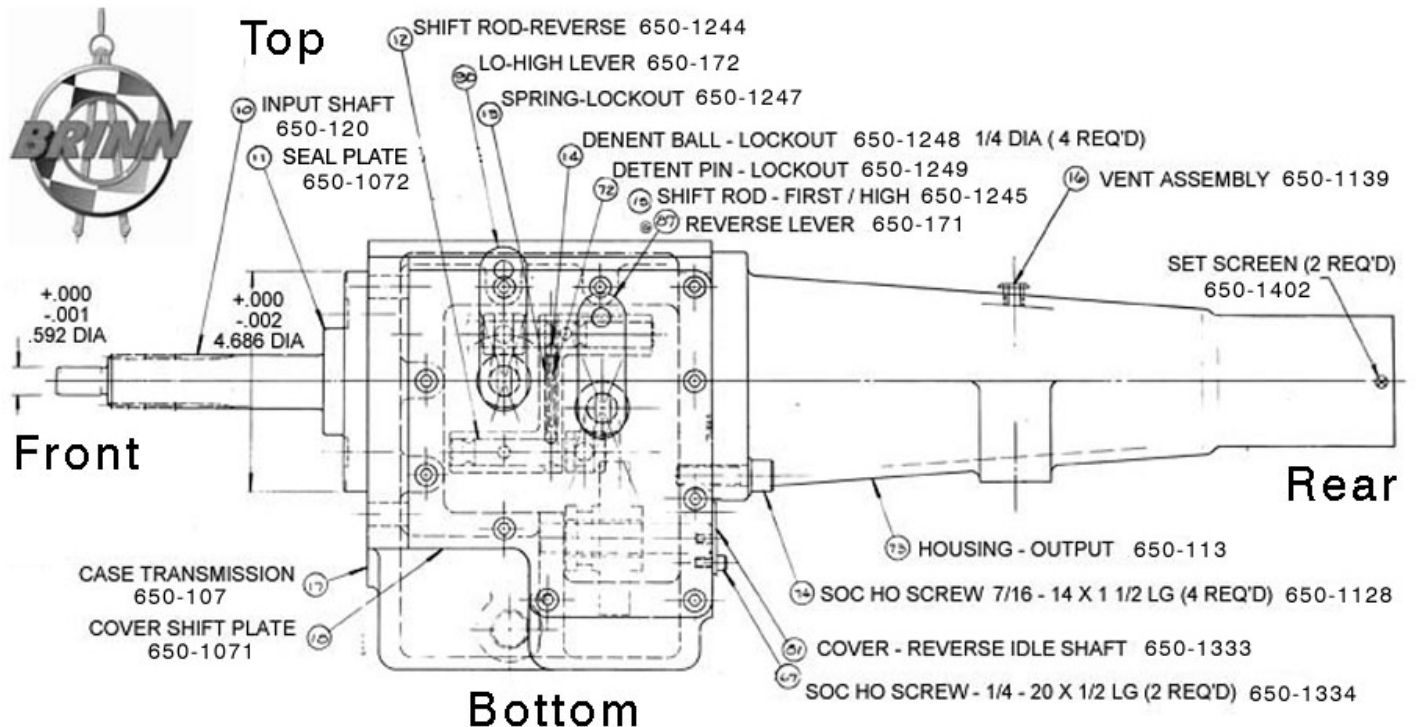

Place your order at (479) 646-6988, Fax to (479) 646-5939, or visit [www.southwestspeed.com](http://www.southwestspeed.com)

# BRINN INTERNAL CLUTCH DIAGRAM - SIDE VIEW

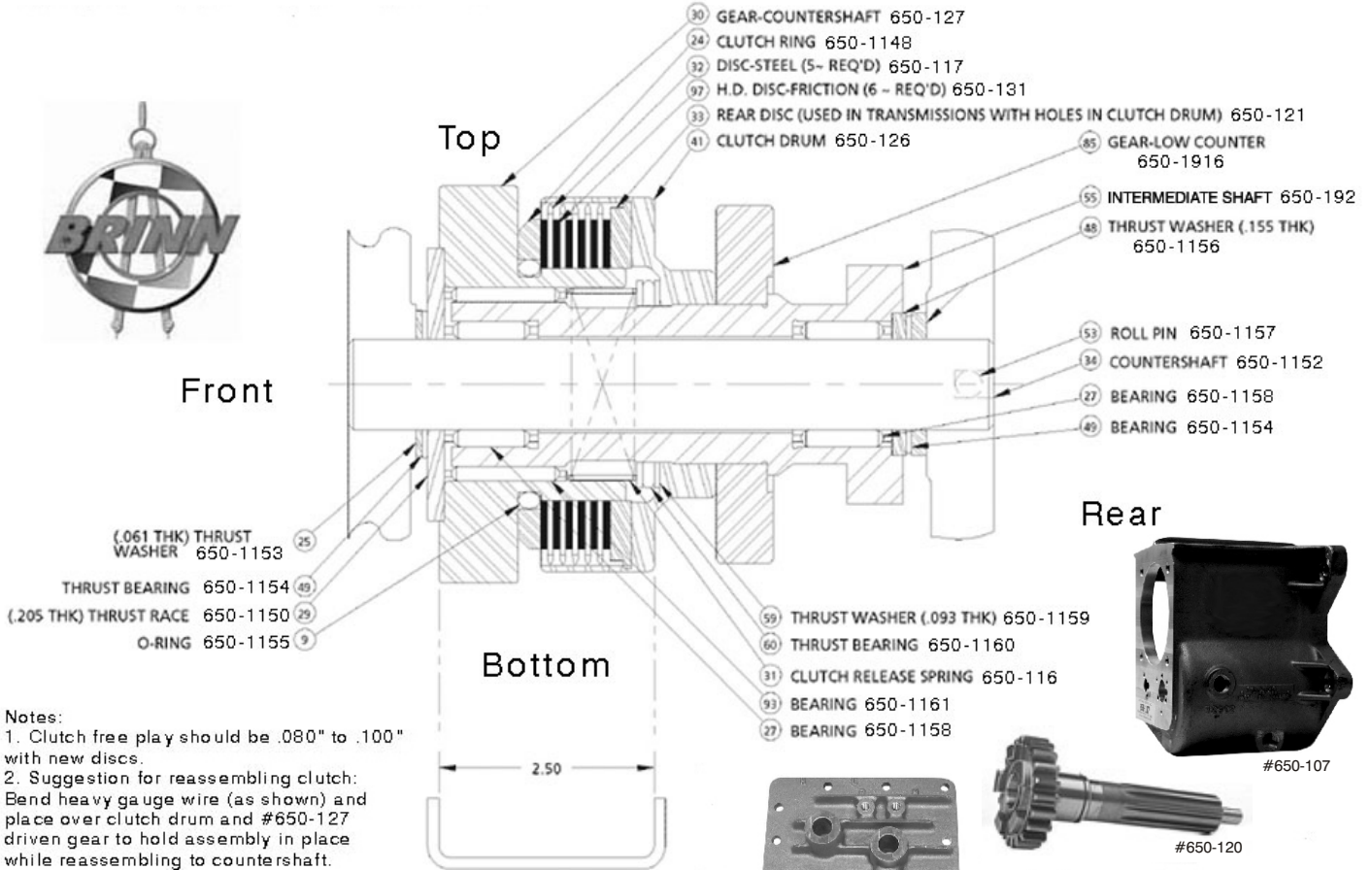

# BRINN TRANS. DIAGRAM - FRONT VIEW FROM BEHIND FRONT MOUNTING FLANGE

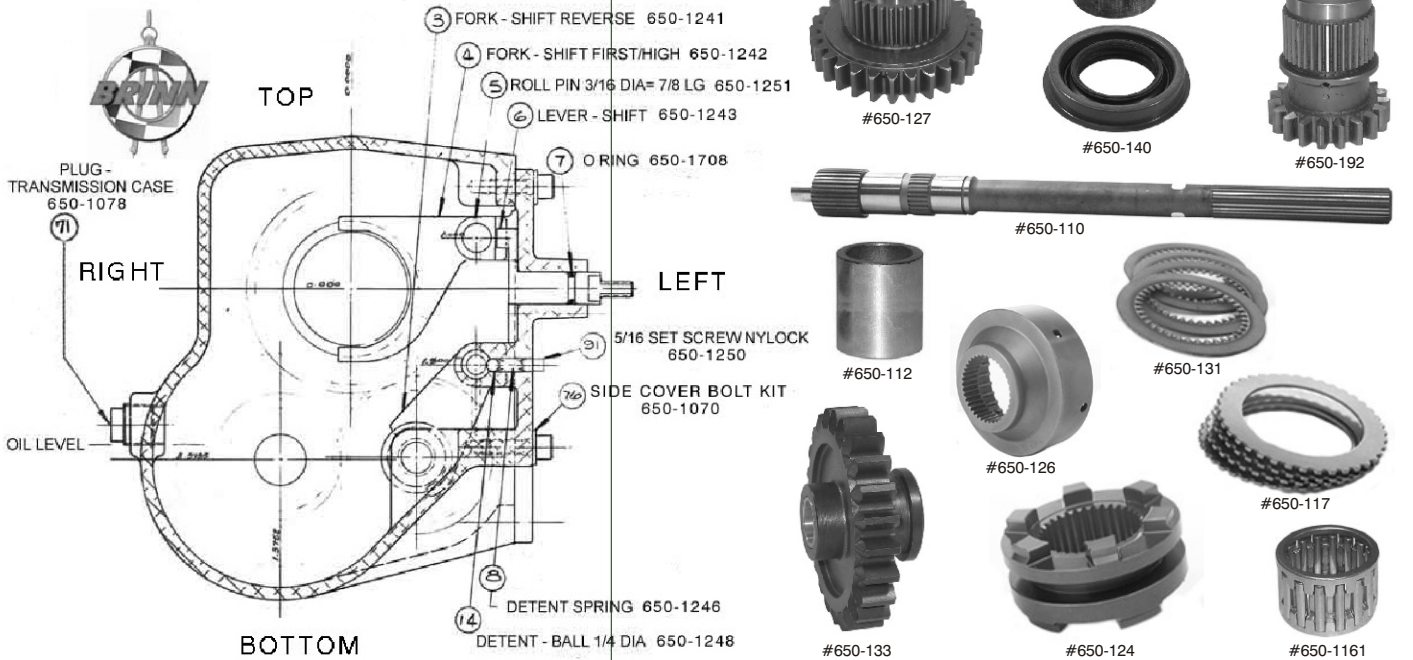

Place your order at (479) 646-6988, Fax to (479) 646-5939, or visit [www.southwestspeed.com](http://www.southwestspeed.com)



# BERT TRANSMISSIONS & PARTS

- ★LIGHTWEIGHT ALUMINUM OR MAGNESIUM CASE & TAILHOUSING
- ★INTERNAL CLUTCH ELIMINATES NEED FOR EXTERNAL CLUTCH ASSEMBLY & THROWOUT BEARING ASSEMBLY
- ★DIRECT DRIVE IN HIGH GEAR
- ★GUN-DRILLED INPUT & OUTPUT SHAFTS
- ★ALSO AVAILABLE ARE BERT BALLSPLINE TRANSMISSIONS, WHICH CONTAIN THE DRIVESHAFT SLIP YOKE IN THE TAILHOUSING, MAKING IT UNABLE TO PULL OUT

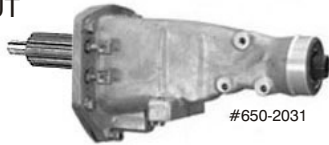

SEE PAGE 145 FOR A DIAGRAM OF THE BERT TRANSMISSION

DESCRIPTION	PART #
BERT TRANSMISSION, ALUMINUM	650-200
BERT TRANSMISSION, MAGNESIUM	650-201
BERT BALLSPLINE TRANSMISSION, ALUMINUM	650-2059
BERT BALLSPLINE TRANSMISSION, MAGNES.	650-206
OVERHAUL KIT**	650-210
MASTER OVERHAUL KIT***	650-211
TAILHOUSING ASSEMBLY	650-2031
BARE TAILHOUSING	650-203
SIDE COVER	650-204
FRONT SEAL COVER	650-205
FRONT SEAL PLATE BOLT KIT	650-2052
MAIN CASE	650-207
AIR VENT	650-2071
MAGNETIC FILL PLUG	650-2072
MAIN CASE DRAIN PLUG	650-2073
INPUT SHAFT	650-209
INPUT SHAFT SNAP RING	650-2092
INPUT SHAFT OIL SEAL	650-229
INPUT SHAFT BEARING	650-232
CAGED NEEDLE BEARING, INPUT & REV. IDLER	650-2096
DOG TOOTH SLIDER	650-212
OUTPUT SHAFT	650-213
SNAP RING FOR OUTPUT SHAFT	650-2561
OUTPUT SHAFT BEARING	650-256
SNAP RING FOR OUTPUT SHAFT BEARING	650-2559
COUNTER SHAFT LOCKING WASHER	650-2140
COUNTER SHAFT LOCKING WASHER BOLT	650-2141
FRONT COUNTER SHAFT	650-216
FRONT COUNTER SHAFT O-RING	650-2168
FRONT COUNTER GEAR	650-221
CAGED NEEDLE BEARING, FRONT CNTR GEAR	650-2213
COUNTER THRUST NEEDLE BEARING	650-2214
COUNTER THRUST WASHER, .030"	650-2215
COUNTER THRUST WASHER, .060"	650-2216
COUNTER THRUST WASHER, .090"	650-2217
COUNTER GEAR SPRING	650-222
REAR COUNTER GEAR, LIGHTWEIGHT	650-223
CAGED NEEDLE BEARING, REAR CNTR GEAR	650-2233
CLUTCH PUSH SLEEVE	650-2240
CLUTCH PUSH SLEEVE KEY	650-2241
FLOATER PLATE KIT, STEEL, 5 PCS.	650-228
CLUTCH PACK, HEAVY-DUTY, 6 PCS.	650-230
HIGH GEAR SHIFTING FORK	650-241
SHIFTING ROD SEAL	650-2412
SHIFT ROD DETENT BALL, 5/16"	650-2413
DETENT SPRING, LOW	650-2414
DETENT SPRING, HIGH-GEAR	650-2415

DESCRIPTION	PART #
SHIFTING ROD FRONT PLUG, 3/4"	650-2419
HIGH/LOW SHIFTING ROD	650-2420
REVERSE SHIFTING ROD	650-2421
REVERSE IDLER GEAR	650-244
REVERSE IDLER GEAR SNAP RING	650-2443
REVERSE IDLER SHAFT	650-247
REVERSE IDLER SHAFT WOODRUFF KEY	650-2472
CLUTCH PISTON	650-2567
CLUTCH PRESSURE CUP, 1 3/8"	650-2568
CLUTCH PISTON CUP EXTENDER	650-2569
CLUTCH PISTON SPRING	650-2570
TAILHOUSING BOLT & WASHER KIT	650-2590
TAILHOUSING BUSHING	650-260
TAILHOUSING REAR SEAL	650-265
SHIFTING ROD INTERLOCK PIN	650-267
DETENT SPRING RETAINING PLUG	650-2672
REAR YOKE SPACER, CLOSED DRIVE	650-269
FRONT CLUTCH SPACER	650-270
SHIFTING FORK RETAINING PIN	650-271
REVERSE GEAR SHIFTING FORK	650-275
SHIFTER ASSEMBLY WITH HIGH GEAR LOCK	650-280
SHIFTER SOLID ROD END, 3/8" MALE	650-2802
1/8" NPT, 90 DEGREE, INLET FITTING	650-282
1/8" NPT MALE, BLEEDER ADAPTER	650-283
BERT BALLSPLINE PARTS	PART #
TAILHOUSING ASSEMBLY, BALLSPLINE	650-2035
BARE TAILHOUSING, BALLSPLINE	650-2033
OUTPUT SHAFT, BALLSPLINE	650-2135
TAILHOUSING OVERHAUL KIT, BALLSPLINE	650-2098
TAILHOUSING SEAL, BALLSPLINE	650-2034
BALL RETAINING HOUSING, BALLSPLINE	650-2136
STEEL BALL KIT, 12 PCS, BALLSPLINE	650-2137
OUTPUT SHAFT ASSY. & YOKE, BALLSPLINE	650-2138
BALL WASHER SEAL, BALLSPLINE	650-2139
OUTPUT YOKE, ALUMINUM, BALLSPLINE	650-2145
**650-210 OVERHAUL KIT INCLUDES 6 PC HEAVY-DUTY CLUTCH PACK, 1 TAILHOUSING BUSHING, 1 TAILHOUSING REAR SEAL, 1 INPUT SHAFT OIL SEAL, 2 SHIFTING FORK RETAINING PINS, 2 SHIFTING ARM SEALS, 2 MAIN CASE SHIFTING ROD PLUGS, 1 HYDRAULIC CLUTCH CUP - 1 3/8", AND 1 FRONT COUNTER SHAFT O-RING	
***#650-211 MASTER OVERHAUL KIT INCLUDES EVERYTHING IN THE #650-210 KIT, PLUS 1 INPUT SHAFT BEARING, 1 OUTPUT SHAFT BEARING, 2 CAGED NEEDLE BEARINGS FOR INPUT SHAFT & REVERSE IDLER GEAR, 2 CAGED NEEDLE BEARINGS FOR FRONT COUNTER GEAR, 2 CAGED NEEDLE BEARINGS FOR REAR COUNTER GEAR, 3 COUNTER THRUST FLAT ROLLER BEARINGS, AND 7 COUNTER THRUST WASHERS (1 - .030" THICK, 4 - .060" THICK, & 2 - .090" THICK)	

Place your order at (479) 646-6988, Fax to (479) 646-5939, or visit [www.southwestspeed.com](http://www.southwestspeed.com)



# BERT TRANSMISSION DIAGRAM - LEFT SIDE VIEW

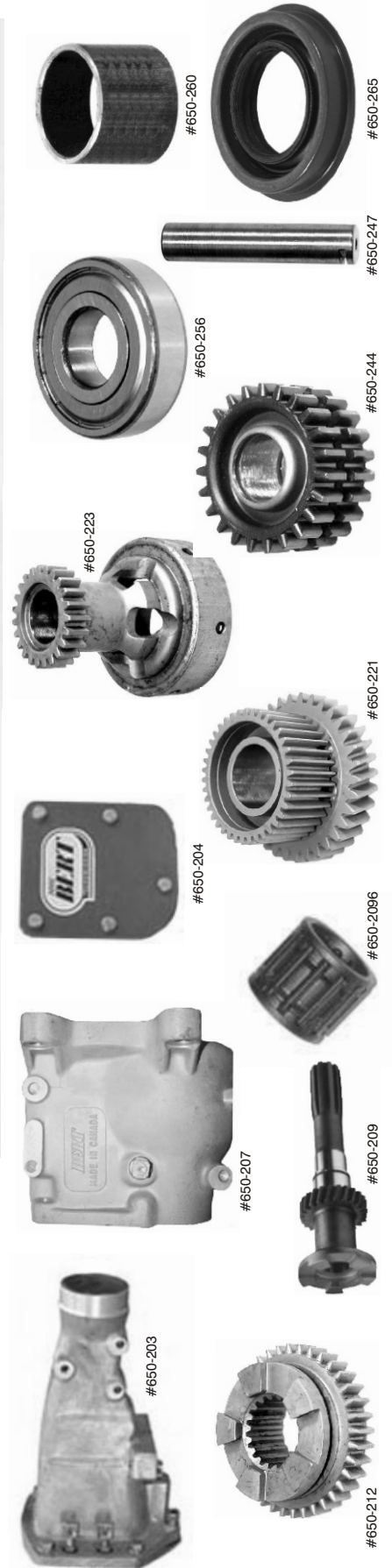
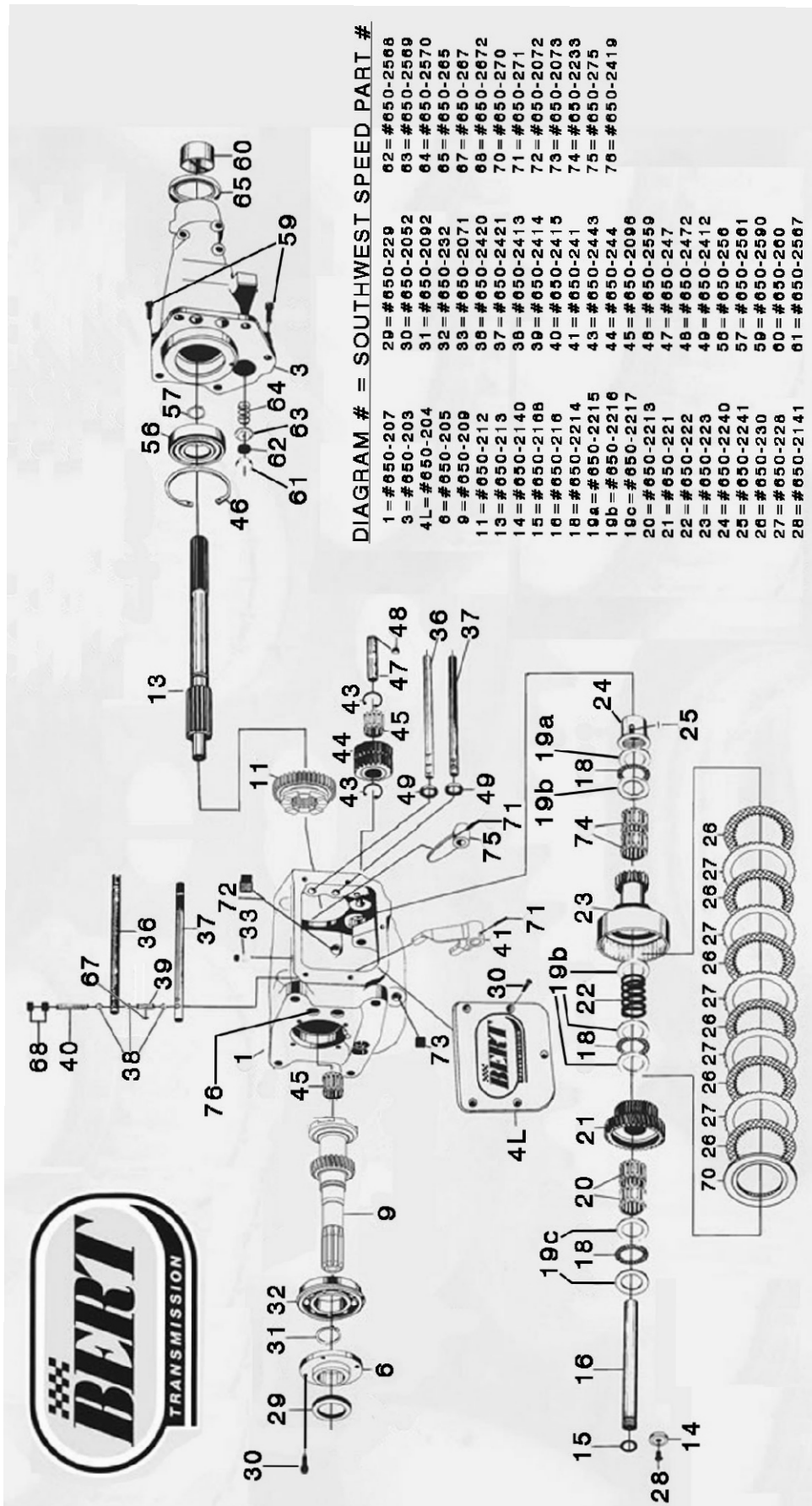

Place your order at (479) 646-6988, Fax to (479) 646-5939, or visit [www.southwestspeed.com](http://www.southwestspeed.com)

# FALCON TRANSMISSIONS & PARTS

- ★LIGHTWEIGHT ALUMINUM CASE & TAILHOUSING
- ★WEIGHS ONLY 43 LBS.
- ★INTERNAL CLUTCH ELIMINATES NEED FOR EXTERNAL CLUTCH ASSEMBLY & THROWOUT BEARING ASSEMBLY
- ★INTEGRAL HYDRAULIC APPLIED CLUTCH OPERATES BOTH LOW & REVERSE GEARS
- ★HIGH GEAR IS A DIRECT DRIVE 1 TO 1 RATIO
- ★FLOATING INPUT SHAFT CONTRIBUTES TO THE MOST POSITIVE HIGH GEAR RETENTION IN THE INDUSTRY
- ★FRICTIONLESS BEARINGS SUPPORT ALL ROTATING COMPONENTS
- ★FALCON TRANSMISSIONS COME WITH THE DIRECT DRIVE COUPLER, COUPLER SHAFT, COLLAR, & SNAP RING; NO ADDITIONAL ITEMS ARE NEEDED FOR THE FRONT OF A FALCON

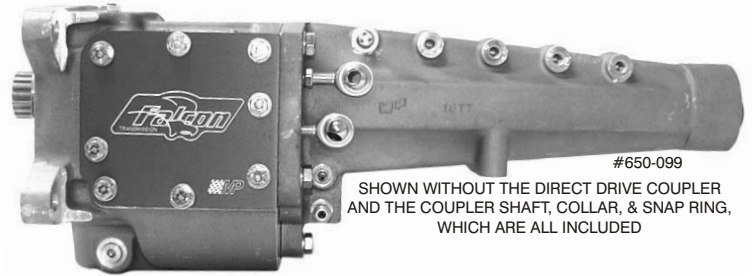

SEE PAGE 147 FOR A DIAGRAM OF THE FALCON TRANSMISSION



DESCRIPTION	PART #
FALCON TRANSMISSION, ALUMINUM	650-099
SMALL PARTS REBUILD KIT**	649-9741
MASTER OVERHAUL KIT***	649-9743
MAIN CASE	649-9700
MAIN CASE REAR GASKET	649-9701
FRONT SEAL PLATE	649-9702
FRONT SEAL PLATE O-RING	649-9703
FRONT SEAL PLATE BOLT KIT, 4 PIECES	649-9760
INPUT SHAFT, 18 SPLINE, 24 TOOTH	649-9707
INPUT SHAFT SEAL	649-9704
INPUT SHAFT BEARING	649-9706
INPUT SHAFT BEARING SNAP RING	649-9705
INPUT SHAFT CENTER PLUG	649-9708
INPUT SHAFT PLUG RETAINING RING	649-9709
CLUTCH PUSH ROD	649-9710
CLUTCH PISTON	649-9712
CLUTCH PISTON THRUST WASHER	649-9711
CLUTCH PISTON O-RING	649-9713
SHIFT RAIL DETENT PIN	649-9720
SHIFT RAIL DETENT BALL SET, 3 PIECES	649-9721
SHIFT RAIL TOP DETENT SPRING	649-9722
SHIFT RAIL DETENT SCREW JAM NUT	649-9723
SHIFT RAIL DETENT SCREW	649-9724
SHIFT RAIL SIDE DETENT SPRING SET, 2 PCS.	649-9725
SIDE COVER	649-9727
SIDE COVER GASKET	649-9726
SIDE COVER WASHER SET, 8 PIECES	649-9728
SIDE COVER BOLT SET, 8 PIECES	649-9729
MAIN SHIFT YOKE, LOW/NEUTRAL/HIGH	649-9730
MAIN SHIFT YOKE SET SCREW	649-9731
REVERSE SHIFT YOKE	649-9732
REVERSE SHIFT YOKE SET SCREW	649-9733
REVERSE SHIFT RAIL	649-9734
MAIN SHIFT RAIL, LOW/NEUTRAL/HIGH	649-9735
SHIFT RAIL SEAL SET, 2 PIECES	649-9736
SHIFT RAIL PLUG	649-9744
COUNTER SHAFT	649-9740
COUNTER SHAFT O-RING	649-9737
COUNTER SHAFT ROLL PIN	649-9738
COUNTER SHAFT END PLUG	649-9739
COUNTER SHAFT THRUST WASHER SET, 6 PC.	649-9745
COUNTER SHAFT THRUST BEARING SET, 3 PC.	649-9746
CLUTCH PACK HUB, 38 TOOTH	649-9747
CLUTCH PACK SPACER, ALUMINUM, 38 TOOTH	649-9748
STEEL CASED NEEDLE BEARING, CLUTCH HUB	649-9749
CLUTCH SPRING	649-9750
CLUTCH SPRING SPACER	649-9751
COUNTER SHAFT RETAINING RING	649-9752
CLUTCH DISC PACK, FRICTION, 6 PIECE	649-9753
CLUTCH DRIVE PLATE KIT, STEEL, 5 PIECE	649-9754
CLUTCH PACK ASSEMBLY SHAFT	649-9799

DESCRIPTION	PART #
CLUTCH GEAR	649-9755
CLUTCH GEAR NEEDLE BEARING SET, 2 PCS.	649-9756
CLUTCH GEAR NEEDLE BEARING SPACER	649-9757
CLUTCH GEAR REAR THRUST WASHER	649-9758
REVERSE COUNTER SHAFT	649-9767
REVERSE SHAFT O-RING	649-9765
REVERSE SHAFT ROLL PIN	649-9766
REVERSE IDLER GEAR	649-9770
REVERSE IDLER GEAR SNAP RING	649-9768
REVERSE IDLER GEAR NEEDLE BEARING	649-9769
SLIDING GEAR	649-9771
REAR SHAFT SNAP RING	649-9772
REAR SHAFT BEARING	649-9773
REAR SHAFT BEARING SNAP RING, LARGE	649-9774
REAR SHAFT NEEDLE BEARING SET, 2 PCS.	649-9776
REAR SHAFT NEEDLE BEAR. SNAP RING SET, 2	649-9775
REAR SHAFT NEEDLE BEARING SPACER	649-9777
OUTPUT SHAFT BOLT	649-9778
OUTPUT SHAFT WASHER	649-9779
REAR INTERMEDIATE SHAFT	649-9780
OUTPUT SHAFT	649-9781
OUTPUT SHAFT RETAINING RING	649-9782
TAILHOUSING	649-9783
TAILHOUSING BEARING	649-9788
YOKE BEARING SNAP RING	649-9789
YOKE SEAL	649-9790
YOKE SEAL SNAP RING	649-9791
TAILHOUSING BOLT SET, 5 PIECES	649-9718
TAILHOUSING WASHER SET, 5 PIECES	649-9719
VENT BREATHER	649-9714
BLEEDER SCREW	649-9715
BLEEDER SCREW ADAPTER	649-9716
INLET LINE COMPRESSION FITTING	649-9717
FILL PLUG	649-9793
DRAIN PLUG	649-9794
CRANK COUPLER SHAFT, 18/18 SPLINE	649-9950
CRANK COUPLER COLLAR, 18/18 SPLINE	649-9952
CRANK COUPLER COLLAR SNAP RING	649-9954
**649-9741 SMALL PARTS REBUILD KIT INCLUDES 6 PIECE CLUTCH DISC PACK, 5 PIECE CLUTCH PLATE SET, 1 TAILHOUSING GASKET, 1 SIDE COVER GASKET, 2 SHIFT RAIL PLUGS, 1 YOKE SEAL, 1 INPUT SHAFT SEAL, 2 SHIFT RAIL SEALS, 1 FRONT SEAL PLATE O-RING, 1 CLUTCH PISTON O-RING, 1 COUNTER SHAFT O-RING, AND 1 REVERSE SHAFT O-RING	
***#649-9743 MASTER OVERHAUL KIT INCLUDES EVERYTHING IN THE #649-9741 KIT, PLUS 3 THRUST BEARINGS, 1 CLUTCH HUB BEARING, 1 YOKE NEEDLE BEARING, 2 REAR SHAFT NEEDLE BEARINGS, 2 CLUTCH GEAR NEEDLE BEARINGS, 1 REVERSE IDLER NEEDLE BEARING, 1 REAR SHAFT BALL BEARING, AND 1 INPUT SHAFT BALL BEARING	

NOTE: FOR A CONSTANT STREAM OF NEW PRODUCTS & UP-TO-THE-SECOND PRICING, VISIT [WWW.SOUTHWESTSPEED.COM](http://WWW.SOUTHWESTSPEED.COM)

Place your order at (479) 646-6988, Fax to (479) 646-5939, or visit [www.southwestspeed.com](http://www.southwestspeed.com)



# FALCON TRANSMISSION DIAGRAM - LEFT SIDE VIEW

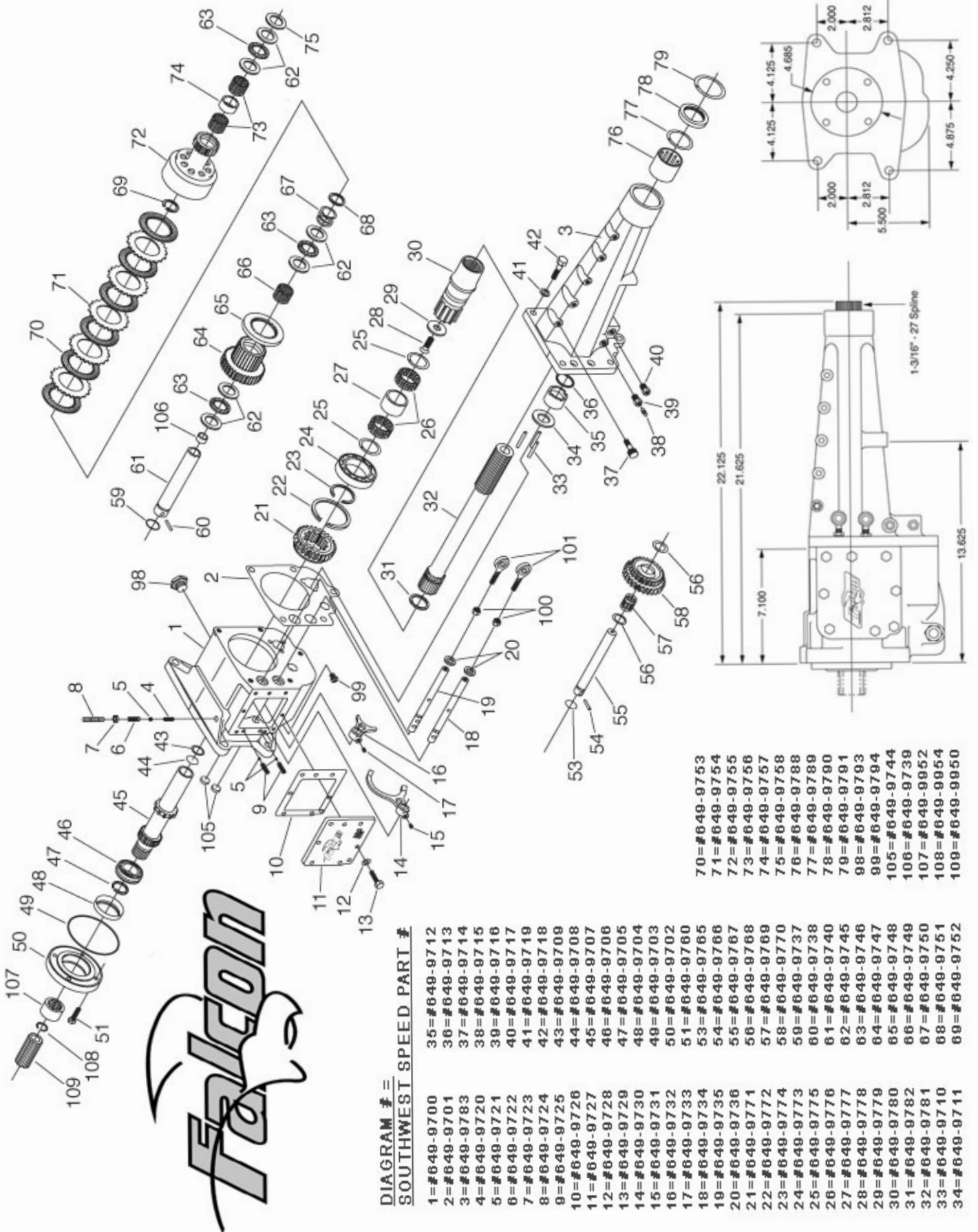

Place your order at (479) 646-6988, Fax to (479) 646-5939, or visit [www.southwestspeed.com](http://www.southwestspeed.com)



# TRANSMISSION SHIM

- ★.030" THICK SHIM CAN BE INSERTED BETWEEN THE BELLHOUSING & THE TRANSMISSION TO PROPERLY SPACE THE DRIVETRAIN IF NECESSARY
- ★WORKS WITH ALL GM TRANSMISSIONS WITH A 4.675" O.D. BEARING RETAINER

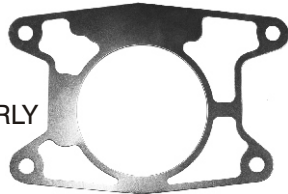

**PART #650-4010**

# TRANSMISSION STUD

- ★2 1/2" LONG STUD
- ★1/2"-13 TO 1/2"-20
- ★MAKES INSTALLATION EASIER IN CONFINED AREAS
- ★PREVENTS WEAR ON BELLHOUSING THREADS



**PART #650-4011**

# TRANSMISSION JET NUT

- ★JET NUT FOR TRANSMISSION STUDS
- ★1/2"-20 THREADS



**PART #650-4012**

# SOLID GM/CHEVY TRANSMISSION MOUNT

- ★REPLACES STOCK, OEM-STYLE, SOFT RUBBER MOUNT TO ELIMINATE LINKAGE BINDING, DRIVELINE MISALIGNMENT, & UNWANTED TRANSMISSION MOVEMENT IN RACING & STREET PERFORMANCE
- ★STURDY, SOLID MOUNT IS CONSTRUCTED FROM 3/16" STEEL & FEATURES SLOTTED HOLES ON TOP FOR TRANSMISSION MOUNTING & THREADED NUTS WELDED TO THE BOTTOM FOR CROSSMEMBER MOUNTING
- ★FOR USE ON 58-88 CHEVY, EXC. 82-92 CAMARO
- ★FITS POWERGLIDE, TH-350, TH-400, & ALL BORG-WARNER, MUNCIE, SAGINAW, CHRYSLER 4-SPD., & DOUG NASH 5-SPEED TRANSMISSIONS
- ★MUST BE USED WITH SOLID MOTOR MOUNTS (PAGE 78) TO PREVENT BREAKAGE OF TRANSMISSION CASE & ENGINE BLOCK DUE TO TORSIONAL STRESS



**PART #400-7015**

# TRANSMISSION FLUID

- ★PREMIUM QUALITY EXCEEDS PERFORMANCE REQUIREMENTS FOR MOST TRANSMISSIONS
- ★AVAILABLE FOR FORD & CHEVY



DESCRIPTION	PART #
DEXRON III FOR CHEVY (1 QUART)	940-065
TYPE F FOR FORD (1 QUART)	940-066

# SHIFTERS

- ★1, 2, & 3 LEVER SHIFTERS AVAILABLE
- ★LIGHTWEIGHT ALUMINUM SHIFTERS FEATURE A HIGH-GEAR LOCK AND COME COMPLETE WITH STRAIGHT TRANSMISSION ARMS & 3/8" RIGHT & LEFT HAND ROD ENDS

#650-420 SHOWN



#650-430

#650-460

#650-444

DESCRIPTION	PART #
1 LEVER SHIFTER KIT WITH LOCK	650-418
2 LEVER SHIFTER KIT WITH LOCK	650-420
3 LEVER SHIFTER KIT WITH LOCK	650-422
TRANSMISSION ARM ONLY - STRAIGHT	650-430
SHIFTER TUBE ONLY, 16"	650-436
SHIFTER TUBE ONLY, 24"	650-444
SHIFTER TUBE ONLY, 30"	650-450
SHIFTER TUBE ONLY, 36"	650-456
SHIFTER ARM CLEVIS ONLY	650-460
RIGHT-HAND MALE ROD END, 3/8"	103-006
LEFT-HAND MALE ROD END, 3/8"	103-016
RIGHT-HAND JAM NUT, 3/8"	102-936
LEFT-HAND JAM NUT, 3/8"	102-946

# TRANSMISSION STAND

- ★FITS BRINN, BERT, FALCON, MUNCIE, T-10, & OTHER SIMILAR TRANSMISSIONS
- ★LIGHTWEIGHT STEEL CONSTRUCTION



**PART #650-805**

# TRANSMISSION TREATMENT AUTOMATIC



- ★ELIMINATES FLUID FOAMING
- ★FREES STICKING VALVE BODIES
- ★IMPROVES SHIFTING
- ★COOLS TRANSMISSION FLUID
- ★INCREASES TRANSMISSION LIFE
- ★COMES IN 12 OZ. PLASTIC BOTTLE

**PART #PBM 4000**

# MANUAL

- ★INSTANTLY COOLS GEAR LUBE UP TO 60 DEGREES
- ★ELIMINATES NOISE, HEAT, AND WEAR
- ★IMPROVES SHIFTING
- ★DO NOT MIX WITH POSI-LUBE
- ★COMES IN 12 OZ. PLASTIC BOTTLE



**PART #PBM 8888**

Place your order at (479) 646-6988, Fax to (479) 646-5939, or visit [www.southwestspeed.com](http://www.southwestspeed.com)

# SOUTHWEST SPEED RACING DRIVESHAFTS

- ★PRECISION BALANCED; EACH DRIVESHAFT COMES WITH A NEW 27 SPLINE YOKE & NEW 1310 SERIES (1 1/16" x 3 7/32") U-JOINTS
- ★THEY CAN BE SUPPLIED WITH A DIFFERENT SLIP YOKE AT AN ADDITIONAL COST UPON REQUEST
- ★THERE ARE ALSO SEVERAL CONVERSION U-JOINTS AVAILABLE TO CONVERT THESE 1310 SHAFTS TO OTHER SERIES OF PINION YOKE
- ★ALL YOKES & U-JOINTS ARE LISTED ON PAGE 150
- ★ALL DRIVESHAFTS ARE MEASURED CENTER-OF-U-JOINT TO CENTER-OF-U-JOINT (shown below)



← LENGTH: CENTER U-JOINT TO CENTER U-JOINT →

- ★IF YOUR OLD DRIVESHAFT ISN'T AVAILABLE OR THIS SHAFT WILL BE INSTALLED IN A NEW CAR, YOU CAN USE THIS METHOD:
- \*"A" - MEASURE FROM THE REAR OF THE TAILHOUSING TO THE FRONT OF THE REAR END PINION YOKE (shown below)
- \*THIS MEASUREMENT NEEDS TO BE TAKEN WITH THE CAR AT RIDE HEIGHT, YOU CAN'T GET A PROPER MEASUREMENT WITH THE CAR JACKED UP IN ANY WAY
- \*IF YOU USE THIS METHOD TO DETERMINE THE LENGTH, MAKE SURE TO LET US KNOW WHEN YOU ORDER & WE CAN

DETERMINE WHICH LENGTH, CENTER-TO-CENTER, YOU ACTUALLY NEED

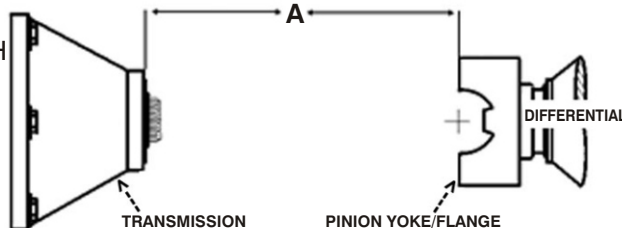

## STEEL DRIVESHAFTS - 2" & 2 1/2" O.D.



- ★2" O.D. & 2 1/2" O.D. SHAFTS AVAILABLE
- ★LIGHTWEIGHT STEEL CONSTRUCTION, PAINTED WHITE
- ★WITH THE 2 1/2" SERIES DRIVESHAFTS, AS THEY GET LONGER, LARGER TUBING IS REQUIRED; AT 50", THEY STEP UP TO 2 3/4" O.D.; AT 58", THEY STEP UP TO 3" O.D.; AT 60 1/2", THEY STEP UP TO 3 1/2" O.D.

## ALUMINUM DRIVESHAFTS - 3" O.D.



- ★WEIGHS 40% LESS THAN 2 1/2" STEEL SHAFTS

NOTE: ALUMINUM DRIVESHAFTS ON RACE CARS THAT REGULARLY RUN ON 3 WHEELS MUST HAVE THE YOKE CLEARANCED FOR PROPER TRAVEL OR THE DRIVESHAFT WILL BE DAMAGED.

## DRIVESHAFT LOOPS

- ★HELP CONTAIN DRIVESHAFT IN THE CASE OF FAILURE

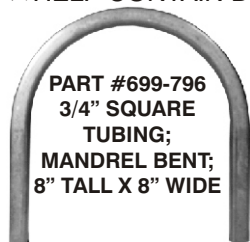

PART #699-796  
3/4" SQUARE TUBING;  
MANDREL BENT;  
8" TALL X 8" WIDE



PART #PCE 3931  
3/16" THICK STEEL;

HAS SEVERAL HOLES FOR ADJUSTMENT;  
INCLUDES HARDWARE; GREAT FOR DRAG RACING;

C-C LENGTH	2" STEEL	2 1/2" STEEL	3" ALUM.
25"	699-4988	-	-
25 1/2"	699-4989	-	-
26"	699-499	-	-
26 1/2"	699-500	-	-
27"	699-501	699-901	699-802
27 1/2"	699-502	699-902	699-803
28"	699-503	699-903	699-804
28 1/2"	699-504	699-904	699-805
29"	699-506	699-906	699-806
29 1/2"	699-508	699-908	699-808
30"	699-510	699-910	699-810
30 1/2"	699-512	699-912	699-812
31"	699-514	699-914	699-814
31 1/2"	699-516	699-916	699-816
32"	699-518	699-918	699-818
32 1/2"	699-520	699-920	699-820
33"	699-522	699-922	699-822
33 1/2"	699-524	699-924	699-824
34"	699-526	699-926	699-826
34 1/2"	699-528	699-928	699-828
35"	699-530	699-930	699-830
35 1/2"	699-532	699-932	699-832
36"	699-534	699-934	699-834
36 1/2"	699-536	699-936	699-836
37"	699-538	699-938	699-838
37 1/2"	699-540	699-940	699-840
38"	699-542	699-942	699-842
38 1/2"	699-544	699-944	699-844
39"	699-546	699-946	699-846
39 1/2"	699-548	699-948	699-848
40"	699-550	699-950	699-850
40 1/2"	699-552	699-952	699-852
41"	699-554	699-954	699-854
41 1/2"	699-556	699-956	699-856
42"	699-558	699-958	699-858
42 1/2"	699-560	699-960	699-860
43"	699-562	699-962	699-862
43 1/2"	699-564	699-964	699-864
44"	699-566	699-966	699-866
44 1/2"	699-568	699-968	699-868
45"	699-570	699-970	699-870
45 1/2"	-	699-972	699-872
46"	-	699-974	699-874
46 1/2"	-	699-976	699-876
47"	-	699-978	699-878
47 1/2"	-	699-980	699-880
48"	-	699-982	699-882
48 1/2"	-	699-984	699-884
49"	-	699-986	699-886
49 1/2"	-	699-988	699-888
50"	-	699-990	699-890
50 1/2"	-	699-992	699-892
51"	-	699-994	699-894
51 1/2"	-	699-995	699-895
52"	-	699-996	699-896
52 1/2"	-	699-997	-
C-C LENGTH	2 1/2" STEEL	C-C LENGTH	2 1/2" STEEL
53"	699-998	58 1/2"	699-9991
53 1/2"	699-9981	59"	699-9992
54"	699-9982	59 1/2"	699-9993
54 1/2"	699-9983	60"	699-9994
55"	699-9984	60 1/2"	699-9995
55 1/2"	699-9985	61"	699-9996
56"	699-9986	61 1/2"	699-9997
56 1/2"	699-9987	62"	699-9998
57"	699-9988	62 1/2"	699-9999
57 1/2"	699-9989	63"	700-0000
58"	699-9990		

Place your order at (479) 646-6988, Fax to (479) 646-5939, or visit [www.southwestspeed.com](http://www.southwestspeed.com)

# DRIVESHAFT UNIVERSAL JOINTS

★HIGH QUALITY U-JOINTS WITH NEEDLE BEARING CAPS; EACH INCLUDES SNAP RINGS & GREASE FITTING  
 ★"SIDE 1" & "SIDE 2" ARE ONLY USED FOR DESCRIPTION, THE U-JOINTS CAN BE USED EITHER WAY

U-JOINT SERIES BREAKDOWN				
SERIES	CUP O.D.	WIDTH	CLIPS	INT. CLIP WIDTH
1310	1 1/16"	3 7/32"	EXT.	
1310SP	1 1/8"	3 7/32"	EXT.	
1330	1 1/16"	3 5/8"	EXT.	
1330SP	1 1/8"	3 5/8"	EXT.	
1350	1 3/16"	3 5/8"	EXT.	
3R / S44	1 1/8"	3 5/8"	INT.	2 9/16"
7260	1 5/64"	3 7/32"	INT.	2 1/8"
7290	1 1/8"	3 5/8"	INT.	2 5/8"
1000	1 5/16"	-	INT.	1 1/2"
1410	1 3/16"	4 3/16"	EXT.	
1480	1 3/8"	4 3/16"	EXT.	
1550	1 3/8"	4 31/32"	EXT.	
L6	31/32"	-	INT.	1 7/16"
P55	1 1/16"	3 5/8"	INT.	2 25/32"
R55	1 1/16"	-	INT.	2 9/16"
S55	1 1/8"	3 7/32"	INT.	2 3/8"

CONVERSION U-JOINT SERIES	SIDE 1			SIDE 2			PART #
	CUP O.D.	WIDTH	CLIPS	CUP O.D.	WIDTH	CLIPS	
1310 - 1310	1 1/16"	3 7/32"	EXT.	1 1/16"	3 7/32"	EXT.	699-780
1310 - 1330	1 1/16"	3 7/32"	EXT.	1 1/16"	3 5/8"	EXT.	699-782
1310 - 1310SP	1 1/16"	3 7/32"	EXT.	1 1/8"	3 7/32"	EXT.	699-7862
1310 - 1330SP	1 1/16"	3 7/32"	EXT.	1 1/8"	3 5/8"	EXT.	699-784
1310 - 1350	1 1/16"	3 7/32"	EXT.	1 3/16"	3 5/8"	EXT.	699-788
1310 - 3R	1 1/16"	3 7/32"	EXT.	1 1/8"	3 5/8"	INT. (2 9/16")	699-7802
1310 - 7260	1 1/16"	3 7/32"	EXT.	1 5/64"	3 7/32"	INT. (2 1/8")	699-7886
1330 - 1330	1 1/16"	3 5/8"	EXT.	1 1/16"	3 5/8"	EXT.	699-7883
1330 - 1350	1 1/16"	3 5/8"	EXT.	1 3/16"	3 5/8"	EXT.	699-7884
1330 - 3R	1 1/16"	3 5/8"	EXT.	1 1/8"	3 5/8"	INT. (2 9/16")	699-7885
1330 - 7260	1 1/16"	3 5/8"	EXT.	1 5/64"	3 7/32"	INT. (2 1/8")	699-7887
1330SP - 3R	1 1/8"	3 5/8"	EXT.	1 1/8"	3 5/8"	INT. (2 9/16")	699-7889
1350 - 1350	1 3/16"	3 5/8"	EXT.	1 3/16"	3 5/8"	EXT.	699-7894
3R - 3R	1 1/8"	3 5/8"	INT. (2 9/16")	1 1/8"	3 5/8"	INT. (2 9/16")	699-7895
1410 - 1410	1 3/16"	4 3/16"	EXT.	1 3/16"	4 3/16"	EXT.	699-7896
1480 - 1480	1 3/8"	4 3/16"	EXT.	1 3/8"	4 3/16"	EXT.	699-7897
7260 - 7260	1 5/64"	3 7/32"	INT. (2 1/8")	1 5/64"	3 7/32"	INT. (2 1/8")	699-7898
7260 - 7290	1 5/64"	3 7/32"	INT. (2 1/8")	1 1/8"	3 5/8"	INT. (2 5/8")	699-7900
7290 - 7290	1 1/8"	3 5/8"	INT. (2 5/8")	1 1/8"	3 5/8"	INT. (2 5/8")	699-7899
P55 - P55	1 1/16"	3 5/8"	INT. (2 25/32")	1 1/16"	3 5/8"	INT. (2 25/32")	699-7902
R55 - R55	1 1/16"	-	INT. (2 9/16")	1 1/16"	-	INT. (2 9/16")	699-7903
S55 - S55	1 1/16"	3 7/32"	INT. (2 3/8")	1 1/16"	3 7/32"	INT. (2 3/8")	699-7904
-	1 1/8"	3 7/32"	EXT.	1 1/16"	3 7/32"	INT. (2 7/16")	699-786

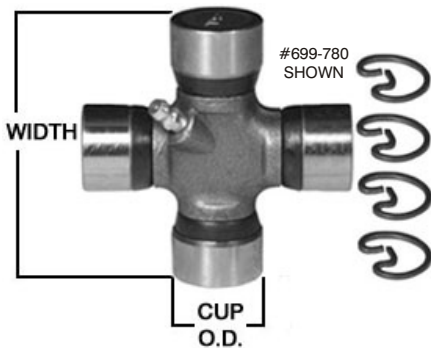

## DRIVESHAFT SLIP YOKES

★BRAND NEW 27, 28, 31, & 32 SPLINE YOKES AVAILABLE TO FIT SEVERAL DIFFERENT SERIES OF U-JOINTS

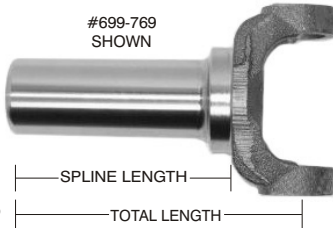

## POPULAR EXTRA-LONG RACING YOKE



★6 1/2" SPLINE LENGTH & 8" TOTAL LENGTH PROVIDES MORE TRAVEL THAT IS OFTEN NECESSARY IN RACING APPLICATIONS

YOKES SPLINE	U-JOINT SERIES	U-JOINT CUP O.D.	U-JOINT WIDTH	U-JOINT CLIPS	SPLINE LENGTH	TOTAL LENGTH*	PART #
27 SPLINE	1310	1 1/16"	3 7/32"	EXT.	4 1/2"	5 1/2"	699-769
27 SPLINE	1310	1 1/16"	3 7/32"	EXT.	6 1/2"	8"	699-770
27 SPLINE	1330	1 1/16"	3 5/8"	EXT.	4 1/8"	5 1/2"	699-7671
27 SPLINE	1330	1 1/16"	3 5/8"	EXT.	6 1/2"	8"	699-7675
27 SPLINE	1350	1 3/16"	3 5/8"	EXT.	4 3/8"	5 1/2"	699-7679
27 SPLINE	1350	1 3/16"	3 5/8"	EXT.	5 3/4"	7"	699-7680
27 SPLINE	3R	1 1/8"	3 5/8"	INT.	4 1/2"	5 1/2"	699-7660
27 SPLINE	3R	1 1/8"	3 5/8"	INT.	6 1/4"	8"	699-7666
28 SPLINE	1310	1 1/16"	3 7/32"	EXT.	5 5/8"	6 1/2"	699-7692
28 SPLINE	1330	1 1/16"	3 5/8"	EXT.	5 1/16"	6"	699-7672
28 SPLINE	1350	1 3/16"	3 5/8"	EXT.	4 3/4"	6 1/2"	699-7681
31 SPLINE	1310	1 1/16"	3 7/32"	EXT.	4 1/2"	5 1/2"	699-7694
31 SPLINE	1330	1 1/16"	3 5/8"	EXT.	4 7/8"	6"	699-7677
31 SPLINE	1350	1 3/16"	3 5/8"	EXT.	4 1/4"	6"	699-7682
32 SPLINE	1310	1 1/16"	3 7/32"	EXT.	4 1/2"	5 1/2"	699-7698
32 SPLINE	1330	1 1/16"	3 5/8"	EXT.	6 1/8"	7 1/2"	699-7678
32 SPLINE	1350	1 3/16"	3 5/8"	EXT.	4 1/4"	5 5/8"	699-7685
32 SPLINE	3R	1 1/8"	3 5/8"	INT.	6 1/4"	7 1/2"	699-7665

\*TOTAL LENGTH IS MEASURED FROM THE CENTER OF THE U-JOINT TO THE END OF THE YOKE

27 SPLINE	BERT, BRINN, FALCON, GM POWERGLIDE, SAGINAW 3 SPEED & 4 SPEED, MUNCIE 4 SPEED, BORG WARNER T-4, BORG WARNER GM T-5, GM T-350, GM TH-350, GM T-56, 200R 200-4R, 700R, 700R4, 4L60, 4L60E, 4L65E, 4L70E, 4LL0E, 200 METRIC, & OTHERS
32 SPLINE	GM T-400, GM TH-400, RICHMOND SUPER T-10 4 SPEED, MUNCIE M21 4 SPEED, MUNCIE M22 ROCKCRUSHER 4 SPEED, DOUG NASH, JERICO, 4L80E, 4L85E, & ALL BORG WARNER, EXCEPT T-4 & T-5
28 SPLINE	FORD C-4, FORD TOPLOADER, FORD AOD, & FORD BORG WARNER/TREMEC T-5
31 SPLINE	FORD C-6, FORD T-56, FORD 4R100, TREMEC T-45, TKO600, 3650 TKO, & FMX

## DRIVESHAFT U-BOLTS

★AVAILABLE FOR 1 1/16" & 1 1/8" O.D. U-JOINT CUPS  
 ★EACH SET INCLUDES 2 U-BOLTS, 4 NUTS, & 4 LOCK WASHERS



DESCRIPTION	PART #
DRIVESHAFT U-BOLT KIT, 1-1/16" O.D.	699-905
DRIVESHAFT U-BOLT KIT, 1-1/8" O.D.	699-907

## U-JOINT GIRDLES

★PREVENTS U-JOINT CAP DISTORTION, WHICH IS COMMON WITH OVERTIGHTENING U-BOLTS  
 ★UNIQUE DESIGN PROVIDES MORE BEARING SURFACE FOR THE U-JOINT CAP ADDING STRENGTH  
 ★FITS 1 1/16" O.D. CUPS  
 ★1 SET (2 PIECES) PER PACK



PART #699-900

Place your order at (479) 646-6988, Fax to (479) 646-5939, or visit [www.southwestspeed.com](http://www.southwestspeed.com)



# QUICK CHANGE REAR ENDS

- ★ QUICK CHANGE REAR ENDS AVAILABLE FOR MODIFIED, LATE MODEL, LEGEND, DWARF, & BABY GRAND CLOSED TUBE APPLICATIONS, AND, SPRINT CAR & MIDGET OPEN TUBE, ALL IN SEVERAL DIFFERENT CONFIGURATIONS
- ★ WE ALSO HAVE WINTERS STREET ROD REAR ENDS; CHECK [southwestspeed.com](http://southwestspeed.com) TO SEE THOSE
- ★ TAKES 10" RING GEAR, UNLESS NOTED
- ★ EACH REAR END COMES COMPLETE WITH 4.86 RING & PINION, SPOOL, AND TUBES/LIVE AXLE
- ★ REARS DON'T INCLUDE THE SPUR GEARS

DESCRIPTION	TUBES	PART #
ALUMINUM QC REAR END, 4.86	STEEL	604-300
ALUMINUM QC REAR END, 4.11	STEEL	604-3002
MAGNESIUM QC REAR END, 4.86	STEEL	604-326
TIGER MAG LOW DRAG QC REAR END, 4.86	STEEL	604-3023
MAGNESIUM QC REAR END, 4.11	STEEL	604-3262
MAGNESIUM QC REAR END, 8 3/8", 4.11	STEEL	604-3282
MAGNESIUM QC REAR END, 4.86, G	ALUMINUM	604-3302
MAGNESIUM QC REAR END, 4.86, R&W	ALUMINUM	604-3312
TOYOTA/LEGENDS ALUM QC, 7", 3.78	STEEL	604-3036
BABY GRAND MAG MINI QC, 8 3/8", 3.78	STEEL	604-3039
SPRINT CAR MAG PRO ELIM. QC, 4.86	ALUM LIVE AXLE	604-3520
SPRINT CAR MAG PRO ELIM. QC, 4.11	ALUM LIVE AXLE	604-3522
MIDGET MAG QC, 8 3/8", 3.78, ALUM COUP.	ALUM LIVE AXLE	604-3720
MIDGET MAG QC, 8 3/8", 3.78, STEEL COUP.	ALUM LIVE AXLE	604-3721

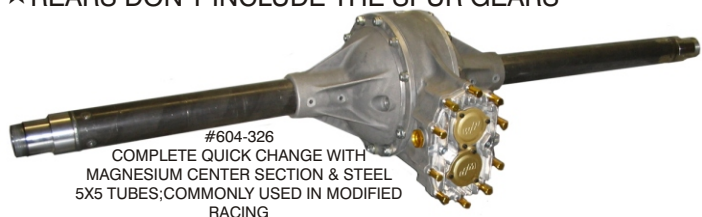

#604-326  
COMPLETE QUICK CHANGE WITH MAGNESIUM CENTER SECTION & STEEL 5X5 TUBES; COMMONLY USED IN MODIFIED RACING



#604-3036  
TOYOTA/DWARF/LEGENDS REAR END WITH 4 BOLT TOYOTA FLANGES ON THE ENDS WINTERS 7", 3.78 R&P; USES 6 SPLINE Q.C. GEARS



#604-3520  
SPRINT CAR MAGNESIUM PRO ELIMINATOR QUICK CHANGE WITH LIGHTWEIGHT ALUMINUM 42 SPLINE LIVE AXLE, 10" 4.86 R&P, & STEEL INTERNAL COUPLER

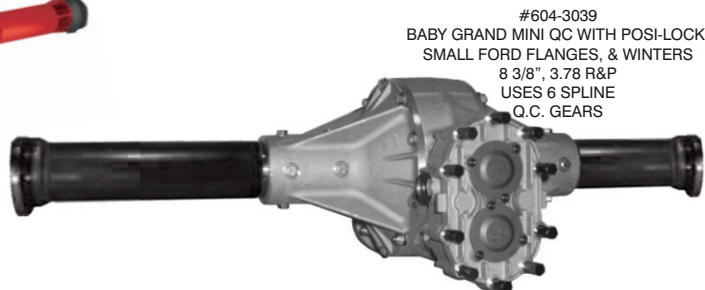

#604-3039  
BABY GRAND MINI QC WITH POSI-LOCK, SMALL FORD FLANGES, & WINTERS 8 3/8", 3.78 R&P USES 6 SPLINE Q.C. GEARS

## QUICK CHANGE 10" RING & PINIONS

- ★ TOUGH, 9310 HIGH NICKEL ALLOY CONSTRUCTION
- ★ HEAT-TREATED, PRECISION MATCHED SETS
- ★ 10 SPLINE PINION SHAFTS
- ★ FITS ALL POPULAR QUICK CHANGE REAR ENDS
- ★ 4.11 & 4.86 AVAILABLE IN BOTH LIGHTWEIGHT & STANDARD WEIGHT, AS WELL AS LOADED WITH BEARINGS & POSI-LOC NUT ASSEMBLY



#604-120

#604-122

DESCRIPTION	PART #
Q.C. RING & PINION, 4.11	604-119
Q.C. RING & PINION, 4.11, L.W.	604-1192
Q.C. RING & PINION, 4.11, LOADED	604-121
Q.C. RING & PINION, 4.11, LOADED, L.W.	604-1212
Q.C. RING & PINION, 4.86	604-120
Q.C. RING & PINION, 4.86, LOADED	604-122

## Q.C. SPUR GEAR SETS

- ★ SEE PAGE 153 FOR COMPLETE SELECTION OF SPUR GEAR SETS IN BOTH BLACK MAGIC & SCS GEARBOX BRANDS



## QUICK CHANGE YOKES

- ★ AVAILABLE IN 4340 FORGED STEEL & 7075-T6 LIGHTWEIGHT ALUMINUM
- ★ YOKES ACCEPT 1310 SERIES (1 1/16" CUP O.D. x 3 7/32" WIDE) U-JOINTS



#604-236



#604-238

DESCRIPTION	PART #
Q.C. DRIVESHAFT YOKE, STEEL	604-236
Q.C. DRIVESHAFT YOKE, ALUMINUM	604-238

## DRAIN PAN/GEAR TRAY

- ★ LIGHTWEIGHT ALUMINUM GEAR TRAY, FEATURING A POURING SPOUT

PART #600-045

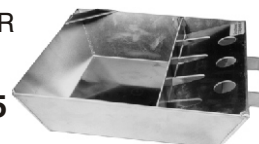

## GEAR STORAGE BOX

- ★ PROTECTS & STORES 1 SET OF QC GEARS
- ★ DURABLE CLEAR PLASTIC GEAR CASE
- ★ PROTECTS GEARS
- ★ IDENTIFYING LABEL INCLUDED
- ★ SEE PAGE 153 FOR THE COMPLETE SELECTION OF Q.C. GEAR SETS

PART

#604-001



Place your order at (479) 646-6988, Fax to (479) 646-5939, or visit [www.southwestspeed.com](http://www.southwestspeed.com)

# QUICK CHANGE REAR END DIAGRAM

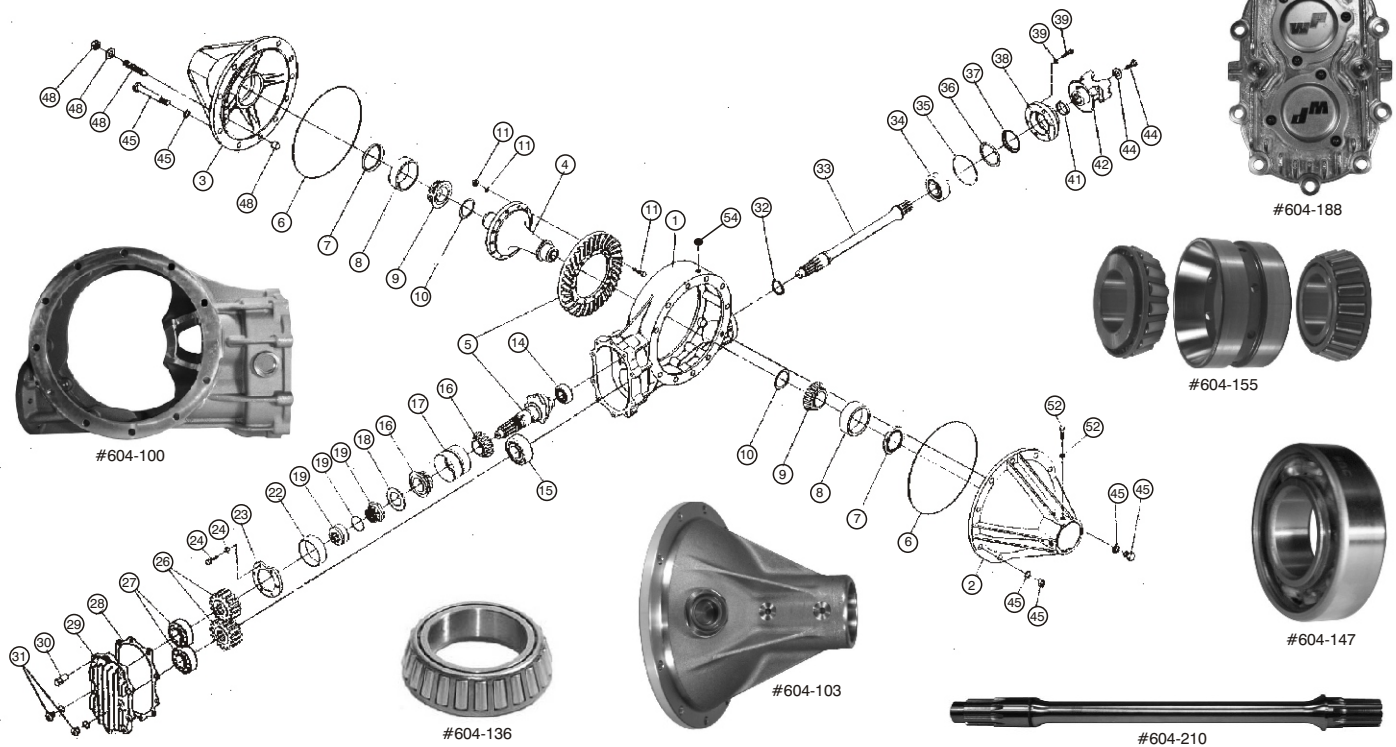

REF	DESCRIPTION	PART #
	Q.C. OVERHAUL KIT (ALL EXCEPT WINTERS)**	604-289
	Q.C. OVERHAUL KIT (FOR WINTERS)**	604-2889
1	ALUMINUM SPRINT CENTER SECTION	604-100
1	MAG. SPRINT CENTER SECTION	604-101
2	ALUM., RIGHT SIDE BELL, 6 RIB W/ PLUG	604-103
2	MAG. RIGHT SIDE BELL	604-104
3	ALUMINUM, LEFT SIDE BELL, 6 RIB	604-107
3	MAG. LEFT SIDE BELL	604-108
4	ALUM FULL SPOOL,31 SP.(ALL EXC. WINTERS)	604-051
4	ALUM FULL SPOOL,31 SPLINE (WINTERS)	604-053
5	RING & PINION (SEE PAGE 151)	-
6	O-RING, SIDE BELL	604-130
7	SPOOL SEAL, SIDE BELL	604-133
	SIDE BELL SEAL INSTALLATION TOOL	789-760
8	BEARING RACE, SIDE BELL	604-135
9	BEARING (ALL EXC. WINTERS ALUM.)	604-136
9	BEARING (WINTERS ALUMINUM)	604-137
10	SHIM KIT, SET UP	604-140
11	RING GEAR BOLT & NUT SET	604-142
11	RING GEAR BOLT SET, THREADED R&P	604-144
14	PINION NOSE, BALL BEARING	604-147
14	PINION NOSE, ROLLER BEARING	604-148
14	PINION NOSE, DOUBLE BEARING	604-149
15	REAR LOWER SHAFT BEARING	604-150
15	REAR LOWER SHAFT BEARING, SHIELDED	604-220
15	REAR LOW. SHAFT BEAR.,DOUBLE,SHIELD	604-219
16	BEARING, PINION SHAFT	604-152
17	DOUBLE BEARING RACE, PINION SHAFT	604-154
17	PINION BEARING SET, PRELOADED	604-155
19	PINION NUT TANG LOCK	604-157
18	BEARING WASHER, PINION SHAFT	604-158
19	PINION NUT, RIGHT THREAD, THIN	604-159
19	PINION NUT ASSEMBLY, RIGHT, POSI	604-160
19	PINION NUT ASSEMBLY, LEFT, POSI	604-161
19	PINION NUT, LEFT THREAD	604-162
	UPPER GEAR SPACER	604-168
22	RETAINING RING, PINION	604-170
23	RETAINING PLATE, PINION	604-172
24	RETAINING PLATE BOLT SET, PINION	604-174
	RETAINING PLATE LOCKING TABS	604-175

REF	DESCRIPTION	PART #
26	QUICK CHANGE GEAR SET (SEE PG. 153)	-
27	GEAR COVER BEARING, SPRINT, SINGLE	604-178
27	GEAR COVER BEARING, SPRINT, DOUBLE	604-180
28	GEAR COVER GASKET, SPRINT	604-182
28	GEAR COVER GASKET, MIDGET	604-482
29	ALUM. GEAR COVER, COMPLETE SPRINT	604-188
29	MAG. GEAR COVER, COMPLETE SPRINT	604-191
29	GEAR COVER BEARING CAP	604-192
29	GEAR COVER BEARING CAP O-RING	604-193
30	GEAR COVER HIGH NUT SET, STEEL	604-194
30	GEAR COVER HIGH NUT SET, ALUMINUM	604-195
30	GEAR COVER NUT & STUD SET, ALUM.	604-196
	INSPECTION PLUG WITH O-RING	604-197
31	#6 AN PORT PLUG & O-RING, EACH	604-198
32	SNAP RING, LOWER SHAFT	604-200
33	HEAT TREATED LOWER SHAFT	604-210
34	BEARING, LOWER SHAFT, FRONT	604-218
35	O-RING, SEAL PLATE	604-222
36	FRONT SEAL SNAP RING (HAWK)	604-223
36	SNAP RING, SEAL PLATE	604-224
37	FRONT YOKE SEAL, WINTERS	604-226
37	FRONT YOKE SEAL, HD FELT TYPE	604-228
38	SEAL PLATE WITH SEAL	604-230
39	SEAL PLATE BOLT KIT	604-232
41	SPACER, FRONT YOKE	604-234
42	FRONT YOKE, STEEL	604-236
42	FRONT YOKE, BILLET ALUMINUM	604-238
44	FRONT YOKE BOLT & HD WASHER	604-245
45	SIDE BELL THRU BOLT & NUT SET	604-247
48	THRUST BLOCK & ADJUSTER ASSY.	604-260
52	SIDE TUBE BOLT SET, 1 SIDE	604-265
54	3/8" PIPE PLUG	604-266

\*\*#604-289 COMPLETE OVERHAUL KIT IS FOR ALL QUICKCHANGES EXCEPT THE WINTERS. #604-2889 IS FOR THE WINTERS ONLY. EACH KIT INCLUDES 1 SEAL PLATE O-RING, 1 YOKE SEAL, 2 SIDE BELL O-RINGS, 2 INBOARD SEALS, 22 THROUGH BOLT HEAT TREATED WASHERS, 2 CARRIER BEARING RACES, 2 CARRIER BEARINGS, 1 ASSORTED SHIM KIT, 2 GEAR COVER BEARINGS, 1 PINION BEARING DUAL RACE, 2 PINION BEARINGS, 1 PINION NOSE BEARING, AND 2 LOWER SHAFT BEARINGS (FRONT & REAR)

Place your order at (479) 646-6988, Fax to (479) 646-5939, or visit [www.southwestspeed.com](http://www.southwestspeed.com)



# QUICK CHANGE 10 SPLINE SPUR GEAR SETS

## Black Magic

- ★ PREMIUM QUALITY, BLACK MAGIC GEARS BY SOUTHWEST SPEED
- ★ 10 SPLINE
- ★ ALL GEARS COME WITH HARD PLASTIC STORAGE BOX
- ★ TO FIGURE EXACT GEAR RATIO, 1ST GET THE SPUR RATIO:  
\*SPUR RATIO=TEETH ON TOP GEAR DIVIDED BY TEETH ON BOTTOM GEAR
- ★ THEN FIGURE THE GEAR RATIO:  
\*GEAR RATIO=SPUR RATIO x RING & PINION RATIO



BLACK MAGIC SPUR GEARS		4.11 R&P		4.86 R&P	
Part #	Teeth	Low Ratio	High Ratio	Low Ratio	High Ratio
604-501	23 / 23	4.11	4.11	4.86	4.86
604-502	27 / 28	4.26	3.96	5.04	4.69
604-505	24 / 25	4.28	3.95	5.06	4.67
604-515	19 / 20	4.33	3.90	5.12	4.62
604-5151	17 / 18	4.35	3.88	5.15	4.59
604-5261	27 / 29	4.41	3.83	5.22	4.52
604-526	25 / 27	4.44	3.81	5.25	4.50
604-506	23 / 25	4.47	3.78	5.28	4.47
604-525	20 / 22	4.52	3.74	5.35	4.42
604-5121	26 / 29	4.58	3.68	5.42	4.36
604-512	24 / 27	4.62	3.65	5.47	4.32
604-507	23 / 26	4.65	3.64	5.49	4.30
604-5071	21 / 24	4.70	3.60	5.55	4.25
604-5171	20 / 23	4.73	3.57	5.59	4.23
604-517	25 / 29	4.77	3.54	5.64	4.19
604-5081	23 / 27	4.82	3.50	5.71	4.14
604-508	22 / 26	4.86	3.48	5.74	4.11
604-519	21 / 25	4.89	3.45	5.79	4.08
604-5091	20 / 24	4.93	3.43	5.83	4.05
604-509	19 / 23	4.98	3.40	5.88	4.01
604-511	18 / 22	5.02	3.36	5.94	3.98
604-5111	22 / 27	5.04	3.35	5.96	3.96
604-503	25 / 31	5.10	3.31	6.03	3.92
604-513	20 / 25	5.14	3.29	6.08	3.89
604-518	23 / 29	5.18	3.26	6.13	3.85
604-5181	22 / 28	5.23	3.23	6.19	3.82
604-5041	18 / 23	5.25	3.22	6.21	3.80
604-5201	21 / 27	5.28	3.20	6.25	3.78
604-504	24 / 31	5.31	3.18	6.28	3.76
604-520	20 / 26	5.34	3.16	6.32	3.74
604-522	19 / 25	5.41	3.12	6.39	3.69
604-516	18 / 24	5.48	3.08	6.48	3.65

BLACK MAGIC SPUR GEARS		4.11 R&P		4.86 R&P	
Part #	Teeth	Low Ratio	High Ratio	Low Ratio	High Ratio
604-510	17 / 23	5.56	3.04	6.58	3.59
604-5101	22 / 30	5.60	3.01	6.63	3.56
604-534	16 / 22	5.65	2.99	6.68	3.53
604-5341	21 / 29	5.68	2.98	6.71	3.52
604-514	23 / 32	5.72	2.95	6.76	3.49
604-5141	20 / 28	5.75	2.94	6.80	3.47
604-535	17 / 24	5.80	2.91	6.86	3.44
604-532	19 / 27	5.84	2.89	6.91	3.42
604-5351	21 / 30	5.87	2.88	6.94	3.40
604-5321	16 / 23	5.91	2.86	6.99	3.38
604-524	20 / 29	5.96	2.83	7.05	3.35
604-536	17 / 25	6.04	2.79	7.15	3.30
604-537	21 / 31	6.07	2.78	7.17	3.29
604-523	16 / 24	6.17	2.74	7.29	3.24
604-521	21 / 32	6.26	2.70	7.41	3.19
604-5211	15 / 23	6.30	2.68	7.45	3.17
604-527	22 / 34	6.35	2.66	7.51	3.14
604-543	16 / 25	6.42	2.63	7.59	3.11
604-528	19 / 30	6.49	2.60	7.67	3.08
604-5281	17 / 27	6.53	2.59	7.72	3.06
604-529	15 / 24	6.58	2.57	7.78	3.04
604-539	18 / 29	6.62	2.55	7.83	3.02
604-530	16 / 26	6.68	2.53	7.90	2.99
604-540	19 / 31	6.71	2.52	7.93	2.98
604-541	17 / 28	6.77	2.50	8.00	2.95
604-531	18 / 30	6.85	2.47	8.10	2.92
604-5331	16 / 27	6.94	2.44	8.20	2.88
604-533	20 / 34	6.99	2.42	8.26	2.86
604-5311	14 / 24	7.05	2.40	8.33	2.84
604-5301	15 / 26	7.12	2.37	8.42	2.80
604-5501	16 / 28	7.19	2.35	8.51	2.78

## SCS GEARBOX

- ★ SCS GEARBOX INC. SPUR GEARS ARE CNC CROWN HOBBED TO PRODUCE THE HIGHEST QUALITY ON THE MARKET
- ★ HEAT-TREATED, 8620 STEEL CONSTRUCTION
- ★ GEARS FEATURE A REM FINISH



SCS GEARBOX INC. SPUR GEARS		4.11 R&P		4.86 R&P	
Part #	Teeth	Low Ratio	High Ratio	Low Ratio	High Ratio
SCS S-01	21 / 21	4.11	4.11	4.86	4.86
SCS S-02	27 / 28	4.26	3.96	5.04	4.69
SCS S-05	24 / 25	4.28	3.95	5.06	4.67
SCS S-15	19 / 20	4.33	3.90	5.12	4.62
SCS S-15K	15 / 16	4.38	3.85	5.18	4.56
SCS S-26	27 / 29	4.41	3.83	5.22	4.52
SCS S-06	23 / 25	4.47	3.78	5.28	4.47
SCS S-25	20 / 22	4.52	3.74	5.35	4.42
SCS S-12	26 / 29	4.58	3.68	5.42	4.36
SCS S-07	23 / 26	4.65	3.64	5.49	4.30
SCS S-07K	21 / 24	4.70	3.60	5.55	4.25
SCS S-17	19 / 22	4.76	3.55	5.63	4.20
SCS S-08K	17 / 20	4.84	3.49	5.72	4.13
SCS S-08	22 / 26	4.86	3.48	5.74	4.11
SCS S-19	21 / 25	4.89	3.45	5.79	4.08
SCS S-09K	25 / 30	4.93	3.43	5.83	4.05
SCS S-09	19 / 23	4.98	3.40	5.88	4.01
SCS S-11	22 / 27	5.04	3.35	5.96	3.96
SCS S-03	25 / 31	5.10	3.31	6.03	3.92
SCS S-13	20 / 25	5.14	3.29	6.08	3.89
SCS S-18	19 / 24	5.19	3.25	6.14	3.85
SCS S-04K	18 / 23	5.25	3.22	6.21	3.80
SCS S-04	24 / 31	5.31	3.18	6.28	3.76
SCS S-20	20 / 26	5.34	3.16	6.32	3.74

SCS GEARBOX INC. SPUR GEARS		4.11 R&P		4.86 R&P	
Part #	Teeth	Low Ratio	High Ratio	Low Ratio	High Ratio
SCS S-22	19 / 25	5.41	3.12	6.39	3.69
SCS S-16	24 / 32	5.48	3.08	6.48	3.65
SCS S-10	20 / 27	5.55	3.04	6.56	3.60
SCS S-34	19 / 26	5.62	3.00	6.65	3.55
SCS S-14	23 / 32	5.72	2.95	6.76	3.49
SCS S-14K	20 / 28	5.75	2.94	6.80	3.47
SCS S-35	17 / 24	5.80	2.91	6.86	3.44
SCS S-32K	23 / 33	5.90	2.86	6.97	3.39
SCS S-24	20 / 29	5.96	2.83	7.05	3.35
SCS S-36	17 / 25	6.04	2.79	7.15	3.30
SCS S-37	23 / 34	6.08	2.78	7.18	3.29
SCS S-23	18 / 27	6.17	2.74	7.29	3.24
SCS S-21	17 / 26	6.29	2.69	7.43	3.18
SCS S-27	22 / 34	6.35	2.66	7.51	3.14
SCS S-43	16 / 25	6.42	2.63	7.59	3.11
SCS S-28	19 / 30	6.49	2.60	7.67	3.08
SCS S-29	15 / 24	6.58	2.57	7.78	3.04
SCS S-30	16 / 26	6.68	2.53	7.90	2.99
SCS S-41	17 / 28	6.77	2.50	8.00	2.95
SCS S-31	21 / 35	6.85	2.47	8.10	2.92
SCS S-33K	16 / 27	6.94	2.44	8.20	2.88
SCS S-33	17 / 29	7.01	2.41	8.29	2.85
SCS S-31K	14 / 24	7.05	2.40	8.33	2.84
SCS S-30K	15 / 26	7.12	2.37	8.42	2.80

WE ALSO CARRY THE FULL LINE OF WINTERS 10 SPLINE & 6 SPLINE QUICKCHANGE GEARS AT [www.southwestspeed.com](http://www.southwestspeed.com)

Place your order at (479) 646-6988, Fax to (479) 646-5939, or visit [www.southwestspeed.com](http://www.southwestspeed.com)



# 9" FORD REAR ENDS

★ALL SOUTHWEST SPEED 9" FORD RACING REAR END ASSEMBLIES COME COMPLETE WITH:

- \*SOLID AXLES (GUNDRILLED AVAILABLE FOR AN EXTRA COST), 28 OR 31 SPLINE
- \*SPINDLE NUTS & WASHERS
- \*ROTOR BOLT KITS
- \*5/8" COARSE THREAD STUDS
- \*DRIVE PLATES
- \*NECESSARY O-RINGS & BOLTS FOR THE HUB KITS
- \*AXLE SPACER BOLTS
- \*11 3/4" ROTORS, EITHER .810" OR 1.250" THICK
- \*HUBS, EITHER 5 x 4 3/4" OR 5 x 5"
- \*8 BOLT x 7" ROTOR PLATES
- \*WHEEL BEARINGS & SEALS
- \*SPINDLE SNOUT SEALS

★WHEN ORDERING, PLEASE SPECIFY IF YOU WANT 28 OR 31 SPLINE AXLES, AS WELL AS THE DESIRED LENGTH THAT YOU NEED

★LENGTH OF THE REAR END IS MEASURED FROM THE LEFT DRIVE PLATE FACE TO THE RIGHT DRIVE PLATE FACE; IN OTHER WORDS, FROM WHERE THE WHEEL BOLTS ON TO WHERE THE WHEEL BOLTS ON

★ALSO SPECIFY IF YOU WANT THE HOUSING CENTERED OR OFFSET

★"CENTERED" REFERS TO THE PINION BEING CENTERED IN THE REAR END; TUBES ON A "CENTERED" REAR END WON'T BE THE SAME LENGTH ON BOTH SIDES, BUT THE PINION WILL BE CENTERED IN THE REAR END

★60" CENTERED IS, BY FAR, THE MOST COMMON REAR END, BUT WE HAVE OR WE CAN BUILD ALMOST EVERY OTHER WIDTH AND OFFSET

## REAR END ASSEMBLIES WITH RECONDITIONED CENTER SECTIONS

- ★RECONDITIONED CENTER SECTION WITH NEW 3RD MEMBER STUD SET INSTALLED, ALL NECESSARY PLUGS, & NEW 3/16" THICK AXLE TUBES INSTALLED
- ★ALL ASSEMBLY PARTS (AXLES, HUBS, ROTORS, ETC.) ARE BRAND NEW
- ★AVAILABLE IN 60" CENTERED & 60" +2" LEFT -2" RIGHT

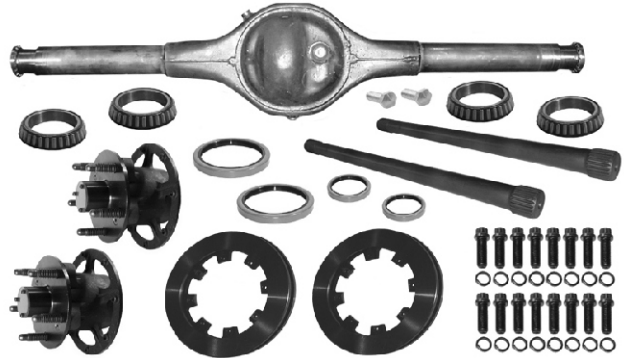

DESCRIPTION	PART #
COMPLETE REAR ASSY. W/5 x 4 3/4" HUBS	603-596
COMPLETE REAR ASSY. W/5 x 5" HUBS	603-597

## REAR END ASSEMBLIES WITH NEW CENTER SECTIONS

- ★ALL NEW COMPONENTS & MATERIALS
- ★3/16" TUBES ARE GROUND TO A TRUE 3" O.D. FOR EASY BIRD CAGE INSTALLATION; THIS ELIMINATES THE HOURS OF STRUGGLING TO GET THEM ON THE TUBE
- ★FEATURES VENT, FILL, & DRAIN PLUG BUNGS
- ★AVAILABLE IN ALMOST ANY WIDTH, CENTERED & OFFSET



DESCRIPTION	PART #
COMPLETE REAR ASSY. W/5 x 4 3/4" HUBS	603-598
COMPLETE REAR ASSY. W/5 x 5" HUBS	603-599

## REAR END ASSEMBLIES WITH NEW CENTERS & GM METRIC MOUNTS

- ★9" FORD REAR ENDS WITH UPPER & LOWER GM METRIC MOUNTS WELDED IN PLACE
- ★ALL NEW COMPONENTS & MATERIALS
- ★FEATURES VENT, FILL, & DRAIN PLUG BUNGS
- ★AVAILABLE IN 60" CENTERED

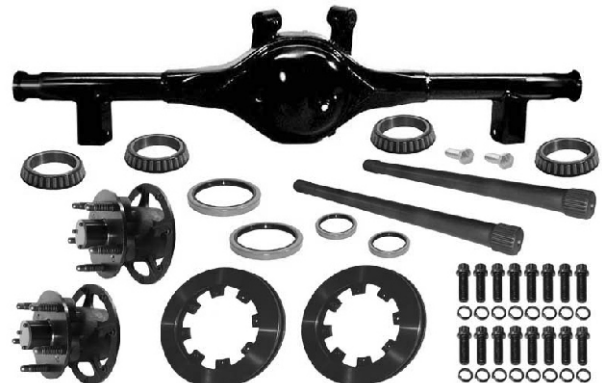

DESCRIPTION	PART #
COMPLETE REAR ASSY. W/5 x 4 3/4" HUBS	603-603
COMPLETE REAR ASSY. W/5 x 5" HUBS	603-604

Place your order at (479) 646-6988, Fax to (479) 646-5939, or visit [www.southwestspeed.com](http://www.southwestspeed.com)

# 9" FORD REAR END PARTS DIAGRAM

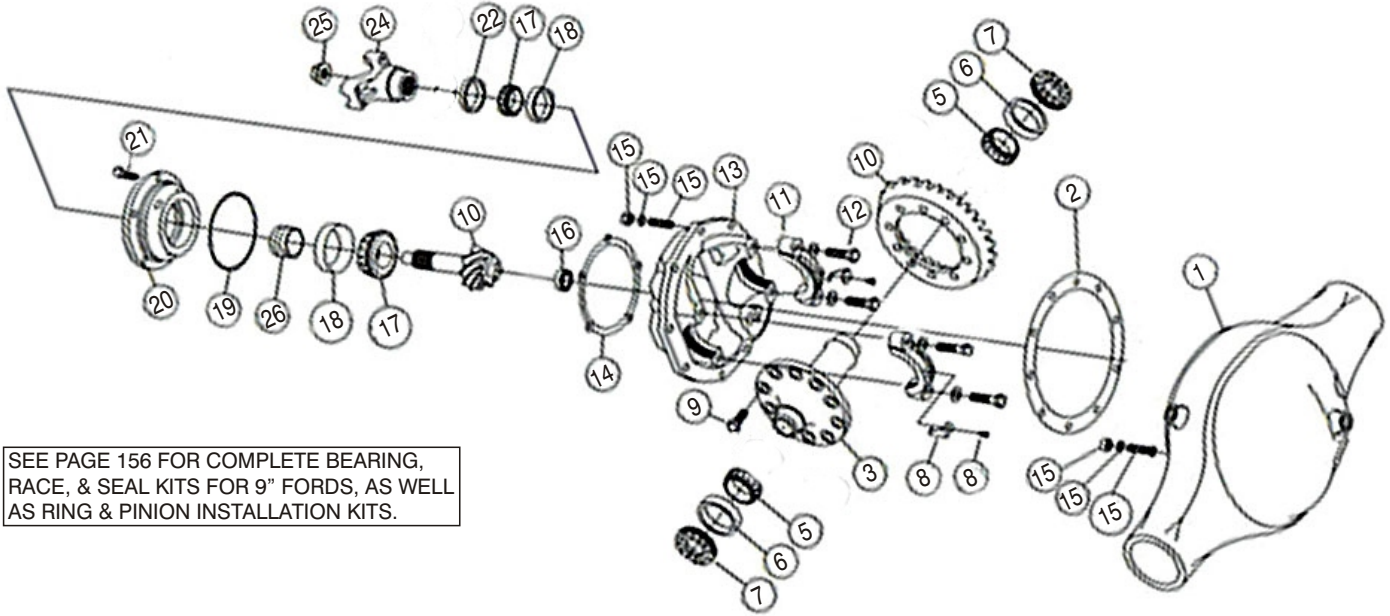

SEE PAGE 156 FOR COMPLETE BEARING, RACE, & SEAL KITS FOR 9" FORDS, AS WELL AS RING & PINION INSTALLATION KITS.

REF	DESCRIPTION	PART #
1	STEEL, 9" FORD CENTER HOUSING	603-680
2	GASKET, 9" FORD, PACK OF 5	603-306
3	28 SPLINE, STEEL SPOOL	603-049
3	31 SPLINE, STEEL SPOOL	603-050
3	28 SPLINE, ALUMINUM SPOOL	603-051
3	31 SPLINE, ALUMINUM SPOOL	603-052
3	28 SPLINE, LW STEEL SPOOL, SCALLOPED	603-055
3	31 SPLINE, LW STEEL SPOOL, SCALLOPED	603-056
5	CARRIER BEARING "A", 1.625"	603-313
5	CARRIER BEARING "B", 1.781"	603-314
6	CARRIER BEARING RACE, 2.891" O.D., "A"	603-315
6	CARRIER BEARING RACE, 2.891" O.D., "B"	603-316
7	ADJUSTING NUT, CARRIER BEARING	603-320
8	LOCKING TAB & BOLT, ADJUSTING NUT	603-324
9	RING GEAR BOLT SET, 7/16"-20 x 1" LONG	603-328
9	RING GEAR BOLT SET, 7/16"-20 x 7/8" LG	603-3287
10	RING & PINION GEAR SET (SEE PAGE 156)	-

REF	DESCRIPTION	PART #
11	CARRIER BEARING CAP, 2.891" I.D.	603-332
12	1/2" DIAMETER BEARING CAP BOLT	603-336
13	9" FORD CASE ONLY	603-500
14	SHIM KIT, PINION RETAINER	603-340
15	3RD MEMBER STUD & NUT KIT, 3/8"-24	603-334
15	3RD MEMBER NUT KIT, FLANGED, 3/8"-24	603-3345
16	BEARING, PINION NOSE	603-338
17	BEARING, PINION	603-342
18	BEARING RACE, PINION RETAINER, STOCK	603-350
19	PINION RETAINER, O-RING	603-361
20	PINION RETAINER, STOCK PINION	603-502
21	PINION RETAINER BOLT KIT, 3/8"	603-362
22	PINION YOKE SEAL	603-366
24	PINION YOKE, 28 SPLINE, STOCK, 3 7/32"	603-374
25	PINION SHAFT LOCK NUT, 3/4"-20	603-382
26	PINION SHIM KIT & SOLID SPACER	603-383
26	PINION CRUSH SLEEVE	603-384

## BARE HOUSINGS

- ★VENT, FILL, & DRAIN PLUG BUNGS
- ★AVAILABLE WITH TUBES FOR  
5 x 4 3/4" & 5 x 5"  
OR WIDE 5 HUBS



DESCRIPTION	PART #
9" FORD, RECONDITIONED CENTER, 5x5, 5x4.75	603-697
9" FORD, NEW CENTER, 5x5" & 5x4.75" TUBES	603-700
9" FORD, NEW CENTER, WIDE 5 TUBES	603-750
9" FORD W/ METRIC MOUNTS, NEW, 5x5, 5x4.75	603-704
9" FORD NEW BARE CENTER ONLY, NO TUBES	603-680

NOTE: 9" FORD HOUSINGS FOR WIDE 5 HUBS AND WITH METRIC MOUNTS ARE STOCKED ONLY IN 60" TRACK WIDTH. 9" FORD HOUSINGS FOR 5x5 & 5x4.75 HUBS ARE STOCKED IN MANY DIFFERENT OFFSETS AND NEED TO BE MEASURED ACCURATELY FOR PROPER REPLACEMENT.

## 9" FORD CASES

- ★NEW LIGHTWEIGHT CASTINGS
- ★REINFORCED
- ★ACCEPTS ALL FORD PARTS

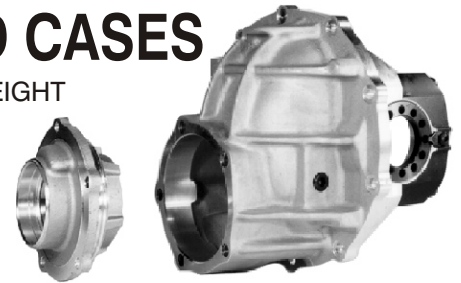

DESCRIPTION	PART #
9" FORD CASE ONLY	603-500
9" FORD BEARING RETAINER	603-502

## 9" FORD PINION YOKE

- ★ALL NEW CONSTRUCTION
- ★28 SPLINE
- ★FITS 1310 SERIES  
(1 1/16" O.D. CUPS x  
3 7/32" WIDE) U-JOINTS



PART #603-374

Place your order at (479) 646-6988, Fax to (479) 646-5939, or visit [www.southwestspeed.com](http://www.southwestspeed.com)

# COMPLETE 9" FORD 3RD MEMBERS

- ★3RD MEMBERS ARE SOLD COMPLETELY ASSEMBLED WITH NEW LIGHTWEIGHT 31 SPLINE FULL SPOOL, NEW PREMIUM RING & PINION, NEW BEARINGS, NEW PINION YOKE, NEW SOLID SHIM SET, 3RD MEMBER GASKET, & INSTRUCTIONS DETAILING PROPER BREAK-IN PROCEDURE
- ★PROFESSIONALLY SET UP WITH PROPER LASH
- ★THESE GEARS ARE ALSO AVAILABLE WITH TRAC-LOC UNITS, AS WELL AS IN 28 SPLINE; SEE [www.southwestspeed.com](http://www.southwestspeed.com) FOR THOSE ITEMS



RATIO	PART #	RATIO	PART #	RATIO	PART #
3.25	603-2214	5.00	603-2244	6.00	603-2271
3.33	603-2217	5.14	603-2247	6.20	603-2274
3.50	603-2220	5.29	603-2250	6.33	603-2277
3.70	603-2223	5.37	603-2253	6.50	603-2280
3.89	603-2226	5.43	603-2255	6.66	603-2283
4.11	603-2229	5.50	603-2259	6.83	603-2286
4.30	603-2232	5.57	603-2262	7.00	603-2289
4.56	603-2235	5.67	603-2264	7.16	603-2292
4.71	603-2238	5.83	603-2268	7.33	603-2295
4.86	603-2241				

# 9" FORD GEARS

- ★PREMIUM, 9310 HI-NICKEL ALLOY RACING RING & PINIONS
- ★PINIONS ARE PRECISION MATCHED TO RING GEARS



## STANDARD WEIGHT

RATIO	PART #	RATIO	PART #	RATIO	PART #
3.25	603-232	4.56	603-246	5.43	603-256
3.33	603-234	4.71	603-248	5.67	603-257
3.50	603-236	4.86	603-250	5.83	603-258
3.70	603-238	5.00	603-251	6.00	603-260
3.89	603-240	5.14	603-252	6.20	603-262
4.11	603-242	5.29	603-254	6.33	603-264
4.30	603-244	5.37	603-255	6.50	603-266

## LIGHTWEIGHT 9" FORD

RATIO	PART #	RATIO	PART #	RATIO	PART #
4.11	603-2421	5.37	603-2551	6.33	603-2641
4.30	603-2441	5.43	603-2559	6.50	603-2661
4.56	603-2461	5.50	603-2561	6.66	603-2681
4.71	603-2481	5.57	603-2562	6.83	603-2701
4.86	603-2501	5.67	603-2571	7.00	603-2721
5.00	603-2511	5.83	603-2581	7.16	603-2741
5.14	603-2521	6.00	603-2601	7.33	603-2761
5.29	603-2541	6.20	603-2621		

# 9" FORD BEARING, RACE, & SEAL KITS

- ★KITS INCLUDE ALL BEARINGS, RACES, & SEALS NEEDED TO BUILD A GEAR SET:  
2 CARRIER BEARINGS, 2 CARRIER BEARING RACES, 1 PINION NOSE BEARING, 2 STANDARD PINION BEARINGS, 2 STANDARD PINION BEARING RACES, & 1 PINION YOKE SEAL
- ★#603-450 FITS STOCK 28 SPLINE SPOOLS
- ★#603-451 FITS STOCK & AFTERMARKET 31 SPLINE SPOOLS, AS WELL AS MOST AFTERMARKET 28 SPLINE SPOOLS



DESCRIPTION	PART #
BEARING KIT, 1.625" ID, 2.891" OD CARRIER	603-450
BEARING KIT, 1.781" ID, 2.891" OD CARRIER	603-451

# 9" FORD RING & PINION INSTALLATION KITS

- ★INCLUDES ALL PARTS NECESSARY TO SETUP & INSTALL A 9" GEAR:  
3RD MEMBER GASKET, PINION RETAINER SHIM KIT, PINION RETAINER O-RING, PINION SHAFT LOCK NUT, 3 OZ. TUBE OF BLUE SILICON GASKET SEALER, AND EITHER A PINION SHIM KIT & SOLID SPACER OR A CRUSH SLEEVE



DESCRIPTION	PART #
INSTALL KIT WITH SOLID SPACER	603-429
INSTALL KIT WITH CRUSH SLEEVE	603-430
THIRD MEMBER GASKETS ONLY (5 PACK)	603-306

# CHEVY RING & PINIONS

- ★9310 HI-NICKEL ALLOY CONSTRUCTION
- ★PINIONS ARE PRECISION MATCHED TO RING GEARS

RING GEAR DIAMETER	RATIO	PART #
10 BOLT, 7.500" & 7.625"	3.42	603-790
10 BOLT, 7.500" & 7.625"	3.73	603-792
10 BOLT, 7.500" & 7.625"	4.10	603-794
10 BOLT, 7.500" & 7.625"	4.56	603-796
10 BOLT, 8.500"	3.42	603-802
10 BOLT, 8.500"	3.73	603-806
10 BOLT, 8.500"	4.11	603-808
10 BOLT, 8.500"	4.56	603-809
10 BOLT, 8.500"	4.88	603-810
10 BOLT, 8.500"	5.13	603-812
12 BOLT, 8.875"	3.73	603-846
12 BOLT, 8.875"	4.11	603-848
12 BOLT, 8.875"	4.56	603-850
12 BOLT, 8.875"	4.88	603-852

Place your order at (479) 646-6988, Fax to (479) 646-5939, or visit [www.southwestspeed.com](http://www.southwestspeed.com)



# GEAR STORAGE BUCKET

- ★ DURABLE PLASTIC
- ★ HOLDS GEAR LUBE
- ★ STORES & PROTECTS 3RD MEMBER



**PART #RCI 7044A**

# REAR END FILLER



- ★ SPUN ALUMINUM
- ★ -10 AN FITTING
- ★ 1/4 TURN, PLATED CAP
- ★ RECESSED MOUNTING FLANGE

**PART #600-050**

# DIAMOND TRACKS & DETROIT LOCKERS

- ★ UNDER DECELERATION, DIAMOND TRACKS & DETROIT LOCKERS BOTH ALLOW THE LEFT REAR TO FREE-SPIN, WHILE THE RIGHT REAR STAYS LOCKED IN & KEEPS PULLING; THEN UNDER ACCELERATION, THEY LOCK BOTH WHEELS BACK IN
- ★ A DIAMOND TRACK USES ADDITIONAL GEARS TO ACCOMPLISH THIS, WHILE A DETROIT LOCKER USES A PRECISION SPRING

## DIAMOND TRACKS

- ★ ALL LIGHTWEIGHT ALUMINUM



DESCRIPTION	PART #
9" FORD, 28 SPLINE, ALUMINUM, 1.781"	603-039
9" FORD, 31 SPLINE, ALUMINUM, 1.781"	603-040
QUICKCHANGE, 31 SPLINE, ALUMINUM	604-040
31 SPLINE 9" & Q.C. LOCK UP PLUG ONLY	604-035

## DETROIT LOCKERS

- ★ STEEL
- 9" FORD & ALUMINUM QUICKCHANGE



DESCRIPTION	PART #
9" FORD, 28 SPLINE, STEEL, 1.781"	603-036
9" FORD, 31 SPLINE, STEEL, 1.781"	603-038
9" FORD, 31 SPLINE, STEEL, 2.000"*	603-037
QUICKCHANGE 31 SPLINE, ALUMINUM	604-045
*#603-037 HAS LARGER, 2.000" O.D. BEARING JOURNAL DESIGNED TO FIT LARGER, DAYTONA-STYLE BEARINGS	

# REAR END SPOOLS MINI-SPOOLS

- ★ MINI-SPOOLS REPLACE SPUR GEARS TO LOCK REAR END
- ★ HIGH QUALITY, HEAT-TREATED, FORGED 8620 STEEL CONSTRUCTION
- ★ LIGHTWEIGHT DESIGN



DESCRIPTION	PART #
9" FORD, 28 SPLINE MINI-SPOOL	603-028
9" FORD, 31 SPLINE MINI-SPOOL	603-031
GM, 10 BOLT, 7.5", 26 SPLINE MINI-SPOOL	603-0001
GM, 10 BOLT, 8.2", 28 SPLINE MINI-SPOOL	603-0002
GM, 10 BOLT, 8.5", 28 SPLINE MINI-SPOOL	603-0003
GM, 12 BOLT, 8.875", 30 SPL. MINI-SPOOL	603-0004
DANA 44, 30 SPLINE MINI-SPOOL	603-0005
9" FORD HEAT-TREATED CROSS PIN	603-005

# FULL SPOOLS

- ★ HIGH QUALITY STEEL & ALUMINUM SPOOLS



DESCRIPTION	PART #
8" FORD, 31 SPLINE, ALUMINUM, 1.781"	603-048
9" FORD, 28 SPLINE, STEEL, 1.781"	603-049
9" FORD, 31 SPLINE, STEEL, 1.781"	603-050
9" FORD, 28 SPLINE, SCALLOPED STEEL	603-055
9" FORD, 31 SPLINE, SCALLOPED STEEL	603-056
9" FORD, 28 SPLINE, ALUMINUM, 1.781"	603-051
9" FORD, 31 SPLINE, ALUMINUM, 1.781"	603-052
GM, 10 BOLT, 8.5", 28 SPLINE, STEEL*	603-0412
GM, 10 BOLT, 8.5", 30 SPLINE, STEEL*	603-0413
GM, 12 BOLT, 8.875", 30 SPLINE, STEEL*	603-0411
QUICKCHANGE, 12 SPLINE, STEEL, LONG	604-050
QUICKCHANGE, 31 SPL., ALUMINUM**	604-051
QUICKCHANGE, 31 SPL., ALUMINUM**	604-053
*GM FULL SPOOLS WILL FIT ALL GM REAR ENDS, EXCEPT THOSE WITH DROP-OUT CENTER SECTIONS	
**#604-051 SPOOL FITS ALL QUICKCHANGE REAR ENDS, EXCEPT WINTERS; #604-053 FITS WINTERS QUICKCHANGE REAR ENDS ONLY	

# 9" FORD RING GEAR BOLTS

- ★ EXTRA-SMALL HEADS TO FIT ALL SPOOLS
- ★ SOLD IN PACKS OF 10



DESCRIPTION	PART #
7/16"-20 x 1" LONG, 12 POINT BOLT SET	603-328
7/16"-20 x 7/8" LONG, 12 POINT BOLT SET	603-3287

Place your order at (479) 646-6988, Fax to (479) 646-5939, or visit [www.southwestspeed.com](http://www.southwestspeed.com)

# DOUBLE SPLINED AXLES

★ONE IMPORTANT FACTOR TO DETERMINE WHEN BUYING AN AXLE IS WHETHER YOU NEED A 5x5 (GRAND NATIONAL) OR A WIDE 5 AXLE

★SOUTHWEST SPEED 5x5 AXLES STEP UP ON THE DRIVE PLATE END ABOUT 4" FROM THE SPLINES TO 1 3/8" IN DIAMETER, WHILE WIDE 5 AXLES HAVE ONE DIAMETER FOR THE COMPLETE LENGTH OF THE AXLE;

★HI-TORQUE, HEAT-TREATED RACING AXLES

★DOUBLE SPLINED:

28 OR 31 SPLINE INNER  
x 24 SPLINE OUTER

★GUN DRILLED AXLES ARE

POLISHED INTERNALLY &  
EXTERNALLY TO RELIEVE STRESS

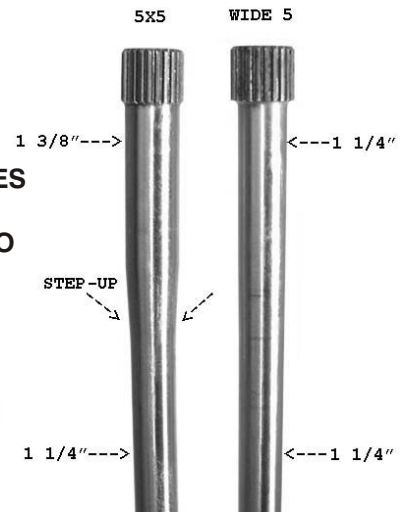

## 31 SPLINE

LENGTH	5x5		WIDE 5	
	SOLID	DRILLED	SOLID	DRILLED
23 1/2	605-4017	605-4517	605-5017	605-5593
24	605-4018	605-4518	605-5018	605-5594
24 1/2	605-4019	605-4519	605-5019	605-5595
25	605-402	605-452	605-502	605-5596
25 1/2	605-404	605-454	605-504	605-5597
26	605-406	605-456	605-506	605-5598
26 1/2	605-408	605-458	605-508	605-5599
27	605-410	605-460	605-510	605-560
27 1/2	605-412	605-462	605-512	605-562
28	605-414	605-464	605-514	605-564
28 1/2	605-416	605-466	605-516	605-566
29	605-418	605-468	605-518	605-568
29 1/2	605-420	605-470	605-520	605-570
30	605-422	605-472	605-522	605-572
30 1/2	605-424	605-474	605-524	605-574
31	605-426	605-476	605-526	605-576
31 1/2	605-428	605-478	605-528	605-578
32	605-430	605-480	605-530	605-580
32 1/2	605-432	605-482	605-532	605-582
33	605-434	605-484	605-534	605-584
33 1/2	605-436	605-486	605-536	605-586
34	605-438	605-488	605-538	605-588
34 1/2	605-440	605-490	605-540	605-590
35	605-442	605-492	605-542	605-592
35 1/2	605-444	605-494	605-544	605-594
36	605-446	605-496	605-546	605-596
36 1/2	605-448	605-498	605-548	605-598
37	605-4481	605-4981	605-550	605-600
37 1/2	605-4482	605-4982	605-552	605-602
38	605-4483	605-4983	605-554	605-604
38 1/2	605-4484	605-4984	605-556	605-606
39	605-4485	605-4985	605-558	605-608
39 1/2	N/A	N/A	605-5581	605-610
40	N/A	N/A	605-5582	605-612
40 1/2	N/A	N/A	605-5583	605-614
41	N/A	N/A	605-5584	605-616
41 1/2	N/A	N/A	605-5585	605-618

## GUN-DRILLED AXLE PLUG

★3/4"-16 GUN-DRILLED AXLE PLUG  
★LIGHTWEIGHT ALUMINUM

PART #605-990



## 28 SPLINE

LENGTH	5x5		WIDE 5	
	SOLID	DRILLED	SOLID	DRILLED
23 1/2	605-7017	605-7517	605-8017	605-8517
24	605-7018	605-7518	605-8018	605-8518
24 1/2	605-7019	605-7519	605-8019	605-8519
25	605-702	605-752	605-802	605-852
25 1/2	605-704	605-754	605-804	605-854
26	605-706	605-756	605-806	605-856
26 1/2	605-708	605-758	605-808	605-858
27	605-710	605-760	605-810	605-860
27 1/2	605-712	605-762	605-812	605-862
28	605-714	605-764	605-814	605-864
28 1/2	605-716	605-766	605-816	605-866
29	605-718	605-768	605-818	605-868
29 1/2	605-720	605-770	605-820	605-870
30	605-722	605-772	605-822	605-872
30 1/2	605-724	605-774	605-824	605-874
31	605-726	605-776	605-826	605-876
31 1/2	605-728	605-778	605-828	605-878
32	605-730	605-780	605-830	605-880
32 1/2	605-732	605-782	605-832	605-882
33	605-734	605-784	605-834	605-884
33 1/2	605-736	605-786	605-836	605-886
34	605-738	605-788	605-838	605-888
34 1/2	605-740	605-790	605-840	605-890
35	N/A	N/A	605-842	605-892
35 1/2	N/A	N/A	605-844	605-894
36	N/A	N/A	605-846	605-896
36 1/2	N/A	N/A	605-848	605-898
37	N/A	N/A	605-8481	605-8981
37 1/2	N/A	N/A	605-8482	605-8982
38	N/A	N/A	605-8483	605-8983
38 1/2	N/A	N/A	605-8484	605-8984
39	N/A	N/A	605-8485	605-8985
39 1/2	N/A	N/A	605-8486	605-8986

## AXLE SPACER BOLTS

★3/4" LONG, POINTED  
AXLE SPACER BOLTS  
★COARSE & FINE  
THREAD AVAILABLE



DESCRIPTION	PART #
3/8"-16 COARSE POINTED BOLT	605-992
3/8"-24 FINE POINTED BOLT	605-993

Place your order at (479) 646-6988, Fax to (479) 646-5939, or visit [www.southwestspeed.com](http://www.southwestspeed.com)

# REAR END TUBES

- ★REPLACEMENT REAR END TUBES
- ★3" O.D. SEAMLESS TUBING
- ★ALUMINUM & 3/16" WALL STEEL TUBES AVAILABLE
- ★5x5 SNOOTS USE TWO 2 1/2" I.D. BEARINGS
- ★WIDE 5 SNOOTS USE A 2" I.D. INNER BEARING & A 1 13/16" I.D. OUTER BEARING
- ★LENGTH IS MEASURED FROM THE END OF THE TUBE TO WHERE THE INNER HUB BEARING BOTTOMS OUT ON THE SNOOT

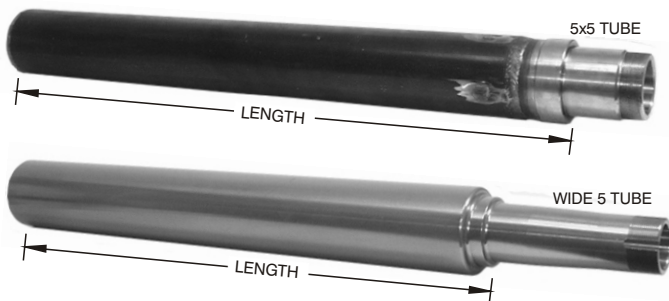

LENGTH	5x5 LEFT	5x5 RIGHT	WIDE 5 STEEL	WIDE 5 ALUM.
18	605-002	N/A	605-102	605-152
18 1/2	605-004	N/A	605-104	605-154
19	605-006	N/A	605-106	605-156
19 1/2	605-008	605-058	605-108	605-158
20	605-010	605-060	605-110	605-160
20 1/2	605-012	605-062	605-112	605-162
21	605-014	605-064	605-114	605-164
21 1/2	605-016	605-066	605-116	605-166
22	605-018	605-068	605-118	605-168
22 1/2	605-020	605-070	605-120	605-170
23	605-022	605-072	605-122	605-172
23 1/2	605-024	605-074	605-124	605-174
24	605-026	605-076	605-126	605-176
24 1/2	605-028	605-078	605-128	605-178
25	N/A	605-080	605-130	605-180
25 1/2	N/A	605-082	605-132	605-182
26	N/A	605-084	605-134	605-184
26 1/2	N/A	605-086	605-136	605-186
27	N/A	605-088	N/A	N/A
29 1/2	N/A	N/A	N/A	605-198

# TUBE & AXLE SEALS

- ★AVAILABLE FOR 4 DIFFERENT AXLE TUBE WALL THICKNESSES
- ★SEALS FIT SNUGLY IN 3" O.D. AXLE TUBES & SEAL ON AXLES
- ★O-RING EXTERNAL SEALS & DOUBLE LIP INTERNAL SEAL KEEP GEAR LUBE IN HOUSING



DESCRIPTION	PART #
2.750" O.D. SEAL FOR 1/8" WALL TUBES	603-070
2.625" O.D. SEAL FOR 3/16" WALL TUBES	603-072
2.562" O.D. SEAL FOR 7/32" WALL TUBES	603-073
2.500" O.D. SEAL FOR 1/4" WALL TUBES	603-074
REPLACEMENT INSERT SEAL ONLY	603-080
O-RING KIT ONLY FOR 1/8" & 3/16" TUBES	603-077
O-RING KIT ONLY FOR 7/32" TUBES	603-078
O-RING KIT ONLY FOR 1/4" TUBES	603-079

# SNOUT & AXLE SEALS

- ★PRESSES INTO 5x5 SNOOTS
- ★SEALS WIDE 5 OR 5x5 AXLES USING THE 5x5 SNOOTS



DESCRIPTION	PART #
SNOUT SEAL FOR WIDE 5 AXLES	601-099
SNOUT SEAL FOR 5x5 AXLES	601-100

# REAR END SNOOTS

- ★5x5 & WIDE 5 SNOOTS
- ★FIT 3" O.D. X 3/16" WALL AXLE TUBES
- ★DESIGNED TO PRESS FIT & WELD



DESCRIPTION	PART #
5x5, LEFT HAND THREAD	601-101
5x5, RIGHT HAND THREAD	601-103
WIDE 5, RIGHT HAND THREAD	603-101

# REAR END FILLER



- ★SPUN ALUMINUM
- ★-10 AN FITTING
- ★1/4 TURN, PLATED CAP
- ★RECESSED MOUNTING FLANGE

PART #600-050

# LUCAS HEAVY DUTY "PLUS" GEAR OIL

- ★WITH LUCAS GEAR OIL YOU CAN EXPECT LONGER OIL LIFE, LOWER OIL TEMPERATURES, LONGER COMPONENT LIFE, FEWER SEAL LEAKS, & LESS POWER LOSS



DESCRIPTION	PART #
85/140 PLUS GEAR OIL, 1 QUART	LOP 10042
80/90 PLUS GEAR OIL, 1 QUART	LOP 10043
85/140 PLUS GEAR OIL, 1 GALLON	LOP 10045
80/90 PLUS GEAR OIL, 1 GALLON	LOP 10046

# MAG 1 GEAR OIL

- ★EXCEEDS PERFORMANCE STANDARDS OF THE AUTOMOTIVE PERFORMANCE INDUSTRY
- ★AVAILABLE IN 80W90 & 85W140
- ★AVAILABLE IN QUARTS & GALLONS



DESCRIPTION	PART #
GEAR OIL, 80W90, 1 QUART	940-055
GEAR OIL, 85W140, 1 QUART	940-057
GEAR OIL, 80W90, 1 GALLON	940-060

NOTE: FOR A CONSTANT STREAM OF NEW PRODUCTS & UP-TO-THE-SECOND PRICING, VISIT [WWW.SOUTHWESTSPEED.COM](http://WWW.SOUTHWESTSPEED.COM)

Place your order at (479) 646-6988, Fax to (479) 646-5939, or visit [www.southwestspeed.com](http://www.southwestspeed.com)



# WIDE 5 HUBS

- ★LIGHTWEIGHT ALUMINUM WIDE 5 HUBS
- ★BEARING RACES & 5/8" COARSE STUDS INCLUDED
- ★STUDS ARE GUN-DRILLED ON #270-6513D & #270-6735D TO ELIMINATE CRUCIAL ROTATING WEIGHT
- ★8 BOLT X 7.00" ROTOR BOLT CIRCLES
- ★#270-1956C CAN BE USED ON THE FRONT OR THE REAR, WHILE #270-6513D IS FOR THE REAR & #270-6735D IS FOR THE FRONT
- ★USE WITH ROTORS WITH AN 8 BOLT X 7.00" BOLT CIRCLE; SEE PAGES 63 & 64

#WIL 270-1956C



#WIL 270-6513D



#WIL 270-6735D



DRIVE FLANGE PATTERN	FRONT OR REAR	BOLT CIRCLE	LBS.	PART #
8 BOLT	F or R	8x7.00"	6.99	WIL 270-1956C
5 BOLT	REAR	8x7.00"	6.71	WIL 270-6513D
N/A*	FRONT	8x7.00"	6.57	WIL 270-6735D

\*#270-6735D COMES WITH PLASTIC DUST COVER

# WIDE 5 BEARINGS & SEALS



OUTER BEARING 201-482    INNER BEARING 201-484    WHEEL SEAL 201-480    OUTER RACE 201-486    INNER RACE 201-488

# WIDE 5 SPINDLE NUTS

- ★SELF LOCKING NUTS; 1 13/16"-16 THREAD
- ★KITS INCLUDE SPINDLE NUT, THRUST & LOCK WASHER, & 2 ALLEN BOLTS
- ★SLOTTED WASHERS ALLOW FOR UNLIMITED ADJUSTMENT
- ★FITS ALL WIDE 5 SPINDLES



DESCRIPTION	PART #
STEEL KIT, COMPLETE	201-500
ALUMINUM KIT, COMPLETE	201-501
STEEL NUT ONLY	201-504
ALUMINUM NUT ONLY	201-505
THRUST WASHER ONLY	201-507
LOCK WASHER ONLY	201-508
ALLEN BOLT FOR STEEL NUT ONLY	201-509
ALLEN BOLT FOR ALUMINUM NUT ONLY	201-510

# WIDE 5 HUBS DUST COVER

- ★LIGHTWEIGHT ALUMINUM
- ★SCALLOPED, 2 BOLT DESIGN FITS WIDE 5 HUBS WITH AN 8 BOLT DRIVE FLANGE PATTERN



PART #201-516

# 8 BOLT DRIVE FLANGES



- ★7075-T6 ALUMINUM
- ★POPULAR 24 SPLINE
- ★INCLUDES O-RING HUB CAP
- ★FITS ANY 8 BOLT, WIDE 5 HUB

DESCRIPTION	PART #
8 BOLT, WIDE 5 DRIVE FLANGE	601-512
8 BOLT, WIDE 5 DRIVE FLANGE	WIL 270-2290

# 5 BOLT DRIVE FLANGES

- ★FITS ANY 5 BOLT, WIDE 5 HUB
- ★POPULAR 24 SPLINE
- ★INCLUDES O-RING HUB CAP
- ★7075-T6 ALUMINUM



DESCRIPTION	PART #
5 BOLT, WIDE 5 DRIVE FLANGE	601-513
5 BOLT, WIDE 5 DRIVE FLANGE	WIL 270-6733

# DRIVE FLANGE BOLT KITS



- ★HIGH QUALITY PLATED BOLTS
- ★FITS ANY WIDE 5 HUB
- ★5 BOLT OR 8 BOLT KITS

DESCRIPTION	PART #
8 PCS, DRIVE FLANGE BOLT KIT	601-516
5 PCS, DRIVE FLANGE BOLT KIT	601-517

# SPINDLE NUT WRENCHES

- ★ANODIZED ALUMINUM CONSTRUCTION
- ★1/2" SQUARE DRIVE



DESCRIPTION	PART #
SPINDLE NUT WRENCH, WIDE 5	790-210
SPINDLE NUT WRENCH, 5 x 5	790-211

# WHEEL BEARING GREASE

- ★HIGH TEMP PROTECTION
- ★WATER RESISTANT
- ★EXTENDS BEARING LIFE

PART #940-063



Place your order at (479) 646-6988, Fax to (479) 646-5939, or visit [www.southwestspeed.com](http://www.southwestspeed.com)

## 5 x 5" REAR HUBS

- ★1 PIECE HUB AND ROTOR PLATE CASTING
- ★5/8" COARSE THREADED STUDS
- ★8 BOLT x 7.00" ROTOR CIRCLE
- ★STEEL DRIVE PLATE
- ★USES #203-104 ROTOR BOLT KIT



DESCRIPTION	PART #
5x5" RACING REAR HUB KIT	601-188
STEEL DRIVE PLATE W/ CAP & O-RING	601-172
DRIVE PLATE TO HUB BOLT	601-173
HUB TO DRIVE PLATE O-RING	601-174
HUB CAP BOLT KIT, 3 PIECES	601-175
HUB CAP O-RING ONLY	601-176
HUB CAP WITH BOLTS & O-RING	601-178
5x5 HUB ONLY WITH STUDS & RACES	601-180
SEAL SNAP RING	601-181
INNER & OUTER RACE (SOLD EACH)	601-200
INNER & OUTER WHEEL BEARING (EACH)	601-202
WHEEL SEAL	601-250

## 5 x 4 3/4" REAR HUBS

- ★1 PIECE HUB AND ROTOR PLATE CASTING
- ★8 BOLT x 7.00" ROTOR CIRCLE
- ★5/8" COARSE THREADED STUDS
- ★STEEL DRIVE PLATE
- ★USES #203-104 ROTOR BOLT KIT



DESCRIPTION	PART #
5x4 3/4" RACING REAR HUB KIT	601-187
STEEL DRIVE PLATE WITH CAP & O-RING	601-171
DRIVE PLATE TO HUB BOLT	601-173
HUB TO DRIVE PLATE O-RING	601-174
HUB CAP BOLT KIT, 3 PIECES	601-175
HUB CAP O-RING ONLY	601-176
HUB CAP WITH BOLTS & O-RING	601-178
5x4 3/4" HUB ONLY WITH STUDS & RACES	601-179
SEAL SNAP RING	601-181
INNER & OUTER RACE (SOLD EACH)	601-200
INNER & OUTER WHEEL BEARING (EACH)	601-202
WHEEL SEAL	601-250

## COMPLETE REAR HUB BEARING & NUTS KITS

- ★FIT 5x5" & 5x4 3/4" REAR HUBS
- ★KITS INCLUDE 2 WHEEL BEARINGS, 1 WHEEL SEAL, 1 SNOUT SEAL, 1 SPINDLE LOCK WASHER, & 1 SPINDLE NUT (LEFT OR RIGHT)



DESCRIPTION	PART #
REAR HUB BEARING KIT, LEFT-HAND	601-278
REAR HUB BEARING KIT, RIGHT-HAND	601-280

NOTE: SEE PAGE 63 & 64 FOR THE BRAKE ROTORS

## BEARINGS & SEALS FOR 5x5 & 5x4 3/4 REAR HUBS



INNER / OUTER BEARING  
601-202



WHEEL SEAL  
601-250



INNER / OUTER RACE  
601-200

## SPINDLE NUTS TANGED LOCKING

- ★TANGED LOCKING NUT
- ★2 3/8"-18 THREAD



DESCRIPTION	PART #
STEEL, LEFT HAND NUT	601-260
ALUMINUM, LEFT HAND NUT	601-261
STEEL, RIGHT HAND NUT	601-262
ALUMINUM, RIGHT HAND NUT	601-263
TANGED WASHER	601-265

## SELF LOCKING

- ★SELF LOCKING NUT KITS; 2 3/8"-18 THREAD
- ★KITS INCLUDE SPINDLE NUT, THRUST & LOCK WASHER, & 2 ALLEN BOLTS
- ★SLOTTED WASHERS ALLOW FOR UNLIMITED ADJUSTMENT
- ★FITS ALL 5x5" & 5x4 3/4" REAR HUBS



DESCRIPTION	PART #
5x5 SPINDLE NUT KIT, STEEL, LH	601-270
5x5 SPINDLE NUT KIT, ALUMINUM, LH	601-271
5x5 SPINDLE NUT KIT, STEEL, RH	601-272
5x5 SPINDLE NUT KIT, ALUMINUM, RH	601-273

## 5 x 5" BILLET HUB PARTS

- ★THESE PARTS WILL FIT THE OLDER SOUTHWEST SPEED GOLD BILLET STEEL HUBS (SHOWN), AS WELL AS STOCK CAR PRODUCTS HUBS

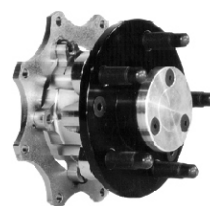

COMPLETE OLDER HUB



#601-212



#601-214

DESCRIPTION	PART #
COMPLETE ALUMINUM DRIVE PLATE*	601-212
DRIVE PLATE TO HUB O-RING	601-216
DRIVE PLATE CAP O-RING	601-218
DRIVE PLATE TO HUB BOLT	601-223
DRIVE PLATE CAP BOLT KIT, 3 PIECES	601-225
WHEEL LOCATOR**	601-214
*7075-T6 ALUM. DRIVE PLATE IS 24 SPLINE & INCLUDES CAP & O-RING	
**ADD-ON WHEEL LOCATOR BOLTS DIRECTLY IN PLACE OF THE DRIVE PLATE CAP & REGISTERS THE WHEEL QUICKLY FOR FAST TIRE CHANGES	

Place your order at (479) 646-6988, Fax to (479) 646-5939, or visit [www.southwestspeed.com](http://www.southwestspeed.com)

# WHEEL STUDS SCREW-IN STUDS

- ★1/2"-20 THREADS x 3" LONG
- ★FITS ALL AFTER MARKET AXLES WITH 1/2"-20 THREADS
- ★SOLD IN PACKS OF 5

**PART  
#205-548**



# PRESS-IN STUDS

- ★HIGH QUALITY, HARDENED STEEL
- ★2 5/8" & 3 5/8" LONG
- ★.690" KNURL O.D.
- ★QUICK START FEATURE  
DESIGNED FOR FASTER TIRE CHANGES
- ★SOLD IN PACKS OF 5 OR BOXES OF 50



DESCRIPTION	PART #
5/8"-11 COARSE THREAD, 2 5/8" LONG	205-554
5/8"-11 COARSE THREAD, 3 5/8" LONG	205-556
5/8"-18 FINE, 2 5/8" LONG	205-552
5/8"-18 FINE, 2 5/8" LONG, SHORT KNURL	205-551

# MOROSO PRESS-IN STUDS

- ★MANUFACTURED FROM HIGH GRADE SAE 8740 STEEL
- ★QUICK START FEATURE
- ★SOLD & PRICED IN PACKS OF 5

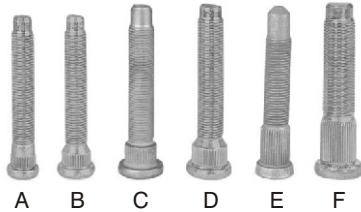

DESCRIPTION	PART #
7/16"-20 x 2 7/8", .480" KNURL (A)	MOR 46150
7/16"-20 x 2 7/8", .560" KNURL (B)	MOR 46160
1/2"-20 x 3", .615" KNURL (C)	MOR 46180
1/2"-20 x 3", .685" KNURL (D)	MOR 46190
1/2"-20 x 3", .563" KNURL (E)	MOR 46220
5/8"-18 x 3", .672" KNURL (F)	MOR 46240

# WHEEL STUD DRILL BIT

- ★43/64" DRILL BIT WITH 1/2" SHANK
- ★USED TO DRILL HUBS & AXLES TO PROPER DIAMETER FOR .690" KNURL WHEEL STUDS



**PART  
#807-682**

# THREAD CHASERS

- ★HEAT TREATED
- ★1" SOCKET SIZE
- ★SELF CLEANING
- ★ALLOWS STRAIGHTENING & CLEANING OF THREADS



DESCRIPTION	PART #
THREAD CHASER, 5/8"-18 THREADS	790-202
THREAD CHASER, 5/8"-11 THREADS	790-204

# LUG NUTS

- ★SINGLE SIDED & DOUBLE SIDED AVAILABLE
- ★1" SOCKET SIZE
- ★EXTRA STRENGTH, PLATED STEEL

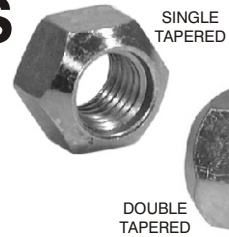

DESCRIPTION	SINGLE TAPER	DOUBLE TAPER
12 MM -1.5 THREAD	205-499	205-509
7/16"-20 FINE THREAD	205-500	205-510
1/2"-20 FINE THREAD	205-501	205-511
5/8"-18 FINE THREAD	205-502	205-512
5/8"-11 COARSE THREAD	205-504	205-514

# SPEEDY LUG WRENCH

- ★EXTRA DEEP 1" SOCKET
- ★PVC FREE-SPINNING MIDDLE HANDLE
- ★TAPERED OUTER HANDLES WITH TOUGH, RUBBER GRIPS



**PART  
#790-010**

# WHEEL ADAPTERS

5 x 5"

- ★ENABLES YOU TO PUT A 5x5" WHEEL ON A 5 x 4 1/2" OR A 5 x 4 3/4" HUB
- ★1" THICK ALUMINUM CONSTRUCTION
- ★COMES WITH 5/8"-11 COARSE STUDS INSTALLED
- ★ALSO INCLUDES THE FIVE 1/2"-20 THREADED ALLEN BOLTS TO REPLACE YOUR CURRENT STUDS & ATTACH THE ADAPTER TO THE HUB



**PART  
#601-730**

WIDE 5

- ★THESE ADAPTERS ENABLE YOU TO PUT A WIDE 5 WHEEL ON 5 x 4 1/2", 5 x 4 3/4", OR 5 x 5" HUBS
- ★PLATED STEEL CONSTRUCTION
- ★COMES WITH 5/8"-11 COARSE STUDS INSTALLED
- ★NOT TO BE USED WITH CARBON FIBER OR PLASTIC WHEELS



DESCRIPTION	PART #
5 x 4 1/2" TO WIDE 5 ADAPTER	601-710
5 x 4 3/4" TO WIDE 5 ADAPTER	601-711
5 x 5" TO WIDE 5 ADAPTER	601-712

Place your order at (479) 646-6988, Fax to (479) 646-5939, or visit [www.southwestspeed.com](http://www.southwestspeed.com)



# WHEEL SPACERS

## MULTI-PATTERN ALUMINUM



- ★LIGHTWEIGHT MULTI-PATTERN
- ★FITS 5 x 4 1/2", 5 x 4 3/4", & 5 x 5" BOLT PATTERNS
- ★CAN BE STACKED TOGETHER TO GET THE PERFECT THICKNESS

DESCRIPTION	PART #
1/8" ALUMINUM WHEEL SPACER	601-752
1/4" ALUMINUM WHEEL SPACER	601-753
3/8" ALUMINUM WHEEL SPACER	601-754
1/2" ALUMINUM WHEEL SPACER	601-755
3/4" ALUMINUM WHEEL SPACER	601-757
1" ALUMINUM WHEEL SPACER	601-759

NOTE: 2" SPACER FOR 5x5" ONLY AVAILABLE; SEE BELOW

## 5 x 5" ALUMINUM, 2"

- ★2" THICK 6061-T6 BILLET ALUMINUM
- ★2 5/8" LONG, 5/8"-11 COARSE STUDS INSTALLED
- ★FITS 5 x 5" HUBS ONLY



**PART #601-790**

## 5 x 5" STEEL

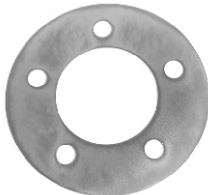

- ★PRECISION STAMPED STEEL
- ★SPACERS PROTECT HUBS
- ★CAN BE STACKED TOGETHER TO GET THE PERFECT THICKNESS
- ★FIT 5 x 5" HUBS ONLY

DESCRIPTION	PART #
1/16" STEEL WHEEL SPACER	601-741
1/8" STEEL WHEEL SPACER	601-742
1/4" STEEL WHEEL SPACER	601-744

## WIDE 5 SPACER, 2"

- ★2" SPACER WILL FIT ALL HUBS WITH WIDE 5 BOLT PATTERN
- ★ALMAG ALLOY CONSTRUCTION
- ★CUSTOM, ZIG-ZAG DESIGN ELIMINATES CRUCIAL ROTATING WEIGHT
- ★5/8" COARSE STUDS INSTALLED



**PART # WIL 270-2189C**

## SCREW-ON SPACERS, 1/2"



- ★1/2" THICK ALUMINUM SPACERS
- ★5/8"-11 COARSE THREADS
- ★WORK ON ANY HUB WITH THE 5/8"-11 STUDS
- ★SOLD & PRICED IN PACKS OF 5

**PART #601-795**

# UNIVERSAL MUD PLUGS

## FRONT OF WHEEL - CLEAR

- ★FITS IN THE FRONT OF ANY NON-BEADLOCK, 15" WHEEL W/ NO WELDING REQUIRED
- ★FEATURES AN EASILY REMOVABLE CLEAR LEXAN COVER WITH 3 CAM LOCKS



**PART #200-980**

## FRONT OF WHEEL - CLEAR FOR BEADLOCKS

- ★FITS 15" WHEEL WITH BEADLOCKS
- ★FEATURES 16 BOLT PATTERN, WHICH IS COMMON ON MANY BRANDS OF WHEELS, BUT SIMPLE DRILLING WILL ALLOW THEM TO FIT ANY BRAND
- ★CLEAR, HIGH IMPACT CARBONATE COVER IS REMOVABLE WITH 3 DZUS FASTENERS



**PART #W BL15UMG**

## BACK OF WHEEL - ALUMINUM

- ★LIGHTWEIGHT ALUMINUM PLUGS FIT IN THE BACK OF THE WHEEL TO PREVENT MUD FROM PACKING IN THE WHEEL
- ★FOR USE WITH 15" WHEEL
- ★MULTI-PATTERN DESIGN ALLOWS PLUGS TO FIT 5 x 4 1/2", 5 x 4 3/4", & 5 x 5" BOLT PATTERNS
- ★AVAILABLE TO FIT WHEELS WITH 2", 3", & 4" BACKSPACING



BEFORE INSTALLATION, PLACE ON HUB BY HAND TO CHECK ALL BRAKE ROTOR & CALIPER CLEARANCES AND PLACE IN WHEEL TO CHECK WHEEL BACKSPACING DEPTH

DESCRIPTION	PART #
MUD PLUG FOR 2" BACKSPACE WHEEL	200-962
MUD PLUG FOR 3" BACKSPACE WHEEL	200-963
MUD PLUG FOR 4" BACKSPACE WHEEL	200-964

## INSIDE WHEEL - FOAM

- ★HIGH DENSITY FOAM CONFORMS INTO ALMOST ANY 15" WHEEL TO PREVENT MUD FROM PACKING INSIDE OF WHEEL



DESCRIPTION	PART #
FOAM MUD PLUG, BLACK	200-982
FOAM MUD PLUG, BLUE	200-983
FOAM MUD PLUG, RED	200-984
FOAM MUD PLUG, YELLOW	200-985
FOAM MUD PLUG, ORANGE	200-986
FOAM MUD PLUG, PURPLE	200-988

Place your order at (479) 646-6988, Fax to (479) 646-5939, or visit [www.southwestspeed.com](http://www.southwestspeed.com)

# 15" x 10" ALLIED STEEL WHEELS

- ★STANDARD & LIGHTWEIGHT 15" x 10" STEEL WHEELS
- ★POWDER-COATED BLACK & SILVER AND PLATED CHROME WHEELS AVAILABLE
- ★ALLIED CHROME IS AN ACTUAL PLATED CHROME, NOT A POWDER-COATED CHROME LIKE OTHER BRANDS



NOTE: BACKSPACING IS MEASURED BY LAYING THE WHEEL FLAT ON THE FLOOR WITH THE FACE UP & MEASURING FROM THE FLOOR TO THE MOUNTING FACE IN THE CENTER OF THE WHEEL; I.E.: FLOOR TO BACK OF WHEEL CENTER

## CHROME 15x10 - 30LBS

BOLT PATTERN	BACK SPACING	PART #
5 x 4 1/2	2"	W 7050012-20
5 x 4 1/2	3"	W 7050012-30
5 x 4 1/2	4"	W 7050012-40
5 x 4 1/2	5"	W 7050012-50
5 x 4 3/4	2"	W 7050034-20
5 x 4 3/4	3"	W 7050034-30
5 x 4 3/4	4"	W 7050034-40
5 x 4 3/4	5"	W 7050034-50
5 x 5	2"	W 7050050-20
5 x 5	3"	W 7050050-30
5 x 5	4"	W 7050050-40
5 x 5	5"	W 7050050-50

## LIGHTWEIGHT CHROME 15x10 - 23LBS

BOLT PATTERN	BACK SPACING	PART #
5 x 4 1/2	2"	W 7250012-20
5 x 4 1/2	3"	W 7250012-30
5 x 4 1/2	4"	W 7250012-40
5 x 4 1/2	5"	W 7250012-50
5 x 4 3/4	2"	W 7250034-20
5 x 4 3/4	3"	W 7250034-30
5 x 4 3/4	4"	W 7250034-40
5 x 4 3/4	5"	W 7250034-50
5 x 5	2"	W 7250050-20
5 x 5	3"	W 7250050-30
5 x 5	4"	W 7250050-40
5 x 5	5"	W 7250050-50

## BLACK 15x10 - 30LBS

BOLT PATTERN	BACK SPACING	PART #
5 x 4 1/2	2"	W 7150012-20
5 x 4 1/2	3"	W 7150012-30
5 x 4 1/2	4"	W 7150012-40
5 x 4 1/2	5"	W 7150012-50
5 x 4 3/4	2"	W 7150034-20
5 x 4 3/4	3"	W 7150034-30
5 x 4 3/4	4"	W 7150034-40
5 x 4 3/4	5"	W 7150034-50
5 x 5	2"	W 7150050-20
5 x 5	3"	W 7150050-30
5 x 5	4"	W 7150050-40
5 x 5	5"	W 7150050-50

## LIGHTWEIGHT BLACK 15x10 - 21LBS

BOLT PATTERN	BACK SPACING	PART #
5 x 4 1/2	2"	W 7350012-20
5 x 4 1/2	3"	W 7350012-30
5 x 4 1/2	4"	W 7350012-40
5 x 4 1/2	5"	W 7350012-50
5 x 4 3/4	2"	W 7350034-20
5 x 4 3/4	3"	W 7350034-30
5 x 4 3/4	4"	W 7350034-40
5 x 4 3/4	5"	W 7350034-50
5 x 5	2"	W 7350050-20
5 x 5	3"	W 7350050-30
5 x 5	4"	W 7350050-40
5 x 5	5"	W 7350050-50

## SILVER 15x10 - 30LBS

BOLT PATTERN	BACK SPACING	PART #
5 x 4 1/2	2"	W 7850012-20
5 x 4 1/2	3"	W 7850012-30
5 x 4 1/2	4"	W 7850012-40
5 x 4 1/2	5"	W 7850012-50
5 x 4 3/4	2"	W 7850034-20
5 x 4 3/4	3"	W 7850034-30
5 x 4 3/4	4"	W 7850034-40
5 x 4 3/4	5"	W 7850034-50
5 x 5	2"	W 7850050-20
5 x 5	3"	W 7850050-30
5 x 5	4"	W 7850050-40
5 x 5	5"	W 7850050-50

## LIGHTWEIGHT SILVER 15x10 - 21LBS

BOLT PATTERN	BACK SPACING	PART #
5 x 4 1/2	2"	W 7950012-20
5 x 4 1/2	3"	W 7950012-30
5 x 4 1/2	4"	W 7950012-40
5 x 4 1/2	5"	W 7950012-50
5 x 4 3/4	2"	W 7950034-20
5 x 4 3/4	3"	W 7950034-30
5 x 4 3/4	4"	W 7950034-40
5 x 4 3/4	5"	W 7950034-50
5 x 5	2"	W 7950050-20
5 x 5	3"	W 7950050-30
5 x 5	4"	W 7950050-40
5 x 5	5"	W 7950050-50

Place your order at (479) 646-6988, Fax to (479) 646-5939, or visit [www.southwestspeed.com](http://www.southwestspeed.com)

# 15" x 10" ALLIED STEEL WHEELS WITH BEADLOCKS

- ★STANDARD & LIGHTWEIGHT 15" x 10" STEEL WHEELS
- ★POWDER-COATED BLACK & SILVER AND PLATED CHROME WHEELS AVAILABLE
- ★ALLIED CHROME IS AN ACTUAL PLATED CHROME, NOT A POWDER-COATED CHROME LIKE OTHER BRANDS

NOTE: BACKSPACING IS MEASURED BY LAYING THE WHEEL FLAT ON THE FLOOR WITH THE FACE UP & MEASURING FROM THE FLOOR TO THE MOUNTING FACE IN THE CENTER OF THE WHEEL; I.E.: FLOOR TO BACK OF WHEEL CENTER



## CHROME 15x10 BEADLOCK - 35LBS

BOLT PATTERN	BACK SPACING	PART #
5 x 4 1/2	2"	W BL7050012-20
5 x 4 1/2	3"	W BL7050012-30
5 x 4 1/2	4"	W BL7050012-40
5 x 4 1/2	5"	W BL7050012-50
5 x 4 3/4	2"	W BL7050034-20
5 x 4 3/4	3"	W BL7050034-30
5 x 4 3/4	4"	W BL7050034-40
5 x 4 3/4	5"	W BL7050034-50
5 x 5	2"	W BL7050050-20
5 x 5	3"	W BL7050050-30
5 x 5	4"	W BL7050050-40
5 x 5	5"	W BL7050050-50

## LIGHTWEIGHT CHROME 15x10 BL - 28LBS

BOLT PATTERN	BACK SPACING	PART #
5 x 4 1/2	2"	W BL7250012-20
5 x 4 1/2	3"	W BL7250012-30
5 x 4 1/2	4"	W BL7250012-40
5 x 4 1/2	5"	W BL7250012-50
5 x 4 3/4	2"	W BL7250034-20
5 x 4 3/4	3"	W BL7250034-30
5 x 4 3/4	4"	W BL7250034-40
5 x 4 3/4	5"	W BL7250034-50
5 x 5	2"	W BL7250050-20
5 x 5	3"	W BL7250050-30
5 x 5	4"	W BL7250050-40
5 x 5	5"	W BL7250050-50

## BLACK 15x10 BEADLOCK - 35LBS

BOLT PATTERN	BACK SPACING	PART #
5 x 4 1/2	2"	W BL7150012-20
5 x 4 1/2	3"	W BL7150012-30
5 x 4 1/2	4"	W BL7150012-40
5 x 4 1/2	5"	W BL7150012-50
5 x 4 3/4	2"	W BL7150034-20
5 x 4 3/4	3"	W BL7150034-30
5 x 4 3/4	4"	W BL7150034-40
5 x 4 3/4	5"	W BL7150034-50
5 x 5	2"	W BL7150050-20
5 x 5	3"	W BL7150050-30
5 x 5	4"	W BL7150050-40
5 x 5	5"	W BL7150050-50

## LIGHTWEIGHT BLACK 15x10 BL - 28LBS

BOLT PATTERN	BACK SPACING	PART #
5 x 4 1/2	2"	W BL7350012-20
5 x 4 1/2	3"	W BL7350012-30
5 x 4 1/2	4"	W BL7350012-40
5 x 4 1/2	5"	W BL7350012-50
5 x 4 3/4	2"	W BL7350034-20
5 x 4 3/4	3"	W BL7350034-30
5 x 4 3/4	4"	W BL7350034-40
5 x 4 3/4	5"	W BL7350034-50
5 x 5	2"	W BL7350050-20
5 x 5	3"	W BL7350050-30
5 x 5	4"	W BL7350050-40
5 x 5	5"	W BL7350050-50

## SILVER 15x10 BEADLOCK - 35LBS

BOLT PATTERN	BACK SPACING	PART #
5 x 4 1/2	2"	W BL7850012-20
5 x 4 1/2	3"	W BL7850012-30
5 x 4 1/2	4"	W BL7850012-40
5 x 4 1/2	5"	W BL7850012-50
5 x 4 3/4	2"	W BL7850034-20
5 x 4 3/4	3"	W BL7850034-30
5 x 4 3/4	4"	W BL7850034-40
5 x 4 3/4	5"	W BL7850034-50
5 x 5	2"	W BL7850050-20
5 x 5	3"	W BL7850050-30
5 x 5	4"	W BL7850050-40
5 x 5	5"	W BL7850050-50

## LIGHTWEIGHT SILVER 15x10 BL - 28LBS

BOLT PATTERN	BACK SPACING	PART #
5 x 4 1/2	2"	W BL7950012-20
5 x 4 1/2	3"	W BL7950012-30
5 x 4 1/2	4"	W BL7950012-40
5 x 4 1/2	5"	W BL7950012-50
5 x 4 3/4	2"	W BL7950034-20
5 x 4 3/4	3"	W BL7950034-30
5 x 4 3/4	4"	W BL7950034-40
5 x 4 3/4	5"	W BL7950034-50
5 x 5	2"	W BL7950050-20
5 x 5	3"	W BL7950050-30
5 x 5	4"	W BL7950050-40
5 x 5	5"	W BL7950050-50

Place your order at (479) 646-6988, Fax to (479) 646-5939, or visit [www.southwestspeed.com](http://www.southwestspeed.com)



# 15" x 8" ALLIED STEEL WHEELS

- ★STANDARD & LIGHTWEIGHT 15" x 8" STEEL WHEELS
- ★POWDER-COATED BLACK & SILVER AND PLATED CHROME WHEELS
- ★ALLIED CHROME IS AN ACTUAL PLATED CHROME, NOT A POWDER-COATED CHROME LIKE OTHER BRANDS



NOTE: BACKSPACING IS MEASURED BY LAYING THE WHEEL FLAT ON THE FLOOR WITH THE FACE UP & MEASURING FROM THE FLOOR TO THE MOUNTING FACE IN THE CENTER OF THE WHEEL;  
I.E.: FLOOR TO BACK OF WHEEL CENTER

## CHROME 15x8 - 23LBS

BOLT PATTERN	BACK SPACING	PART #
5 x 4 1/2	2"	W 7058012-20S
5 x 4 1/2	3"	W 7058012-30S
5 x 4 1/2	4"	W 7058012-40S
5 x 4 1/2	5"	W 7058012-50S
5 x 4 3/4	2"	W 7058034-20S
5 x 4 3/4	3"	W 7058034-30S
5 x 4 3/4	4"	W 7058034-40S
5 x 4 3/4	5"	W 7058034-50S
5 x 5	1"	W 7058050-10S
5 x 5	2"	W 7058050-20S
5 x 5	3"	W 7058050-30S
5 x 5	4"	W 7058050-40S
5 x 5	4 1/2"	W 7058050-45S
5 x 5	5"	W 7058050-50S

## LIGHTWEIGHT CHROME 15x8 - 19LBS

BOLT PATTERN	BACK SPACING	PART #
5 x 4 1/2	2"	W 7258012-20S
5 x 4 1/2	3"	W 7258012-30S
5 x 4 1/2	4"	W 7258012-40S
5 x 4 1/2	5"	W 7258012-50S
5 x 4 3/4	1"	W 7258034-10S
5 x 4 3/4	2"	W 7258034-20S
5 x 4 3/4	3"	W 7258034-30S
5 x 4 3/4	4"	W 7258034-40S
5 x 4 3/4	5"	W 7258034-50S
5 x 5	1"	W 7258050-10S
5 x 5	2"	W 7258050-20S
5 x 5	3"	W 7258050-30S
5 x 5	4"	W 7258050-40S
5 x 5	5"	W 7258050-50S

## BLACK 15x8 - 23LBS

BOLT PATTERN	BACK SPACING	PART #
5 x 4 1/2	2"	W 7158012-20S
5 x 4 1/2	3"	W 7158012-30S
5 x 4 1/2	4"	W 7158012-40S
5 x 4 1/2	5"	W 7158012-50S
5 x 4 3/4	1"	W 7158034-10S
5 x 4 3/4	2"	W 7158034-20S
5 x 4 3/4	3"	W 7158034-30S
5 x 4 3/4	4"	W 7158034-40S
5 x 4 3/4	5"	W 7158034-50S
5 x 5	2"	W 7158050-20S
5 x 5	3"	W 7158050-30S
5 x 5	4"	W 7158050-40S
5 x 5	4 1/2"	W 7158050-45S
5 x 5	5"	W 7158050-50S

## LIGHTWEIGHT BLACK 15x8 - 19 LBS

BOLT PATTERN	BACK SPACING	PART #
5 x 4 1/2	2"	W 7358012-20S
5 x 4 1/2	3"	W 7358012-30S
5 x 4 1/2	4"	W 7358012-40S
5 x 4 1/2	5"	W 7358012-50S
5 x 4 3/4	2"	W 7358034-20S
5 x 4 3/4	3"	W 7358034-30S
5 x 4 3/4	4"	W 7358034-40S
5 x 4 3/4	5"	W 7358034-50S
5 x 5	1"	W 7358050-10S
5 x 5	2"	W 7358050-20S
5 x 5	3"	W 7358050-30S
5 x 5	4"	W 7358050-40S
5 x 5	5"	W 7358050-50S

## SILVER 15x8 - 23LBS

BOLT PATTERN	BACK SPACING	PART #
5 x 4 1/2	2"	W 7858012-20S
5 x 4 1/2	3"	W 7858012-30S
5 x 4 1/2	4"	W 7858012-40S
5 x 4 1/2	5"	W 7858012-50S
5 x 4 3/4	2"	W 7858034-20S
5 x 4 3/4	3"	W 7858034-30S
5 x 4 3/4	4"	W 7858034-40S
5 x 4 3/4	5"	W 7858034-50S
5 x 5	2"	W 7858050-20S
5 x 5	3"	W 7858050-30S
5 x 5	4"	W 7858050-40S
5 x 5	5"	W 7858050-50S

## LIGHTWEIGHT SILVER 15x8 - 19LBS

BOLT PATTERN	BACK SPACING	PART #
5 x 4 1/2	2"	W 7958012-20S
5 x 4 1/2	3"	W 7958012-30S
5 x 4 1/2	4"	W 7958012-40S
5 x 4 1/2	5"	W 7958012-50S
5 x 4 3/4	2"	W 7958034-20S
5 x 4 3/4	3"	W 7958034-30S
5 x 4 3/4	4"	W 7958034-40S
5 x 4 3/4	5"	W 7958034-50S
5 x 5	1"	W 7958050-10S
5 x 5	2"	W 7958050-20S
5 x 5	3"	W 7958050-30S
5 x 5	4"	W 7958050-40S
5 x 5	5"	W 7958050-50S

Place your order at (479) 646-6988, Fax to (479) 646-5939, or visit [www.southwestspeed.com](http://www.southwestspeed.com)

# 15" x 8" ALLIED STEEL WHEELS WITH BEADLOCKS

- ★STANDARD & LIGHTWEIGHT 15" x 8" STEEL WHEELS
- ★POWDER-COATED BLACK & SILVER AND PLATED CHROME WHEELS AVAILABLE
- ★ALLIED CHROME IS AN ACTUAL PLATED CHROME, NOT A POWDER-COATED CHROME LIKE OTHER BRANDS

NOTE: BACKSPACING IS MEASURED BY LAYING THE WHEEL FLAT ON THE FLOOR WITH THE FACE UP & MEASURING FROM THE FLOOR TO THE MOUNTING FACE IN THE CENTER OF THE WHEEL; I.E.: FLOOR TO BACK OF WHEEL CENTER



## CHROME 15x8 BEADLOCK - 31LBS

BOLT PATTERN	BACK SPACING	PART #
5 x 4 1/2	2"	W BL7058012-20S
5 x 4 1/2	3"	W BL7058012-30S
5 x 4 1/2	4"	W BL7058012-40S
5 x 4 1/2	5"	W BL7058012-50S
5 x 4 3/4	2"	W BL7058034-20S
5 x 4 3/4	3"	W BL7058034-30S
5 x 4 3/4	4"	W BL7058034-40S
5 x 4 3/4	5"	W BL7058034-50S
5 x 5	2"	W BL7058050-20S
5 x 5	3"	W BL7058050-30S
5 x 5	4"	W BL7058050-40S
5 x 5	5"	W BL7058050-50S

## LIGHTWEIGHT CHROME 15x8 BL - 26LBS

BOLT PATTERN	BACK SPACING	PART #
5 x 4 1/2	2"	W BL7258012-20S
5 x 4 1/2	3"	W BL7258012-30S
5 x 4 1/2	4"	W BL7258012-40S
5 x 4 1/2	5"	W BL7258012-50S
5 x 4 3/4	2"	W BL7258034-20S
5 x 4 3/4	3"	W BL7258034-30S
5 x 4 3/4	4"	W BL7258034-40S
5 x 4 3/4	5"	W BL7258034-50S
5 x 5	2"	W BL7258050-20S
5 x 5	3"	W BL7258050-30S
5 x 5	4"	W BL7258050-40S
5 x 5	5"	W BL7258050-50S

## BLACK 15x8 BEADLOCK - 31LBS

BOLT PATTERN	BACK SPACING	PART #
5 x 4 1/2	2"	W BL7158012-20S
5 x 4 1/2	3"	W BL7158012-30S
5 x 4 1/2	4"	W BL7158012-40S
5 x 4 1/2	5"	W BL7158012-50S
5 x 4 3/4	2"	W BL7158034-20S
5 x 4 3/4	3"	W BL7158034-30S
5 x 4 3/4	4"	W BL7158034-40S
5 x 4 3/4	5"	W BL7158034-50S
5 x 5	2"	W BL7158050-20S
5 x 5	3"	W BL7158050-30S
5 x 5	4"	W BL7158050-40S
5 x 5	5"	W BL7158050-50S

## LIGHTWEIGHT BLACK 15x8 BL - 26LBS

BOLT PATTERN	BACK SPACING	PART #
5 x 4 1/2	2"	W BL7358012-20S
5 x 4 1/2	3"	W BL7358012-30S
5 x 4 1/2	4"	W BL7358012-40S
5 x 4 1/2	5"	W BL7358012-50S
5 x 4 3/4	2"	W BL7358034-20S
5 x 4 3/4	3"	W BL7358034-30S
5 x 4 3/4	4"	W BL7358034-40S
5 x 4 3/4	5"	W BL7358034-50S
5 x 5	1"	W BL7358050-10S
5 x 5	2"	W BL7358050-20S
5 x 5	3"	W BL7358050-30S
5 x 5	4"	W BL7358050-40S
5 x 5	5"	W BL7358050-50S

## SILVER 15x8 BEADLOCK - 31LBS

BOLT PATTERN	BACK SPACING	PART #
5 x 4 1/2	2"	W BL7858012-20S
5 x 4 1/2	3"	W BL7858012-30S
5 x 4 1/2	4"	W BL7858012-40S
5 x 4 1/2	5"	W BL7858012-50S
5 x 4 3/4	2"	W BL7858034-20S
5 x 4 3/4	3"	W BL7858034-30S
5 x 4 3/4	4"	W BL7858034-40S
5 x 4 3/4	5"	W BL7858034-50S
5 x 5	2"	W BL7858050-20S
5 x 5	3"	W BL7858050-30S
5 x 5	4"	W BL7858050-40S
5 x 5	5"	W BL7858050-50S

## LIGHTWEIGHT SILVER 15x8 BL - 26LBS

BOLT PATTERN	BACK SPACING	PART #
5 x 4 1/2	2"	W BL7958012-20S
5 x 4 1/2	3"	W BL7958012-30S
5 x 4 1/2	4"	W BL7958012-40S
5 x 4 1/2	5"	W BL7958012-50S
5 x 4 3/4	2"	W BL7958034-20S
5 x 4 3/4	3"	W BL7958034-30S
5 x 4 3/4	4"	W BL7958034-40S
5 x 4 3/4	5"	W BL7958034-50S
5 x 5	1"	W BL7958050-10S
5 x 5	2"	W BL7958050-20S
5 x 5	3"	W BL7958050-30S
5 x 5	4"	W BL7958050-40S
5 x 5	5"	W BL7958050-50S

Place your order at (479) 646-6988, Fax to (479) 646-5939, or visit [www.southwestspeed.com](http://www.southwestspeed.com)

# 15" x 7" ALLIED STEEL WHEELS

- ★STANDARD & LIGHTWEIGHT 15" x 7" STEEL WHEELS
- ★POWDER-COATED BLACK & SILVER AND PLATED CHROME WHEELS AVAILABLE
- ★ALLIED CHROME IS AN ACTUAL PLATED CHROME, NOT A POWDER-COATED CHROME LIKE OTHER BRANDS



NOTE: BACKSPACING IS MEASURED BY LAYING THE WHEEL FLAT ON THE FLOOR WITH THE FACE UP & MEASURING FROM THE FLOOR TO THE MOUNTING FACE IN THE CENTER OF THE WHEEL; I.E.: FLOOR TO BACK OF WHEEL CENTER

## CHROME 15x7 - 22LBS

BOLT PATTERN	BACK SPACING	PART #
5 x 4 1/2	2"	W 7057012-20
5 x 4 1/2	3"	W 7057012-30
5 x 4 1/2	4"	W 7057012-40
5 x 4 1/2	5"	W 7057012-50
5 x 4 3/4	2"	W 7057034-20
5 x 4 3/4	3"	W 7057034-30
5 x 4 3/4	4"	W 7057034-40
5 x 4 3/4	5"	W 7057034-50
5 x 5	2"	W 7057050-20
5 x 5	3"	W 7057050-30
5 x 5	3 3/4"	W 7057050-37
5 x 5	4"	W 7057050-40
5 x 5	5"	W 7057050-50

## LIGHTWEIGHT SILVER 15x7 - 18LBS

BOLT PATTERN	BACK SPACING	PART #
5 x 4 1/2	2"	W 7957012-20
5 x 4 1/2	3"	W 7957012-30
5 x 4 1/2	4"	W 7957012-40
5 x 4 1/2	5"	W 7957012-50
5 x 4 3/4	2"	W 7957034-20
5 x 4 3/4	3"	W 7957034-30
5 x 4 3/4	4"	W 7957034-40
5 x 4 3/4	5"	W 7957034-50
5 x 5	2"	W 7957050-20
5 x 5	3"	W 7957050-30
5 x 5	4"	W 7957050-40
5 x 5	5"	W 7957050-50

## BLACK 15x7 - 22LBS

BOLT PATTERN	BACK SPACING	PART #
5 x 4 1/2	2"	W 7157012-20
5 x 4 1/2	3"	W 7157012-30
5 x 4 1/2	4"	W 7157012-40
5 x 4 1/2	5"	W 7157012-50
5 x 4 3/4	2"	W 7157034-20
5 x 4 3/4	3"	W 7157034-30
5 x 4 3/4	3 3/4"	W 7157034-37
5 x 4 3/4	4"	W 7157034-40
5 x 4 3/4	5"	W 7157034-50
5 x 5	2"	W 7157050-20
5 x 5	3"	W 7157050-30
5 x 5	4"	W 7157050-40
5 x 5	5"	W 7157050-50

## LIGHTWEIGHT BLACK 15x7 - 18LBS

BOLT PATTERN	BACK SPACING	PART #
5 x 4 1/2	2"	W 7357012-20
5 x 4 1/2	3"	W 7357012-30
5 x 4 1/2	4"	W 7357012-40
5 x 4 1/2	5"	W 7357012-50
5 x 4 3/4	2"	W 7357034-20
5 x 4 3/4	3"	W 7357034-30
5 x 4 3/4	4"	W 7357034-40
5 x 4 3/4	5"	W 7357034-50
5 x 5	2"	W 7357050-20
5 x 5	3"	W 7357050-30
5 x 5	4"	W 7357050-40
5 x 5	5"	W 7357050-50

# 13" x 8" MINI-STOCK ALLIED STEEL WHEELS

- ★LIGHTWEIGHT, POWDER-COATED BLACK MINI-STOCK WHEELS
- ★4 x 4 1/2" BOLT PATTERN

NOTE: BACKSPACING IS MEASURED BY LAYING THE WHEEL FLAT ON THE FLOOR WITH THE FACE UP & MEASURING FROM THE FLOOR TO THE MOUNTING FACE IN THE CENTER OF THE WHEEL; I.E.: FLOOR TO BACK OF WHEEL CENTER



## LIGHTWEIGHT BLACK 13x8 - 13LBS

BOLT PATTERN	BACK SPACING	PART #
4 x 4 1/2	2"	W 7538044-20
4 x 4 1/2	3"	W 7538044-30
4 x 4 1/2	4"	W 7538044-40
4 x 4 1/2	5"	W 7538044-50

Place your order at (479) 646-6988, Fax to (479) 646-5939, or visit [www.southwestspeed.com](http://www.southwestspeed.com)



# ALLIED WHEELS WITH DAYTONA CENTER SECTIONS

★WE ALSO HAVE ALMOST EVERY ALLIED WHEEL IN STOCK WITH THE DAYTONA CENTER SECTION, WHICH HAS THE 10 SMALL "D" SHAPED HOLES, AS OPPOSED TO THE 7 HOLES IN THE STANDARD CENTER SECTION

★BESIDES THE CENTER SECTION, EVERYTHING ELSE ON THE STANDARD ALLIED & DAYTONA ALLIED IS THE SAME INCLUDING PRICE & WEIGHT

★TO GET THE DAYTONA PART #, JUST TAKE OUT THE "7" & INSERT A "5", i.e.:

\*W 7250050-20 = W 5250050-20

\*W BL7958034-20S = W BL5958034-20S



## BEADLOCK RINGS ONLY

★RINGS WILL FIT ALLIED 15" WHEELS ONLY

★AVAILABLE IN PLATED CHROME AND POWDER-COATED BLACK & SILVER



DESCRIPTION	PART #
BEADLOCK OUTER RING, CHROME	W BL15OR
BEADLOCK OUTER RING, BLACK	W BL15ORB
BEADLOCK OUTER RING, SILVER	W BL15ORS

## WHEEL STRAIGHTENING TOOL



PART #790-014

★WORKS GREAT ON ANY WHEEL  
 ★1/2" THICK STEEL CONSTRUCTION  
 ★APPROXIMATELY 17" LONG

## TIRE BEAD BREAKER

★USED ON ALL 15" WHEELS  
 ★WIDE FOOT PUSHES BEAD OFF WITH EASE  
 ★FEATURES COMFORTABLE RUBBER GRIP HANDLES



PART # 790-016

## RUBBER VALVE STEMS

★VALVE STEMS FOR 1/2" OR 5/8" HOLES

★HIGH TEMPERATURE RUBBER

★#944-028 & #944-030 ARE PRICED EACH & SOLD IN BOXES OF 50

★#944-038 & #944-040 ARE PRICED & SOLD IN PACKS OF 4



DESCRIPTION	PART #
STEMS FOR 1/2" HOLE , MINIMUM OF 50	944-028
STEMS FOR 1/2" HOLE , PACK OF 4	944-038
STEMS FOR 5/8" HOLE , MINIMUM OF 50	944-030
STEMS FOR 5/8" HOLE , PACK OF 4	944-040

## ALUMINUM VALVE STEMS

★LIGHTWEIGHT ALUMINUM  
 ★LOW PROFILE  
 ★FIT IN 5/8" HOLES  
 ★PRICED & SOLD IN PACKS OF 4



PART #944-032

## VALVE STEM TOOL

★REMOVES AND REPLACES THE CORE FROM THE VALVE STEM  
 ★COMES WITH 6 EXTRA CORES, WHICH CAN CONVENIENTLY BE STORED IN THE HANDLE



PART #944-020

NOTE: FOR A CONSTANT STREAM OF NEW PRODUCTS & UP-TO-THE-SECOND PRICING, VISIT [WWW.SOUTHWESTSPEED.COM](http://WWW.SOUTHWESTSPEED.COM)

Place your order at (479) 646-6988, Fax to (479) 646-5939, or visit [www.southwestspeed.com](http://www.southwestspeed.com)

# 8" WIDE SOUTHWEST SPEED RACING TIRE

- ★ SOUTHWEST SPEED IS ALWAYS LOOKING TO KEEP THE COST OF RACING DOWN
- ★ WITH LOWER COST, BETTER WEAR, & COMPETITIVE SPEED, THE \$69.99 SOUTHWEST SPEED TIRE IS ENGINEERED & DESIGNED WITH THAT SPECIFIC GOAL IN MIND
- ★ 26.0" x 8.0" x 15", 60 COMPOUND
- ★ COMPETITIVE WITH OTHER BRANDS OF 8" WIDE TIRES WITH SUBSTANTIALLY LESS WEAR & COST
- ★ **IN SOME CASES, THE SOUTHWEST SPEED TIRE IS LASTING 4-5 TIMES AS LONG AS OTHER BRANDS**
- ★ GREAT FOR USE IN ANY CLASS THAT RUNS AN 8" WIDE TIRE: MODIFIEDS, ECONOMY MODIFIEDS, LIMITED LATE MODELS, MINI-STOCKS, HOBBY STOCKS, FACTORY STOCKS, LEGENDS, ETC.
- ★ WHY RUN A \$85-100 TIRE THAT WILL WEAR OUT IN 1 NIGHT, WHEN YOU CAN RUN A \$69.99 TIRE THAT WILL LAST 4 TO 5 TIMES THAT LONG?

**\$69.99**

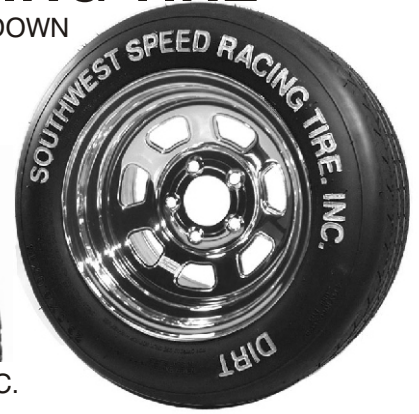

## TIRE GROOVER

- ★ 250 WATT GROOVER
- ★ FEATURES A NON-SLIP PISTOL GRIP & CHANGEABLE HEADS & BLADES
- ★ EACH GROOVER COMES W/ #4 HEAD & 12 PACK OF #4 (.215" WIDE) BLADES



PART #790-250

- ★ EACH WIDTH OF BLADE REQUIRES A SPECIFIC HEAD TO MATCH; BLADES ARE SOLD IN PACKS OF 12

BLADES SOLD IN PACKS OF 12		
SIZE	HEAD #	BLADE #
#1: .053"	790-251	790-261
#2: .090"	790-252	790-262
#3: .150"	790-253	790-263
#4: .215"	790-254	790-264
#5: .290"	790-255	790-265
#6: .375"	790-256	790-266
#8: .500"	790-257	790-267
#10: .625"	790-258	790-268
#12: .750"	790-259	790-269

## RAZOR TIRE SIPERS

- ★ GREAT FOR CUTTING RACING TIRES TO ALLOW THE TIRE TO HEAT UP FASTER
- ★ USED TO QUICKLY & PRECISELY SIPE TIRES FOR BETTER TRACTION
- ★ AVAILABLE WITH EITHER 6 OR 14 BLADES
- ★ VAN ALSTINE ELECTRIC TIRE SIPER ALSO AVAILABLE, WHICH HOLDS UP TO 13 BLADES



PART #790-2754



PART #VAM S-100

DESCRIPTION	PART #
6 BLADE TIRE SIPER	790-275
14 BLADE TIRE SIPER	790-2754
VAN ALSTINE ELECTRIC TIRE SIPER	VAM S-100
VAN ALSTINE BLADES, 24 PACK	VAM S-100 BLADE

YOU CAN FIND SEVERAL VARIATIONS OF TIRE SOFTENER ON PAGE 253

## VAN ALSTINE G-1000 GROOVER

- ★ UNLIKE OTHER GROOVERS, THIS DELUXE GROOVER IS INSTANTLY HOT; YOU DON'T HAVE TO WAIT FOR IT TO HEAT UP TO BEGIN GROOVING
- ★ PLUG THE G-1000 IN & IT INSTANTLY HEATS TO THE SETTING ON THE DIAL, WHICH HAS ADJUSTABLE HEAT SETTINGS 1-4
- ★ DESIGNED TO BE FAST, SMOOTH, & EASY
- ★ GLIDES OVER THE TIRE SURFACE & GIVES A PRECISE, CONSISTENT CUTTING DEPTH
- ★ CUTS WITH LESS HEAT THAN MOST GROOVERS, WHICH PREVENTS HEAT DEGRADATION TO RACE TIRE SURFACE
- ★ G-1000 IS DESIGNED TO MEET THE EXACTING DEMANDS OF MODERN TIRE GROOVING
- ★ COMES WITH AN 8 BLADE STARTER ASSORTMENT



PART #VAM G-1000

## VAN ALSTINE V-100 GROOVER

- ★ THIS IS VAN ALSTINE'S SMALLER, LIGHTER ALTERNATIVE TO THE G-1000
- ★ THIS ELIMINATES THE CONTROL BOX, AS EVERYTHING IS BUILT RIGHT IN TO THE HANDLE, YET IT ONLY WEIGHS ABOUT 3 LBS.
- ★ IT IS STILL INSTANTLY HOT & HAS 6 ADJUSTABLE SETTINGS
- ★ THE ONLY DOWNSIDE IS THAT IT WILL ONLY GROOVE UP TO 1/2" WIDE GROOVES, WHILE THE G-1000 WILL GROOVE UP TO 1"
- ★ COMES WITH A 4 BLADE STARTER ASSORTMENT



PART #VAM V-100

SIZE	BLADES SOLD IN PACKS OF 12 FOR VAN ALSTINE:	
	G-1000	V-100
#1: 1/32"	VAM GRD01	VAM VR01
#2: 1/16"	VAM GRD02	VAM VR02
#3: 3/32"	VAM GFD03	VAM VF03
#4: 1/8"	VAM GFD04	VAM VF04
#5: 5/32"	VAM GFD05	VAM VF05
#6: 3/16"	VAM GFD06	VAM VF06
#8: 1/4"	VAM GFD08	VAM VF08
#10: 5/16"	VAM GFD10	VAM VF10
#12: 3/8"	VAM GFD12	VAM VF12
#14: 7/16"	VAM GFD14	VAM VF14
#16: 1/2"	VAM GFD16	VAM VF16
#18: 9/16"	VAM GFD18	-
#20: 5/8"	VAM GFD20	-
#24: 3/4"	VAM GFD24	-
#28: 7/8"	VAM GFD28	-
#32: 1"	VAM GFD32	-

Place your order at (479) 646-6988, Fax to (479) 646-5939, or visit [www.southwestspeed.com](http://www.southwestspeed.com)

# TIRE GRINDING DISCS

- ★ CARBIDE & NAIL HEAD GRINDING DISCS ENABLE YOU TO REJUVENATE OLD TIRES WITH EASE
- ★ MANY CARBIDE DISCS ON THE MARKET FLAKE APART AFTER USE; YOU WON'T HAVE THAT PROBLEM WITH THE SOUTHWEST SPEED DISCS
- ★ 5/8" - 11 NUT WELDED IN THE MIDDLE OF THE CARBIDE DISCS
- ★ 7/8" ARBOR HOLE IN THE MIDDLE OF THE NAIL HEAD DISCS

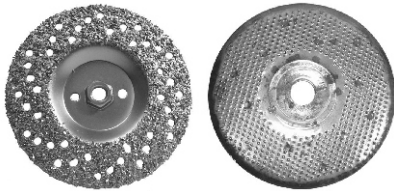

DESCRIPTION	PART #
CARBIDE GRINDING DISC, 4" OD	790-017
CARBIDE GRINDING DISC, 7" OD	790-018
NAIL HEAD GRINDING DISC, 7" OD	790-0188

# TIRE MARKER

- ★ USED TO RECORD LOCATIONS ON THE TIRE & CIRCUMFERENCES
- ★ CAN ALSO BE USED TO LETTER THE SIDE OF TIRES



PART #790-007

# TAPE MEASURES

- ★ #790-003 IS SPECIFICALLY DESIGNED FOR MEASURING TIRES
- ★ IT WILL NOT WRINKLE



DESCRIPTION	PART #
TIRE TAPE MEASURE, 1/4" x 120" LONG	790-003
SHOP TAPE MEASURE, 3/4" x 25' LONG	790-004

# TIRE STAGGER GAUGE

- ★ MEASURES TIRE CIRCUMFERENCE
- ★ WHITE, EASY-TO-READ SCALE MEASURES FROM 65" TO 115"
- ★ POWDER-COATED BLACK, LIGHTWEIGHT ALUMINUM CONSTRUCTION

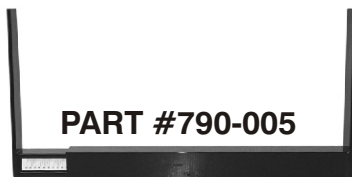

PART #790-005

# TIRE STAGGER ROLLER

- ★ ROLLER DESIGN ALLOWS YOU TO CHECK STAGGER EASILY & ACCURATELY
- ★ ALSO ENABLES YOU TO CLEAN, GROOVE, GRIND, & SIPE TIRES MUCH EASIER
- ★ INCLUDES LONGACRE 10' TAPE MEASURE



PART #LON 50850

# DELUXE PIT KITS

- ★ KITS INCLUDE: \*SPEEDY LUG WRENCH, \*STAGGER GAUGE, \*TIRE MARKER, \*AIR PRESSURE GAUGE (0-60 PSI), & \*PIT MAT (BLACK, BLUE, OR RED)



DESCRIPTION	PART #
DELUXE PIT KIT WITH BLACK PIT MAT	790-0112
DELUXE PIT KIT WITH BLUE PIT MAT	790-0113
DELUXE PIT KIT WITH RED PIT MAT	790-0114

# TIRE PRESSURE GAUGES

- ★ EASY TO READ 2" DIAL
- ★ THUMB GRIP AIR BLEED
- ★ NON-CRIMPING HOSE
- ★ PROTECTIVE RUBBER BOOT



DESCRIPTION	PART #
0-15 PSI TIRE PRESSURE GAUGE	790-080
0-30 PSI TIRE PRESSURE GAUGE	790-082
0-60 PSI TIRE PRESSURE GAUGE	790-084

# DIGITAL AIR GAUGE

- ★ READS 0 - 100 PSI IN .2 LB. INCREMENTS
- ★ AIR PRESSURE RELEASE BUTTON
- ★ ULTRA-FLEXIBLE 14" LINE WITH BALL CHUCK



PART #LON 50347

# ALUMINUM AIR TANKS

- ★ LIGHTWEIGHT ALUMINUM, 7 GALLON AIR TANKS WITH FILLER GAUGES
- ★ SAVES TIME BY NOT DRAGGING THE AIR HOSE AROUND THE CAR
- ★ 7 GALLONS SHOULD TOP OFF 4 TIRES
- ★ CONNECT YOUR AIR LINE, PRESS THE LEVER, & FILL YOUR TIRES TWICE AS FAST
- ★ FEATURES A BLEED BUTTON FOR EXCESS PRESSURE & A LARGE ACCURATE GLOW-IN-THE-DARK GAUGE FACE



DESCRIPTION	PART #
TANK & FILLER GAUGE, 0-30 PSI	LON 50462
TANK & FILLER GAUGE, 0-60 PSI	LON 50460

Place your order at (479) 646-6988, Fax to (479) 646-5939, or visit [www.southwestspeed.com](http://www.southwestspeed.com)



# TIRE DUROMETER & TREAD DEPTH GAUGE

- ★DUROMETER WITH HARD CASE:
  - \*TESTS TIRE HARDNESS, WHICH CHANGES AS TIRES GET OLDER & EVEN VARIES BETWEEN TIRES
  - \*DUROMETERS CAN KEEP TRACK OF EXACTLY WHERE YOUR TIRES ARE
  - \*ALLOWS PRECISION; NO GUESSING
  - \*READS FROM 0-100 POINTS
- ★TREAD DEPTH GAUGE WITH PADDED POUCH:
  - \*CALCULATES TIRE LIFE
  - \*MEASURES 1/32" TO 14/32"



#LON 50546



#LON 50560



#LON 50555

DESCRIPTION	PART #
TIRE DUROMETER WITH CASE	LON 50546
TREAD DEPTH GAUGE WITH POUCH	LON 50560
DUROMETER & DEPTH GAUGE W/CASE	LON 50555

## TIRE LIEFS

- ★3 - 38 PSI RANGE
- ★RELIEVES PRESSURE BUILDUP
- ★WILL NOT EFFECT BALANCE
- ★SOLD AS A SET OF 4



PART #LON 50000

## TIRE LIEF INSTALLATION KIT



PART #LON 5019

- ★EASY INSTALLATION WITH DRILL BIT & 1/8" NPT TAP
- ★DRIVER SOCKET ON TAP

## TIRE LIEF SETTING TOOL

- ★SET TIRE LIEFS BEFORE INSTALLATION
- ★ACCURATELY SIMULATES TIRE PRESSURE

PART #LON 50290



YOU CAN FIND SEVERAL VARIATIONS OF TIRE SOFTENER ON PAGE 253

## PRO TIRE LIEF KIT



- ★KIT INCLUDES:
  - \*1 SETTING TOOL
  - \*6 TIRE LIEFS
  - \*12 QUICKCHANGE WHEEL ADAPTERS
  - \*1 INFLATION ADAPTER
  - \*6 PROTECTIVE COVERS
  - & \*CARRYING CASE

PART #LON 50100

## TIRE LIEF QUICK CHANGE ADAPTERS

- ★ALLOWS YOU TO REMOVE TIRE LIEFS WITHOUT LOSING TIRE PRESSURE
- ★LIGHTWEIGHT, LOW PROFILE
- ★SOLD AS A SET OF 4



PART #LON 50240

## PROTECTIVE COVERS



- ★KEEPS DIRT OUT OF TIRE LIEFS
- ★PUSH-ON TYPE
- ★EASY REMOVAL
- ★SOLD AS A SET OF 4

PART #LON 5017

## INFLATION ADAPTER

- ★ELIMINATES THE NEED TO DRILL ANOTHER HOLE IN THE RIM
- ★INSTALLS IN QUICK CHANGE ADAPTER, #50240
- ★FAST INSTALLATION



PART #LON 50220

## TOE-IN GAUGE

- ★MOST ACCURATE WAY TO MEASURE TOE-IN
- ★ACCURATE TO 1/32"
- ★MEASUREMENT CAN BE DONE BY ONE PERSON
- ★FOLDS FLAT FOR EASY STORAGE & TRAVEL

PART #LON 79620

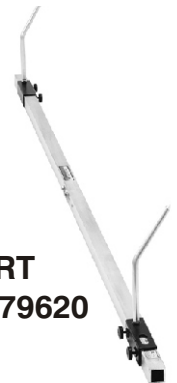

## TIRE SCRIBE

- ★SCRIBES TRUE RUNNING LINE ON TIRE FACE FOR TOE-IN SETTING
- ★SPRING LOADED
- ★EASY TO USE & VERY ACCURATE
- ★FOLDS FLAT



PART #LON 79610

Place your order at (479) 646-6988, Fax to (479) 646-5939, or visit [www.southwestspeed.com](http://www.southwestspeed.com)

# TOE-IN PLATES

- ★QUICKEST & SIMPLEST WAY TO MEASURE TOE-IN
- ★REST ONE OF THESE PLATES AGAINST THE TIRE ON EACH SIDE & MEASURE TOE DIRECTLY USING THE 2 TAPE MEASURES, WHICH ARE INCLUDED
- ★FOLDED DESIGN IS RIGID FOR ACCURACY & STAYS PUT AGAINST THE TIRE
- ★SOLD AS A PAIR WITH THE TAPE MEASURES



**PART #LON 79500**

# BUMP STEER GAUGE

- ★THIS SIMPLIFIED DESIGN USES A SINGLE PRECISION DIAL INDICATOR TO TELL YOU DIRECTLY THE EXACT AMOUNT OF BUMP STEER WITHIN .001"
- ★NO NEED TO SUBTRACT ONE DIAL READING FROM ANOTHER
- ★MOST ACCURATE, EASIEST, & QUICKEST WAY TO MEASURE YOUR CRITICAL BUMP STEER
- ★EXTENDED HEIGHT DESIGN - CHECK BUMP STEER AT RIDE HEIGHT OR ON STANDS
- ★FITS 5 x 4 1/2", 5 x 4 3/4", 5 x 5", AND WIDE 5 BOLT PATTERNS
- ★USED WITH COMMON FLOOR JACK OR BOTTLE JACK



**PART #LON 79000**

# LASER STRING

- ★THIS LASER STRING WILL ALLOW ONE PERSON TO GET THE ALIGNMENT CORRECT ON NUMEROUS PARTS OF THE CAR
- ★CAN BE USED BOTH HORIZONTAL & VERTICAL
- ★REFERENCE POINT ANYWHERE NEEDED
- ★CARRYING CASE INCLUDED



**PART #RRE 320-8983**

# TURNING PLATES

- ★1" TALL LIGHTWEIGHT ALUMINUM CONSTRUCTION
- ★READS IN 1/2° INCREMENTS
- ★NON-BINDING, FREE FLOATING IN 2 DIRECTIONS
- ★SOLD AS A SET OF 2



**PART #LON 79800**

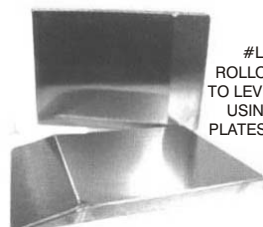

#LON 79750  
ROLLOFF SPACERS  
TO LEVEL CAR WHEN  
USING TURNING  
PLATES ON GROUND

# CASTER/CAMBER GAUGES

- ★LONGACRE CASTER/CAMBER GAUGES COME IN FOAM-PADDED, HARD ALUMINUM CASES WITH INSTRUCTIONS DETAILING HOW TO MEASURE CASTER & CAMBER
- ★GAUGES ARE VERY EASY TO READ & EXTREMELY ACCURATE
- ★MEASURE CAMBER FROM -6° TO +6°, ACCURATE TO 1/4° & MEASURE CASTER FROM -4° TO +12° IN 1/2° INCREMENTS
- ★ALL VIALS ARE INDIVIDUALLY CHECKED FOR ACCURACY & ASSEMBLED ON A PRECISION FIXTURE
- ★ALL CRITICAL SURFACES ARE CNC MACHINED FOR ACCURACY
- ★GAUGES ATTACH EASILY TO SPINDLES OR HUBS USING A NUMBER OF ADAPTERS
- ★ADAPTERS TO FIT GM, WIDE 5, STOCK CAR PRODUCTS, PINTO, FORD, & KARTING SPINDLES ARE AVAILABLE, AS WELL AS A MAGNETIC HUB ADAPTER & A BOLT-ON WIDE 5 HUB ADAPTER
- ★AVAILABLE IN ACCULEVEL DIGITAL VERSION TOO



#LON 78260



#LON 78292



DESCRIPTION	PART #
GAUGE ONLY WITH NO ADAPTER	LON 78250
GAUGE W/MAGNETIC ADAPTER	LON 78260
GAUGE W/GM SPINDLE ADAPTER	LON 78262
GAUGE W/WIDE 5 SPINDLE ADAPTER	LON 78264
GAUGE W/KARTING ADAPTER, 5/8"-18	LON 78265
GAUGE W/KARTING ADAPTER, 14mm	LON 78265-14
GAUGE W/SCP SPINDLE ADAPTER	LON 78266
GAUGE W/3/4"-16 SPINDLE ADAPTER	LON 78267
DIGITAL GAUGE ONLY, NO ADAPTER	LON 78291
DIGITAL GAUGE W/MAGNETIC ADAPT	LON 78290
DIGITAL GAUGE W/GM SPINDLE AD.	LON 78290-2
DIGITAL GAUGE W/WIDE 5 SPINDLE	LON 78290-4
DIGITAL GAUGE W/KARTING, 5/8"-18	LON 78292
DIGITAL GAUGE W/KARTING, 14mm	LON 78292-14
DIGITAL GAUGE W/QUICK SET ADAP.	LON 78295
DIGITAL GAUGE W/EXTENDED QUICK	LON 78298
MAGNETIC ADAPTER ONLY	LON 78423
WIDE 5 SPINDLE ADAPTER ONLY	LON 78405
WIDE 5 BOLT-ON HUB ADAPTER	LON 78408
GM SPINDLE ADAPTER ONLY	LON 78410
FORD PINTO SPINDLE ADAPTER	LON 78412
3/4"-16 SPINDLE ADAPTER ONLY	LON 78414
STOCK CAR PRODUCTS ADAPTER	LON 78415
KARTING ADAPTER ONLY, 5/8"-18	LON 78438
KARTING ADAPTER ONLY, 14mm	LON 78439
REPLACEMENT SHORT VIAL ONLY	LON 78244
REPLACEMENT LONG VIAL ONLY	LON 78240

Place your order at (479) 646-6988, Fax to (479) 646-5939, or visit [www.southwestspeed.com](http://www.southwestspeed.com)



## ECONOMY TIRE PYROMETER

- ★ ACCURATE, FAST RESPONSE
- ★ SIMPLE, DIGITAL DISPLAY
- ★ 1400° RANGE; °F OR °C SWITCHABLE

**PART #LON 50635**



## DIGITAL PYROMETER

- ★ ACCURATE, SUPER-FAST RESPONSE ELECTRONICS
- ★ CAN HOLD HIGHEST TEMPERATURE REACHED
- ★ COMPARES ONE TEMP. TO ANOTHER WITH THE PUSH OF A BUTTON
- ★ LOW BATTERY INDICATOR & AUTO SHUTOFF
- ★ COIL CORD TIRE PROBE
- ★ 2000° RANGE; °F OR °C SWITCHABLE
- ★ INCLUDES ALUMINUM CARRYING CASE

**PART #LON 50640**



## MEMORY PYROMETER

- ★ NIGHT LIGHT EASY-TO-READ DISPLAY
- ★ MEMORY STORES 10 SETS OF TEMPERATURES WITH EASY RECALL
- ★ DISPLAYS 12 TEMPERATURES AT ONCE
- ★ ADVANCED ELECTRONICS STABILIZE READINGS FOR CONSISTENT RESULTS
- ★ COIL CORD TIRE PROBE
- ★ INCLUDES ALUMINUM CARRYING CASE



**PART #LON 50682**

## SCALE CART

- ★ CONVENIENT STORAGE AT THE TRACK OR IN THE SHOP
- ★ CART HOLDS THE CONTROL BOX AT JUST THE RIGHT HEIGHT FOR QUICK, COMFORTABLE VIEWING
- ★ SECURES PADS DURING TRANSPORTATION

**PART #LON 72305**



## SCALE PAD LEVELERS

- ★ LIGHTWEIGHT STEEL
- ★ QUICKLY LEVELS ALL 15" ELECTRONIC SCALE PADS
- ★ 4 HEAVY-DUTY SWIVEL FEET FOR EASY LEVELING
- ★ PROVIDES AN ACCURATE SETUP ANYWHERE
- ★ SOLD AS A SET OF 4



**PART #LON 72900**

PADS NOT INCLUDED

## ELECTRONIC RACING SCALES

- ★ EXACTOWEIGH, RACEWEIGH, & PRO SERIES RACEWEIGH SCALE SYSTEMS ARE DESIGNED WITH NEW-AGE MICROCHIP TECHNOLOGY, COME IN A HARD-PROTECTIVE CASE, & COME WITH 4 DIE-CAST PADS WITH GUARANTEED ACCURACY & REPEATABILITY WITH 1/4 OF 1 PERCENT
- ★ EXACTOWEIGH SCALE SYSTEM:
  - \* COMPUTERIZED DISPLAY BOX PROVIDES ALL 4 WHEEL WEIGHTS, TOTAL WEIGHT, & A % OF ANY 2 WHEEL WEIGHTS ALL ON "FULL TIME DISPLAY"
  - \* CALCULATES CROSS, LEFT SIDE, RIGHT SIDE, FRONT, & REAR WEIGHTS
- ★ RACEWEIGH SCALE SYSTEM:
  - \* HAS ALL THE CALCULATING FEATURES OF THE EXACTOWEIGH PLUS,
  - \* 50 MEMORY STORAGE & RECALL FUNCTION
  - \* WEIGHT & % GOAL FUNCTION THAT ALLOWS YOU TO ENTER THE % DESIRED & COMPUTER CALCULATES PRECISE WHEEL WEIGHTS
  - \* COMPUTER GENERATED CENTER OF GRAVITY FUNCTION
- ★ PRO SERIES RACEWEIGH SCALE SYSTEM:
  - \* HAS ALL THE CALCULATING FEATURES & MEMORY CAPABILITIES OF THE REGULAR RACEWEIGH, PLUS
  - \* INDIVIDUAL & COMBINATION WEIGHTS DISPLAYED FULL TIME ON 6 OVERSIZED LIQUID CRYSTAL DISPLAY SCREENS



DESCRIPTION	PART #
EXACTOWEIGH SCALE SYSTEM*	790-024
RACEWEIGH SCALE SYSTEM	790-025
PRO SERIES RACEWEIGH SCALE SYSTEM	790-027
*PRINTER & CABLE (#790-032) ARE AVAILABLE FOR THE EXACTOWEIGH	

## SCALE PAD RAMPS

- ★ LIGHTWEIGHT ALUMINUM RAMPS FIT LOW PROFILE, 2 1/2" TALL PADS
- ★ MAKES AN EASY ROLL ON AND QUICK SET-UP
- ★ ADJUSTABLE LENGTH

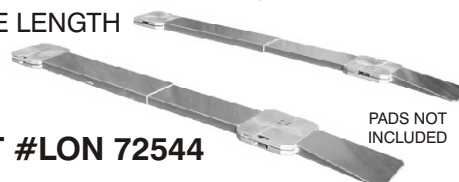

**PART #LON 72544**

PADS NOT INCLUDED

Place your order at (479) 646-6988, Fax to (479) 646-5939, or visit [www.southwestspeed.com](http://www.southwestspeed.com)



# ALUMINUM CLAMP BRACKETS

- ★LIGHTWEIGHT 7075 T-6 ALUMINUM, 2 PIECE DESIGN
- ★DESIGNED TO MOUNT NUMEROUS PARTS TO ROUND, SQUARE, OR RECTANGULAR TUBING ON THE CHASSIS
- ★TWO 1/2"-13 THREADED MOUNTING HOLES
- ★AVAILABLE IN 2 DIFFERENT DESIGNS; ONE WITH ALLEN HEAD BOLTS & ONE WITH HEX HEAD BOLTS



MOUNTS TO:		ALLEN HEAD HEX HEAD	
	DESIGN	DESIGN	DESIGN
1"	ROUND TUBE	800-310	800-3102
1 1/8"	ROUND TUBE	800-311	800-3112
1 1/4"	ROUND TUBE	800-312	800-3122
1 3/8"	ROUND TUBE	800-313	800-3132
1 1/2"	ROUND TUBE	800-314	800-3142
1 5/8"	ROUND TUBE	800-315	800-3152
1 3/4"	ROUND TUBE	800-316	800-3162
2"	ROUND TUBE	800-318	800-3182
1"	SQUARE TUBE	800-319	800-3192
1 1/2"	SQUARE TUBE	800-320	800-3202
2"	SQUARE TUBE	800-326	800-3262
2" x 3"	RECTANGLE TUBE	800-330	800-3302

\*1/2"-13 x 5" LONG MOUNTING STUD AVAILABLE, PART #800-349

# STEEL CLAMP BRACKETS

- ★LIGHTWEIGHT STEEL, 2 PIECE DESIGN
- FEATURES HEX HEAD BOLTS & ONE 1/2"-13 THREADED MOUNTING HOLE



DESCRIPTION	PART #
BRACKET FOR 1 1/4" ROUND TUBE	800-3311
BRACKET FOR 1 1/2" ROUND TUBE	800-3313
BRACKET FOR 1 5/8" ROUND TUBE	800-3314
BRACKET FOR 1 3/4" ROUND TUBE	800-3315

\*1/2"-13 x 5" LONG MOUNTING STUD AVAILABLE, PART #800-349

# LEAD WEIGHT

- ★19 LB. BLOCK OF LEAD WEIGHT WILL BE RIGHT AT 20 LB. ONCE THE MOUNTING BRACKETS & HARDWARE ARE ADDED
- ★MEASURES 2 1/2" x 2 1/2" x 8"



PART #800-350

# MOOSE BLOCKS

- ★MAGNETIC CHASSIS SETUP TOOLS
- ★3 MAGNETICS ATTACH TO CHASSIS
- ★RADIUSED TO CONTOUR TO TUBING, BUT ALSO HAVE FLATTENED AREA
- ★READS IN 1/4" OR 1/8" INCREMENTS



DESCRIPTION	STANDARD 1/4"	PRO 1/8"
BLOCKS, 1 3/4" TO 4"	790-0601	790-0612
BLOCKS, 3" TO 6"	790-0603	790-0614

# CHASSIS HEIGHT CHECKERS

- ★LIGHTWEIGHT ALUMINUM
- ★HIGHLY ACCURATE & EASY-TO-READ
- ★JUST PUSH THEM UNDER THE FRAME UNTIL THEY TOUCH



DESCRIPTION	PART #
HEIGHT CHECKER, 3 5/8" TO 6"	LON 22580
HEIGHT CHECKER, 2" TO 4"	LON 22582
HEIGHT CHECKER, 4" TO 7 1/2"	LON 22584

# ELECTRONIC SPRING TESTER

- ★TESTS SPRINGS FROM 6" - 18" TALL, COILOVER OR CONVENTIONAL
- ★RATES SPRINGS 0 - 3000 LBS. IN 1 LB. INCREMENTS
- ★MEASURES TRAVEL TO .001"
- ★COMES WITH AN EASY-TO-USE PRECISION DIAL INDICATOR TO MEASURE SPRING TRAVEL, A DIGITAL READOUT, & REMOVABLE LOAD PAD, WHICH CAN BE USED AS A PORTABLE SCALE



# CLIPBOARDS & STOPWATCHES

- ★BUILD A 1 OR 3 HEAD CLIPBOARD BY CHOOSING STOPWATCHES
- ★EACH CLIPBOARD COMES W/ A 25 SHEET RECORD PAD
- ★ASSEMBLY OF THE CLIPBOARD & STOPWATCHES IS INCLUDED
- ★STOPWATCHES CAN BE BOUGHT WITHOUT A CLIPBOARD
- ★YOU CAN SEE THE DIFFERENT FEATURES OF EACH STOPWATCH AT [www.southwestspeed.com](http://www.southwestspeed.com)

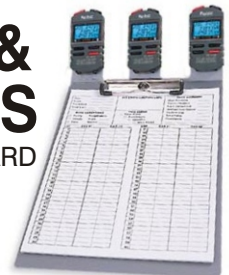

DESCRIPTION	PART #
1 HEAD CLIPBOARD WITH PAD	790-143
3 HEAD CLIPBOARD WITH PAD	790-145
ROBIC STOPWATCH MODEL SC-501	790-148
ROBIC STOPWATCH MODEL SC-505	790-150
ROBIC STOPWATCH MODEL SC-507	790-152
ROBIC STOPWATCH MODEL SC-544	790-154

Place your order at (479) 646-6988, Fax to (479) 646-5939, or visit [www.southwestspeed.com](http://www.southwestspeed.com)

# WILWOOD GP310 HARLEY BRAKE CALIPERS

- ★THESE GP310 CALIPERS ARE 4-PISTON, HIGH PERFORMANCE POWERHOUSES; THE BILLET ALUMINUM CALIPER BRINGS DISTINCTIVE, BOLT-ON STYLING TO HARLEY'S & SIMILAR BIKES
- ★THEY GIVE THE ADDED PERFORMANCE CHARACTERISTICS FOUND IN WILWOOD'S RACING CALIPERS, SUCH AS STAINLESS STEEL PISTONS TO REDUCE BRAKE FADE WHILE RESISTING CORROSION, & HIGH-TEMP PISTON SEALS FOR EXTENDED LIFE, CONTROLLED RETRACTION, & DRAG-FREE OPERATION
- ★FRONT & REAR AVAILABLE IN CHROME & POLISHED, AS WELL AS BLACK & RED COATING
- ★"BOLT PATTERN" REFERS TO THE CENTER-TO-CENTER DISTANCE ON THE 2 MOUNTING HOLES



FINISH	BOLT PATTERN	LEFT	RIGHT
<b>1984-1999 FRONT CALIPER FOR 11.50" DIAMETER ROTORS</b>			
CHROME	3.44"	WIL 120-7737	WIL 120-7736
POLISHED	3.44"	WIL 120-7737-P	WIL 120-7736-P
BLACK	3.44"	WIL 120-7737-BK	WIL 120-7736-BK
RED	3.44"	WIL 120-7737-RD	WIL 120-7736-RD
<b>2000-2007 FRONT CALIPER FOR 11.50" DIAMETER ROTORS</b>			
CHROME	2.72"	WIL 120-7739	WIL 120-7738
POLISHED	2.72"	WIL 120-7739-P	WIL 120-7738-P
BLACK	2.72"	WIL 120-7739-BK	WIL 120-7738-BK
RED	2.72"	WIL 120-7739-RD	WIL 120-7738-RD
<b>2008-2013 FRONT CALIPER FOR 11.80" DIAMETER ROTORS</b>			
CHROME	2.72"	WIL 120-12117	WIL 120-12116
POLISHED	2.72"	WIL 120-12117-P	WIL 120-12116-P
BLACK	2.72"	WIL 120-12117-BK	WIL 120-12116-BK
<b>1984-2013 REAR CALIPER FOR 11.50" DIAMETER ROTORS</b>			
CHROME	3.50"	WIL 120-7741	WIL 120-7740
POLISHED	3.50"	WIL 120-7741-P	WIL 120-7740-P
BLACK	3.50"	WIL 120-7741-BK	WIL 120-7740-BK
RED	3.50"	WIL 120-7741-RD	WIL 120-7740-RD

# WILWOOD GP310 REAR BRACKETS

- ★THE BRACKETS MOUNT WILWOOD GP310 CALIPERS ON THE RIGHT REAR OF THE HARLEY'S LISTED
- ★CHROME, POLISHED, & BLACK AVAILABLE



CHROME	POLISHED	BLACK
<b>1984-1999 HARLEY SOFTAIL WITH 11.50" ROTORS</b>		
WIL 250-8035	WIL 250-8035-P	WIL 250-8035-BK
<b>1984-1999 HARLEY DYNA WITH 11.50" ROTORS</b>		
WIL 250-8034	WIL 250-8034-P	WIL 250-8034-BK
<b>1984-1999 HARLEY DYNA-LOW MOUNT W/11.50" ROT.</b>		
WIL 250-8252	WIL 250-8252-P	WIL 250-8252-BK
<b>2000-2013 HARLEY SOFTAIL WITH 11.50" ROTORS</b>		
WIL 250-8036	WIL 250-8036-P	WIL 250-8036-BK
<b>2000-2013 HARLEY DYNA WITH 11.50" ROTORS</b>		
WIL 250-8033	WIL 250-8033-P	WIL 250-8033-BK
<b>2000-2006 HARLEY FLH/FLT WITH 11.50" ROTORS</b>		
WIL 250-10165	WIL 250-10165-P	WIL 250-10165-BK

# WILWOOD MOTORCYCLE BRAKE ROTORS

- ★WILWOOD STAINLESS ROTORS COMBINE THE ULTIMATE IN PERFORMANCE & DISTINCTIVE STYLE FOR PRODUCTION BIKES & FULL CUSTOMS USING OE DIMENSION BRAKE COMPONENTS
- ★A PROPRIETARY FINISHING PROCESS ON A SELECT STAINLESS ALLOY PROVIDES AN APPEALING, HIGH-TECH FINISH, & THE STOPPING POWER YOU EXPECT FROM WILWOOD
- ★CAN BE USED AS A DIRECT REPLACEMENT FOR 11.50" DIAMETER ROTORS, WITH OE CALIPERS OR COUPLED W/WILWOOD GP CALIPERS
- ★AVAILABLE IN STANDARD SATIN FINISH, BLACK COATED, & POLISHED
- ★.200" THICK x 11.50" DIAMETER
- ★ROTORS HAVE A 5 x 3.25" BOLT CIRCLE WITH .344" HOLES ON THE FRONT & .422" HOLES ON THE REAR
- ★THE CENTER REGISTRATION HOLE MEASURES 1.99" ON THE 1984-1999 & 2.22" ON THE 2000-2008

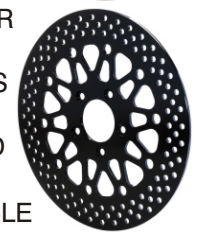
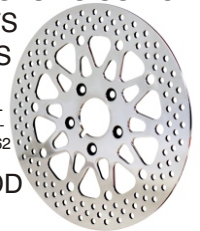

	SATIN	POLISHED	BLACK
<b>1984-1999 MOTORCYCLE FRONT ROTORS</b>			
WIL 160-10662	WIL 160-9913-P	WIL 160-10662-BK	
<b>1984-1999 MOTORCYCLE REAR ROTORS</b>			
WIL 160-10663	WIL 160-9914-P	WIL 160-10663-BK	
<b>2000-2008 MOTORCYCLE FRONT ROTORS</b>			
WIL 160-10664	WIL 160-9915-P	WIL 160-10664-BK	
<b>2000-2008 MOTORCYCLE REAR ROTORS</b>			
WIL 160-10665	WIL 160-9916-P	WIL 160-10665-BK	

# WILWOOD MASTER CYLINDERS FOOT PEDAL

- ★THESE MOTORCYCLE FOOT MASTER CYLINDERS FEATURE A HIGH QUALITY "SHOW CHROME" FINISH
- ★BILLET ALUMINUM, THIS FORWARD CONTROL CYLINDER COMES WITH AN INDUSTRY STANDARD 5/8" BORE
- ★SIDE MOUNTING HOLES ARE 2.25" CENTER-TO-CENTER



LEFT FOOT #WIL 260-10378  
RIGHT FOOT #WIL 260-10377

# HANDLEBAR

- ★WILWOOD'S 5/8" BORE HANDLEBAR MASTER CYLINDERS ARE COMPACT, LIGHTWEIGHT, & SPECIFICALLY DESIGNED FOR A VARIETY OF RECREATIONAL & SPORT/OUTDOOR APPLICATIONS
- ★CONSTRUCTED OF MATERIALS & FINISHES DESIGNED TO RESIST CORROSION, THESE CYLINDERS FIT STANDARD 7/8" DIAMETER HANDLEBARS
- ★IMPACT RESISTANT LEVER COMES WITH A 3-POSITION HYDRAULIC PARKING BRAKE LOCK



DESCRIPTION	PART #
LEFT-HAND CYLINDER	WIL 260-4201
RIGHT-HAND CYLINDER	WIL 260-4202
LEFT CYLINDER, LONG LEVER	WIL 260-11219
RIGHT CYLINDER, LONG LEVER	WIL 260-11218

Place your order at (479) 646-6988, Fax to (479) 646-5939, or visit [www.southwestspeed.com](http://www.southwestspeed.com)



## MCP MICRO-SPRINT/KARTING, MASTER CYLINDERS

- ★MCP CYLINDERS ARE GREAT FOR MICRO/MINI-SPRINTS, RACING & RECREATIONAL GO-KARTS, QUARTER MIDGETS, MINI-CUP CARS, JR. DRAGSTERS, RACING LAWN MOWERS OR BARSTOOLS



- ★THE HIGH-PERFORMANCE, CAST ALUMINUM CYLINDER BODY FEATURES ETHYL PROPYLENE SEALS, WHICH ALLOW THEM TO BE USED WITH DOT 3, DOT 4, OR DOT 5 BRAKE FLUID

DESCRIPTION	PART #
MCP CYLINDER, 3/4" BORE, RED	MCP 750
MCP CYLINDER, 3/4" BORE, BLACK	MCP 750B
MCP CYLINDER, 3/4" BORE, MACHINED	MCP 750C
MCP CYLINDER, 7/8" BORE, BLACK	MCP 875EP

## MCP MICRO-SPRINT/KARTING, BRAKE CALIPERS

- ★GREAT FOR ALL THE ABOVE LIGHT-DUTY APPLICATIONS
- ★FOR THE COMPLETE SELECTION, SEE [southwestspeed.com](http://southwestspeed.com)



## MOTORCYCLE & KARTING FRONT SPROCKETS

- ★WE HAVE FRONT SPROCKETS TO FIT HONDA, YAMAHA, KAWASAKI, SUZUKI, TRIUMPH, KTM, & HARLEY DAVIDSON BIKES
- ★THESE WILL ALSO FIT GO-KARTS & MICRO-SPRINTS THAT USE THESE BRANDS OF ENGINES
- ★FOR THE HARLEY'S, WE HAVE OE REPLACEMENT SPROCKETS, AS WELL AS OFFSET VERSIONS
- ★SEE [southwestspeed.com](http://southwestspeed.com)



## MICRO-SPRINT REAR SPROCKETS

- ★AVAILABLE FOR FACTOR 1, SAWYER, BAILEY, STALLARD, HYPER, TRIPLE X, PMP, & SIMILAR MICRO-SPRINT CHASSIS
- ★44 TO 55 TOOTH SPROCKETS AVAILABLE
- ★SEE [southwestspeed.com](http://southwestspeed.com)



## JACK STANDS

- ★3 TON JACK STANDS
- ★MINIMUM HEIGHT: 12"
- ★MAXIMUM HEIGHT: 18"
- ★DROP FORGED PEDESTAL
- ★FORMED STEEL FRAME CONSTRUCTION
- ★SOLD IN PAIRS



PART #790-120

## SPEEDY LUG WRENCH

- ★EXTRA DEEP 1" SOCKET
- ★PVC FREE-SPINNING MIDDLE HANDLE
- ★TAPERED OUTER HANDLES WITH TOUGH, RUBBER GRIPS



PART #790-010

## PIT MATS

- ★PREMIUM QUALITY, HIGH DENSITY FOAM MATS
- ★EASY CLEAN, VINYL COVERS
- ★4-FOLD MATS MEASURE 24" WIDE x 52" LONG



DESCRIPTION	PART #
SOUTHWEST SPEED PIT MAT, BLACK	760-202
SOUTHWEST SPEED PIT MAT, BLUE	760-203
SOUTHWEST SPEED PIT MAT, RED	760-204

## 200 MPH TAPE

- ★REINFORCED RACING DUCT TAPE
- ★2" WIDE x 180 FEET
- ★9 BRILLIANT COLORS
- ★STICKS QUICKLY & STAYS ON



COLOR	PART #	COLOR	PART #
WHITE	790-051	ORANGE	790-056
BLACK	790-052	GREEN	790-057
BLUE	790-053	PURPLE	790-058
RED	790-054	SILVER	790-060
YELLOW	790-055		

## RONDEL VINYL SHELF MAT



- ★GREAT FOR USE IN TRAILERS & ON SHELVES
- ★KEEPS ITEMS FROM SLIDING
- ★SOLD BY THE FOOT, 36" WIDE
- ★CUTS WITH A BOX KNIFE, BUT WON'T TEAR WITH USE

PART #800-200

Place your order at (479) 646-6988, Fax to (479) 646-5939, or visit [www.southwestspeed.com](http://www.southwestspeed.com)



# NYLON WIRE TIES

- ★EXTRA-DURABLE NYLON TIES
- ★ALLOWS YOU TO CLEAN UP LOOSE WIRES FOR SAFETY & APPEARANCE
- ★8" & 14" LONG AVAILABLE
- ★SOLD IN PACKAGES OF 100

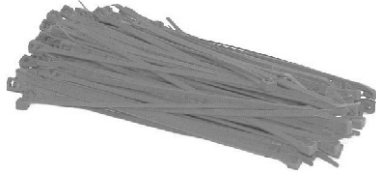

DESCRIPTION	PART #
WIRE TIES, 8" PKG. OF 100, WHITE	800-381
WIRE TIES, 8" PKG. OF 100, BLACK	800-382
WIRE TIES, 8" PKG. OF 100, BLUE	800-383
WIRE TIES, 8" PKG. OF 100, RED	800-384
WIRE TIES, 8" PKG. OF 100, YELLOW	800-385
WIRE TIES, 8" PKG. OF 100, ORANGE	800-386
WIRE TIES, 8" PKG. OF 100, PURPLE	800-388
WIRE TIES, 14" PKG. OF 100, WHITE	800-401
WIRE TIES, 14" PKG. OF 100, BLACK	800-402
WIRE TIES, 14" PKG. OF 100, BLUE	800-403
WIRE TIES, 14" PKG. OF 100, RED	800-404
WIRE TIES, 14" PKG. OF 100, YELLOW	800-405
WIRE TIES, 14" PKG. OF 100, ORANGE	800-406
WIRE TIES, 14" PKG. OF 100, GREEN	800-407
WIRE TIES, 14" PKG. OF 100, PURPLE	800-408
WIRE TIES, 14" PKG. OF 100, PINK	800-409

# ROLL BAR PADDING

- ★HIGH-DENSITY, PADDING
- ★OFFSET HOLE
- ★36" LONG STICKS
- ★SOLD INDIVIDUALLY
- ★MINIMUM ORDER OF 4 TOTAL STICKS



COLOR	PART #	COLOR	PART #
BLACK	800-152	ORANGE	800-156
BLUE	800-153	PURPLE	800-158
RED	800-154	SILVER	800-160
YELLOW	800-155		

# WINDOW CLEANER

- ★NO STREAKING OR FOGGING
- ★ANTI-STATIC
- ★GREAT FOR LEXAN, PLEXIGLASS, GLASS, & FIBERGLASS

**PART #940-080**



# WINDOW WIPES



- ★100% COTTON
- ★NON-SCRATCHING
- ★SOLD IN BAGS OF 40

**PART #940-078**

# POP RIVETS

- ★SOLD 250 RIVETS PER BOX



STANDARD 3/16" BODY, 3/8" GRIP RIVETS				
COLOR OR FINISH	SMALL (3/8") HEAD		LARGE (5/8") HEAD	
	ALUMINUM MANDREL	STEEL MANDREL	ALUMINUM MANDREL	STEEL MANDREL
MILL	800-250	800-260	800-270	800-280
WHITE		800-261		800-281
BLACK		800-262		800-282
LT. BLUE		800-263		800-283
MED. BLUE		800-274		800-294
DK. BLUE		800-273		800-293
RED		800-264		800-284
YELLOW		800-265		800-285
ORANGE		800-266		800-286
PURPLE		800-268		800-288
CUSTOM SMALL (3/8") HEAD, STEEL MANDREL				PART #
1/8" BODY, 1/4" GRIP, MILL FINISH				800-239
CUSTOM SMALL (3/8") HEAD, ALUM. MANDREL				PART #
3/16" BODY, 1/8" GRIP, MILL FINISH				800-248
3/16" BODY, 1/4" GRIP, MILL FINISH				800-249
ALUMINUM RIVET BACKUP WASHERS				PART #
SMALL HEAD BACKUP WASHERS, 250PC				800-300
LARGE HEAD BACKUP WASHERS, 250PC				800-299

# AIR RIVETERS

- ★AIR RIVETERS AVAILABLE IN A COMMERCIAL PRODUCTION MODEL, AS WELL AS SHORT & TALL LIGHT-DUTY ECONOMY MODELS



- ★1/4" NPT INLETS
- ★ALL 3 RIVETERS WILL PULL 1/8" - 3/16" RIVETS, BOTH ALUMINUM & STEEL

- ★#790-021 FEATURES A PLASTIC CONTAINER TO CAPTURE DISCARDED SHANKS & WILL PULL THE SMALLER, 3/32" RIVETS AS WELL



DESCRIPTION	PART #
COMMERCIAL POP RIVETER	790-001
LIGHT-DUTY POP RIVETER, TALL	790-002
LIGHT-DUTY POP RIVETER, SHORT	790-021

NOTE: FOR A CONSTANT STREAM OF NEW PRODUCTS & UP-TO-THE-SECOND PRICING, VISIT [WWW.SOUTHWESTSPEED.COM](http://WWW.SOUTHWESTSPEED.COM)

Place your order at (479) 646-6988, Fax to (479) 646-5939, or visit [www.southwestspeed.com](http://www.southwestspeed.com)

# HAND RIVETERS

- ★LONG, EASY-GRIP RUBBER HANDLES ARE GREAT FOR LEVERAGE
- ★FOUR HEAD SIZES
- ★WORK BEST WITH ALUMINUM SHANK RIVETS
- ★#790-023 FEATURES A HEAD THAT ADJUSTS TO DIFFERENT ANGLES



DESCRIPTION	PART #
HAND RIVETER, STANDARD HEAD	790-022
HAND RIVETER, ROTATING HEAD	790-023

# STAINLESS STEEL RIVET SPACER

- ★EXPANDABLE STAINLESS STEEL ITEM GIVES PROPER DISTANCES FOR SPACING FASTENERS

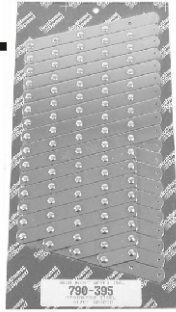

PART #790-395

# CLECO PLIERS AND FASTENERS

- ★DESIGNED TO HOLD PANELS IN PLACE DURING ASSEMBLY
- ★PLIERS & CLECOS CAN BE SOLD SEPARATELY OR IN A KIT
- ★EACH KIT INCLUDES A PAIR OF PLIERS & 25 FASTENERS



DESCRIPTION	PART #
CLECO KIT, 1/8" FASTENERS	790-327
CLECO KIT, 3/16" FASTENERS	790-329
CLECO PLIERS ONLY	790-300
1/8" CLECO FASTENER ONLY*	790-302
3/16" CLECO FASTENER ONLY*	790-304

\*FASTENERS ARE PRICED EACH & SOLD IN BAGS OF 25

# ROLL PLASTIC

- ★TOUGH & DURABLE
- ★.080" x 22" WIDE
- ★CAN BE FORMED
- ★SOLD BY THE FOOT



COLOR	PART #
WHITE	800-201
BLACK	800-202
LIGHT BLUE	800-214
DARK BLUE	800-203
RED	800-204
YELLOW	800-205
ORANGE	800-206
PURPLE	800-208
CREAM	800-211

# PANEL CLIPS

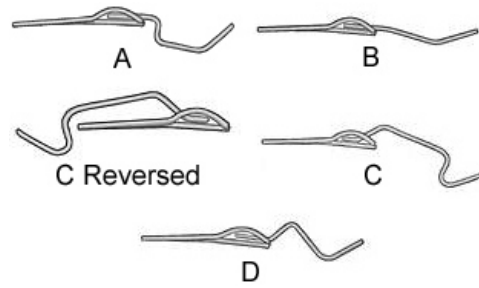

- ★PLATED STEEL CLIPS SECURE LIDS & PANELS
- ★SOLD IN PACKS OF 4 & BOXES OF 100
- ★A, B, & C REVERSED ARE SINGLE RIVET CLIPS, WHILE C & D ARE DUAL RIVET CLIPS

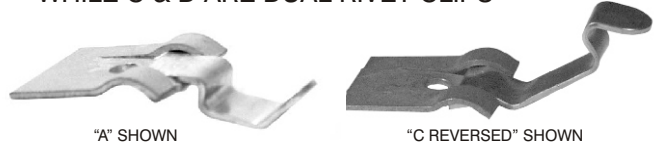

DESCRIPTION	PART #
PANEL CLIPS, PACK OF 4, "A"	710-000
PANEL CLIPS, PACK OF 4, "B"	710-004
PANEL CLIPS, PACK OF 4, "C REVERSED"	710-007
PANEL CLIPS, PACK OF 4, "C"	710-010
PANEL CLIPS, PACK OF 4, "D"	710-012
PANEL CLIPS, BOX OF 100, "A"	710-002
PANEL CLIPS, BOX OF 100, "B"	710-006
PANEL CLIPS, BOX OF 100, "C REVERSED"	710-009
PANEL CLIPS, BOX OF 100, "C"	710-011
PANEL CLIPS, BOX OF 100, "D"	710-013

# SELF EJECTING DZUS FASTENERS

- ★.500" BODY
- ★COMES COMPLETE WITH SPRING
- ★SOLD IN PACKS OF 4



PART #709-905

# SAFETY WIRE

- ★.032 STAINLESS STEEL WIRE
- ★1 LB. EASY PULL CANISTER
- ★APPROXIMATELY 360' PER CAN
- ★PREVENTS BOLTS VIBRATING LOOSE



PART #790-354

# SAFETY WIRE TWIST PLIERS

- ★END BEARING FOR SMOOTHER TWISTING
- ★9" LONG
- ★AUTOMATIC RETURN

PART #790-350



Place your order at (479) 646-6988, Fax to (479) 646-5939, or visit [www.southwestspeed.com](http://www.southwestspeed.com)

## AIR IMPACT WRENCHES

- ★3/8" & 1/2" FULL IMPACT WRENCHES, 3/8" BUTTERFLY IMPACT, & 1/2" RATCHET IMPACT AVAILABLE, AS WELL AS A COMBO WITH A 1/2" FULL WRENCH & A 3/8" RATCHET
- ★1/4" NPT INLETS



DESCRIPTION	PART #
3/8" AIR IMPACT WRENCH	705-166
1/2" AIR IMPACT WRENCH	705-174
3/8" BUTTERFLY IMPACT WRENCH	705-168
1/2" RATCHET IMPACT WRENCH	705-178
COMBO, 1/2" IMPACT & 3/8" RATCHET	705-170

## AIR CHUCK KIT, 5 PC.



- ★5 PIECE QUICK COUPLER SET
- ★ALL 1/4" NPT
- ★INCLUDES:
  - 1 FEMALE RECEPTACLE,
  - 1 FEMALE CONNECTOR, &
  - 3 MALE CONNECTORS

PART #705-158

## AIR CHUCK MANIFOLD

- ★COUPLER CROSS ASSEMBLY
- ★1/4" NPT
- ★MAKES 3 RECEPTACLES OUT OF 1

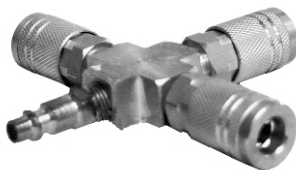

PART #705-160

## 50' AIR HOSE, 800 PSI



- ★50' LONG x 3/8" INSIDE DIAMETER RUBBER AIR HOSE
- ★1/4" NPT BRASS ENDS WITH 1 THAT SWIVELS
- ★800 PSI MAX BURST PRESSURE

PART #705-154

## ADJUSTABLE WRENCHES

- ★4 PIECE ADJUSTABLE WRENCH SET
- ★DROP-FORGED CONSTRUCTION WITH FOAM RUBBER GRIP HANDLES
- ★SIZES: 6", 8", 10", & 12"
- ★MAXIMUM JAW WIDTH:
  - 0.75" ON THE 6",
  - 1.00" ON THE 8",
  - 1.25" ON THE 10",
  - 1.49" ON THE 12"



PART #705-130

## AVIATION TIN SNIPS

- ★3 PIECE PRECISION TIN SNIP SET
- ★AVIATION TIN SNIPS ARE PRECISION TOOLS & ARE ONLY DESIGNED TO BE USED WITH THIN GAUGE METAL
- ★THERE ARE TWO 9 1/2" SNIPS, ONE RIGHT-HAND FOR CUTTING CLOCKWISE & ONE LEFT-HAND FOR CUTTING COUNTER-CLOCKWISE
- ★THE 3RD PAIR ARE 10" SNIPS THAT ARE DESIGNED TO MAKE SHORT, STRAIGHT CUTS



PART #705-120

## RAZOR BOX KNIFE SET

- ★2 PIECE FOLDING LOCKBACK UTILITY KNIFE SET
- ★FOLDABLE DESIGN FOR ONE-HAND OPERATION & COMPACT STORAGE
- ★STANDARD BLADES ALLOW EASY REPLACEMENT
- ★QUICK-LOCK MECHANISM
- ★FOR PRECISE & SAFE CUTTING
- ★10 BLADES INCLUDED
- ★CONVENIENT BELT CLIP FOR EASY STORAGE



PART #705-117

## CREEPER & ROLLER SEAT COMBO

- ★INCLUDES CREEPER & ROLLER SEAT WITH ALL NECESSARY HARDWARE
- ★FEATURES RED VINYL COVERS, STRONG STEEL FRAMES, & DURABLE CASTERS



PART #705-350

NOTE: FOR A CONSTANT STREAM OF NEW PRODUCTS & UP-TO-THE-SECOND PRICING, VISIT [WWW.SOUTHWESTSPEED.COM](http://WWW.SOUTHWESTSPEED.COM)

Place your order at (479) 646-6988, Fax to (479) 646-5939, or visit [www.southwestspeed.com](http://www.southwestspeed.com)



# HALOGEN WORK LIGHTS

- ★WORK BENCH MODEL WITH STAND, CLAMP-ON MODEL WITH 5' AC CORD, & STAND-ALONE DELUXE DUAL LAMP MODEL WITH ADJUSTABLE TRIPOD STAND AVAILABLE
- ★LIGHTS & HOUSINGS ARE DURABLE TO WITHSTAND THE JOSTLING THAT IS COMMON AROUND A WORK AREA
- ★TEMPERED GLASS LENS ARE DESIGNED NOT TO SHATTER
- ★STAND ALONE LIGHT HAS TWO 500 WATT BULBS ON AN ADJUSTABLE TRIPOD STAND



DESCRIPTION	PART #
BENCH WORK LIGHT, 150 WATT	705-280
CLAMP-ON MODEL, 150 WATT	705-282
STAND ALONE MODEL, 1000 WATT	705-284

# TOW ROPE

- ★5/8" x 14 FOOT TOW ROPE
- ★POLY-BRAID FOR EXTRA STRENGTH; APPROXIMATELY 4500 LBS.
- ★EXCELLENT STRETCH TO ABSORB SUDDEN SHOCK
- ★100% ROT RESISTANT & HANDY TO STORE
- ★2 HEAVY-DUTY FORGED STEEL HOOKS (4" LONG x 2 1/2" WIDE) WITH PLASTIC GUARDS



**PART #705-322**

# RATCHET TIE-DOWNS

- ★HEAVY-DUTY TIE-DOWNS FASTEN LOADS TIGHTLY, SAFELY, & SECURELY
- ★QUICK AUTOMATIC RELEASE
- ★STRONG 10,000 LB. NYLON WEBBING
- ★2" WIDE x 27" LONG
- ★SOLD EACH



**PART #705-330**

# RUBBER BUNGEE STRAPS

- ★STRONG RUBBER STRAPS IN LENGTHS 9" TO 31"
- ★SOLD EACH

DESCRIPTION	PART #
RUBBER STRAP, 9"	790-849
RUBBER STRAP, 15"	790-850
RUBBER STRAP, 22"	790-851
RUBBER STRAP, 31"	790-852



# NYLON CLAMP KIT

- ★10 PIECE NYLON SPRING CLAMP KIT IS GREAT FOR HOLDING ALMOST ANYTHING TOGETHER AROUND THE SHOP OR AT THE TRACK
- ★VINYL COVERED TIPS
- ★HEAVY-DUTY TEMPERED SPRINGS
- ★COMFORTABLE PLASTIC HANDLES



**PART #705-202**

# WELDING CLAMP KITS

- ★#705-224 IS AN 8 7/8" LONG x 2 5/8" WIDE x 1 7/8" TALL MAGNETIC CLAMP THAT CAN BE PLACED AT ANY ANGLE & LOCKED IN THAT POSITION
- ★#705-228 IS A 10 PIECE MULTI-PURPOSE KIT THAT INCLUDES TWO-360° ADJUSTABLE MAGNET HOLDERS, FOUR-45°, 90°, & 135° ARROW MAGNET HOLDERS (2 - 50 LB. & 2 - 75 LB. CAPACITY), THREE-LOCKING WELDING CLAMPS, & ONE-MAGNETIC WELD GROUND

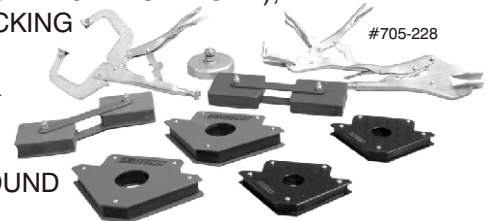

DESCRIPTION	PART #
ANGLED MAGNETIC CLAMP	705-224
10 PC. MULTI-PURPOSE CLAMP KIT	705-228

# 4" VISES

- ★4" DRILL PRESS VISE ELIMINATES THE NEED FOR SPECIAL JIGS & IT FEATURES STEEL JAW FACES, COLD-ROLLED STEEL SCREW, CAST IRON BASE, & A SWIVEL CRANK HANDLE THAT DROPS OUT OF THE WAY
- \*JAW SIZE: 4 1/8" x 1/4" x 3/4"
- \*BASE SIZE: 6 1/2" x 6 1/2"
- \*MAXIMUM JAW OPENING: 3 1/8"
- ★4" BENCH VISE FEATURES A 360° SWIVEL LOCKING BASE, HEAVY-DUTY STEEL CONSTRUCTION, AND HARDENED & POLISHED JAW & ANVIL

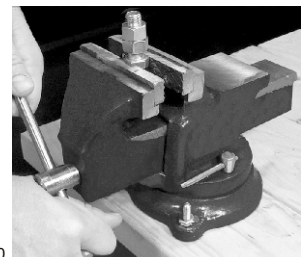
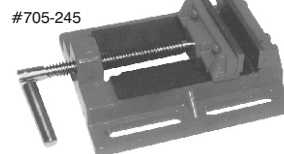

DESCRIPTION	PART #
4" DRILL PRESS VISE	705-245
4" BENCH VISE	705-240

Place your order at (479) 646-6988, Fax to (479) 646-5939, or visit [www.southwestspeed.com](http://www.southwestspeed.com)

# 4 TON PORTA POWER

- ★4 TON PUMP & RAM STORES EASILY IN DURABLE BLOW MOLD CASE
- ★GREAT FOR ALL FRAME & BODY WORK
- ★4 HEAVY WALLED EXTENSION TUBES STAND UP TO ALMOST ANY JOB
- ★1/2 TON SPREADER
- ★90° V-BASE
- ★FLEX & WEDGE HEADS
- ★SERRATED SADDLE
- ★MALE CONNECTORS
- ★6' HOSE WITH CONNECTORS
- ★PLUNGER & TOW RAMS



**PART #705-340**

# 10 TON PORTA POWER

- ★10 TON PORTA POWER & RAM COMES IN STORAGE CASE & IS GREAT FOR FRAME & BODY WORK
- ★DUCK-BILL SPREADER
- ★5", 10", 18", & 27" EXTENSION TUBES
- ★FLAT BASE
- ★90° V-BASE
- ★3 1/4" FLEX HEAD
- ★WEDGE HEAD
- ★PLUNGER TO COLLAR TOE
- ★HYDRAULIC HOSE
- ★SERRATED SADDLE



**PART #705-342**

# FENDER / BODY SUPPORTS

- ★FLEXIBLE SUPPORTS MADE FROM LIGHTWEIGHT, BREAK-RESISTANT MATERIAL
- ★EACH SUPPORT CAN BE CUT TO LENGTH, BUT THE #23740 ALSO GIVES 4 1/2" OF ADJUSTMENT ONCE IN PLACE
- ★SUPPORTS WILL SPRING BACK TO SHAPE
- ★INCLUDES ALL HARDWARE FOR A QUICK & PROFESSIONAL INSTALLATION
- ★SOLD IN PAIRS



DESCRIPTION	PART #
SUPPORT KIT, CUT-TO-LENGTH (2)	LON 23720
SUPPORT KIT, ADJUSTABLE (2)	LON 23740

# HOOD PINS

- ★POLISHED & ANODIZED ALUMINUM & CHROME PLATED STEEL AVAILABLE
- ★1/2"-20 THREADS
- ★KITS COME WITH 2 PINS, 2 SCUFF PLATES, 2 CLIPS (EITHER FLIP OVER OR HAIR PIN), & EITHER 4 JAM NUTS OR 2 JAM NUTS & 2 THREADED WELD BOSSES



ALUMINUM KITS WITH FLIP CLIPS	W/ ALL JAM NUTS	W/ NUTS & BOSSES
POLISHED ALUMINUM	710-099	N/A
ANODIZED ALUM., GOLD	710-101	710-111
ANODIZED ALUM., BLACK	710-102	710-112
ANODIZED ALUM., BLUE	710-103	710-113
ANODIZED ALUM., RED	710-104	710-114
STEEL KITS WITH HAIR PIN CLIPS	W/ ALL JAM NUTS	W/ NUTS & BOSSES
CHROME PLATED STEEL	710-100	710-115

HOOD PIN KITS ARE AVAILABLE IN BULK LOTS OF 50 PIECES. ADD "B" TO END OF PART # WHEN ORDERING BULK. BULK KITS ARE PRICED EACH, INSTEAD OF IN PAIRS. #710-101B WOULD BE 1 GOLD PIN, 1 SCUFF PLATE, 1 FLIP CLIP, & 2 JAM NUTS. #710-111B WOULD BE 1 GOLD PIN, 1 SCUFF PLATE, 1 FLIP CLIP, 1 JAM NUT, & 1 WELDING BOSS.

INDIVIDUAL PARTS (SOLD EACH)	PART #
HOOD PIN STUD ONLY, CHROME, STEEL	710-120
HOOD PIN STUD ONLY, GOLD, ALUM.	710-121
HOOD PIN STUD ONLY, BLACK, ALUM.	710-122
HOOD PIN STUD ONLY, BLUE, ALUM.	710-123
HOOD PIN STUD ONLY, RED, ALUM.	710-124
FLIP OVER CLIP ONLY	710-110
HAIR PIN CLIP ONLY	710-107
ALUMINUM SCUFF PLATE ONLY	710-109
THREADED WELDING BOSS ONLY	710-108
1/2" HEX JAM NUT	987-918

# DECAL KIT

- ★10 PAIR (20 TOTAL) OF ASSORTED DECALS FROM THE TOP NAMES IN THE RACING INDUSTRY
- ★KIT COMES ON A HANGING CARD FOR DISPLAY IN RETAIL STORES



**PART #790-170**

# SHOP TOWELS

- ★12" x 23" SHOP SWABBYS
- ★SOLD IN PACKS OF 50



**PART #940-072**

Place your order at (479) 646-6988, Fax to (479) 646-5939, or visit [www.southwestspeed.com](http://www.southwestspeed.com)

# LEXAN SPOILERS

- ★5 PIECE CLEAR OR TINTED
- ★ADJUSTABLE DESIGN
- ★5" OR 8" TALL
- ★69" OR 72" WIDE

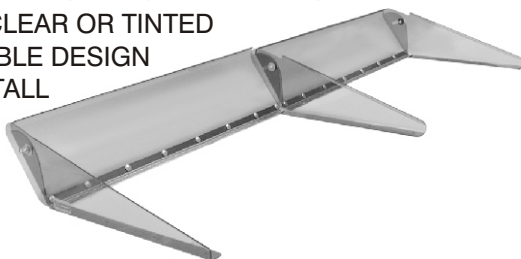

DESCRIPTION	PART #
5" x 72", 5 PIECE SPOILER, CLEAR	SWS B-999850
5" x 72", 5 PIECE SPOILER, TINTED	SWS B-999851
8" x 69", 5 PIECE SPOILER, CLEAR	SWS B-999869
8" x 69", 5 PIECE SPOILER, TINTED	SWS B-999870
8" x 72", 5 PIECE SPOILER, CLEAR	SWS B-999872
8" x 72", 5 PIECE SPOILER, TINTED	SWS B-999873

# FIBERGLASS ROOFS CAVALIER STYLE

- ★FITS MOST MODIFIEDS
- ★MEASURES 46" WIDE x 50" LONG
- ★REINFORCED FIBERGLASS CONSTRUCTION
- ★EXTREMELY DURABLE

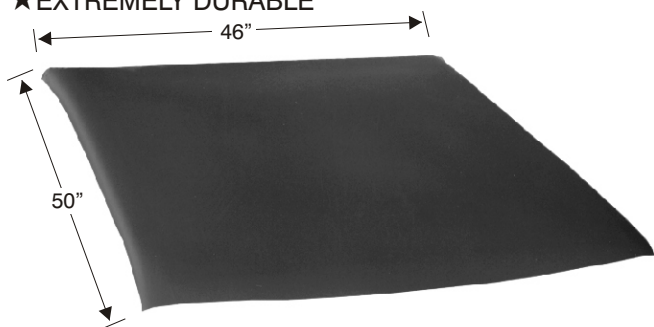

DESCRIPTION	PART #
FIBERGLASS ROOF, WHITE	SWS B-400
FIBERGLASS ROOF, BLACK	SWS B-402
FIBERGLASS ROOF, LIGHT BLUE	SWS B-403
FIBERGLASS ROOF, DARK BLUE	SWS B-413
FIBERGLASS ROOF, RED	SWS B-404
FIBERGLASS ROOF, YELLOW	SWS B-405
FIBERGLASS ROOF, ORANGE	SWS B-406

# OUTLAW GREMLIN STYLE

- ★MEASURES 45" WIDE x 57" LONG WITH A 2" RAISED LIP ON THE REAR OF ROOF
- ★REINFORCED FIBERGLASS CONSTRUCTION
- ★EXTREMELY DURABLE

DESCRIPTION	PART #
FIBERGLASS ROOF, WHITE	SWS B-420
FIBERGLASS ROOF, BLACK	SWS B-422
FIBERGLASS ROOF, DARK BLUE	SWS B-433
FIBERGLASS ROOF, RED	SWS B-424
FIBERGLASS ROOF, YELLOW	SWS B-425
FIBERGLASS ROOF, ORANGE	SWS B-426

NOTE: FOR A CONSTANT STREAM OF NEW PRODUCTS & UP-TO-THE-SECOND PRICING, VISIT [WWW.SOUTHWESTSPEED.COM](http://WWW.SOUTHWESTSPEED.COM)

# NOSEPIECES 1970-81 CAMARO



SHOWN WITH HEADLIGHT & ID KIT

DESCRIPTION	PART #
70-81 CAMARO UPPER, WHITE	SWS B-200720
70-81 CAMARO UPPER, BLACK	SWS B-200722
70-81 CAMARO UPPER, BLUE	SWS B-200723
70-81 CAMARO UPPER, RED	SWS B-200724
70-81 CAMARO UPPER, YELLOW	SWS B-200725
70-81 CAMARO UPPER, ORANGE	SWS B-200726
70-81 CAMARO HEADLIGHT & ID KIT	SWS B-201722

# 1970-81 CAMARO LOWER SPOILER - BLACK ONLY

PART #SWS B-200824



# 1992 IROC-Z



DIRT-STYLE NOSEPIECE SHOWN

SHOWN WITH HEADLIGHT & ID KIT

DESCRIPTION	PART #
1992 IROC-Z DIRT, WHITE	SWS B-200191
1992 IROC-Z DIRT, BLACK	SWS B-200192
1992 IROC-Z DIRT, PEPSI BLUE	SWS B-200193
1992 IROC-Z DIRT, RED	SWS B-200194
1992 IROC-Z DIRT, YELLOW	SWS B-200195
1992 IROC-Z DIRT, ORANGE	SWS B-200196
1992 IROC-Z DIRT, CHEVRON BLUE	SWS B-200198
1992 IROC-Z PAVEMENT, WHITE*	SWS B-200061
1992 IROC-Z PAVEMENT, BLACK**	SWS B-200302
1992 IROC-Z PAVEMENT, RED**	SWS B-200304
1992 HEADLIGHT KIT	SWS B-201191
1992 HEADLIGHT & ID KIT	SWS B-201192

\*#200061 PAVEMENT NOSE MEASURES:

21" TALL x 68" WIDE ON THE TOP x 79" WIDE ON THE BOTTOM

\*\*#200302 & #200304 PAVEMENT NOSES MEASURE:

21" TALL x 72" WIDE ON THE TOP x 84" WIDE ON THE BOTTOM

# OUTLAW FORD PROBE

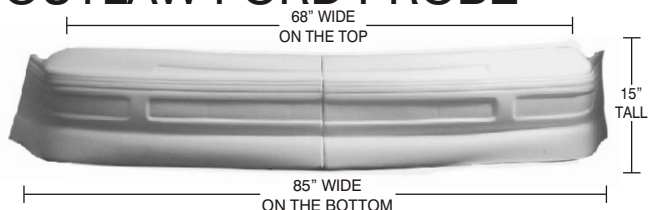

PART #SWS B-250

Place your order at (479) 646-6988, Fax to (479) 646-5939, or visit [www.southwestspeed.com](http://www.southwestspeed.com)



# BILLET SPECIALTIES TRU-TRAC FRONT ENGINE KITS

- ★ BILLET SPECIALTIES TRU-TRAC SERPENTINE SYSTEMS ARE THE MOST COMPLETE SYSTEMS ON THE MARKET
- ★ THEY ARE ENGINEERED TO BOLT RIGHT ON & ALIGN PERFECTLY WITHOUT THE NEED FOR STABILIZER BRACKETS OR ADJUSTER BARS
- ★ CNC MACHINED & POLISHED TO A MIRROR FINISH, THE TRU-TRAC NOT ONLY LOOKS AWESOME, BUT IT PERFORMS
- ★ TRU-TRACS INCREASE EFFICIENCY BY ELIMINATING BELT SLIPPAGE
- ★ QUALITY IS ABUNDANT IN EVERY ASPECT OF EACH TRU-TRAC SYSTEM
- ★ EVERY BRACKET & PULLEY IS MACHINED FROM 6061-T6 BILLET ALUMINUM FOR EXCEPTIONAL STRENGTH & RIGIDITY
- ★ KITS INCLUDE EDELBROCK WATER PUMP, POLISHED ALTERNATOR, POLISHED BRACKETS & TENSIONER, ALL POLISHED PULLEYS & FASTENERS, AS WELL AS POWER STEERING PUMP & POLISHED A/C COMPRESSOR IN SELECT KITS
- ★ PREMIUM (P, PA, WP, & WPA) KITS ARE AVAILABLE WITH UPGRADED ENDURA-SHINE WATER PUMP, POLISHED POWER STEERING PUMP, OR UPGRADED BILLET-CASE ALTERNATOR (SEE CHART)
- ★ SEVERAL CONFIGURATIONS ALSO AVAILABLE WITH BLACK PULLEYS, BRACKETS, & TENSIONERS, INSTEAD OF POLISHED
- ★ MUCH MORE DETAIL AT [southwestspeed.com](http://southwestspeed.com)



BSI 13125

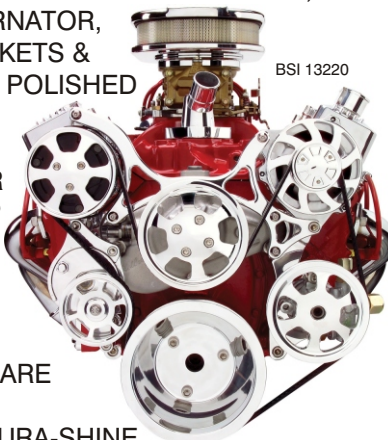

BSI 13220

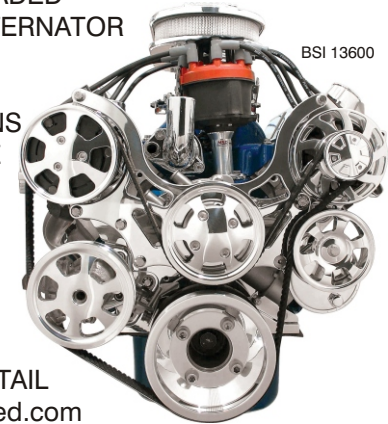

BSI 13600

ENGINE	WATER PUMP	ALTERNAT.	A.C. COMP.	POW. ST.	PART #	BLACK #
SBC	NATURAL	POLISHED	-	-	BSI 13125	BSI BLK13125
SBC	ENDURA-SHINE	POLISHED	-	-	BSI 13125W	-
SBC	ENDURA-SHINE	POL/BILLET	-	-	BSI 13125WA	-
SBC	NATURAL	POLISHED	POLISHED	-	BSI 13120	BSI BLK13120
SBC	ENDURA-SHINE	POLISHED	POLISHED	-	BSI 13120W	-
SBC	ENDURA-SHINE	POL/BILLET	POLISHED	-	BSI 13120WA	-
SBC	NATURAL	POLISHED	-	NATURAL	BSI 13225	BSI BLK13225
SBC	ENDURA-SHINE	POLISHED	-	POLISHED	BSI 13225WP	-
SBC	ENDURA-SHINE	POL/BILLET	-	POLISHED	BSI 13225WPA	-
SBC	NATURAL	POLISHED	POLISHED	NATURAL	BSI 13220	BSI BLK13220
SBC	ENDURA-SHINE	POLISHED	POLISHED	POLISHED	BSI 13220WP	BSI BLK13220WP
SBC	ENDURA-SHINE	POL/BILLET	POLISHED	POLISHED	BSI 13220WPA	BSI BLK13220WPA
BBB	NATURAL	POLISHED	-	-	BSI 14125	BSI BLK14125
BBB	ENDURA-SHINE	POLISHED	-	-	BSI 14125W	-
BBB	ENDURA-SHINE	POL/BILLET	-	-	BSI 14125WA	-
BBB	NATURAL	POLISHED	POLISHED	-	BSI 14120	BSI BLK14120
BBB	ENDURA-SHINE	POLISHED	POLISHED	-	BSI 14120W	-
BBB	ENDURA-SHINE	POL/BILLET	POLISHED	-	BSI 14120WA	-
BBB	NATURAL	POLISHED	-	NATURAL	BSI 14225	BSI BLK14225
BBB	ENDURA-SHINE	POLISHED	-	POLISHED	BSI 14225WP	-
BBB	ENDURA-SHINE	POL/BILLET	-	POLISHED	BSI 14225WPA	-
BBB	NATURAL	POLISHED	POLISHED	NATURAL	BSI 14220	BSI BLK14220
BBB	ENDURA-SHINE	POLISHED	POLISHED	POLISHED	BSI 14220WP	BSI BLK14220WP
BBB	ENDURA-SHINE	POL/BILLET	POLISHED	POLISHED	BSI 14220WPA	BSI BLK14220WPA
CHEVY 348/409	NATURAL	POLISHED	-	-	BSI 14425	BSI BLK14425
CHEVY 348/409	ENDURA-SHINE	POLISHED	-	-	BSI 14425W	-
CHEVY 348/409	ENDURA-SHINE	POL/BILLET	-	-	BSI 14425WA	-
CHEVY 348/409	NATURAL	POLISHED	POLISHED	-	BSI 14420	BSI BLK14420
CHEVY 348/409	ENDURA-SHINE	POLISHED	POLISHED	-	BSI 14420W	-
CHEVY 348/409	ENDURA-SHINE	POL/BILLET	POLISHED	-	BSI 14420WA	-
CHEVY 348/409	NATURAL	POLISHED	-	NATURAL	BSI 14405	BSI BLK14405
CHEVY 348/409	ENDURA-SHINE	POLISHED	-	POLISHED	BSI 14405WP	-
CHEVY 348/409	ENDURA-SHINE	POL/BILLET	-	POLISHED	BSI 14405WPA	-
CHEVY 348/409	NATURAL	POLISHED	POLISHED	NATURAL	BSI 14400	BSI BLK14400
CHEVY 348/409	ENDURA-SHINE	POLISHED	POLISHED	POLISHED	BSI 14400WP	BSI BLK14400WP
CHEVY 348/409	ENDURA-SHINE	POL/BILLET	POLISHED	POLISHED	BSI 14400WPA	BSI BLK14400WPA
LS-1, 2, 3, & 6	NATURAL	POLISHED	-	-	BSI 13475	BSI BLK13475
LS-1, 2, 3, & 6	NATURAL	POL/BILLET	-	-	BSI 13475A	-
LS-1, 2, 3, & 6	NATURAL	POLISHED	POLISHED	-	BSI 13470	BSI BLK13470
LS-1, 2, 3, & 6	NATURAL	POL/BILLET	POLISHED	-	BSI 13470A	-
LS-1, 2, 3, & 6	NATURAL	POLISHED	-	NATURAL	BSI 13455	BSI BLK13455
LS-1, 2, 3, & 6	NATURAL	POLISHED	-	POLISHED	BSI 13455P	-
LS-1, 2, 3, & 6	NATURAL	POL/BILLET	-	POLISHED	BSI 13455PA	-
LS-1, 2, 3, & 6	NATURAL	POLISHED	POLISHED	NATURAL	BSI 13450	BSI BLK13450
LS-1, 2, 3, & 6	NATURAL	POLISHED	POLISHED	POLISHED	BSI 13450P	BSI BLK13450P
LS-1, 2, 3, & 6	NATURAL	POL/BILLET	POLISHED	POLISHED	BSI 13450PA	BSI BLK13450PA
LS-7	NATURAL	POLISHED	-	-	BSI 13495	BSI BLK13495
LS-7	NATURAL	POL/BILLET	-	-	BSI 13495A	-
LS-7	NATURAL	POLISHED	POLISHED	-	BSI 13490	BSI BLK13490
LS-7	NATURAL	POL/BILLET	POLISHED	-	BSI 13490A	-
LS-7	NATURAL	POLISHED	-	NATURAL	BSI 13465	BSI BLK13465
LS-7	NATURAL	POLISHED	-	POLISHED	BSI 13465P	-
LS-7	NATURAL	POL/BILLET	-	POLISHED	BSI 13465PA	-
LS-7	NATURAL	POLISHED	POLISHED	NATURAL	BSI 13460	BSI BLK13460
LS-7	NATURAL	POLISHED	POLISHED	POLISHED	BSI 13460P	BSI BLK13460P
LS-7	NATURAL	POL/BILLET	POLISHED	POLISHED	BSI 13460PA	BSI BLK13460PA
SB FORD	NATURAL	POLISHED	-	-	BSI 13625	BSI BLK13625
SB FORD	NATURAL	POL/BILLET	-	-	BSI 13625A	-
SB FORD	NATURAL	POLISHED	POLISHED	-	BSI 13620	BSI BLK13620
SB FORD	NATURAL	POL/BILLET	POLISHED	-	BSI 13620A	-
SB FORD	NATURAL	POLISHED	-	NATURAL	BSI 13605	BSI BLK13605
SB FORD	NATURAL	POLISHED	-	POLISHED	BSI 13605P	-
SB FORD	NATURAL	POL/BILLET	-	POLISHED	BSI 13605PA	-
SB FORD	NATURAL	POLISHED	POLISHED	NATURAL	BSI 13600	BSI BLK13600
SB FORD	NATURAL	POLISHED	POLISHED	POLISHED	BSI 13600P	BSI BLK13600P
SB FORD	NATURAL	POL/BILLET	POLISHED	POLISHED	BSI 13600PA	BSI BLK13600PA
BB FORD	NATURAL	POLISHED	-	-	BSI 14625	BSI BLK14625
BB FORD	NATURAL	POL/BILLET	-	-	BSI 14625A	-
BB FORD	NATURAL	POLISHED	POLISHED	-	BSI 14620	BSI BLK14620
BB FORD	NATURAL	POL/BILLET	POLISHED	-	BSI 14620A	-
BB FORD	NATURAL	POLISHED	-	NATURAL	BSI 14605	BSI BLK14605
BB FORD	NATURAL	POLISHED	-	POLISHED	BSI 14605P	-
BB FORD	NATURAL	POL/BILLET	-	POLISHED	BSI 14605PA	-
BB FORD	NATURAL	POLISHED	POLISHED	NATURAL	BSI 14600	BSI BLK14600
BB FORD	NATURAL	POLISHED	POLISHED	POLISHED	BSI 14600P	BSI BLK14600P
BB FORD	NATURAL	POL/BILLET	POLISHED	POLISHED	BSI 14600PA	BSI BLK14600PA
SB CHRYSLER	NATURAL	POLISHED	-	-	BSI 13825	BSI BLK13825
SB CHRYSLER	NATURAL	POL/BILLET	-	-	BSI 13825A	-
SB CHRYSLER	NATURAL	POLISHED	POLISHED	-	BSI 13820	BSI BLK13820
SB CHRYSLER	NATURAL	POL/BILLET	POLISHED	-	BSI 13820A	-
SB CHRYSLER	NATURAL	POLISHED	-	NATURAL	BSI 13805	BSI BLK13805
SB CHRYSLER	NATURAL	POLISHED	-	POLISHED	BSI 13805P	-
SB CHRYSLER	NATURAL	POL/BILLET	-	POLISHED	BSI 13805PA	-
SB CHRYSLER	NATURAL	POLISHED	POLISHED	NATURAL	BSI 13800	BSI BLK13800
SB CHRYSLER	NATURAL	POLISHED	POLISHED	POLISHED	BSI 13800P	BSI BLK13800P
SB CHRYSLER	NATURAL	POL/BILLET	POLISHED	POLISHED	BSI 13800PA	BSI BLK13800PA
BB CHRY/HEMI	NATURAL	POLISHED	-	-	BSI 14825	BSI BLK14825
BB CHRY/HEMI	NATURAL	POL/BILLET	-	-	BSI 14825A	-
BB CHRY/HEMI	NATURAL	POLISHED	POLISHED	-	BSI 14820	BSI BLK14820
BB CHRY/HEMI	NATURAL	POL/BILLET	POLISHED	-	BSI 14820A	-
BB CHRY/HEMI	NATURAL	POLISHED	-	NATURAL	BSI 14805	BSI BLK14805
BB CHRY/HEMI	NATURAL	POLISHED	-	POLISHED	BSI 14805P	-
BB CHRY/HEMI	NATURAL	POL/BILLET	-	POLISHED	BSI 14805PA	-
BB CHRY/HEMI	NATURAL	POLISHED	POLISHED	NATURAL	BSI 14800	BSI BLK14800
BB CHRY/HEMI	NATURAL	POLISHED	POLISHED	POLISHED	BSI 14800P	BSI BLK14800P
BB CHRY/HEMI	NATURAL	POL/BILLET	POLISHED	POLISHED	BSI 14800PA	BSI BLK14800PA
SB/BB PONTIAC	NATURAL	POLISHED	-	-	BSI 14925	BSI BLK14925
SB/BB PONTIAC	NATURAL	POL/BILLET	-	-	BSI 14925A	-
SB/BB PONTIAC	NATURAL	POLISHED	POLISHED	-	BSI 14920	BSI BLK14920
SB/BB PONTIAC	NATURAL	POL/BILLET	POLISHED	-	BSI 14920A	-
SB/BB PONTIAC	NATURAL	POLISHED	-	NATURAL	BSI 14905	BSI BLK14905
SB/BB PONTIAC	NATURAL	POLISHED	-	POLISHED	BSI 14905P	-
SB/BB PONTIAC	NATURAL	POL/BILLET	-	POLISHED	BSI 14905PA	-
SB/BB PONTIAC	NATURAL	POLISHED	POLISHED	NATURAL	BSI 14900	BSI BLK14900
SB/BB PONTIAC	NATURAL	POLISHED	POLISHED	POLISHED	BSI 14900P	BSI BLK14900P
SB/BB PONTIAC	NATURAL	POL/BILLET	POLISHED	POLISHED	BSI 14900PA	BSI BLK14900PA

Place your order at (479) 646-6988, Fax to (479) 646-5939, or visit [www.southwestspeed.com](http://www.southwestspeed.com)

# BILLET SPECIALTIES CHEVY SERPENTINE CONVERSION KITS

- ★ THESE KITS INCLUDE THE BRACKETS & PULLEYS TO CONVERT SBC & BBC TO SERPENTINE
- ★ KITS DON'T INCLUDE THE ACTUAL ALTERNATOR, WATER OR P.S. PUMPS, A/C COMPRESSOR, OR BELTS; ONLY THE POLISHED BRACKETS, PULLEYS, & BOLTS
- ★ FITS LONG WATER PUMPS, GM 10SI OR 12SI ALTERNATORS, SAGINAW TYPE 1 P.S. PUMPS (BOTH PRESS-ON & KEYWAY AVAILABLE), & SANDEN 508 A/C COMPRESSORS
- ★ KITS EITHER MOUNT THE ALTERNATOR TO THE TOP OR MIDDLE PASSENGER'S SIDE
- ★ BILLET QUALITY, FIT, & FINISH ARE ENGINEERED INTO THESE CONVERSION KITS

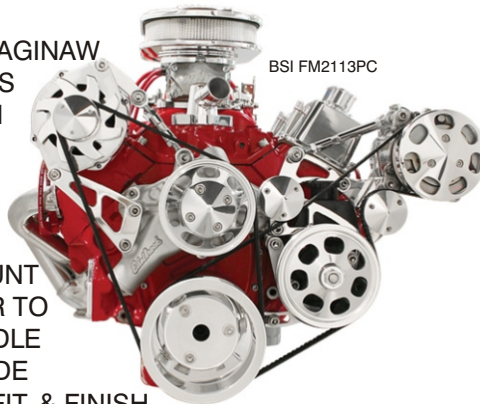
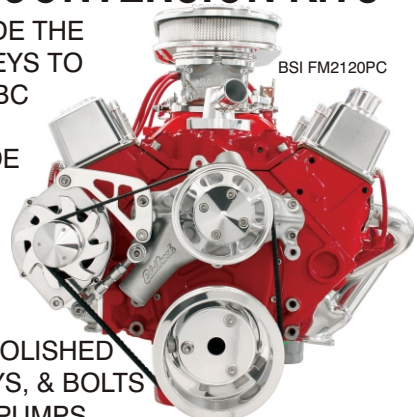

- ★ ALL BRACKETS & PULLEYS ARE MACHINED FROM 6061-T6 BILLET ALUM. & POLISHED TO A MIRROR FINISH
- ★ MUCH MORE DETAIL AT southwest speed.com

ENGINE	ALT.	A/C	POW. ST.	PART #
SBC	TOP	-	-	BSI FM2110PC
SBC	TOP	-	KEYWAY	BSI FM2111PC
SBC	TOP	-	PRESS-ON	BSI FM2112PC
SBC	TOP	YES	KEYWAY	BSI FM2113PC
SBC	TOP	YES	PRESS-ON	BSI FM2114PC
SBC	MID	-	-	BSI FM2120PC
SBC	MID	-	KEYWAY	BSI FM2121PC
SBC	MID	-	PRESS-ON	BSI FM2122PC
BBC	TOP	-	-	BSI FM2210PC
BBC	TOP	-	KEYWAY	BSI FM2211PC
BBC	TOP	-	PRESS-ON	BSI FM2212PC
BBC	TOP	YES	KEYWAY	BSI FM2213PC
BBC	TOP	YES	PRESS-ON	BSI FM2214PC
BBC	MID	-	-	BSI FM2220PC
BBC	MID	-	KEYWAY	BSI FM2221PC
BBC	MID	-	PRESS-ON	BSI FM2222PC

# POWER STEERING HOSE KIT FOR TRU-TRAC KITS

- ★ THIS KIT IS DESIGNED TO BE USED WITH TRU-TRAC SYSTEMS, BUT WILL WORK WITH OTHER POWER STEERING SYSTEMS AS WELL
- ★ EACH KIT IS SUPPLIED WITH ENOUGH ADAPTERS TO COVER MOST POPULAR GM BOXES & FORD-TYPE RACK
- ★ QUALITY FITTINGS & HOSE ARE USED TO ENSURE RELIABILITY



**PART #**  
**BSI 77900**

# BILLET SPECIALTIES POLISHED V-BELT PULLEYS

- ★ BILLET PULLEYS ARE CNC MACHINED FROM FORGED 6061-T6 ALUMINUM FOR THE ULTIMATE IN STRENGTH & BALANCE
- ★ DESIGNED FOR USE WITH V-GROOVE STYLE BELTS ON CHEVY ENGINES
- ★ EACH PULLEY IS POLISHED TO A MIRROR FINISH



DESCRIPTION	PART #
LONG WATER PUMP PULLEY, SBC/BBC, 1 GROOVE	BSI 78110
LONG WATER PUMP PULLEY, SBC/BBC, 2 GROOVE	BSI 78120
SHORT WATER PUMP PULLEY, SBC, 1 GROOVE	BSI 80120
SHORT WATER PUMP PULLEY, SBC, 2 GROOVE	BSI 80220
SHORT WATER PUMP PULLEY, BBC, 1 GROOVE	BSI 82120
SHORT WATER PUMP PULLEY, BBC, 2 GROOVE	BSI 82220
LONG WATER PUMP NOSE CONE	BSI 84220
SHORT WATER PUMP NOSE CONE	BSI 84120
CRANK PULLEY FOR SBC LONG W.P., 1 GROOVE	BSI 78210
CRANK PULLEY FOR SBC LONG W.P., 2 GROOVE	BSI 78220
CRANK PULLEY FOR SBC LONG W.P., 3 GROOVE	BSI 78230
CRANK PULLEY FOR SBC SHORT W.P., 1 GROOVE	BSI 81120
CRANK PULLEY FOR SBC SHORT W.P., 2 GROOVE	BSI 81220
CRANK PULLEY FOR SBC SHORT W.P., 3 GROOVE	BSI 81320
CRANK PULLEY FOR BBC LONG W.P., 1 GROOVE	BSI 79210
CRANK PULLEY FOR BBC LONG W.P., 2 GROOVE	BSI 79220
CRANK PULLEY FOR BBC LONG W.P., 3 GROOVE	BSI 79230
CRANK PULLEY FOR BBC SHORT W.P., 1 GROOVE	BSI 83120
CRANK PULLEY FOR BBC SHORT W.P., 2 GROOVE	BSI 83220
CRANK PULLEY FOR BBC SHORT W.P., 3 GROOVE	BSI 83320
POWER STEERING PULLEY, KEYWAY, 1 GROOVE	BSI 86120
POWER STEERING PULLEY, KEYWAY, 2 GROOVE	BSI 86220
POWER STEERING PULLEY, PRESS-ON, 1 GROOVE	BSI 86420
POWER STEERING PULLEY, PRESS-ON, 2 GROOVE	BSI 86520
ALTERNATOR PULLEY, MOST GM, FORD, DELCO	BSI 85120
ALTERNATOR PULLEY WITH FAN, MOST GM, FORD..	BSI 85220
AC COMP CLUTCH COVER, SANDEN 508	BSI 87120
AC COMP CLUTCH COVER, SANDEN SD-7	BSI 87220
POWER STEERING PULLEY, KEYWAY, SERPENTINE	BSI FM1030PC
POWER STEERING PULLEY, PRESS, SERPENTINE	BSI FM1035PC

# POWER STEERING RESERVOIRS FOR BILLET TRU-TRAC KITS

- ★ DESIGNED TO BE USED WITH TRU-TRAC SYSTEMS, BUT WILL WORK WITH OTHER POWER STEERING SYSTEMS AS WELL
- ★ THE DOUBLE O-RING SEALED BREATHABLE CAP RELIEVES POSITIVE & NEGATIVE PRESSURE WHILE KEEPING THE ENGINE COMPARTMENT CLEAN
- ★ INTERNALLY BAFFLED TO PREVENT SPLASH OVER
- ★ BILLET ALUMINUM, POLISHED TO A MIRROR FINISH, ALSO AVAILABLE IN BLACK ANODIZED



DESCRIPTION	PART #
REMOTE RESERVOIR, POLISHED, SMOOTH	BSI 77910
REMOTE RESERVOIR, POLISHED, RIBBED	BSI 77920
REMOTE RESERVOIR, BLACK, SMOOTH	BSI BLK77910
BOLT-ON RESERVOIR, POLISHED	BSI 77930
BOLT-ON RESERVOIR, BLACK	BSI BLK77930

Place your order at (479) 646-6988, Fax to (479) 646-5939, or visit [www.southwestspeed.com](http://www.southwestspeed.com)



## REAR VIEW MIRRORS WIDE ANGLE - PANEL TYPE

- ★4 PANEL MIRROR COMES WITH MOUNTING KIT

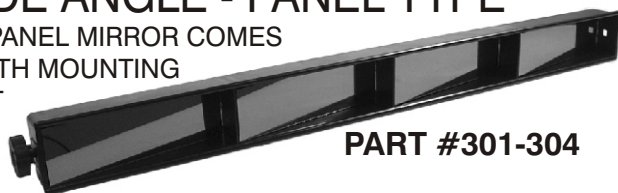

**PART #301-304**

## WIDE ANGLE - CONVEX TYPE

- ★14" & 17" WIDE MIRROR KITS COME COMPLETE WITH TWO CLAMP-ON BRACKETS THAT ADJUST 3 1/2" UP & DOWN & FIT EITHER 1 1/2" OR 1 3/4" ROUND TUBING

- ★KITS MAKE A QUICK, NEAT INSTALLATION & THEY WON'T VIBRATE LOOSE



DESCRIPTION	PART #
14" WIDE MIRROR KIT, 1 1/2" BAR	LON 22537
14" WIDE KIT, 1 3/4" BAR, 1/2"-2 1/2"	LON 22534
14" WIDE KIT, 1 3/4" BAR, 2" - 5 1/2"	LON 22536
17" WIDE MIRROR KIT, 1 1/2" BAR	LON 22533
17" WIDE MIRROR KIT, 1 3/4" BAR	LON 22532

## ROUND SPOT MIRRORS CLAMP-ON KITS

- ★3 3/4" DIAMETER SPOT MIRROR KITS INCLUDE AN ADJUSTABLE BRACKET TO CLAMP ON EITHER 1 1/2" OR 1 3/4" ROUND TUBING

- ★ADJUSTABLE DESIGN ENABLES THE MIRROR TO BE USED ALMOST ANYWHERE IN THE CAR TO REGAIN ANY LOST FIELD OF VISION

- ★LOCKS SOLIDLY IN PLACE INSURING VIBRATION WON'T AFFECT ADJUSTMENT



DESCRIPTION	PART #
CLAMP-ON SPOT MIRROR KIT, 1 1/2"	LON 22549
CLAMP-ON SPOT MIRROR KIT, 1 3/4"	LON 22548

## HELMET HOOKS

- ★LIGHTWEIGHT ALUMINUM HOOKS CLAMP ON EITHER 1 1/2" OR 1 3/4" ROUND TUBING

- ★HOOKS ALLOWS HELMET OR OTHER ACCESSORIES TO BE HUNG INSIDE CAR WHEN NOT IN USE

- ★AVAILABLE IN A FIXED & A SWIVELING DESIGN

- ★SWIVELING HOOK ALLOWS THE HELMET TO BE MOVED OUT OF THE WAY WHEN WORKING INSIDE THE CAR



DESCRIPTION	PART #
FIXED HELMET HOOK, 1 1/2" BAR	LON 22572
FIXED HELMET HOOK, 1 3/4" BAR	LON 22570
SWIVEL HELMET HOOK, 1 1/2" BAR	LON 22573
SWIVEL HELMET HOOK, 1 3/4" BAR	LON 22571

## FIRE BRAIDED SLEEVING

- ★HIGH TEMPERATURE, FLEXIBLE INSULATING SLEEVING WILL NOT BURN
- ★SILICON-COATED FIBERGLASS BRAID HELPS PREVENT HEADERS FROM BURNING OTHER ITEMS UNDER THE HOOD
- ★PROTECTS PLUG WIRES, BATTERY CABLES, FUEL & OIL LINES, AND OTHER WIRING



DESCRIPTION	PART #
BRAID SLEEVING, 5/16" I.D. x 3' LONG	LON 49500
BRAID SLEEVING, 3/8" I.D. x 3' LONG	LON 49600
BRAID SLEEVING, 9/16" I.D. x 3' LONG	LON 49700
BRAID SLEEVING, 11/16" I.D. x 3' LONG	LON 49750
BRAID SLEEVING, 13/16" I.D. x 3' LONG	LON 49800
BRAID SLEEVING, 15/16" I.D. x 3' LONG	LON 49850
BRAID SLEEVING, 1 1/8" I.D. x 3' LONG	LON 49900

## INSULATING FLOOR MATS

- ★SPECIALLY DESIGNED FOR USE IN THE DRIVER'S COMPARTMENT
- ★MADE OF FIREPROOF, NON-ASBESTOS, HEAVYWEIGHT CLOTH
- ★SILICON-COATED ON ONE SIDE & ALUMINIZED FOR HEAT REFLECTION ON THE OTHER
- ★IN THE MIDDLE IS A HEAVY-DUTY, HIGH-TEMPERATURE INSULATION MATERIAL
- ★MOUNTS EASILY WITH RIVETS OR SCREWS USING EYELETS IN THE CORNERS

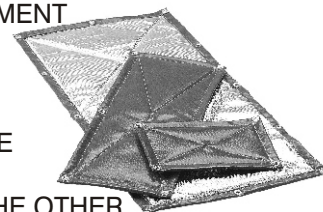

DESCRIPTION	PART #
INSULATING FLOOR MAT, 8" x 12"	LON 64420
INSULATING FLOOR MAT, 10" x 24"	LON 64400
INSULATING FLOOR MAT, 18" x 18"	LON 64360
INSULATING FLOOR MAT, 18" x 24"	LON 64320

## HEADER WRAP

- ★SOLD IN 2" WIDE x 1/16" THICK ROLLS, EITHER 50' OR 100' LONG
- ★CONTAINS EXHAUST HEAT FOR BETTER VELOCITY & SCAVENGING MORE POWER, PLUS COOLER UNDER-HOOD TEMPERATURES
- ★ALSO USED TO INSULATE MUFFLERS, EXHAUST COLLECTORS & PIPES, OIL & FUEL LINES



DESCRIPTION	PART #
1/16" THICK x 2" WIDE x 50 FT. LONG	LON 64870
1/16" THICK x 2" WIDE x 100 FT. LONG	LON 64850

## ROLL BAR PADDING

- ★HIGH-DENSITY, PADDING
- ★OFFSET HOLE; 36" LONG STICKS
- ★SOLD INDIVIDUALLY; MINIMUM ORDER



OF 4 TOTAL STICKS	COLOR	PART #	COLOR	PART #
	BLACK	800-152	ORANGE	800-156
BLUE	800-153	PURPLE	800-158	
RED	800-154	SILVER	800-160	
YELLOW	800-155			

Place your order at (479) 646-6988, Fax to (479) 646-5939, or visit [www.southwestspeed.com](http://www.southwestspeed.com)



# GAUGE PANELS & ACCESSORY PARTS

★BRUSHED ALUMINUM GAUGE PANELS WITH OIL PRESSURE & WATER TEMPERATURE, AS WELL AS FUEL PRESSURE & OIL TEMPERATURE ON THE 3 & 4 GAUGE PANELS



#390-100

★EACH 2 5/8" DIAMETER GAUGE IS COLOR CODED



#390-101

★THE PANELS ARE PRE-WIRED FOR EASY INSTALLATION & COME WITH



#390-103

WARNING LIGHTS & SENDING UNITS

GAUGE PANELS	PART #
2 GAUGE PANEL, O.P., W.T.	390-100
3 GAUGE PANEL, O.P., W.T., F.P.	390-101
4 GAUGE PANEL, O.P., W.T., F.P., O.T.	390-103
INDIVIDUAL GAUGES	PART #
FUEL PRESSURE GAUGE, 0-15 PSI	390-405
OIL PRESSURE GAUGE, 0-100 PSI	390-406
WATER TEMP. GAUGE, 100°-265°	390-409
OIL TEMP. GAUGE, 140°-325°	390-410
SENDERS & OTHER PARTS	PART #
FUEL PRESSURE SENDER, 4 1/2 PSI	390-505
OIL PRESSURE SENDER, 20 PSI	390-506
WATER TEMP. SENDER, 230°	390-509
OIL TEMP. SENDER, 270°	390-510
TEMP. GAUGE ADAPTER, 1/2" NPT	390-411
GAUGE BACK LIGHT & WIRE ASSY.	390-490

# WARNING LIGHT KITS

★WARNING LIGHT KITS INCLUDE LIGHT WITH LENS, SENDER, AND NECESSARY WIRE & TERMINALS



GAUGE LIGHT ASSEMBLIES

WARNING LIGHT KITS	PART #
FUEL PRESSURE, 4 1/2 PSI, CLEAR LENS	390-625
OIL PRESSURE, 20 PSI, RED LENS	390-626
WATER TEMP., 230°, AMBER LENS	390-629
OIL TEMPERATURE, 270°, GREEN LENS	390-630
GAUGE LIGHT ASSEMBLIES ONLY	PART #
CLEAR LENS WITH BULB & HOUSING	390-605
RED LENS WITH BULB & HOUSING	390-606
BLUE LENS WITH BULB & HOUSING	390-608
AMBER LENS WITH BULB & HOUSING	390-609
GREEN LENS WITH BULB & HOUSING	390-610

# SWITCH PANELS

- ★BRUSHED ALUMINUM SWITCH PANELS FOR STANDARD & MAGNETO IGNITIONS
- ★WATER-RESISTANT PANELS COME PRE-WIRED FOR EASY INSTALLATION
- ★AVAILABLE IN SEVERAL DIFFERENT CONFIGURATIONS & ACCESSORIES
- ★ALL PANELS WILL ACCEPT AIRCRAFT-TYPE FLIP COVERS



DESCRIPTION	PART #
STANDARD, TOGGLE - BUTTON	390-200
STANDARD, TOGGLE - BUTTON - LIGHT	390-205
STANDARD, 2 TOGGLES - 1 BUTTON	390-210
MAGNETO, TOGGLE - BUTTON	390-201
MAGNETO, 2 TOG.- 1 BUTTON - 2 LIGHTS	390-216

# SWITCH PANEL PARTS

★PARTS TO REPLACE BROKEN OR WORN OUT SWITCH PANEL ACCESSORIES



★INCLUDES HEAVY-DUTY, RUBBER COVERED STARTER BUTTON AND HEAVY-DUTY STANDARD & MAGNETO TOGGLE SWITCHES WITH DUST COVERS



★BRIGHT RED AIRCRAFT FLIP COVER IS ALSO AVAILABLE



DESCRIPTION	PART #
HEAVY-DUTY STARTER BUTTON, PUSH	390-250
STANDARD IGNITION SWITCH, ON/OFF	390-254
MAGNETO IGNITION SWITCH, ON/OFF	390-255
IGNITION SWITCH DUST COVER ONLY	390-259
AIRCRAFT-TYPE FLIP COVER ONLY, RED	390-260

# GAUGE LINE KITS



- ★CONNECTS OIL OR FUEL GAUGES TO THE ENGINE
- ★LINE KITS INCLUDE: \*-4 AN STEEL BRAIDED HOSE, \*1/8" NPT MALE TO -4 AN BLOCK FITTING, & \*1/8" NPT FEMALE TO -4 AN GAUGE FITTING

DESCRIPTION	PART #
24" GAUGE LINE KIT	390-002
36" GAUGE LINE KIT	390-003
48" GAUGE LINE KIT	390-004
1/8" NPT FEMALE TO -4 AN FITTING ONLY	301-001
1/8" NPT MALE TO -4 AN FITTING ONLY	301-003

Place your order at (479) 646-6988, Fax to (479) 646-5939, or visit [www.southwestspeed.com](http://www.southwestspeed.com)

## DELUXE GAUGE & PANEL KITS



### ★KITS INCLUDE:

- \*2 OR 3 GAUGE PANEL,
- \*DUAL MINI-BRAKE GAUGE PANEL,
- \*SWITCH PANEL FOR STANDARD IGNITION WITH 1 TOGGLE, 1 BUTTON, & 1 LIGHT, AND
- \*MASTER BATTERY DISCONNECT PANEL

DESCRIPTION	PART #
DELUXE KIT WITH 2 GAUGE PANEL	390-120
DELUXE KIT WITH 3 GAUGE PANEL	390-121

## TACHOMETERS

### DIGITAL RACING TACHOMETER

- ★BACK LIT DISPLAY
- ★MEMORY OF THE LAST 3 HIGH RPM'S
- ★3 1/2" WIDE X 3 1/4" TALL
- ★CHECKS BATTERY VOLTAGE
- ★PROVIDES ON-SCREEN HELP
- ★INCLUDES WIRING HARNESS & MOUNTING BRACKET



**PART #390-150**

### LONGACRE DIGITAL TACHS

- ★ACCUTECH, EASY RECALL TACHS
- ★ULTRA-LIGHTWEIGHT AT ONLY 1.5 OUNCES
- ★3 1/2" WIDE X 1 1/2" TALL
- ★HIGH RPM WARNING LIGHT
- ★ACCURATE WITHIN 10 RPM'S UP TO EITHER 10K OR 19K RPM



DESCRIPTION	PART #
DIGITAL TACH, UP TO 10,000 RPM	LON 44391
DIGITAL TACH, UP TO 19,000 RPM	LON 44402

### 5" O.D. MEMORY RECALL TACHS

- ★NEEDLE READING ELECTRIC TACHS WITH A 5" DIAMETER FACE READ RPM'S UP TO 11,000
- ★FEATURES MEMORY RECALL OF HIGHEST RPM
- ★THESE NEWER GENERATION, SLIM DESIGN TACHS ARE 35% THINNER & 30% LIGHTER THAN COMPETITIVE MODELS
- ★MODEM TOUCH PAD CONTROLS
- ★USED ON ALL 4, 6, & 8 CYL. ENGINES
- ★INCLUDE MOUNTING BRACKETS
- ★#PRF 67004C HAS AN ADJUSTABLE INTERNAL SHIFT LIGHT



DESCRIPTION	PART #
5" O.D. RECALL TACH	PRF 67002C
5" O.D. RECALL TACH W/ INT. SHIFT LT.	PRF 67004C

## BRAKE GAUGES

- ★0 TO 2000 PSI
- ★INSTANT PRESSURE
- ★2 5/8" DIAMETER GAUGE FACES
- ★INCLUDES BLEEDER FITTINGS & 1/8" NPT TEE FITTINGS
- ★INDIVIDUAL GAUGES AVAILABLE (#390-193)



**PART #390-195**

## MINI BRAKE GAUGES

- ★0 TO 1500 PSI FRONT & REAR
- ★LIQUID FILLED TO STEADY NEEDLE FUNCTION
- ★1 1/2" DIAMETER GAUGE FACES
- ★INCLUDES 2 BLEEDERS AT THE BACK OF GAUGE FOR EASY BLEEDING
- ★INDIVIDUAL GAUGES AVAILABLE (#390-191)



**PART #390-192**

## MASTER BATTERY DISCONNECTS SWITCH & PANEL

- ★POWER SAFETY SHUTOFF
- ★FITS IN BATTERY CABLE
- ★LARGE, EASILY ACCESSIBLE HANDLE
- ★EASY-TO-READ PANEL



**PART #390-091**

## ECONOMY

- ★POWER SAFETY SHUTOFF
- ★FITS IN BATTERY CABLE
- ★REMOVABLE KEY-LIKE HANDLE
- ★REPLACEMENT HANDLES ARE AVAILABLE (PART #390-0879)



**PART #390-088**

## BATTERY CABLES

- ★HEAVY DUTY 1/0 CABLE
- ★PROVIDES MORE CRANKING AMP CAPABILITY
- ★REDUCES VOLTAGE DROP
- ★AVAILABLE IN RED OR BLACK
- ★PRICED PER FOOT
- ★MINIMUM ORDER OF 15 FOOT



DESCRIPTION	PART #
BLACK 1/0 BATTERY CABLE	499-960
RED 1/0 BATTERY CABLE	499-961

NOTE: FOR A CONSTANT STREAM OF NEW PRODUCTS & UP-TO-THE-SECOND PRICING, VISIT [WWW.SOUTHWESTSPEED.COM](http://WWW.SOUTHWESTSPEED.COM)

Place your order at (479) 646-6988, Fax to (479) 646-5939, or visit [www.southwestspeed.com](http://www.southwestspeed.com)



# BATTERY CABLE KITS

- ★AVAILABLE FOR TOP POST & SIDE POST BATTERIES, WITH OR WITHOUT MASTER DISCONNECT PANELS
- ★1/0 WELDING CABLE FOR HIGH CURRENT FLOW
- ★HEAVY DUTY TERMINAL ENDS ARE MADE OF CAST BRASS
- ★COMPRESSION DESIGN MAKES ENDS REUSABLE
- ★NYLON WIRE CLAMPS INCLUDED FOR SAFE & NEAT WIRING INSTALLATION

#499-961 RED 1/0 CABLE, 15' INCLUDED IN EACH KIT



#499-960 BLACK 1/0 CABLE, 2' INCLUDED IN EACH KIT



#499-923  
TOP POST  
BATTERY TERMINALS  
2 INCLUDED IN  
KIT #499-970 &  
KIT #499-974



#900-269  
NYLON WIRE CLAMPS  
16 INCLUDED IN EACH KIT

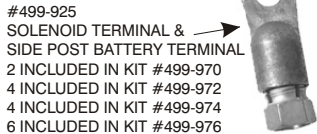

#499-925  
SOLENOID TERMINAL &  
SIDE POST BATTERY TERMINAL  
2 INCLUDED IN KIT #499-970  
4 INCLUDED IN KIT #499-972  
6 INCLUDED IN KIT #499-974  
6 INCLUDED IN KIT #499-976

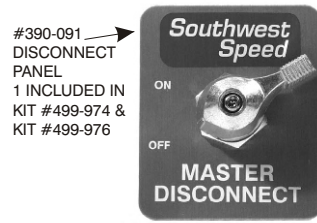

#390-091  
DISCONNECT  
PANEL  
1 INCLUDED IN  
KIT #499-974 &  
KIT #499-976

DESCRIPTION	PART #
KIT FOR TOP POST BATTERY	499-970
KIT FOR SIDE POST BATTERY	499-972
KIT WITH DISCONNECT FOR TOP POST	499-974
KIT WITH DISCONNECT FOR SIDE POST	499-976

# ADEL LINE CLAMPS

- ★ENABLES NEAT & SAFE INSTALLATION OF HOSES & WIRES
- ★CLAMPS FEATURE HIGH TEMPERATURE, NEOPRENE LINING
- ★SOLD IN PACKS OF 10 OR BOXES OF 100

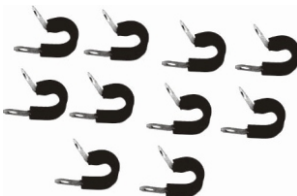

DESCRIPTION	PACK OF 10	BOX OF 100
ADEL CLAMPS, -3	900-203	900-233
ADEL CLAMPS, -4	900-204	900-234
ADEL CLAMPS, -5	900-205	900-235
ADEL CLAMPS, -6	900-206	900-236
ADEL CLAMPS, -7	900-207	900-237
ADEL CLAMPS, -8	900-208	900-238
ADEL CLAMPS, -9	900-209	900-239
ADEL CLAMPS, -10	900-210	900-240
ADEL CLAMPS, -11	900-211	900-241
ADEL CLAMPS, -12	900-212	900-242
ADEL CLAMPS, -15	900-215	900-245
ADEL CLAMPS, -17	900-217	900-247
ADEL CLAMPS, -19	900-219	900-249
ADEL CLAMPS, -20	900-220	900-250
NYLON CLAMPS, -3	N/A	900-253
NYLON CLAMPS, -9	N/A	900-269

# WIRING ACCESSORIES

## TERMINAL BLOCKS

- ★2 & 8 GANG TERMINAL BLOCKS
- ★RATING: 30A, 600V, UL & CSA
- ★CENTER SPACING: 9/16"
- ★TERMINAL SIZE: 0.250"
- ★DISTANCE BETWEEN BARRIERS: 0.412"
- ★TEMPERATURE RANGE OF -40° TO 260° F
- ★WIRE SIZE: #10-22 AWG



DESCRIPTION	PART #
TERMINAL BLOCK, 2 GANG	390-1432
TERMINAL BLOCK, 8 GANG	390-1438

## TERMINALS

- ★BOTH PUSH-ON & 8 STUD RING TERMINALS
- ★THESE ARE THE MOST ECONOMICAL INSULATED TERMINALS AVAILABLE
- ★PVC INSULATED SLEEVE IS SECURELY FASTENED TO THE BUTTON SEAM BARREL
- ★INSULATION HAS A FLARED ENTRY FOR EASIER WIRE INSERTION
- ★PRICED & SOLD IN PACKS OF 100



DESCRIPTION	PART #
16-14 GAUGE, FEMALE PUSH-ON TERM.	390-2920
16-14 GAUGE, 8 STUD RING TERMINALS	390-2620
12-10 GAUGE, 8 STUD RING TERMINALS	390-2720

## QUICK SPLICE CONNECTOR

- ★16-14 GAUGE QUICK SPLICE CONNECTOR IS USED FOR QUICK CONNECTIONS WITH NO WIRE STRIPPING
- ★SIMPLY INSERT BOTH WIRES, SQUEEZE DOWN THE METAL INSERT WITH PLIERS & SNAP THE COVER IN PLACE
- ★PRICED & SOLD IN PACKS OF 100



PART #390-2820

## 10 AMP AGC FUSES

- ★10 AMP FUSES
- ★PRICED & SOLD IN PACKS OF 10



PART #390-1446

## FUSE RETAINER WITH PANEL MOUNT

- ★PANEL MOUNT FUSE RETAINER
- ★10 AMP FUSE INCLUDED
- ★DESIGNED TO MOUNT IN PANEL HOLE OF 0.506" DIAMETER



PART #390-1457

Place your order at (479) 646-6988, Fax to (479) 646-5939, or visit [www.southwestspeed.com](http://www.southwestspeed.com)



# KIRKEY ALUMINUM RACING SEATS

## ECONOMY SEATS - LAYBACK & UPRIGHT

- ★20° LAYBACK & 10° UPRIGHT SEATS WITH DUAL RIB SUPPORTS
- ★.125" THICK, 5052 GRADE ALUMINUM CONSTRUCTION
- ★SEAT BOTTOM CONTOURED TO SUPPORT LOWER BACK & HIPS
- ★HEADREST REINFORCED WITH OFFSET ALUMINUM EXTRUSION
- ★PRE-CUT SEAT BELT SLOTS
- ★CLIP-ON (OR HOOK-ON) HIGH-DENSITY FOAM, WATER RESISTANT NYLON COVERS
- ★SEATS & COVERS SOLD SEPARATELY



## INTERMEDIATE SEATS - LAYBACK & UPRIGHT

- ★20° LAYBACK & 10° UPRIGHT SEATS WITH DUAL RIB SUPPORTS
- ★.125" THICK, 5052 GRADE ALUMINUM CONSTRUCTION
- ★PRE-CUT SEAT BELT SLOTS
- ★SEAT BOTTOM CONTOURED IN REAR FOR MULTI-ANGLED SEAT POSITION MOUNTING
- ★RAISED IN FRONT FOR THIGH SUPPORT
- ★SNAP-ON, HIGH-DENSITY FOAM, CLOTH COVERS
- ★SEATS & COVERS ARE SOLD SEPARATELY



THE TERM "UPRIGHT" IS AN INDUSTRY TERM FOR SEATS THAT ARE ACTUALLY 10° LAYBACK

KIRKEY ECONOMY SEATS ONLY	PART #
14 1/2" WIDE 20° LAYBACK ECONOMY	KIR 09200
15 1/2" WIDE 20° LAYBACK ECONOMY	KIR 09400
17 1/2" WIDE 20° LAYBACK ECONOMY	KIR 09800
14 1/2" WIDE 10° UPRIGHT ECONOMY	KIR 19200
15 1/2" WIDE 10° UPRIGHT ECONOMY	KIR 19400
17 1/2" WIDE 10° UPRIGHT ECONOMY	KIR 19800

COVERS ONLY FOR BOTH LAYBACK & UPRIGHT			
WIDTH	BLACK	BLUE	RED
14 1/2" - 10° & 20°	KIR 09401	KIR 09403	KIR 09402
15 1/2" - 10° & 20°	KIR 09401	KIR 09403	KIR 09402
17 1/2" - 10° & 20°	KIR 09801	KIR 09803	KIR 09802

\*14 1/2" & 15 1/2" SEATS USE THE SAME COVERS

KIRKEY INTERMEDIATE SEATS ONLY		PART #
14" WIDE 20° LAYBACK SEAT		KIR 36100
15" WIDE 20° LAYBACK SEAT		KIR 36300
16" WIDE 20° LAYBACK SEAT		KIR 36500
17" WIDE 20° LAYBACK SEAT		KIR 36700
18" WIDE 20° LAYBACK SEAT		KIR 36900
20" WIDE 20° LAYBACK SEAT		KIR 36800
14" WIDE 10° UPRIGHT SEAT		KIR 39100
15" WIDE 10° UPRIGHT SEAT		KIR 39300
16" WIDE 10° UPRIGHT SEAT		KIR 39500
17" WIDE 10° UPRIGHT SEAT		KIR 39700
18" WIDE 10° UPRIGHT SEAT		KIR 39900

COVERS ONLY FOR BOTH LAYBACK & UPRIGHT				
WIDTH	BLACK	BLUE	RED	GRAY
14"	KIR 36111	KIR 36119	KIR 36112	KIR 36117
15"	KIR 36311	KIR 36319	KIR 36312	KIR 36317
16"	KIR 36511	KIR 36519	KIR 36512	KIR 36517
17"	KIR 36711	KIR 36719	KIR 36712	KIR 36717
18"	KIR 36911	KIR 36919	KIR 36912	KIR 36917
20"	KIR 36811	KIR 36819	KIR 36812	KIR 36817

## ECONOMY DRAG RACING SEATS

- ★20° LAYBACK FOR DRAG RACING
- ★MIG WELDED .125" THICK, 5052 GRADE ALUMINUM CONSTRUCTION
- ★SEAT BOTTOM CONTOURED TO SUPPORT LOWER BACK & HIPS
- ★HEADREST REINFORCED WITH OFFSET ALUMINUM EXTRUSION
- ★SEATS & CLOTH COVERS SOLD SEPARATELY



KIRKEY ECONOMY DRAG SEATS ONLY	PART #
15 1/2" WIDE 20° LAYBACK SEAT	KIR 16400
17 1/2" WIDE 20° LAYBACK SEAT	KIR 16800

COVERS ONLY		
WIDTH	BLACK	GRAY
15 1/2" CLOTH	KIR 16411	KIR 16417
17 1/2" CLOTH	KIR 16811	KIR 16817

HOW TO MEASURE FOR A SEAT: IN THE SEATED POSITION, USING 2 STRAIGHT EDGES, MEASURE ACROSS THE HIPS AT THE WIDEST POINT. THIS MEASUREMENT IS THE WIDTH OF SEAT THAT YOU NEED.

WE HAVE SEVERAL OTHER SERIES OF KIRKEY SEATS AVAILABLE, AS WELL AS A COMPLETE LINE OF SEAT MOUNTING TABS. VISIT [www.southwestspeed.com](http://www.southwestspeed.com) TO SEE THE FULL SELECTION

## INTERMEDIATE ROAD RACE SEATS

- ★15° LAYBACK FOR ROAD RACE
- ★TIG WELDED .125" THICK, 5052 GRADE ALUMINUM
- ★PRE-CUT SEAT BELT SLOTS
- ★A TRUE ROAD RACE DESIGN WITH BUILT-IN SHOULDER SUPPORT & EXTRA MATERIAL AT RIB HEIGHT PROVIDES SUPPORT FOR HIGH G-FORCE CORNERING BUT IS DESIGNED TO NOT INTERFERE WITH SHIFTING
- ★SEATS & COMPLETE HIGH-DENSITY FOAM PADDED COVERS ARE SOLD SEPARATELY



INTERMEDIATE ROAD RACE SEAT ONLY		PART #		
15" WIDE ROAD RACE SEAT		KIR 47300		
16" WIDE ROAD RACE SEAT		KIR 47500		
17" WIDE ROAD RACE SEAT		KIR 47700		
18" WIDE ROAD RACE SEAT		KIR 47900		
COVERS	15"	16"	17"	18"
BLACK	KIR 47341	KIR 47541	KIR 47741	KIR 47941

Place your order at (479) 646-6988, Fax to (479) 646-5939, or visit [www.southwestspeed.com](http://www.southwestspeed.com)

# KIRKEY ALUMINUM RACING SEATS

## LIGHTWEIGHT SEATS - LAYBACK & UPRIGHT

- ★20° LAYBACK & 10° UPRIGHT SEATS WITH DUAL RIB SUPPORTS
- ★.081" THICK, 5052 GRADE ALUMINUM
- ★STRATEGICALLY PLACED FLARED HOLES SAVE WEIGHT & ADD STRENGTH
- ★SEAT BOTTOM CONTOURED IN REAR FOR MULTI-ANGLED SEAT POSITION MOUNTING
- ★PRE-CUT SEAT BELT SLOTS
- ★CLIP-ON (OR HOOK-ON), HIGH-DENSITY FOAM, CLOTH COVERS
- ★SEATS & COVERS ARE SOLD SEPARATELY



## ECONOMY FULL CONTAINMENT SEATS

- ★BUILT FOR LOW HORSEPOWER SHORT TRACK APPLICATIONS
- ★AVAILABLE IN BOTH STANDARD & ROAD RACE VERSIONS
- ★20° LAYBACK WITH DUAL RIB SUPPORTS & WITH BUILT-IN HEAD & SHOULDER RESTRAINTS
- ★DESIGNED TO ACCOMMODATE ALL HEAD & NECK RESTRAINTS
- ★MIG-WELDED, .125" THICK 5052 ALUMINUM
- ★SEATS & COVERS ARE SOLD SEPARATELY



THE TERM "UPRIGHT" IS AN INDUSTRY TERM FOR SEATS THAT ARE ACTUALLY 10° LAYBACK

LIGHTWEIGHT SEATS ONLY	PART #
14" WIDE 20° LAYBACK SEAT	KIR 58100LW
14 1/2" WIDE 20° LAYBACK SEAT	KIR 58200LW
15" WIDE 20° LAYBACK SEAT	KIR 58300LW
15 1/2" WIDE 20° LAYBACK SEAT	KIR 58400LW
16" WIDE 20° LAYBACK SEAT	KIR 58500LW
17" WIDE 20° LAYBACK SEAT	KIR 58700LW
13" WIDE 10° UPRIGHT SEAT	KIR 56013LW
13 1/2" WIDE 10° UPRIGHT SEAT	KIR 56135LW
14" WIDE 10° UPRIGHT SEAT	KIR 56100LW
14 1/2" WIDE 10° UPRIGHT SEAT	KIR 56200LW
15" WIDE 10° UPRIGHT SEAT	KIR 56300LW
15 1/2" WIDE 10° UPRIGHT SEAT	KIR 56400LW
16" WIDE 10° UPRIGHT SEAT	KIR 56500LW
17" WIDE 10° UPRIGHT SEAT	KIR 56700LW

WIDTH	COVERS ONLY FOR BOTH LAYBACK & UPRIGHT			
	BLACK	BLUE	RED	GRAY
13"-14"	58111LW	58119LW	58112LW	58117LW
14.5"-15.5"	58311LW	58319LW	58312LW	58317LW
16"-17"	58511LW	58519LW	58512LW	58517LW

\*ADD "KIR" TO THE FRONT OF ALL COVER PART NUMBERS

ECONOMY 20° FULL CONTAINMENT SEATS	SEAT#	BLACK COVER#
CIRCLE TRACK F.C. SEAT, 13"	70130	7013011
CIRCLE TRACK F.C. SEAT, 14"	70140	7014011
CIRCLE TRACK F.C. SEAT, 15"	70150	7015011
CIRCLE TRACK F.C. SEAT, 16"	70160	7016011
CIRCLE TRACK F.C. SEAT, 17"	70170	7017011
ROAD RACE F.C. SEAT, 14"	71100	71111
ROAD RACE F.C. SEAT, 15"	71300	71311
ROAD RACE F.C. SEAT, 16"	71500	71511
ROAD RACE F.C. SEAT, 17"	71700	71711

## KIRKEY ADD-ON HEAD & SHOULDER RESTRAINT KITS

- ★THESE RESTRAINT KITS ALLOW YOU TO RETRO-FIT YOUR EXISTING SEAT TO TAKE ADVANTAGE OF THE ADDED SAFETY THAT A HEAD & SHOULDER SYSTEM PROVIDES
- ★.100" THICK, 5052 ALUMINUM
- ★EACH KIT IS SOLD COMPLETE & INCLUDES
  - \*ONE-PIECE HEAD RESTRAINT WITH A SHORT LEFT SIDE THAT ALLOWS EASY ENTRY INTO THE COCKPIT,
  - \*LEFT & RIGHT SHOULDER RESTRAINTS,
  - \*HARDWARE,
  - \*COVERS



ORIGINAL HEAD & SHOULDER RESTRAINT KIT WITH SHORT LEFT SIDE & WITH COVERS:			
BLACK	BLUE	RED	GRAY
KIR 98711-S	KIR 98719-S	KIR 98712-S	KIR 98717-S
TUBULAR HEAD & SHOULDER RESTRAINT KIT WITH SHORT LEFT SIDE & WITH COVER:			
BLACK	BLUE	RED	GRAY
KIR 98811	KIR 98819	KIR 98812	KIR 98817

## ADD-ON INDIVIDUAL HEAD RESTS & SHOULDER SUPPORTS

- ★LIGHTWEIGHT .125" THICK ALUMINUM; BOLT-ON DESIGN FITS ALMOST ALL SEATS; PADDED FOR COMFORT & SAFETY
- ★SOLD WITH MOUNTING HARDWARE & CLOTH COVERS ARE SOLD SEPARATELY



ADD-ON RESTS & SUPPORTS ONLY	PART #
LEFT SIDE HEAD REST	KIR 00200
RIGHT SIDE HEAD REST	KIR 00100
LEFT SIDE SHOULDER SUPPORT	KIR 00600
RIGHT SIDE SHOULDER SUPPORT	KIR 00500

HEAD REST COVERS ONLY				
SIDE	BLACK	BLUE	RED	GRAY
LEFT	KIR 00211	KIR 00219	KIR 00212	KIR 00217
RIGHT	KIR 00111	KIR 00119	KIR 00112	KIR 00117

SHOULDER SUPPORT COVERS ONLY				
SIDE	BLACK	BLUE	RED	GRAY
LEFT	KIR 00611	KIR 00619	KIR 00612	KIR 00617
RIGHT	KIR 00511	KIR 00519	KIR 00512	KIR 00517

HOW TO MEASURE FOR A SEAT: IN THE SEATED POSITION, USING 2 STRAIGHT EDGES, MEASURE ACROSS THE HIPS AT THE WIDEST POINT. THIS MEASUREMENT IS THE WIDTH OF SEAT THAT YOU NEED.

Place your order at (479) 646-6988, Fax to (479) 646-5939, or visit [www.southwestspeed.com](http://www.southwestspeed.com)



# KIRKEY FULL CONTAINMENT RACING SEATS

- ★WE CARRY SEVERAL STYLES OF KIRKEY FULL CONTAINMENT SEATS
- ★ALL STYLES ARE DESIGNED TO ACCOMMODATE HEAD & NECK RESTRAINT SYSTEMS
- ★THE OPTIONS, STYLES, & SIZES ARE TOO NUMEROUS TO LIST IN THIS CATALOG; PLEASE GIVE US A CALL TO DISCUSS WHICH SEAT & CHARACTERISTICS ARE BEST FOR YOU
- ★FOUR OF THE POPULAR SERIES OF FULL CONTAINMENT SEATS ARE SHOWN BELOW



KIR 68000

## NEW KIRKEY 68 & 69 SERIES FULL CONTAINMENT SEATS

- ★THESE ARE PROBABLY THE BEST VALUE IN FULL CONTAINMENT SEAT AVAILABLES
- ★18° LAYBACK (68000) & 10° LAYBACK (69000) SEATS HAVE A UNIQUE DESIGN TO ADD STRENGTH, WHILE STILL KEEPING THE WEIGHT DOWN
- ★ALUMINUM EXTRUSION OFFSET ON PERIMETER OF THE SEAT ADDS THE STRENGTH & KEEPS THE INSIDE OF THE SEAT SMOOTH
- ★FEATURES BUILT-IN REINFORCED PADDED SHOULDER RESTRAINTS, A REINFORCED VERTICALLY-ADJUSTABLE PADDED HEAD RESTRAINT, PADDED RIB PROTECTORS, AND A CONTOURED ELONGATED BOTTOM WITH EXTENDED LEG SUPPORTS & CENTER LEG SEPARATOR
- ★THE HEAD RESTRAINT IS DESIGNED FOR EASY ENTRY & EXIT
- ★FEATURES A EASY-TO-INSTALL CLOTH COVER
- ★AVAILABLE 14" TO 18" WIDE

## KIRKEY 53 SERIES DELUXE FULL CONTAINMENT SEAT

- ★15° LAYBACK 3 PIECE SEAT IS 100% CUSTOMIZABLE TO FIT ANY DRIVER
- ★THE BASE OF THE SEAT IS AVAILABLE 14" TO 18" WIDE IN SHORT, STANDARD, & TALL VERSIONS
- ★1 PIECE SHOULDER UNIT IS AVAILABLE 18" TO 23" WIDE
- ★THERE ARE 4 OPTIONS FOR THE HEAD UNIT:  
STANDARD HEAD, STANDARD HEAD WITH SHORT LEFT SIDE, TUBULAR HEAD, & TUBULAR HEAD WITH SHORT LEFT SIDE
- ★FEATURES A FULL AIR KNIT COVER FOR COMPLETE COMFORT
- ★OPTIONAL LEG EXTENSIONS (#KIR 01300 & #KIR 01400) ARE ALSO AVAILABLE ON PAGE 193

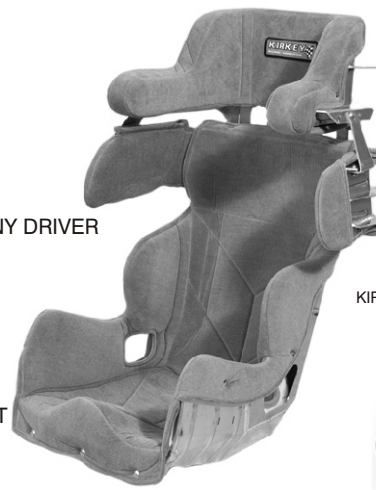

SHOWN WITH THE STANDARD HEAD WITH THE SHORT LEFT SIDE



KIR 53000

SHOWN WITH THE TUBULAR HEAD WITH THE SHORT LEFT SIDE



KIR 63000

## KIRKEY 63 SERIES FULL CONTAINMENT REINFORCED ADJUSTABLE SEAT

- ★20° LAYBACK SEAT IS REINFORCED IN THE REAR WITH EXTRA SQUARE TUBING COMPONENTS TO GIVE THE UTMOST STRENGTH
- ★MODULAR DESIGN FEATURES A BASE WITH SLOTTED HOLES TO ATTACH EACH INDIVIDUAL SHOULDER RESTRAINT, WHICH CAN BE ADJUSTED FOR COMFORT
- ★THE TUBULAR HEAD RESTRAINT IS THEN BOLTED TO THE BASE & THE SHOULDERS
- ★THE BASE IS AVAILABLE 14" TO 18" WIDE
- ★FEATURES AN AIR KNIT COVER THAT COVERS EVERYTHING BUT THE TUBULAR HEAD

## KIRKEY 66 SERIES LIGHTWEIGHT ADJUSTABLE OPEN WHEEL FULL CONTAINMENT SEAT

- ★10° LAYBACK SEAT FEATURES STRATEGICALLY PLACED FLARED OPENINGS TO SAVE WEIGHT & ADD STRENGTH
- ★MODULAR DESIGN FEATURES A BASE WITH SLOTTED HOLES TO ATTACH EACH INDIVIDUAL SHOULDER RESTRAINT, WHICH CAN BE ADJUSTED FOR COMFORT
- ★THE TUBULAR HEAD RESTRAINT IS THEN BOLTED TO THE BASE & THE SHOULDERS
- ★BASE IS AVAILABLE 14" TO 17" WIDE IN SHORT, STANDARD, & TALL VERSIONS
- ★FEATURES A CLOTH COVER THAT COVERS EVERYTHING BUT THE TUBULAR HEAD & THE LEG RESTS



KIR 66000

Place your order at (479) 646-6988, Fax to (479) 646-5939, or visit [www.southwestspeed.com](http://www.southwestspeed.com)



# KIRKEY SEAT ACCESSORIES

## ADD-ON DELUXE LEG RESTS

- ★LIGHTWEIGHT .125" THICK ALUMINUM
- ★BOLT-ON DESIGN WILL FIT ALMOST ALL SEATS
- ★PADDED FOR COMFORT & SAFETY
- ★RESTS & CLOTH COVERS ARE SOLD SEPARATELY

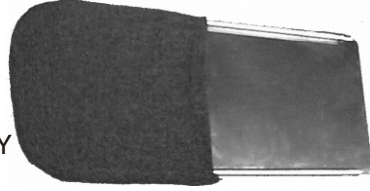

ADD-ON DELUXE LEG RESTS ONLY					PART #
LEFT SIDE DELUXE LEG REST ONLY				KIR 00400	
RIGHT SIDE DELUXE LEG REST ONLY				KIR 00300	
COVERS ONLY					
SIDE	BLACK	BLUE	RED	GRAY	
LEFT	KIR 00411	KIR 00419	KIR 00412	KIR 00417	
RIGHT	KIR 00311	KIR 00319	KIR 00312	KIR 00317	

## ADD-ON LIGHTWEIGHT LEG RESTS

- ★LIGHTWEIGHT .125" THICK ALUMINUM
- ★FEATURES DRILLED, FLARED OPENINGS TO SAVE WEIGHT & ADD STRENGTH
- ★BOLT-ON DESIGN WILL FIT ALMOST ALL SEATS
- ★RESTS & CLOTH COVERS ARE SOLD SEPARATELY



ADD-ON L.W. LEG RESTS ONLY					PART #
LEFT SIDE L.W. LEG REST ONLY				KIR 00400LW	
RIGHT SIDE L.W. LEG REST ONLY				KIR 00300LW	
COVERS ONLY					
SIDE	BLACK	BLUE	RED	GRAY	
LEFT	00411LW	00419LW	00412LW	00417LW	
RIGHT	00311LW	00319LW	00312LW	00317LW	

\*ADD "KIR" TO THE FRONT OF ALL COVER PART NUMBERS

## ADD-ON FULL CONTAINMENT SEAT LEG EXTENSIONS

- ★EXTRA STRONG LEG EXTENSIONS BOLT TO THE KIRKEY FULL CONTAINMENT SEATS
- ★DELUXE EXTENSIONS MEASURE 20" IN TOTAL LENGTH & 10" IN TOTAL HEIGHT
- ★PADDED FOR COMFORT & SAFETY
- ★EXTENSIONS & CLOTH COVERS ARE SOLD SEPARATELY



FULL CONTAIN. LEG EXTENSIONS ONLY					PART #
LEFT SIDE F.C. LEG EXTENSION ONLY				KIR 01400	
RIGHT SIDE F.C. LEG EXTENSION ONLY				KIR 01300	
COVERS ONLY					
SIDE	BLACK	BLUE	RED	GRAY	
LEFT	KIR 01411	KIR 01419	KIR 01412	KIR 01417	
RIGHT	KIR 01311	KIR 01319	KIR 01312	KIR 01317	

# KIRKEY SEAT ACCESSORIES

## SPRINT/MIDGET LEG PROTECTORS

- ★LIGHTWEIGHT ALUMINUM FORMED TO SURROUND CENTER STEERING UNIT
- ★FIRE RESISTANT FOAM ELIMINATES BULKY COVER
- ★BEAD ROLLED FOR EXTRA STRENGTH



DESCRIPTION	PART #
LEG PROTECTOR, SPRINT	KIR 99500
LEG PROTECTOR, MIDGET	KIR 99502

## LUMBAR SUPPORT

- ★SUPPORTS LOWER BACK & RELIEVES BACK STRESS
- ★COMES COMPLETE WITH RIVETS & SNAPS TO FIT ANY SEAT



PART #KIR 99020

# HELMET RESTRAINTS

- ★PREVENTS G-FORCES FROM PULLING HEAD DURING CORNERING
- ★PREVENTS FATIGUE
- ★LOOPS UNDER ARM
- ★INCLUDES HOOK & POP RIVET TO ATTACH TO HELMET



DESCRIPTION	PART #
HELMET RESTRAINT, BLACK	800-112
HELMET RESTRAINT, BLUE	800-113
HELMET RESTRAINT, RED	800-114

# ARM RESTRAINTS

- ★PREVENTS ARM INJURY
- ★LATCHES TO SEAT BELT BUCKLE
- ★SOLD IN PAIRS



DESCRIPTION	PART #
ARM RESTRAINTS, WHITE (PAIR)	790-950
ARM RESTRAINTS, BLACK (PAIR)	790-952
ARM RESTRAINTS, BLUE (PAIR)	790-953
ARM RESTRAINTS, RED (PAIR)	790-954
ARM RESTRAINTS, YELLOW (PAIR)	790-955
ARM RESTRAINTS, ORANGE (PAIR)	790-956
ARM RESTRAINTS, GREEN (PAIR)	790-957
ARM RESTRAINTS, PURPLE (PAIR)	790-958
ARM RESTRAINTS, SILVER (PAIR)	790-960

Place your order at (479) 646-6988, Fax to (479) 646-5939, or visit [www.southwestspeed.com](http://www.southwestspeed.com)

# SEAT BELTS SHORT "Y" TYPE

## ★5 POINT SAFETY HARNESS

ASSEMBLY INCLUDES:

- \*3" WIDE, SHORT "Y" SHOULDER HARNESS,
- \*3" WIDE, BOLT-IN LAP BELT,
- \*2" WIDE SUB BELT (CROTCH STRAP) THAT CAN BE BOLTED OR WRAPPED AROUND THE CHASSIS, &
- \*ALL NECESSARY BRACKETS

## ★SHORT "Y" TYPE SHOULDER HARNESS BOLTS TO THE CHASSIS BEHIND THE SEAT JUST BELOW THE SHOULDERS



DESCRIPTION	COLOR	PART #
SHORT "Y" ASSY.	BLACK	RJS 505021606
SHORT "Y" ASSY.	BLUE	RJS 505021606-3
SHORT "Y" ASSY.	RED	RJS 505021606-4
SHORT "Y" ASSY.	ORANGE	RJS 505021606-5
SHORT "Y" ASSY.	YELLOW	RJS 505021606-6
SHORT "Y" ASSY.	GRAY	RJS 505021606-7
SHORT "Y" ASSY.	PURPLE	RJS 505021606-8
SHORT "Y" ASSY.	GREEN	RJS 505021606-9

# INDIVIDUAL TYPE

## ★5 POINT SAFETY HARNESS

ASSEMBLY INCLUDES:

- \*TWO 3" WIDE, INDIVIDUAL SHOULDER HARNESSES,
- \*3" WIDE, BOLT-IN LAP BELT,
- \*2" WIDE SUB BELT (CROTCH STRAP) THAT CAN BE BOLTED OR WRAPPED AROUND THE CHASSIS, &
- \*ALL NECESSARY BRACKETS

## ★INDIVIDUAL TYPE SHOULDER HARNESSES BOLT TO THE CHASSIS BEHIND THE BASE OF THE SEAT



DESCRIPTION	COLOR	PART #
INDIVIDUAL ASSY.	BLACK	RJS 505021806
INDIVIDUAL ASSY.	BLUE	RJS 505021806-3
INDIVIDUAL ASSY.	RED	RJS 505021806-4
INDIVIDUAL ASSY.	ORANGE	RJS 505021806-5
INDIVIDUAL ASSY.	YELLOW	RJS 505021806-6
INDIVIDUAL ASSY.	GRAY	RJS 505021806-7
INDIVIDUAL ASSY.	PURPLE	RJS 505021806-8
INDIVIDUAL ASSY.	GREEN	RJS 505021806-9

# HARNESS PADS

- ★NOMEX HARNESS PADS FIT 2" & 3" WIDE BELTS & HELP PROTECT DRIVER FROM BRUISING DURING SUDDEN & VIOLENT STOPS; SOLD IN PAIRS



DESCRIPTION	PART #
3" NOMEX HARNESS PADS, BLACK	790-962
3" NOMEX HARNESS PADS, BLUE	790-963
3" NOMEX HARNESS PADS, RED	790-964

# SEAT BELTS WRAP AROUND TYPE

## ★5 POINT SAFETY HARNESS

ASSEMBLY INCLUDES:

- \*3" WIDE SHOULDER HARNESS,
- \*3" WIDE LAP BELT, WHICH CAN BE BOLTED TO OR WRAPPED AROUND THE CHASSIS,
- \*2" WIDE SUB BELT (CROTCH STRAP), WHICH CAN BE BOLTED TO OR WRAPPED AROUND THE CHASSIS, &
- \*ALL NECESSARY BRACKETS

## ★2 STYLES AVAILABLE: DUAL STYLE HAS 2 SHOULDER HARNESSES THAT INDIVIDUALLY WRAP AROUND THE CHASSIS BEHIND THE SEAT, WHILE THE SINGLE STYLE HAS 1 LONG HARNESS THAT WRAPS AROUND AT ONE SPOT BEHIND THE SEAT & COVER BOTH SHOULDERS

## ★WRAP AROUND BELTS ARE COMMONLY USED IN SPRINT CARS, MIDGETS, & OTHER OPEN WHEEL



DESCRIPTION	COLOR	DUAL #	SINGLE #
WRAP AROUND	BLACK	RJS 5021906	RJS 5022
WRAP AROUND	BLUE	RJS 5021906-3	RJS 5023
WRAP AROUND	RED	RJS 5021906-4	RJS 5024
WRAP AROUND	ORANGE	RJS 5021906-5	RJS 5025
WRAP AROUND	YELLOW	RJS 5021906-6	RJS 5026
WRAP AROUND	GRAY	RJS 5021906-7	RJS 5027
WRAP AROUND	PURPLE	RJS 5021906-8	RJS 5028
WRAP AROUND	GREEN	RJS 5021906-9	RJS 5029

# BUGGY BELTS

## ★BUGGY SAFETY HARNESS

ASSEMBLY INCLUDES:

- \*2" WIDE, "Y" TYPE, BOLT-IN SHOULDER HARNESS,
- \*2" WIDE, BOLT-IN LAP BELT, &
- \*ALL NECESSARY BRACKETS

## ★THE SHOULDER HARNESS & LAP BELT ARE SEWN TOGETHER

## ★THESE ARE NOT COMPETITION OR HIGH PERFORMANCE BELTS



DESCRIPTION	COLOR	PART #
BUGGY BELT	BLACK	RJS 50520
BUGGY BELT	BLUE	RJS 50520-3
BUGGY BELT	RED	RJS 50520-4

# SEAT BELT HARDWARE

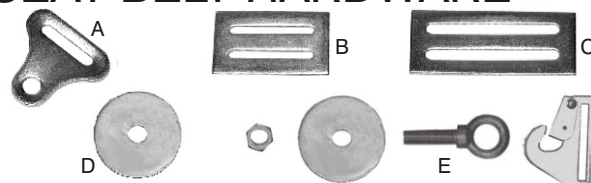

DESCRIPTION	PART #
2" OR 3" BELT ANCHOR BRACKET (A)	RJS 101
2" BELT SLIDE BAR (B)	RJS 105
3" BELT SLIDE BAR (C)	RJS 102
HEAVY DUTY EYE BOLT WASHER (D)	RJS 104
FLOOR MOUNT SNAP-IN KIT (E)	RJS 30309

Place your order at (479) 646-6988, Fax to (479) 646-5939, or visit [www.southwestspeed.com](http://www.southwestspeed.com)

# NECK BRACES

- ★NOMEX NECK BRACES (OR HELMET SUPPORTS)
- ★BOTH HORSESHOE & 360° TYPE AVAILABLE
- ★VELCRO CLOSURES
- ★RJS NECK BRACES ARE SFI CERTIFIED 3.3



DESCRIPTION	PART #
HORSESHOE NECK BRACE, BLACK	RJS 20216
HORSESHOE NECK BRACE, BLUE	RJS 20216-3
HORSESHOE NECK BRACE, RED	RJS 20216-4
360° NECK BRACE, BLACK	RJS 202161
360° NECK BRACE, BLUE	RJS 202161-3
360° NECK BRACE, RED	RJS 202161-4

# NOMEX UNDERWEAR

- ★SFI CERTIFIED 3.3
- ★FLAME RETARDANT KNIT NOMEX UNDERWEAR
- ★GIVES MULTI-LAYER PROTECTION WHEN USED WITH A FIRE SUIT
- ★LONG JOHN STYLE WITH LONG SLEEVES
- ★NATURAL COLOR
- ★SOLD IN SETS & INDIVIDUALLY



2 PIECE NOMEX UNDERWEAR			
SIZE	TOP	BOTTOM	COMPLETE
S	RJS 20203-1S	RJS 20203-2S	RJS 20203-S
M	RJS 20203-1M	RJS 20203-2M	RJS 20203-M
L	RJS 20203-1L	RJS 20203-2L	RJS 20203-L
XL	RJS 20203-1XL	RJS 20203-2XL	RJS 20203-XL
XXL	RJS 20203-1XXL	RJS 20203-2XXL	RJS 20203-XXL

# NOMEX HEAD SOCKS

- ★SFI CERTIFIED 3.3
- ★SINGLE LAYER, FLAME RETARDANT NOMEX
- ★GIVES MULTI-LAYER PROTECTION WHEN USED WITH A NOMEX LINED HELMET
- ★NATURAL COLOR
- ★3 DIFFERENT STYLES AVAILABLE



DESCRIPTION	PART #
SINGLE EYE OPENING HEAD SOCK	RJS 20205-1
DUAL EYE OPENING HEAD SOCK	RJS 20206-1
FULL FACE OPENING HEAD SOCK	RJS 20215-1

# RJS DRIVING UNIFORMS

- ★SFI CERTIFIED 3-2A/1
- ★RJS SINGLE LAYER PROBAN DRIVING SUITS ARE CONSTRUCTED WITH PROBAN/FR-7A MATERIAL & SEWN WITH HIGH-QUALITY NOMEX THREAD, CUFFS, & ZIPPERS
- ★SUITS FEATURE A VERTICAL STRIPE DOWN EACH SIDE, THREE HORIZONTAL RINGS ON EACH BICEP, & WHITE TRIM THROUGHOUT
- ★1 & 2 PIECE AVAILABLE; 2 PIECE CAN BE SOLD BY THE PIECE OR COMPLETE



SIZING CHART*				
SIZE	CHEST	WAIST	HIPS	INSEAM
SMALL	38"-40"	30"-34"	36"-38"	30"
MEDIUM	40"-42"	34"-36"	38"-40"	30"
LARGE	42"-44"	36"-38"	40"-42"	30"
X-LARGE	44"-46"	38"-42"	44"-46"	30"
XX-LARGE	46"-48"	42"-44"	46"-48"	30"

\*DON'T USE STANDARD JEAN SIZES BECAUSE SUITS FIT DIFFERENTLY

1 PIECE PROBAN UNIFORMS			
SIZE	BLACK	BLUE	RED
S	RJS 1004-12	RJS 1004-13	RJS 1004-14
M	RJS 1004-22	RJS 1004-23	RJS 1004-24
L	RJS 1004-32	RJS 1004-33	RJS 1004-34
XL	RJS 1004-42	RJS 1004-43	RJS 1004-44

BLACK 2 PIECE PROBAN UNIFORMS			
SIZE	JACKET	PANTS	COMPLETE
S	RJS 1004-112	RJS 1004-212	RJS 1004SEP12
M	RJS 1004-122	RJS 1004-222	RJS 1004SEP22
L	RJS 1004-132	RJS 1004-232	RJS 1004SEP32
XL	RJS 1004-142	RJS 1004-242	RJS 1004SEP42
XXL	RJS 1004-152	RJS 1004-252	RJS 1004SEP52

BLUE 2 PIECE PROBAN UNIFORMS			
SIZE	JACKET	PANTS	COMPLETE
S	RJS 1004-113	RJS 1004-213	RJS 1004SEP13
M	RJS 1004-123	RJS 1004-223	RJS 1004SEP23
L	RJS 1004-133	RJS 1004-233	RJS 1004SEP33
XL	RJS 1004-143	RJS 1004-243	RJS 1004SEP43
XXL	RJS 1004-153	RJS 1004-253	RJS 1004SEP53

RED 2 PIECE PROBAN UNIFORMS			
SIZE	JACKET	PANTS	COMPLETE
S	RJS 1004-114	RJS 1004-214	RJS 1004SEP14
M	RJS 1004-124	RJS 1004-224	RJS 1004SEP24
L	RJS 1004-134	RJS 1004-234	RJS 1004SEP34
XL	RJS 1004-144	RJS 1004-244	RJS 1004SEP44
XXL	RJS 1004-154	RJS 1004-254	RJS 1004SEP54

# NOMEX SOCKS

- ★FLAME RETARDANT KNIT NOMEX MATERIAL IS COMFORTABLE & DURABLE; PROVIDING EXTRA PROTECTION FOR FEET & ANKLES
- ★SFI CERTIFIED 3.3
- ★NATURAL COLOR

DESCRIPTION	PART #
SMALL (5 - 8)	RJS 20204-S
MEDIUM (8 - 9 1/2)	RJS 20204-M
LARGE (9 1/2 - 12)	RJS 20204-L
X-LARGE (12 - 14)	RJS 20204-XL

CORRESPONDING SHOE SIZE SHOWN IN ( )



Place your order at (479) 646-6988, Fax to (479) 646-5939, or visit [www.southwestspeed.com](http://www.southwestspeed.com)



# RJS DRIVING BOOTS HIGH TOP

- ★SFI CERTIFIED 3.3/5
- ★DURABLE, COMFORTABLE, & SNUG FITTING



- ★CONSTRUCTED WITH BRUSHED LEATHER & ARIMAND KEVLAR LINER FOR EXTRA COMFORT
- ★FEATURES A HIGH-QUALITY RUBBER SOLE & AN EASY-TO-OPEN VELCRO TOP

SIZE	BLACK	BLUE	RED
5	RJS 20209105	RJS 202091305	RJS 202091405
6	RJS 20209106	RJS 202091306	RJS 202091406
7	RJS 20209107	RJS 202091307	RJS 202091407
8	RJS 20209108	RJS 202091308	RJS 202091408
9	RJS 20209109	RJS 202091309	RJS 202091409
10	RJS 20209110	RJS 202091310	RJS 202091410
11	RJS 20209111	RJS 202091311	RJS 202091411
12	RJS 20209112	RJS 202091312	RJS 202091412
13	RJS 20209113	RJS 202091313	RJS 202091413
14	RJS 20209114	RJS 202091314	RJS 202091414

# RJS DRIVING GLOVES

- ★RJS SINGLE LAYER NOMEX DRIVING GLOVES
- ★SFI CERTIFIED 3.3/1
- ★TIGHT FITTING
- ★LONG GAUNTLET STYLE



SIZE	BLACK	BLUE	RED
S	RJS 20213-S	RJS 20213-3S	RJS 20213-4S
M	RJS 20213-M	RJS 20213-3M	RJS 20213-4M
L	RJS 20213-L	RJS 20213-3L	RJS 20213-4L
XL	RJS 20213-XL	RJS 20213-3XL	RJS 20213-4XL

### GLOVE SIZING INFORMATION

TO FIND GLOVE SIZE IN INCHES, MEASURE AROUND THE LARGEST PART OF THE HAND OVER KNUCKLES WHILE MAKING A FIST, EXCLUDING THUMB.

7" TO 8 1/2" : SMALL      8" TO 9 1/2" : MEDIUM  
9" TO 10 1/2" : LARGE      10" TO 11 1/2" : X-LARGE

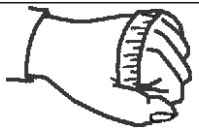

# WINDOW MOUNTED DUCTS SINGLE HOLE

- ★HIGH QUALITY CLEAR PLASTIC
- ★FITS 3" BRAKE HOSE
- ★EASY INSTALLATION

PART #210-019



# DUAL HOLE

- ★HIGH QUALITY CLEAR PLASTIC
- ★FITS 3" BRAKE HOSE
- ★EASY INSTALLATION

PART #210-023



# FRESH AIR SYSTEMS COMPLETE FRESH AIR UNITS

- ★PROVIDES FRESH, CLEAN AIR TO THE DRIVER
- ★12 VOLT UNITS GIVE LOW AMP DRAIN
- ★FILTER IS EASILY REPLACEABLE
- ★INSIDE AIR UNIT IS DESIGNED FOR RACING WITHOUT WINDOWS WHERE THE FILTER CAN PICK UP AIR WITHOUT DUCTING AIR TO IT
- ★OUTSIDE AIR UNIT IS DESIGNED FOR RACING WITH WINDOWS WHERE AIR HAS TO BE DUCTED FROM THE OUTSIDE OF THE CAR; THE COVER ON IT HAS A 3" HOSE OPENING FOR DUCTING THE AIR TO IT



#801-001  
INSIDE AIR  
UNIT SHOWN  
WITH HOSE  
(NOT INCLUDED)

#801-011  
OUTSIDE AIR  
UNIT SHOWN

DESCRIPTION	PART #
FRESH AIR BLOWER, INSIDE UNIT	801-001
FRESH AIR BLOWER, OUTSIDE UNIT	801-011
CLEAR HOSE WITH ENDS, 4' LONG	801-004
REPLACEMENT MOTOR ONLY	801-013
REPLACEMENT SQUIRREL CAGE ONLY	801-023
REPLACEMENT ALUM. FILTER COVER	801-024
REPLACEMENT FILTER ELEMENT	801-049

# HELMET MOUNTED UNIT

- ★SELF-CONTAINED UNIT MOUNTS DIRECTLY TO THE HELMET
- ★USES 12 VOLT POWER
- ★WASHABLE & REUSABLE FILTER
- ★FEATURES QUICK DISCONNECT FOR EASY EXIT OUT OF CAR
- ★LOW PROFILE PREVENTS SNAGGING

PART  
#801-021



# COOLING DUCT HOSE

- ★3" ID", BLACK IN COLOR
- ★VERY FLEXIBLE
- ★SAFE UP TO 300°
- ★SOLD IN 10' LENGTHS

PART #210-003



NOTE: FOR A CONSTANT STREAM OF NEW PRODUCTS & UP-TO-THE-SECOND PRICING, VISIT [WWW.SOUTHWESTSPEED.COM](http://WWW.SOUTHWESTSPEED.COM)

Place your order at (479) 646-6988, Fax to (479) 646-5939, or visit [www.southwestspeed.com](http://www.southwestspeed.com)

# RACING OPTICS LAMINATED TEAROFFS

- ★ RACING OPTICS TEAROFFS ARE THE CLEAREST, MOST SUPERIOR TEAROFFS ON THE MARKET
- ★ STACKABLE UP TO 35 TEAROFFS; EVEN WITH 35 TEAROFFS ON THE SHIELD, YOU CAN STILL CLEARLY SEE THROUGH THEM
- ★ AVAILABLE IN CLEAR, AMBER, & SMOKE
- ★ AMBER IS CONSIDERED BY SOME TO BE AN ADVANTAGE IN NIGHT RACES, WHILE SMOKE CAN BE AN ADVANTAGE IN DAY RACES
- ★ RACING OPTICS ARE PRICED & SOLD IN INDIVIDUAL "SLEEVES"
- ★ EACH SLEEVE CONTAINS 4 STACKS WITH 7 TEAROFFS IN EACH STACK, SO 28 TEAROFFS IN EACH SLEEVE

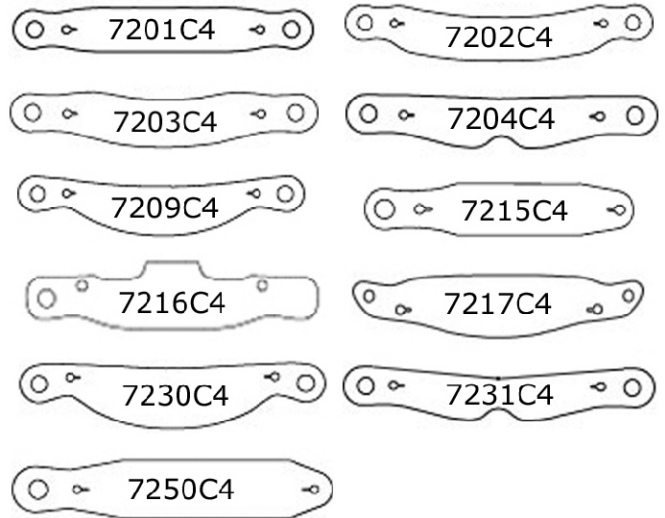

RACING OPTICS TEAROFFS FITS	STYLE	BUTTON CENTERS	CLEAR PART #	AMBER PART #	SMOKE PART #
SIMPSON VOYAGER, HJC, & SHOEI BIKE	STRAIGHT	11 1/2"	ROI 7201C4	ROI 7201A4	ROI 7201S4
BELL (EXCEPT X-15), G-FORCE, PYROTECH	BANANA	12 3/8"	ROI 7202C4	ROI 7202A4	ROI 7202S4
SIMPSON MATRIX, SX, JR. SHARK, VOYAGER, & SHOEI CAR	BANANA	11 1/2"	ROI 7203C4	ROI 7203A4	ROI 7203S4
SIMPSON RX, SUPER BANDIT, & DIAMONDBACK	NOSE-NOTCHED	11 1/2"	ROI 7204C4	ROI 7204A4	ROI 7204S4
SIMPSON SHARK, SUPER SHARK, VUDO, INVADER, VALOR, IMPACT AIR DRAFT, & SUPER SPORT	BANANA	12 3/4"	ROI 7209C4	ROI 7209A4	ROI 7209S4
ALL BIEFFE HELMETS	STRAIGHT	10 3/8"	ROI 7215C4	ROI 7215A4	ROI 7215S4
ALL ARAI HELMETS WITH CUT-OUTS	VENT CUT-OUTS	11 1/2"	ROI 7216C4	ROI 7216A4	ROI 7216S4
ARAI GP	NO VENT CUT-OUTS	11 1/2"	ROI 7217C4	ROI 7217A4	ROI 7217S4
IMPACT VAPOR, CHARGER, & DRAFT	BANANA	12"	ROI 7230C4	ROI 7230A4	ROI 7230S4
IMPACT CHAMP & NITRO	NOSE-NOTCHED	11 1/2"	ROI 7231C4	ROI 7231A4	ROI 7231S4
ALL SPARCO HELMETS	STRAIGHT	11 7/8"	ROI 7250C4	ROI 7250A4	ROI 7250S4

# ORIGINAL ECONOMY TEAROFFS

- ★ 2 MIL THICK, CLEAR RACING TEAROFFS ARE PRICED & SOLD IN BOXES
- ★ EACH BOX CONTAINS 200 TEAROFFS, PACKAGED 20 PER PACK IN 10 ZIP-LOCK BAGS

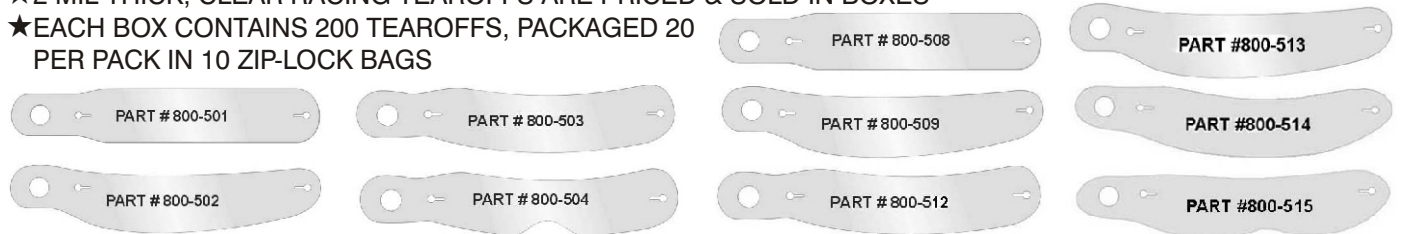

ORIGINAL ECONOMY TEAROFFS FITS	STYLE	BUTTON CENTERS	CLEAR PART #
SIMPSON, ARAI, & MOST OFF BRANDS	STRAIGHT	11 1/2"	800-501
BELL (EXCEPT X-15), G-FORCE, PYROTECH, RCI SA2000, & M2000	BANANA	12 3/8"	800-502
SIMPSON MATRIX, SX, JR. SHARK, VOYAGER, & SHOEI CAR	BANANA	11 1/2"	800-503
SIMPSON RX, BANDITS, & DIAMONDBACK	NOSE-NOTCHED	11 1/2"	800-504
SIMPSON OLDER BANDITS & SPARCO	STRAIGHT	12"	800-508
SIMPSON SHARK, INVADER, VALOR, & IMPACT AIR DRAFT	BANANA	12 3/4"	800-509
ALL BIEFFE HELMETS	BANANA	10 3/4"	800-512
SIMPSON SUPER SHARK & VUDO	BANANA	13"	800-513
IMPACT VAPOR, CHARGER, & DRAFT	BANANA	11 3/4"	800-514
IMPACT BIG CHAMP	NOSE-NOTCHED	11 3/4"	800-515

# TEAROFF BUTTONS

- ★ THESE REPLACEMENT TEAROFF BUTTONS ARE OFFSET & ADJUSTABLE
- ★ SOLD IN PAIRS



**PART #800-530**

Place your order at (479) 646-6988, Fax to (479) 646-5939, or visit [www.southwestspeed.com](http://www.southwestspeed.com)

# STEERING WHEELS



- ★LIGHTWEIGHT ALUMINUM WHEELS
- ★DISHED & FLAT, FOAM PADDED & UNCOATED AVAILABLE



FOAM PADDED	BLACK	BLUE	RED
13", 3 SPOKE, DISH, KART	150-292		
15", 3 SPOKE, DISHED	150-302	150-303	150-304
15", 4 SPOKE, DISHED	150-307	N/A	N/A
17", 3 SPOKE, DISHED	150-312	150-313	150-314

UNCOATED 3 SPOKE	SILVER	BLACK
14" DISHED, SMOOTH	LON 56834	
14" DISHED, DRILLED	LON 56835	LON 56833
15" DISHED, SMOOTH	LON 56836	
15" DISH SMOOTH W/BUMPS	LON 56822	
15" DISHED, DRILLED	LON 56837	LON 56838
15" FLAT, DRILLED, SPRINT	LON 56866	LON 56867

# STEERING HUB PADS

- ★INSTALLS EASILY ON STEERING WHEEL
- ★AVAILABLE FOR DISH & FLAT WHEELS
- ★REDUCES CHANCE OF INJURY

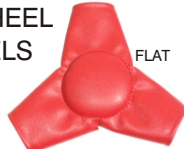

COLOR	DISH	FLAT
BLACK	150-362	150-372
BLUE	150-363	150-373
RED	150-364	150-374
YELLOW	N/A	150-375
ORANGE	150-366	N/A



# QUICK DISCONNECTS

## PULL, 360° RING TYPE

- ★SPLINED, 360 DEGREE, PULL TYPE
- ★LIGHTWEIGHT ALUMINUM HUB
- ★1 1/4"-20 SPLINED, STEEL MANDREL
- ★3/4" BORE

SPLINED MANDREL #150-352

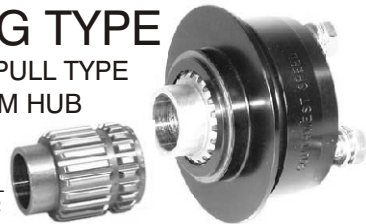

DESCRIPTION	PART #
360° RING TYPE ASSEMBLY	150-350
SPLINED MANDREL ONLY FOR #150-350	150-352

# PUSH BUTTON TYPE

- ★AVAILABLE W/ HEX OR SPLINED STEEL MANDRELS
- ★LIGHTWEIGHT ALUMINUM HUBS
- ★3/4" BORES

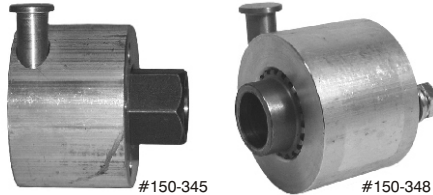

DESCRIPTION	PART #
PUSH BUTTON TYPE ASSEMBLY, HEX	150-345
PUSH BUTTON TYPE ASSEMBLY, SPLINED	150-348
MANDREL ONLY FOR #150-345, HEX	150-347
MANDREL ONLY FOR #150-348, SPLINED	150-349

# WINDOW NETS

- ★SOUTHWEST SPEED NETS FEATURE A RIGID TOP & BOTTOM SEWN ON BOTH SIDES W/ A TUNNEL IN THE MIDDLE TO PUT THE INSTALLATION KIT THROUGH; NO LOOSE LOOPS TO BUNCH UP
- ★BOTH THE RIBBON & MESH ARE BIG ENOUGH TO SEE THROUGH, YET THICK ENOUGH TO KEEP DEBRIS OUT

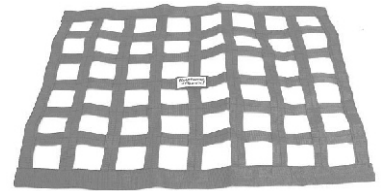

# RIBBON

- ★18" TALL RIBBON NETS IN WIDTHS OF 18", 22", & 24"

DESCRIPTION	18" x 18"	18" x 22"	18" x 24"
WHITE RIBBON	N/A	800-001	800-011
BLACK RIBBON	800-022	800-002	800-012
BLUE RIBBON	800-023	800-003	800-013
RED RIBBON	800-024	800-004	800-014
YELLOW RIBBON	800-025	800-005	800-015
ORANGE RIBBON	800-026	800-006	800-016
GREEN RIBBON	800-027	800-007	800-017
PURPLE RIBBON	800-028	800-008	800-018
PINK RIBBON	N/A	800-009	800-019

# MESH

- ★18" TALL MESH NETS IN WIDTHS OF 22" & 24"

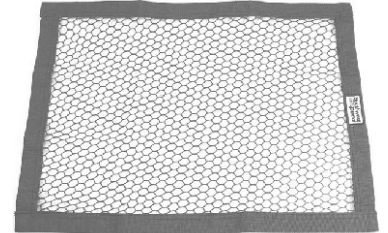

DESCRIPTION	18" x 22"	18" x 24"
WHITE MESH	800-051	800-061
BLACK MESH	800-052	800-062
BLUE MESH	800-053	800-063
RED MESH	800-054	800-064
YELLOW MESH	800-055	800-065
ORANGE MESH	800-056	800-066
GREEN MESH	800-057	800-067
PURPLE MESH	800-058	800-068

# WINDOW NET INSTALLATION KITS

- ★ALL INSTALLATION KITS FIT NETS UP TO 24" WIDE
- ★NECESSARY HARDWARE INCLUDED

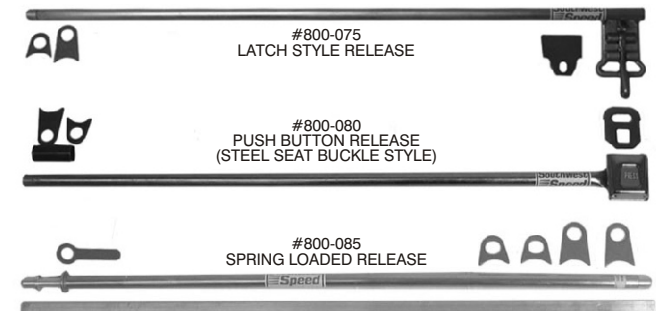

DESCRIPTION	PART #
LATCH STYLE RELEASE KIT	800-075
PUSH BUTTON RELEASE KIT	800-080
SPRING LOADED RELEASE KIT	800-085

Place your order at (479) 646-6988, Fax to (479) 646-5939, or visit [www.southwestspeed.com](http://www.southwestspeed.com)



# ROLL CAGE KITS

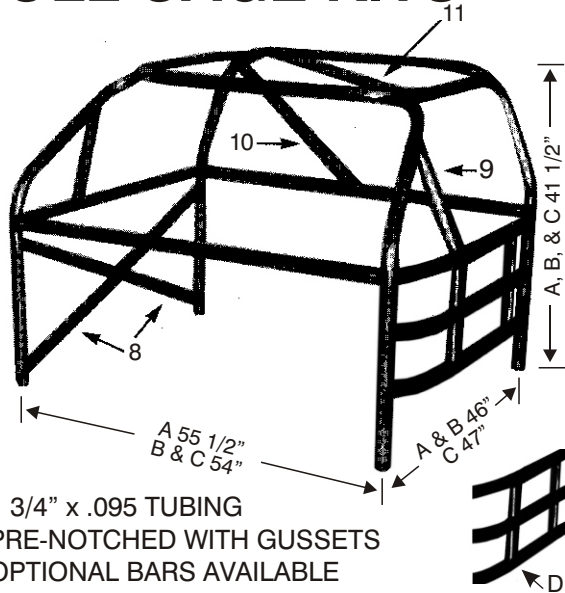

- ★1 3/4" x .095 TUBING
- ★PRE-NOTCHED WITH GUSSETS
- ★OPTIONAL BARS AVAILABLE

DESCRIPTION	PART #
ROLL CAGE KIT, PRE-1977 GM (A)	700-005
ROLL CAGE KIT, 1978-UP GM (B)	700-010
ROLL CAGE KIT, MUSTANG (C)	700-001
RIGHT SIDE DOOR BAR KIT ONLY (D)	700-038
OPTION KIT ONLY (8, 9, 10, & 11)	700-040

NOTE: TO RECEIVE BARS 8, 9, 10, & 11, YOU MUST ORDER OPTION KIT #700-040 SEPARATELY.

# BATTERY BOXES WELD-ON



- ★WELDS TO THE FRAME
- ★LIGHTWEIGHT STEEL CONSTRUCTION
- ★INCLUDES ALUMINUM CLAMP BAR, 2 J-BOLTS, & 2 LOCK NUTS

DESCRIPTION (INSIDE DIMENSIONS)	PART #
7 1/8" DEEP x 8 7/8" WIDE	499-900
7 1/8" DEEP x 11" WIDE	499-902

# BOLT-ON

- ★BOLT-ON DESIGN ALLOWS FOR ADJUSTMENT OF THE BOX ON THE FRAME
- ★LIGHTWEIGHT STEEL CONSTRUCTION
- ★INCLUDES ALUMINUM CLAMP BAR, 2 J-BOLTS, & 2 LOCK NUTS

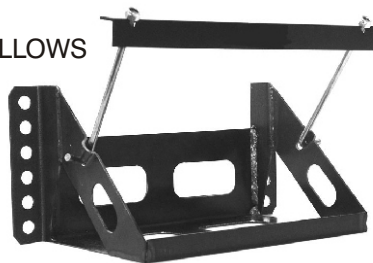

DESCRIPTION (INSIDE DIMENSIONS)	PART #
7 1/8" DEEP x 8 7/8" WIDE	499-901
7 1/8" DEEP x 11" WIDE	499-903

# WELD-ON GUSSETS

- ★1/8" THICK GUSSETS
- ★GREAT FOR CORNER BRACES
- ★STRENGTHENS ROLL CAGES

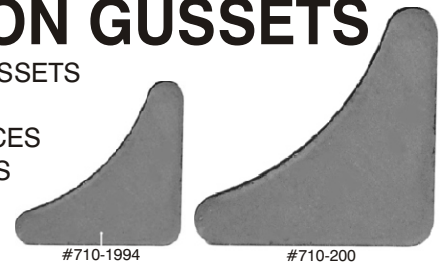

DESCRIPTION	PART #
2" x 2" GUSSETS, PRICED & SOLD IN 25's	710-200
1 3/4" x 1 3/4" GUSSET WITH SLOT*	710-1998
1 1/4" x 1 1/4" GUSSET WITH SLOT*	710-1994
3/4" x 3/4" GUSSET WITH SLOT*	710-199

\*THE BOTTOM 3 GUSSETS ARE PRICED EACH & SOLD IN BAGS OF 10 AND THEY HAVE A SMALL STARTING SLOT CUT OUT OF THEM

# LIGHTENED GUSSETS

- ★1/8" THICK, LIGHTENED GUSSETS
- ★GREAT FOR CORNER BRACES
- ★STRENGTHENS ROLL CAGES

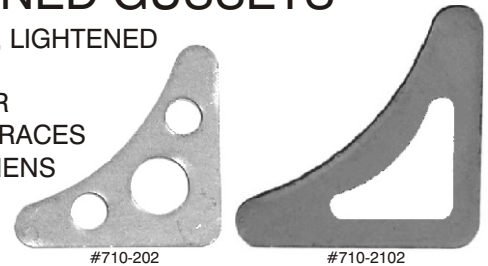

DESCRIPTION	PART #
2" x 2" GUSSETS, PRICED & SOLD IN 25's	710-202
2" x 2" GUSSET*	710-210
2 1/2" x 2 1/2" GUSSET *	710-2102
3" x 3" GUSSET*	710-2104
3 1/2" x 3 1/2" GUSSET*	710-2106
4" x 4" GUSSET*	710-2108

\*THE BOTTOM 5 GUSSETS ARE PRICED EACH & SOLD IN BAGS OF 10 AND THEY HAVE A COMPLETE TRIANGLE SLOT CUT OUT, WHILE THE #710-202 HAS 3 HOLES FOR LIGHTENING

# TUBE PLUGS

- ★AVAILABLE FOR ROUND, SQUARE, & RECTANGULAR TUBING
- ★SEALS ENDS OF TUBING
- ★PRICED EACH & SOLD IN PACKS OF 10

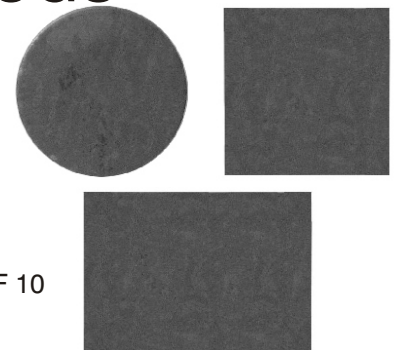

DESCRIPTION	PART #
1 1/4" DIAMETER ROUND PLUG	701-304
1 3/8" DIAMETER ROUND PLUG	701-306
1 1/2" DIAMETER ROUND PLUG	701-308
1 5/8" DIAMETER ROUND PLUG	701-310
1 3/4" DIAMETER ROUND PLUG	701-312
1" x 1" SQUARE PLUG	701-3202
1 1/4" x 1 1/4" SQUARE PLUG	701-3204
1 1/2" x 1 1/2" SQUARE PLUG	701-3206
2" x 2" SQUARE PLUG	701-3208
3" x 2" RECTANGLE PLUG	701-3214

Place your order at (479) 646-6988, Fax to (479) 646-5939, or visit [www.southwestspeed.com](http://www.southwestspeed.com)

# WELD-ON TABS

## UNIVERSAL FLAT TABS

- ★ TABS WELD TO FLAT SURFACES
- ★ PRICED EACH & SOLD IN PACKS OF 10

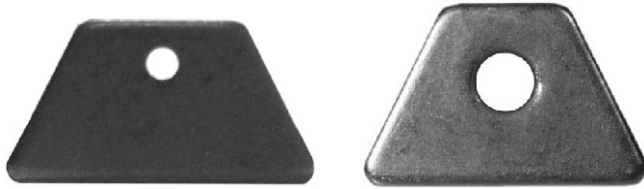

THICKNESS	HOLE I.D.	HEIGHT*	PART #
1/16"	3/16"	3/4"	701-017
1/8"	3/16"	3/4"	701-018
1/8"	1/4"	13/16"	701-0181
1/8"	1/2"	7/8"	701-039
3/16"	3/8"	7/8"	701-0398
3/16"	1/2"	7/8"	701-040
1/4"	1/2"	7/8"	701-041

\*HEIGHT IS MEASURED FROM CENTER OF HOLE TO BOTTOM OF TAB

## UNIVERSAL TRIANGLE TABS

- ★ TABS WELD TO FLAT SURFACES
- ★ PRICED EACH & SOLD IN PACKS OF 10



THICKNESS	HOLE I.D.	HEIGHT*	PART #
1/8"	3/8"	13/16"	701-0499
1/8"	1/2"	13/16"	701-050
3/16"	3/8"	13/16"	701-0503
3/16"	1/2"	13/16"	701-0504

\*HEIGHT IS MEASURED FROM CENTER OF HOLE TO BOTTOM OF TAB

## UNIVERSAL ROUND TABS WITH NOTCHES

- ★ TABS WELD TO ROUND TUBING
- ★ PRICED EACH & SOLD IN PACKS OF 10

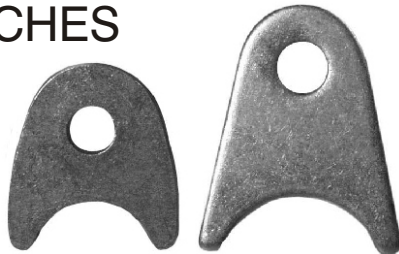

THICK	HOLE I.D.	HEIGHT*	WELDS TO	PART #
1/8"	1/4"	5/8"	1"	701-023
1/8"	3/8"	3/4"	1"	701-024
1/8"	1/2"	7/8"	1 1/4"	701-080
1/8"	1/2"	1 1/4"	1 1/4"	701-083
3/16"	1/2"	7/8"	1 1/4"	701-081
3/16"	3/8"	2 1/8"	2 1/8"	701-1062
3/16"	3/8"	1 3/4"	1 1/2"	701-105
3/16"	1/2"	7/8"	1 1/2"	701-031
3/16"	1/2"	1 3/4"	1 1/2"	701-107
3/8"	3/8"	7/8"	1 3/4"	701-100

\*HEIGHT IS MEASURED FROM CENTER OF HOLE TO EDGE OF TUBING

NOTE: FOR A CONSTANT STREAM OF NEW PRODUCTS & UP-TO-THE-SECOND PRICING, VISIT [WWW.SOUTHWESTSPEED.COM](http://WWW.SOUTHWESTSPEED.COM)

# WELD-ON TABS

## UNIVERSAL ROUND TABS

- ★ 4 DIFFERENT DESIGNS AVAILABLE
- ★ PART #'S 701-0331 - 701-020 ON THE LIST ARE PRICED EACH & SOLD IN PACKS OF 10
- ★ PART #'S 701-0451 - 701-0443 ON THE LIST ARE PRICED EACH & SOLD IN PACKS OF 4



THICKNESS	HOLE I.D.	HEIGHT*	PART #
<b>CENTERED ROUND TABS</b>			
1/8"	1/8"	3/4"	701-0331
1/8"	3/16"	3/4"	701-0332
1/8"	1/4"	3/4"	701-0333
1/8"	5/16"	3/4"	701-0334
1/8"	3/8"	1 1/8"	701-034
1/8"	1/2"	1 5/16"	701-035
3/16"	3/8"	1 1/8"	701-036
3/16"	1/2"	1 5/16"	701-037
1/4"	1/2"	1 5/16"	701-038
<b>OFFSET ROUND TABS</b>			
1/8"	1/4"	3/4"	701-019
1/8"	5/16"	3/4"	701-0191
1/8"	3/8"	3/4"	701-0192
3/16"	5/16"	3/4"	701-020
1/8"	1/2"	1 1/2"	701-0451
1/8"	5/8"	1 1/2"	701-0452
1/8"	3/4"	1 1/2"	701-0453
3/16"	1/2"	1 1/2"	701-0454
3/16"	5/8"	1 1/2"	701-0455
3/16"	3/4"	1 1/2"	701-0456
<b>CROWN-SHAPED ROUND TABS</b>			
1/8"	3/8"	1"	701-0445
3/16"	3/8"	1"	701-0446
<b>DIAMOND-SHAPED ROUND TABS</b>			
1/8"	3/8"	1"	701-0442
3/16"	3/8"	1"	701-0443

\*HEIGHT IS MEASURED FROM CENTER OF HOLE TO BOTTOM OF TAB

## UNIVERSAL TRICK TABS

- ★ FANCY TABS WELD TO TUBING FOR EASY MOUNTING OF COMPONENTS
- ★ PRICED EACH & SOLD IN PACKS OF 10

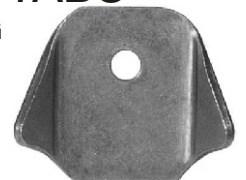

THICKNESS	HOLE I.D.	HEIGHT*	PART #
.085"	1/8"	7/8"	701-042
.085"	1/4"	7/8"	701-043
.085"	3/8"	7/8"	701-044
.085"	1/2"	7/8"	701-045
1/8"	1/8"	1"	701-026
1/8"	1/4"	1"	701-027
1/8"	3/8"	1"	701-028
1/8"	1/2"	1"	701-029

\*HEIGHT IS MEASURED FROM CENTER OF HOLE TO BOTTOM OF TAB

Place your order at (479) 646-6988, Fax to (479) 646-5939, or visit [www.southwestspeed.com](http://www.southwestspeed.com)

# WELD-ON TABS

## UNIVERSAL LONG TAB

- ★LONG UNIVERSAL TAB WELDS TO CHASSIS & IS CONVENIENT FOR MOUNTING NUMEROUS ITEMS
- ★7" IN TOTAL LENGTH
- ★1/8" THICK STEEL
- ★3/8" I.D. BOLT HOLE
- ★EXTRA HOLES PROVIDE LIGHTER DESIGN

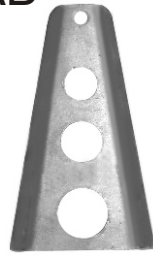

**PART #701-200**

## BRAKE LINE TABS



- ★WELDS TO CHASSIS TO HOLD BRAKE LINE FITTINGS IN PLACE
- ★PRICED EACH & SOLD IN BAGS OF 10

DESCRIPTION	PART #
TAB, 7/16" HOLE FOR 1/8" NPT HOSE	701-005
TAB, 5/8" HOLE FOR #301-025 FITTING	701-006

## UNIVERSAL CHANNEL TABS

- ★1" & 1 1/2" CHANNELS
- ★PRE-DRILLED WITH 3/8" BOLT HOLES
- ★GREAT FOR MOUNTING MOTOR PLATES, FUEL CELLS & MANY OTHER ITEMS
- ★PRICED EACH & SOLD IN BAGS OF 10

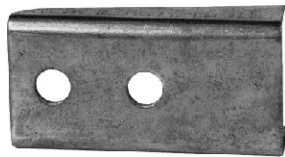

DESCRIPTION	PART #
WELD TAB, 1" CHANNEL, 2 1/2" LONG	701-055
WELD TAB, 1 1/2" CHANNEL, 2" LONG	701-065
WELD TAB, 1 1/2" CHANNEL, 3" LONG	701-067
WELD TAB, 1 1/2" CHANNEL, 4 3/4" LONG	701-068

## TRAILING ARM TABS

- ★1 POSITION & 2 POSITION MOUNTS ARE NOTCHED TO FIT 3 1/2" O.D. REAR END TUBES
- ★3/16" THICK STEEL WITH 5/8" OR 3/4" I.D. HOLES
- ★COMMONLY USED TO FABRICATE FLOATERS
- ★SOLD INDIVIDUALLY

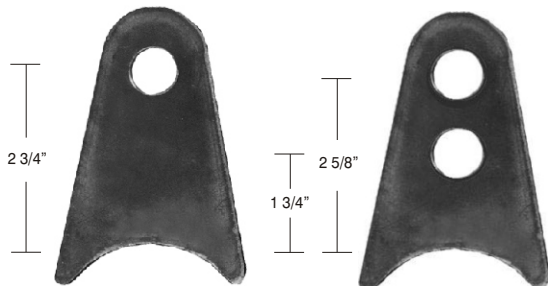

DESCRIPTION	PART #
1 POSITION TAB, 5/8" HOLE	570-850
2 POSITION TAB, 3/4" HOLES	570-851

# WELD-IN THREADED BOSSES

- ★SIMPLIFIES MOUNTING OF MANY COMPONENTS
- ★9/16", 3/4", 7/8", & 1" DIAMETERS
- ★3/8", 1/2", 5/8", & 3/4" RIGHT HAND THREADS



OUTSIDE DIAMETER	THREADS	LENGTH	PART #
9/16"	3/8"-24R	1"	701-520
3/4"	1/2"-20R	1"	701-5350
3/4"	1/2"-20R	1 1/4"	701-5351
3/4"	1/2"-20R	1 1/2"	701-5352
3/4"	1/2"-20R	2"	701-5354
3/4"	1/2"-20R	2 1/2"	701-5356
3/4"	1/2"-20R	3"	701-5358
7/8"	5/8"-18R	1"	701-536
7/8"	5/8"-18R	1 5/8"	701-5376
7/8"	5/8"-18R	2"	701-538
7/8"	5/8"-18R	2 1/2"	701-540
7/8"	5/8"-18R	3"	701-542
7/8"	5/8"-18R	4"	701-544
1"	3/4"-16R	1"	701-546
1"	3/4"-16R	1 1/2"	701-548
1"	3/4"-16R	2"	701-549
1"	3/4"-16R	2 1/2"	701-550
1"	3/4"-16R	3"	701-552
1"	3/4"-16R	4"	701-554

# WELD-ON STEERING COLUMN MOUNTS

- ★LIGHTWEIGHT STEEL CONSTRUCTION
- ★3/4" ROD END SLOTS
- ★COLUMN MOUNTS WELD TO THE DASH BAR
- ★MEASUREMENTS ARE TAKEN FROM THE CENTER OF THE SLOT TO THE EDGE OF THE TUBE

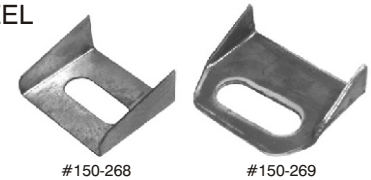

#150-268

#150-269

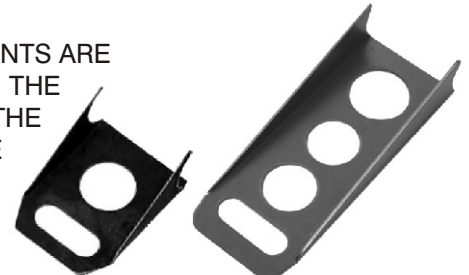

#150-271

#150-275

DESCRIPTION	PART #
WELD-ON MOUNT, 1 1/4" SLOT-TO-EDGE	150-268
WELD-ON MOUNT, 1 3/4" SLOT-TO-EDGE	150-269
WELD-ON MOUNT, 2 3/4" SLOT-TO-EDGE	150-271
WELD-ON MOUNT, 6 3/4" SLOT-TO-EDGE	150-275

Place your order at (479) 646-6988, Fax to (479) 646-5939, or visit [www.southwestspeed.com](http://www.southwestspeed.com)



# TORQUE LINKS

## SMALL RUBBER BISCUIT BAR

- ★NO OTHER TORQUE ABSORBING DEVICE PUTS MORE MODIFIEDS IN VICTORY LANE & MORE MONEY IN RACERS' POCKETS THAN THE SOUTHWEST SPEED RUBBER BISCUIT BAR
- ★LIGHTWEIGHT PROGRESSIVE DESIGN WITH 2.125" O.D. RUBBER SPRINGS
- ★3 RUBBER RATES AVAILABLE



NOTE: WHEN ORDERING, PLEASE SPECIFY THE DESIRED LENGTH (CENTER-TO-CENTER) & SPRING RUBBER RATE

DESCRIPTION	PART #
SMALL RUBBER BISCUIT BAR ASSEMBLY	570-800
SMALL RUBBER ONLY, BLUE, SOFT (60*)	570-739
SMALL RUBBER ONLY, RED, MEDIUM (70*)	570-740
SMALL RUBBER ONLY, BLACK, HARD (88*)	570-741

\*SPRING RATE DETERMINED BY DUROMETER

## LARGE RUBBER SPRING BARS

- ★BARS REPLACE 3/4" 3RD LINKS TO ABSORB TORQUE & TUNE THE CHASSIS
- ★USE 3.345" O.D. DUAL RUBBER SPRINGS THAT ARE AVAILABLE IN 3 DIFFERENT RATES
- ★OUTER RUBBER BUSHING IS DESIGNED TO ABSORB BRAKING FORCES
- ★2 DIFFERENT DESIGNS AVAILABLE:
  - \*THE ORIGINAL, 3 TUBE BAR IS AN EFFICIENT, PROGRESSIVE DESIGN THAT HAS BEEN USED FOR YEARS
  - \*THE WISHBONE BAR IS ONE OF THE SIMPLEST, YET MOST EFFECTIVE DESIGNS ON THE MARKET



#570-790  
ORIGINAL, 3 TUBE  
LARGE RUBBER  
TORQUE LINK



#570-825  
WISHBONE  
LARGE RUBBER  
TORQUE LINK

NOTE: WHEN ORDERING, PLEASE SPECIFY THE DESIRED LENGTH (CENTER-TO-CENTER) & SPRING RUBBER RATE

DESCRIPTION	PART #
3 TUBE RUBBER SPRING BAR ASSEMBLY	570-790
WISHBONE RUBBER SPRING BAR ASSY.	570-825
LARGE RUBBER ONLY, BLUE, SOFT (60*)	570-735
LARGE RUBBER ONLY, RED, MEDIUM (70*)	570-736
LARGE RUBBER ONLY, BLACK, HARD (88*)	570-737

\*SPRING RATE DETERMINED BY DUROMETER

YOU CAN FIND THE TORQUE LINK MOUNTS ON PAGE 209 & 216-217

# TORQUE LINKS

## COIL SPRING TORQUE LINKS

- ★LINKS REPLACE 3/4" 3RD LINKS TO ABSORB TORQUE & TUNE THE CHASSIS
- ★5" O.D. X 4" OR 7" TALL SPRINGS AVAILABLE
- ★SPRING RATES AVAILABLE FROM 500-1200 LBS., IN 100 LB. INCREMENTS
- ★OUTER RUBBER BUSHING IS DESIGNED TO ABSORB BRAKING FORCES



NOTE: WHEN ORDERING, PLEASE SPECIFY THE DESIRED LENGTH (CENTER-TO-CENTER) & COIL SPRING RATE

DESCRIPTION	PART #
4" SINGLE SPRING TORQUE LINK ASSY.	570-760
7" SINGLE SPRING TORQUE LINK ASSY.	570-770

## AIR TORQUE LINK, FACTOR 2

- ★THE FACTOR 2 AIRE LINC IS A TWO WAY PROGRESSIVE ABSORBER
- ★REPLACES 3/4" 3RD LINKS TO ABSORB TORQUE & TUNE THE CHASSIS
- ★USES AIR PRESSURE TO ABSORB THE FORCES, RATHER THAN A RUBBER OR A COIL SPRING
- ★3 1/2" DIAMETER HARD ALUMINUM CASE
- ★AIR PRESSURE ALLOWS YOU TO HAVE A VAST ARRAY OF DIFFERENT RATES WITH THE SAME HARDWARE



PART #570-808

WHEN ORDERING, PLEASE SPECIFY THE LENGTH (CENTER-TO-CENTER)

## 3RD LINK RUBBER BUSHING TYPE ABSORBER

- ★REPLACES SOLID LINK
- ★CUSHIONS TORQUE
- ★3/4"-16 THREAD
- ★1" O.D. PIVOTS
- ★SWEDGED TUBE SOLD SEPARATELY



PART #570-750

## RUBBER SNUBBER BAR

- ★RUBBER CUSHIONED
- ★PULL APART DESIGN
- ★3/4" ROD ENDS
- ★STANDARD 18" CENTER-TO-CENTER

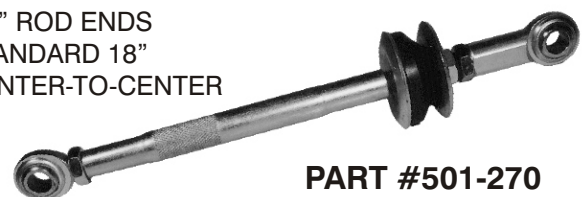

PART #501-270

Place your order at (479) 646-6988, Fax to (479) 646-5939, or visit [www.southwestspeed.com](http://www.southwestspeed.com)

# TORQUE LINK PARTS

## SMALL RUBBER SPRINGS

- ★2.125" O.D. SPRING RUBBERS
- ★USED ON THE ACCELERATION & THE BRAKING OF THE #570-800
- ★RATES ARE DETERMINED BY A DUROMETER



DESCRIPTION	PART #
SMALL RUBBER, BLUE, SOFT (60 RATE)	570-739
SMALL RUBBER, RED, MEDIUM (70 RATE)	570-740
SMALL RUBBER, BLACK, HARD (88 RATE)	570-741

## LARGE RUBBER SPRINGS

- ★3.345" O.D. SPRING RUBBERS
- ★AVAILABLE IN SINGLE & DUAL VERSIONS
- ★THE DUAL IS USED ON THE ACCELERATION & OF THE #570-790, #570-825, & MANY OTHER TORQUE LINKS ON THE MARKET
- ★RATES ARE DETERMINED BY A DUROMETER



DESCRIPTION	PART #
SINGLE RUBBER, BLUE, SOFT (60 RATE)	570-730
SINGLE RUBBER, RED, MEDIUM (70 RATE)	570-731
SINGLE RUBBER, BLACK, HARD (88 RATE)	570-732
DUAL RUBBER, BLUE, SOFT (60 RATE)	570-735
DUAL RUBBER, RED, MEDIUM (70 RATE)	570-736
DUAL RUBBER, BLACK, HARD (88 RATE)	570-737

## MISC. TORQUE LINK PARTS



DESCRIPTION	PART #
3" OD RUBBER BRAKE BUSHING, SOFT	570-752
3" OD RUBBER BRAKE BUSHING, MEDIUM	570-753
SMALL STEEL WASHER, 3/4" BORE	570-754
LARGE STEEL WASHER, 5/8" BORE	570-755
LARGE STEEL WASHER, 3/4" BORE	570-756
3/4" MALE, RIGHT-HAND ROD END	103-012
3/4" MALE, LEFT-HAND ROD END	103-022
3/4" RIGHT-HAND JAM NUT	102-942
3/4" LEFT-HAND JAM NUT	102-952
3/4" RIGHT-HAND NYLOCK JAM NUT	102-941

YOU CAN FIND THE TORQUE LINK MOUNTS ON PAGE 209 & 216-217

# TORQUE ARMS

- ★SOUTHWEST SPEED TORQUE ARMS ARE ADJUSTABLE WITH 4 DIFFERENT HOLES, EACH 2" APART
- ★MEASUREMENTS ARE TAKEN FROM THE CENTER OF THE REAR END TUBE TO THE CENTER OF THE SHOCK MOUNT HOLE(S)
- ★AVAILABLE FOR 9" FORD & QUICK CHANGE REAR ENDS
- ★LIGHTWEIGHT STEEL CONSTRUCTION
- ★USES 5/8" ROD ENDS THAT CAN BE THREADED IN & OUT TO ADJUST THE PINION ANGLE

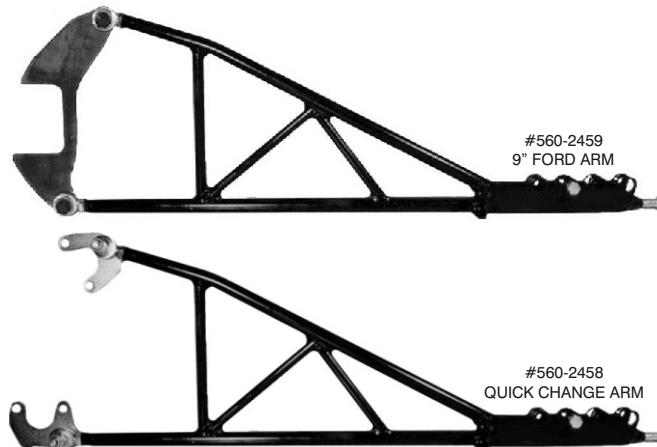

DESCRIPTION	PART #
9" FORD ARM, ADJUSTABLE, 25" - 31"	560-2459
9" FORD ARM, ADJUSTABLE, 29" - 35"	560-2479
9" FORD ARM, ADJUSTABLE, 33" - 39"	560-2499
QUICK CHANGE ARM, ADJUST., 26" - 32"	560-2458
QUICK CHANGE ARM, ADJUST., 30" - 36"	560-247
QUICK CHANGE ARM, ADJUST., 34" - 40"	560-249

# TORQUE ARM BRACKETS

- ★REPLACEMENT BRACKETS FOR 9" FORD & QUICK CHANGE TORQUE ARMS
- ★LIGHTWEIGHT STEEL CONSTRUCTION (3/8" THICK ON 9" FORD & 1/4" THICK ON Q.C.)
- ★TWO 9" FORD BRACKETS ARE AVAILABLE; ONE FOR MOUNTING ON THE SQUARE PART OF THE CENTER SECTION & ONE FOR MOUNTING ON THE ROUND PART CLOSER TO THE TUBE OR TO THE TUBE ITSELF



DESCRIPTION	PART #
9" FORD BRACKET, SQUARE CUT	560-245
9" FORD BRACKET, ROUND CUT	560-244
QUICK CHANGE BRACKET, LOWER	560-260
QUICK CHANGE BRACKET, UPPER	560-261

Place your order at (479) 646-6988, Fax to (479) 646-5939, or visit [www.southwestspeed.com](http://www.southwestspeed.com)

# TORQUE ARM PARTS

## 9" FORD ADAPTER

- ★ADAPTS QUICK CHANGE TORQUE ARMS TO 9" FORD REAR ENDS
- ★WELDS ON THE SQUARE PART OF THE CENTER SECTION



**PART #560-202**



## U-CHAIN

- ★STOPS TORQUE ARM UNDER BRAKING
- ★BRIGHT ZINC PLATING
- ★WORKS WITH QUICK CHANGE & 9" FORD TORQUE ARMS

**PART #560-210**

## TORQUE ARM BRACES

- ★BOLTS TO TORQUE ARM BRACKET & FRAME TO PREVENT SIDE TO SIDE MOVEMENT
- ★LIGHTWEIGHT ALUMINUM CONSTRUCTION
- ★3/8" LEFT & RIGHT HAND THREADS
- ★COMES WITH ROD ENDS & JAM NUTS



DESCRIPTION	PART #
ADJUSTABLE BRACE, 11" C-TO-C	560-213
ADJUSTABLE BRACE, 12" C-TO-C	560-214

## TORQUE ARM BRACE CLAMP



- ★LIGHTWEIGHT ALUMINUM CONSTRUCTION
- ★3/8" BOLT HOLE
- ★PREVENTS FLEX
- ★CLAMPS TO 3" O.D. TUBES

**PART #560-268**

## UPPER SHOCK BRACKET - 5TH COIL

- ★UPPER 5TH OR 6TH SHOCK BRACKET
- ★FITS 1 1/2" TUBING
- ★LIGHTWEIGHT ALUMINUM CONSTRUCTION

**PART #560-204**



# SPRING BARS

★SPRING BAR DESIGNED TO ABSORB TORQUE



DESCRIPTION	PART #
SPRING BAR, 300 LBS.	560-196
SPRING BAR, 500 LBS.	560-197
SPRING BAR, 700 LBS.	560-198

## SPRING BAR FRONT MOUNTS

★USED TO ATTACH LINKAGES TO THE FRONT OF SPRING BARS; 3/4" THROUGH HOLES



DESCRIPTION	PART #
2 POSITION LINKAGE MOUNT	560-185
5 POSITION LINKAGE MOUNT	560-187

## SPRING BAR REAR MOUNTS

### 9" FORD

- ★MOUNTS SPRING BAR TO EITHER LEFT SIDE OR RIGHT SIDE OF 9" FORD REAR ENDS
- ★MOUNTS FIT ALL SPRING BARS



DESCRIPTION	PART #
9" FORD, LEFT SIDE	560-190
9" FORD, RIGHT SIDE	560-192

## QUICK CHANGE

- ★MOUNTS SPRING BAR TO EITHER LEFT SIDE OR RIGHT SIDE OF QUICK CHANGE REAR ENDS
- ★MOUNTS FIT ALL SPRING BARS



DESCRIPTION	PART #
QUICK CHANGE, LEFT SIDE	560-188
QUICK CHANGE, RIGHT SIDE	560-189

Place your order at (479) 646-6988, Fax to (479) 646-5939, or visit [www.southwestspeed.com](http://www.southwestspeed.com)



# FLAT BOLT SPACERS

BORE	O.D.	THICK	STEEL #	ALUM. #
3/16"	5/16"	.062"	503-8061	503-8081
3/16"	5/16"	.125"	503-8062	503-8082
3/16"	5/16"	.187"	503-8063	503-8083
3/16"	5/16"	.250"	503-8064	503-8084
3/16"	5/16"	.312"	503-8065	503-8085
3/16"	5/16"	.375"	503-8066	503-8086
3/16"	5/16"	.437"	503-8067	503-8087
3/16"	5/16"	.500"	503-8068	503-8088
3/16"	5/16"	.562"	503-8069	503-8089
3/16"	5/16"	.625"	503-8070	503-8090
3/16"	5/16"	.687"	503-8071	503-8091
3/16"	5/16"	.750"	503-8072	503-8092
3/16"	5/16"	.875"	503-8074	503-8094
3/16"	5/16"	1.000"	503-8076	503-8096
1/4"	1/2"	.062"	503-8101	503-8121
1/4"	1/2"	.125"	503-8102	503-8122
1/4"	1/2"	.187"	503-8103	503-8123
1/4"	1/2"	.250"	503-8104	503-8124
1/4"	1/2"	.312"	503-8105	503-8125
1/4"	1/2"	.375"	503-8106	503-8126
1/4"	1/2"	.437"	503-8107	503-8127
1/4"	1/2"	.500"	503-8108	503-8128
1/4"	1/2"	.562"	503-8109	503-8129
1/4"	1/2"	.625"	503-8110	503-8130
1/4"	1/2"	.687"	503-8111	503-8131
1/4"	1/2"	.750"	503-8112	503-8132
1/4"	1/2"	.875"	503-8114	503-8134
1/4"	1/2"	1.000"	503-8116	503-8136
5/16"	5/8"	.062"	503-8141	503-8161
5/16"	5/8"	.125"	503-8142	503-8162
5/16"	5/8"	.187"	503-8143	503-8163
5/16"	5/8"	.250"	503-8144	503-8164
5/16"	5/8"	.312"	503-8145	503-8165
5/16"	5/8"	.375"	503-8146	503-8166
5/16"	5/8"	.437"	503-8147	503-8167
5/16"	5/8"	.500"	503-8148	503-8168
5/16"	5/8"	.562"	503-8149	503-8169
5/16"	5/8"	.625"	503-8150	503-8170
5/16"	5/8"	.687"	503-8151	503-8171
5/16"	5/8"	.750"	503-8152	503-8172
5/16"	5/8"	.875"	503-8154	503-8174
5/16"	5/8"	1.000"	503-8156	503-8176
3/8"	5/8"	.062"	503-8181	503-8201
3/8"	5/8"	.125"	503-8182	503-8202
3/8"	5/8"	.187"	503-8183	503-8203
3/8"	5/8"	.250"	503-8184	503-8204
3/8"	5/8"	.312"	503-8185	503-8205
3/8"	5/8"	.375"	503-8186	503-8206
3/8"	5/8"	.437"	503-8187	503-8207
3/8"	5/8"	.500"	503-8188	503-8208
3/8"	5/8"	.562"	503-8189	503-8209
3/8"	5/8"	.625"	503-8190	503-8210
3/8"	5/8"	.687"	503-8191	503-8211
3/8"	5/8"	.750"	503-8192	503-8212
3/8"	5/8"	.875"	503-8194	503-8214
3/8"	5/8"	1.000"	503-8196	503-8216
3/8"	5/8"	1.125"	503-8198	503-8218
3/8"	5/8"	1.250"	503-8200	503-8220
3/8"	1/2"	.062"	503-9501	-
3/8"	1/2"	.125"	503-9502	-
3/8"	1/2"	.187"	503-9503	-
3/8"	1/2"	.250"	503-9504	-
3/8"	1/2"	.312"	503-9505	-
3/8"	1/2"	.375"	503-9506	-
3/8"	1/2"	.437"	503-9507	-
3/8"	1/2"	.500"	503-9508	-
3/8"	1/2"	.562"	503-9509	-
3/8"	1/2"	.625"	503-9510	-
3/8"	1/2"	.687"	503-9511	-
3/8"	1/2"	.750"	503-9512	-
3/8"	1/2"	.875"	503-9514	-
3/8"	1/2"	1.000"	503-9516	-
3/8"	5/8"	.312"	-	503-820
3/8"	3/4"	1.312"	-	503-8009
7/16"	9/16"	.062"	503-9520	-
7/16"	9/16"	.125"	503-9521	-
7/16"	9/16"	.187"	503-9522	-
7/16"	9/16"	.250"	503-9523	-
7/16"	9/16"	.312"	503-9524	-
7/16"	9/16"	.375"	503-9525	-
7/16"	9/16"	.437"	503-9526	-
7/16"	9/16"	.500"	503-9527	-
7/16"	9/16"	.562"	503-9528	-
7/16"	9/16"	.625"	503-9529	-
7/16"	9/16"	.687"	503-9530	-
7/16"	9/16"	.750"	503-9531	-
7/16"	9/16"	.875"	503-9533	-
7/16"	9/16"	1.000"	503-9535	-
7/16"	5/8"	.625"	503-995	-
7/16"	3/4"	.062"	503-8221	503-8241
7/16"	3/4"	.125"	503-8222	503-8242
7/16"	3/4"	.187"	503-8223	503-8243
7/16"	3/4"	.250"	503-8224	503-8244
7/16"	3/4"	.312"	503-8225	503-8245
7/16"	3/4"	.375"	503-8226	503-8246
7/16"	3/4"	.437"	503-8227	503-8247
7/16"	3/4"	.500"	503-8228	503-8248
7/16"	3/4"	.562"	503-8229	503-8249
7/16"	3/4"	.625"	503-8230	503-8250
7/16"	3/4"	.687"	503-8231	503-8251
7/16"	3/4"	.750"	503-8232	503-8252
7/16"	3/4"	.875"	503-8234	503-8254
7/16"	3/4"	1.000"	503-8236	503-8256
7/16"	1"	2.400"	-	504-210

BORE	O.D.	THICK	STEEL #	ALUM. #
1/2"	3/4"	.062"	503-998	503-8291
1/2"	3/4"	.125"	503-999	503-8292
1/2"	3/4"	.187"	504-000	503-8293
1/2"	3/4"	.250"	504-0001	503-8294
1/2"	3/4"	.312"	504-0009	503-8295
1/2"	3/4"	.375"	504-001	503-8296
1/2"	3/4"	.437"	504-0011	503-8297
1/2"	3/4"	.500"	504-002	503-8298
1/2"	3/4"	.562"	504-0029	503-8299
1/2"	3/4"	.625"	504-003	503-8300
1/2"	3/4"	.687"	504-0039	503-8301
1/2"	3/4"	.750"	504-004	503-8302
1/2"	3/4"	.875"	504-005	503-8304
1/2"	3/4"	1.000"	504-006	503-8306
1/2"	3/4"	1.125"	504-007	-
1/2"	3/4"	1.250"	504-008	-
1/2"	3/4"	1.375"	504-009	503-829
1/2"	3/4"	1.500"	504-010	-
1/2"	3/4"	4.875"	504-0117	-
1/2"	7/8"	1.250"	-	504-080
1/2"	1"	1.000"	-	503-8310
1/2"	1"	2.000"	-	503-8318
1/2"	1 1/2"	.750"	-	503-8328
5/8"	7/8"	.062"	504-0120	503-835
5/8"	7/8"	.125"	504-0121	503-836
5/8"	7/8"	.187"	504-0122	503-837
5/8"	7/8"	.250"	504-0123	503-838
5/8"	7/8"	.375"	504-0124	503-839
5/8"	7/8"	.500"	504-0125	503-840
5/8"	7/8"	.625"	504-0126	503-841
5/8"	7/8"	.750"	504-0127	503-842
5/8"	7/8"	.875"	504-0128	503-843
5/8"	7/8"	1.000"	504-0129	503-844
5/8"	1"	.357"	504-0132	-
3/4"	1"	.062"	504-015	503-849
3/4"	1"	.125"	504-016	503-850
3/4"	1"	.187"	504-017	503-851
3/4"	1"	.200"	504-019	-
3/4"	1"	.250"	504-0191	503-852
3/4"	1"	.300"	504-020	-
3/4"	1"	.375"	504-021	503-854
3/4"	1"	.500"	504-023	503-856
3/4"	1"	.625"	504-025	503-858
3/4"	1"	.750"	504-027	503-860
3/4"	1"	.875"	504-0275	503-862
3/4"	1"	1.000"	504-028	503-864
3/4"	1"	1.125"	504-029	503-866
3/4"	1"	1.250"	504-030	503-868
3/4"	1"	1.375"	-	503-870
3/4"	1"	1.500"	-	503-872
3/4"	1"	4.875"	504-0317	-

- ★ FLAT SPACERS TAKE UP SPACE BETWEEN BRACKETS
- ★ FLAT ON BOTH ENDS
- ★ PRICED EACH & SOLD IN PACKS OF 10



# TAPERED BOLT SPACERS

- ★ FOR SPACING ROD ENDS AWAY FROM BRACKETS
- ★ ALL SPACERS ARE PRICED EACH; #504-110 & #504-100 ARE SOLD IN PACKS OF 8, ALL OTHERS ARE SOLD IN PACKS OF 10
- ★ THE "TAP" DESIGNATES THAT THE OUTSIDE IS TAPERED

BORE	O.D.	THICK	STEEL #	ALUM. #
3/16"	7/16" TAP	.250"	503-7272	503-7472
1/4"	1/2" TAP	.250"	503-7275	503-7475
5/16"	5/8" TAP	.312"	503-728	503-748
3/8"	3/4" TAP	.312"	503-730	503-750
7/16"	3/4" TAP	.375"	503-731	503-751
1/2"	7/8" TAP	.375"	503-732	503-752
1/2"	7/8" TAP	.500"	503-7321	503-7521
5/8"	1" TAP	.375"	503-734	503-754
5/8"	1" TAP	.437"	504-110	504-100
3/4"	1 1/4" TAP	.750"	504-1026	-
3/4"	1 1/4" TAP	1.500"	-	504-1029
3/4"	1 3/8" TAP	.437"	503-736	503-756
3/4"	1 1/2" TAP	.500"	-	503-900
3/4"	1 1/2" TAP	.625"	-	503-902
3/4"	1 1/2" TAP	.750"	-	503-904
3/4"	1 1/2" TAP	.875"	-	503-906
3/4"	1 1/2" TAP	1.000"	-	503-908
3/4"	1 1/2" TAP	1.125"	-	503-910
3/4"	1 1/2" TAP	1.250"	-	503-912
3/4"	1 1/2" TAP	1.375"	-	503-914
3/4"	1 1/2" TAP	1.500"	-	503-916
3/4"	1 1/2" TAP	1.625"	-	503-918
3/4"	1 1/2" TAP	1.750"	-	503-920
3/4"	1 1/2" TAP	1.875"	-	503-922
3/4"	1 1/2" TAP	2.000"	-	503-924



# ROD END REDUCERS

- ★ USED TO REDUCE ROD END BORES OR OTHER MOUNTING HOLES
- ★ AVAILABLE IN 2 DIFFERENT STYLES:



- ★ "A" = REDUCERS THAT FIT ENTIRELY IN THE ROD END BALL
- ★ "B" = REDUCERS THAT SLIP IN THE SIDES OF THE ROD END BALL OR OTHER MOUNTING HOLE
- ★ AVAILABLE FOR 5/8" & 3/4" BORE ROD ENDS OR MOUNTING HOLES
- ★ PRICED EACH & SOLD IN PACKS OF 10

DESCRIPTION	"A" #	"B" #
REDUCES 5/8" BORE TO 1/2" BOLT, ALUM.	504-193	504-051
REDUCES 5/8" BORE TO 1/2" BOLT, STEEL	504-194	504-050
REDUCES 3/4" BORE TO 1/2" BOLT, ALUM.	504-195	504-060
REDUCES 3/4" BORE TO 1/2" BOLT, STEEL	504-196	504-059
REDUCES 3/4" BORE TO 5/8" BOLT, ALUM.	504-197	504-065
REDUCES 3/4" BORE TO 5/8" BOLT, STEEL	504-198	504-064

# HIGH MISALIGNMENT SPACERS

- ★ ALLOWS ROD ENDS TO WORK AT THE MOST ADVERSE ANGLES
- ★ "SLEEVE O.D." REPRESENTS THE BALL THAT THE SPACER WILL SLIP IN & "LIP WIDTH" IS THE EXTRA WIDTH THAT THE SPACER STICKS OUT FROM THE ROD END BALL



BORE	SLEEVE O.D.	LIP WIDTH	STEEL #	ALUM. #
1/4"	5/16"	.330"	503-764	503-784
1/4"	3/8"	.360"	503-766	503-786
5/16"	3/8"	.360"	503-768	503-788
5/16"	7/16"	.400"	503-769	503-789
3/8"	1/2"	.430"	503-770	503-790
1/2"	5/8"	.490"	503-772	503-792
1/2"	3/4"	.510"	503-774	503-794
5/8"	3/4"	.510"	503-776	503-796
1/2"	1"	.810"	503-7764	503-7964
5/8"	1"	.810"	503-7766	503-7966
3/4"	1"	.810"	503-7767	503-7967

- ★ PRICED EACH & SOLD IN PACKS OF 10

Place your order at (479) 646-6988, Fax to (479) 646-5939, or visit [www.southwestspeed.com](http://www.southwestspeed.com)

# PANHARD RODS/J-BARS SOLID J-BARS

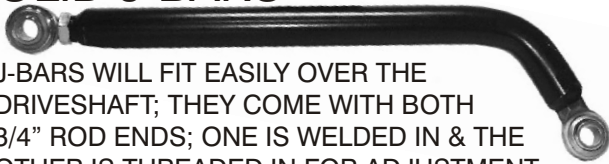

- ★ J-BARS WILL FIT EASILY OVER THE DRIVESHAFT; THEY COME WITH BOTH 3/4" ROD ENDS; ONE IS WELDED IN & THE OTHER IS THREADED IN FOR ADJUSTMENT
- ★ LENGTHS ARE MEASURED CENTER OF ROD END TO CENTER OF ROD END

DESCRIPTION	PART #
J-BAR, 18 1/2" CENTER-CENTER	570-598
J-BAR, 19 1/2" CENTER-CENTER	570-599
J-BAR, 20 1/2" CENTER-CENTER	570-600
J-BAR, 21 1/2" CENTER-CENTER	570-601
J-BAR, 22 1/2" CENTER-CENTER	570-602
J-BAR, 23 1/2" CENTER-CENTER	570-603
J-BAR, 24 1/2" CENTER-CENTER	570-604
J-BAR, 25 1/2" CENTER-CENTER	570-605
J-BAR, 26 1/2" CENTER-CENTER	570-606
J-BAR, UNWELDED KIT (CUT TO LENGTH)*	570-608

\*SEE THE BOTTOM RIGHT OF THIS PAGE

# RUBBER BUSHING J-BARS

- ★ ADJUSTABLE RUBBER BUSHING PANHARD BARS
- ★ RUBBER DESIGN CUSHIONS CORNER ENTRY
- ★ BARS COME PRE-LOADED & THE PRE-LOAD CAN BE ADJUSTED
- ★ COME W/ BOTH 3/4" ROD ENDS, ONE IS WELDED IN & ONE IS THREADED ON FOR ADJUSTMENT
- ★ LENGTHS ARE MEASURED CENTER OF ROD END TO CENTER OF ROD END WITH THE FEMALE ROD END SCREWED ALL THE WAY ON FOR THE SHORTEST LENGTH
- ★ AVAILABLE IN THE ORIGINAL DESIGN & THE EXTRA-CLEARANCE DESIGN, WHICH IS DESIGNED TO GIVE AN EXTRA 1" OF CLEARANCE OVER THE DRIVESHAFT



CENTER-TO-CENTER LENGTH	ORIGINAL DESIGN	EXTRA CLEARANCE
17" TO 20"	570-612	570-6123
18" TO 21"	570-611	570-6113
19" TO 22"	570-610	570-6103
20" TO 23"	570-609	570-6093
21" TO 24"	-	570-6083

YOU CAN FIND THE "SHORT BARS" (OR SWEDGED TUBES) ON PAGE 50 & THE ROD ENDS & JAM NUTS ON PAGE 51

YOU CAN FIND THE PANHARD BAR MOUNTS ON PAGE 208 & 216-217

# PANHARD RODS/J-BARS ADJUSTABLE SOLID J-BARS

- ★ EXCLUSIVE ADJUSTABLE DESIGN ALLOWS THE BAR TO ADJUSTED WHILE IT IS STILL MOUNTED
- ★ BARS COME WITH BOTH 3/4" ROD ENDS, ONE IS WELDED IN & THE OTHER IS THREADED IN THE ADJUSTER FOR EVEN MORE ADJUSTMENT
- ★ LENGTHS ARE MEASURED CENTER OF ROD END TO CENTER OF ROD END SCREWED ALL THE WAY IN FOR THE SHORTEST LENGTH
- ★ THE ADJUSTER GIVES 2" OF ADJUSTMENT
- ★ AVAILABLE IN THE ORIGINAL DESIGN & THE EXTRA-CLEARANCE DESIGN, WHICH IS DESIGNED TO GIVE AN EXTRA 1" OF CLEARANCE OVER THE DRIVESHAFT

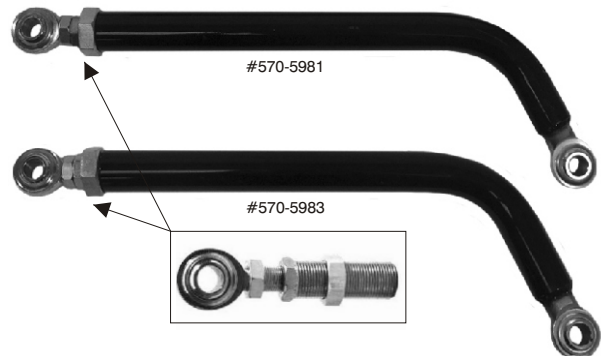

CENTER-TO-CENTER LENGTH	ORIGINAL DESIGN	EXTRA CLEARANCE
18 1/2" TO 20 1/2"	570-5981	570-5983
20" TO 22"	570-6001	570-6003
21" TO 23"	570-6011	570-6013
22" TO 24"	570-6021	570-6023
23" TO 25"	570-6031	570-6033
24 1/2" TO 26 1/2"	570-6041	570-6043
25 1/2" TO 27 1/2"	570-6051	570-6053

\*PART #570-5982 IS THE ADJUSTER ONLY; IT COMES WITH THE ADJUSTER JAM NUT, BUT NOT THE ROD END OR THE OUTER STEEL JAM NUT

# UNWELDED (CUT-TO-LENGTH) SOLID J-BAR

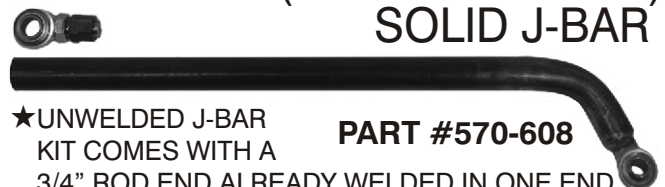

- ★ UNWELDED J-BAR KIT COMES WITH A 3/4" ROD END ALREADY WELDED IN ONE END, A THREADED BOSS TO WELD IN THE OTHER END AFTER THE DESIRED LENGTH IS REACHED, AND A 3/4" ROD END & JAM NUT TO PUT IN THE BOSS
- ★ BAR MEASURES 27" FROM THE CENTER OF THE ROD END TO THE UNWELDED END OF THE BAR

# 33° BEND SOLID J-BAR

- ★ 33° BEND, 27 3/4" CENTER-TO-CENTER WITH BOTH SIDES THREADED FOR ADJUSTMENT
- ★ COMES W/ 3/4" ROD ENDS & JAM NUTS

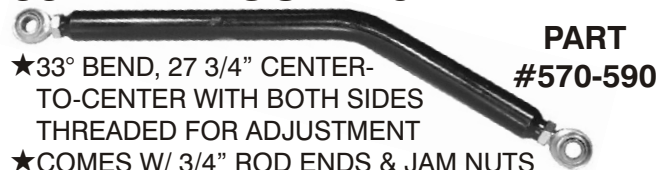

Place your order at (479) 646-6988, Fax to (479) 646-5939, or visit [www.southwestspeed.com](http://www.southwestspeed.com)

# SWING ARMS

- ★2 DESIGNS AVAILABLE:  
ONE WITH A WELDED REAR ROD END AND ONE WITH A THREADED REAR ROD END
- ★BOTH DESIGNS HAVE A 3/4"-16 THREADED HOLE FOR THE FRONT ROD END
- ★BOTH DESIGNS COME WITH THE 3/4" REAR ROD END & JAM NUT (EITHER WELDED OR THREADED IN), BUT NEITHER COMES WITH THE FRONT ROD END OR JAM NUT
- ★ARMS FEATURE DUAL 1/2" SHOCK MOUNTS & AN EXCLUSIVE SHOCK CLAMP BUSHING
- ★STRONG STEEL CONSTRUCTION
- ★LENGTHS ARE MEASURED FROM CENTER OF ROD END TO CENTER OF ROD END, SCREWED ALL THE WAY IN; WHEN MEASURING WITH ONLY ONE ROD END (AS THEY ARE SOLD), MEASURE FROM THE CENTER OF THE REAR ROD END TO THE FRONT END OF THE ARM & ADD 1 1/2"

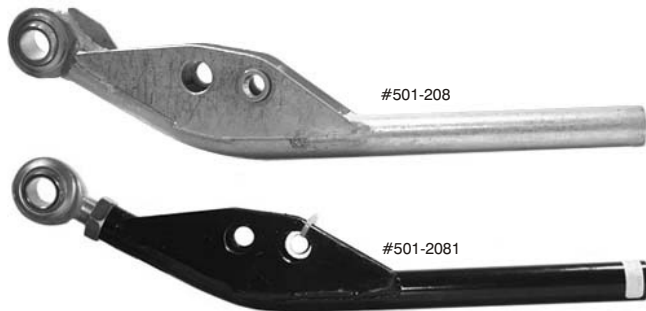

CENTER-TO-CENTER LENGTH	WELDED REAR	THREADED REAR
13 1/2"	-	501-2101
14"	501-208	501-2081
14 1/2"	-	501-2091
15"	501-206	501-2061
16 1/2"	-	501-2051
17"	501-204	501-2041
19 1/2"	-	501-2011
20 1/2"	501-200	501-2001

# SWING ARM & TRAILING ARM ADJUSTERS

- ★USED FOR QUICK, EASY ADJUSTMENT OF SWING ARMS OR TRAILING ARMS
- ★STEEL OR ALUMINUM
- ★5/8" OR 3/4" THREAD
- ★LEFT OR RIGHT THREAD



APPLICATION	BUILD	THREAD SIZE	MALE THREAD	FEMALE THREAD	PART #
SWING ARM	STEEL	3/4"	RIGHT	LEFT	501-003
TRAIL. ARM	STEEL	5/8"	RIGHT	LEFT	500-9999
TRAIL. ARM	STEEL	5/8"	LEFT	RIGHT	501-000
TRAIL. ARM	STEEL	3/4"	LEFT	RIGHT	501-002
TRAIL. ARM	ALUM.	5/8"	LEFT	RIGHT	500-999
TRAIL. ARM	ALUM.	3/4"	LEFT	RIGHT	501-001

\*#501-003 CAN ACTUALLY BE USED FOR SWING ARM OR TRAILING ARM

# SWING ARM FLOATERS

- ★DOUBLE SHEAR, 4 BAR Z-LINK FLOATERS WITH NO SHOCK MOUNTS; FIT 3" O.D. TUBES
- ★2" WIDE COLLARS; 3/4" THROUGH HOLES
- ★AVAILABLE IN STEEL & ALUMINUM; STEEL IS AVAILABLE WITH ROLLER BEARINGS



DESCRIPTION	STEEL	ALUM.
FLOATER	570-300	570-310
FLOATER W/ BEARINGS	570-3002	N/A

# PANHARD BAR MOUNTS ADJUSTABLE

- ★WELD-ON & CLAMP-ON MOUNTS AVAILABLE; BOTH FOR 3" O.D. TUBES
- ★MOUNTS MEASURE 6" FROM CENTER OF REAR END TUBE TO CENTER OF ROD END
- ★DOVE TAIL SLIDING DESIGN ALLOWS BAR TO BE ADJUSTED UP & DOWN
- ★ACCEPTS 3/4" ROD ENDS
- ★INCLUDES MOUNTING BOLT, SPACERS, & DOVE TAIL ADJUSTER

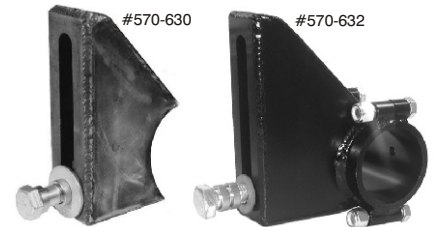

DESCRIPTION	PART #
WELD-ON MOUNT, ADJUSTABLE, 6"	570-630
CLAMP-ON MOUNT, ADJUSTABLE, 6"	570-632

# STANDARD CLAMP-ON

- ★AVAILABLE WITH SINGLE 4-BOLT CLAMP OR DUAL 2-BOLT CLAMPS
- ★MEASUREMENTS ARE FROM CENTER OF REAR END TUBE TO CENTER OF ROD END
- ★FIT 3" O.D. TUBES; ACCEPT 3/4" ROD ENDS



DESCRIPTION	PART #
SINGLE CLAMP-ON MOUNT, 5"	570-635
SINGLE CLAMP-ON MOUNT, 6"	570-636
DUAL CLAMP-ON MOUNT, 6"	570-637
DUAL CLAMP-ON MOUNT, 8"	570-638
DUAL CLAMP-ON MOUNT, 13"	570-643

Place your order at (479) 646-6988, Fax to (479) 646-5939, or visit [www.southwestspeed.com](http://www.southwestspeed.com)



# PINION MOUNTS - 9" FORD SINGLE SIDED - 4 POSITION

- ★MOUNTS PANHARD BAR (J-BAR) TO 9" FORD REAR END
- ★AVAILABLE IN STEEL OR ALUMINUM
- ★4 POSITIONS OF ADJUSTMENT WITH 3/4" THREADS
- ★WORKS THE SAME LEFT OR RIGHT



DESCRIPTION	PART #
9" FORD PINION, STEEL	570-580
9" FORD PINION, ALUMINUM	570-585

## DOUBLE SIDED

- ★MOUNTS PANHARD BAR (J-BAR) TO 9" FORD REAR END
- ★3 DIFFERENT STYLES AVAILABLE:
  - \*8 POSITIONS OF 3/4" THREADED HOLES,
  - \*SLOTTED WITH AN ADJUSTER WITH EVEN MORE POSITIONS, &
  - \*THREADED FOR FINE TUNING WITHOUT TAKING ANYTHING OFF THE CAR
- ★ALL MOUNTS ARE 1/2" STEEL, EXCEPT FOR THE #570-584, WHICH IS 3/4" POWDER COATED STEEL
- ★#570-5811 & #570-583 ARE "REVERSED", ALLOWING THE BAR TO BE MOUNTED LOWER

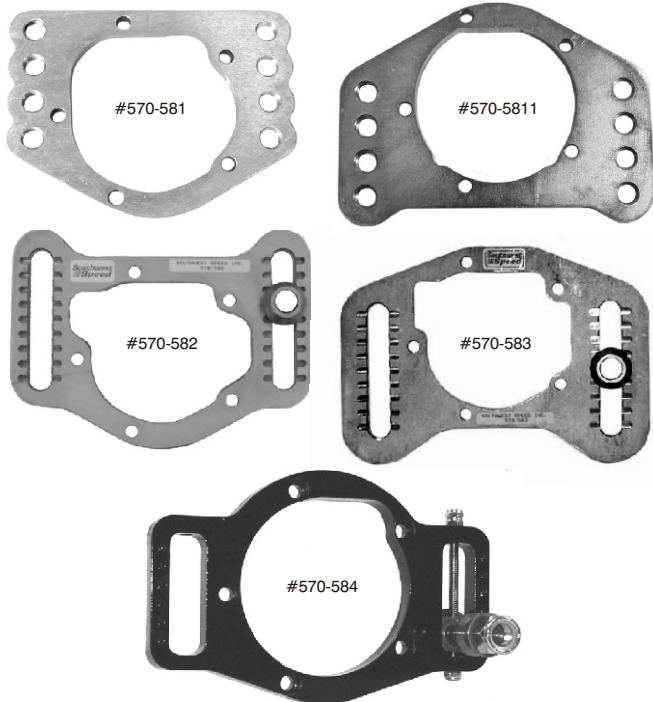

DESCRIPTION	PART #
8 POSITION MOUNT, STEEL	570-581
8 POSITION MOUNT, STEEL, REVERSED	570-5811
SLOTTED MOUNT, STEEL	570-582
SLOTTED MOUNT, STEEL, REVERSED	570-583
THREADED MOUNT, STEEL	570-584

\*REPLACEMENT ADJUSTER FOR SLOTTED MOUNTS: #570-5821

# PINION MOUNTS-QUICK CHANGE SINGLE SIDED

- ★MOUNTS PANHARD BARS TO QUICK CHANGES
- ★ALUMINUM STYLES AVAILABLE:
  - \*4 POSITIONS OF 3/4" THREADED HOLES (ECONOMY & PREMIUM) AND \*SLOTTED WITH AN ADJUSTER WITH EVEN MORE POSITIONS
- ★PREMIUM 4 POSITION & SLOTTED STYLES REPLACE PINION RETAINER & SEAL
- ★STEEL STYLES AVAILABLE:
  - 1 POSITION & 4 POSITIONS OF 3/4" HOLES

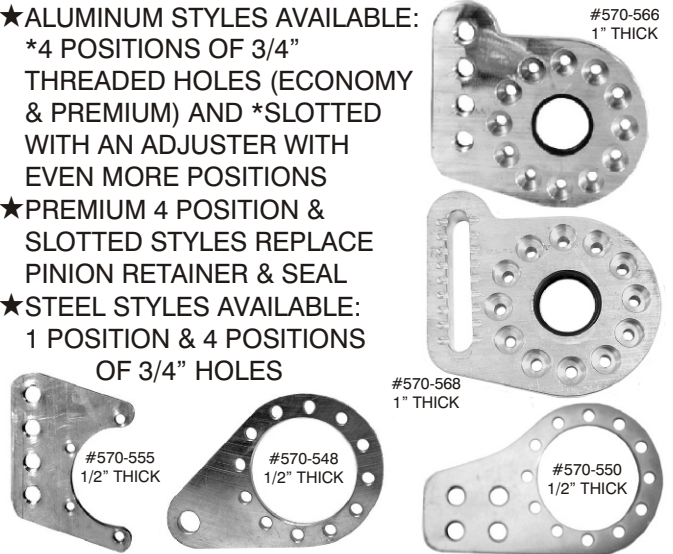

DESCRIPTION	PART #
ALUM. 4 POSITION MOUNT, ECONOMY	570-555
ALUM. 4 POSITION MOUNT, PREMIUM	570-566
ALUM. SLOTTED MOUNT, PREMIUM	570-568
STEEL 1 POSITION MOUNT	570-548
STEEL 4 POSITION MOUNT	570-550

\*REPLACEMENT ADJUSTER & O-RING FOR SLOTTED MOUNT: #570-5751

## DOUBLE SIDED

- ★STYLES AVAILABLE: \*8 POSITIONS OF 3/4" THREADED HOLES AND \*SLOTTED WITH AN ADJUSTER WITH EVEN MORE POSITIONS
- ★ECONOMY SLOTTED MOUNT USES EXISTING FRONT PINION RETAINER & SEAL
- ★PREMIUM SLOTTED AVAILABLE WITH SLOTS ON FRONT OR ON BACK FOR EXTRA STRENGTH & TO AVOID MUD GETTING PACKED IN SLOTS
- ★PREMIUM ALSO AVAILABLE IN A CLIMBING FORM FOR EASY ADJUSTMENT ON THE CAR



#570-576 1" THICK PICTURED FROM THE REAR

#570-5764 1" THICK

DESCRIPTION	PART #
8 POSITION MOUNT, ALUM.	570-573
SLOTTED MOUNT, ALUM., ECONOMY	570-553
SLOTTED MOUNT, ALUM.	570-575
SLOTTED MOUNT, ALUM., REAR SLOTS	570-576
SLOTTED MOUNT, ALUM., CLIMBING	570-5764

\*REPLACEMENT ADJUSTER & O-RING FOR SLOTTED MOUNTS: 570-5751

Place your order at (479) 646-6988, Fax to (479) 646-5939, or visit [www.southwestspeed.com](http://www.southwestspeed.com)

## 3RD LINK MOUNTS-9" FORD

- ★WELD-ON MOUNTS PUT TORQUE/3RD LINKS & UPPER "9010" SHOCKS ON 9" FORD REAR ENDS
- ★AVAILABLE WITH THE MOUNTING HOLES CENTERED DIRECTLY ON TOP OF THE HOUSING & WITH THE HOLES OFFSET TO THE BACK OF THE HOUSING
- ★EACH STYLE COMES IN THE STANDARD LONG TAIL VERSION, AS WELL AS A SHORTER TAIL VERSION TO ENSURE WE HAVE A BRACKET SET TO FIT YOUR REAR END
- ★3/16" THICK STEEL MOUNTS ARE SOLD AS 2 PIECE KITS, FEATURE A 1/2" SHOCK MOUNT BORE, & ARE AVAILABLE WITH EITHER 3/4" OR 1" BORES ON THE THROUGH HOLES

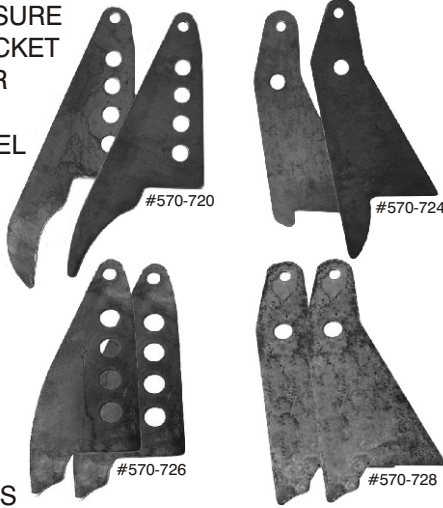

DESCRIPTION	PART #
KIT, CENTERED 3/4" HOLES	570-720
KIT, CENTERED 1" HOLES	570-721
KIT, CENTERED 3/4" HOLES, SHORT TAIL	570-726
KIT, CENTERED 1" HOLES, SHORT TAIL	570-727
KIT, OFFSET 3/4" HOLE	570-724
KIT, OFFSET 1" HOLE	570-725
KIT, OFFSET 3/4" HOLE, SHORT TAIL	570-728
KIT, OFFSET 1" HOLE, SHORT TAIL	570-729

## UPPER SHOCK MOUNTS FOR QUICK CHANGES

- ★LIGHTWEIGHT ALUMINUM BRACKETS MOUNT UPPER "9010" SHOCKS
- ★FEATURE 3 POSITIONS OF 1/2" THROUGH HOLES
- ★PRICED & SOLD INDIVIDUALLY



DESCRIPTION	PART #
Q.C. SHOCK MOUNT, 3 POSITION	570-675
Q.C. SHOCK MOUNT, 3 POSITION*	570-676

\*#570-676 ALSO HAS A 5/8" THROUGH HOLE ON THE BOTTOM

## UPPER SHOCK PIN & SPACER



PART #570-670

- ★EASY PULL HAIR PIN FOR QUICK SHOCK CHANGES
- ★BUILT-ON SPACER PUTS SHOCK IN THE RIGHT LOCATION

## 3RD LINK MOUNTS-QUICK CHANGE

- ★BOLT-ON MOUNTS PUT TORQUE/3RD LINKS & UPPER "9010" SHOCKS ON QUICK CHANGE REAR ENDS
- ★KITS COME WITH 2 BRACKETS & ALL NECESSARY HARDWARE, INCLUDING BOLTS, SPACERS, & LOCK NUTS
- ★3/4" 3RD LINK BOLTS; AVAILABLE WITH 1, 2, 3, 4, OR 5 POSITIONS OF ADJUSTMENT
- ★1/2" SHOCK MOUNTS W/ BOLTS
- ★AVAILABLE IN STEEL & ALUMINUM



DESCRIPTION	PART #
STEEL KIT, SHORT, 1 POS. 3/4" HOLES	570-700*
STEEL KIT, MEDIUM, 2 POS. 3/4" HOLES	570-703
STEEL KIT, MEDIUM, 3 POS. 3/4" HOLES	570-7071
STEEL KIT, TALL, 3 POS. 3/4" HOLES	570-7073
STEEL KIT, MULTI, 4 POS. 3/4" HOLES	570-7032
STEEL KIT, MULTI, 5 POS. 3/4" HOLES	570-7036
ALUM. KIT, SHORT, 1 POS. 3/4" HOLES	570-702*
ALUM. KIT, MEDIUM, 2 POS. 3/4" HOLES	570-704
STEEL PLATE ONLY, SHORT 1 POS. 3/4"	570-710*
STEEL PLATE ONLY, MEDIUM 2 POS. 3/4"	570-713
STEEL PLATE ONLY, MEDIUM 3 POS. 3/4"	570-7171
STEEL PLATE ONLY, TALL 3 POS. 3/4"	570-7173
STEEL PLATE ONLY, MULTI 4 POS. 3/4"	570-7132
STEEL PLATE ONLY, MULTI 5 POS. 3/4"	570-7136
ALUM. PLATE ONLY, SHORT 1 POS. 3/4"	570-712*
ALUM. PLATE ONLY, MEDIUM 2 POS. 3/4"	570-714
STAMPED STEEL PLATE ONLY, MED. 2 - 1"	570-716*
STAMPED ALUM. PLATE ONLY, MED. 2 - 1"	570-717*

\*THE SHORT MOUNTS & THE STAMPED MOUNTS WITH 1" HOLES DON'T HAVE A SHOCK MOUNT  
NOTE: WE ARE ALWAYS DEVELOPING NEW QUICK CHANGE MOUNTS; CHECK THEM OUT AT WWW.SOUTHWESTSPEED.COM

## TRAILING ARM TABS

- ★1 & 2 POSITION MOUNTS ARE NOTCHED TO FIT 3" & 3 1/2" O.D. REAR END TUBES
- ★3/16" THICK STEEL WITH 5/8" OR 3/4" I.D. HOLES
- ★COMMONLY USED TO FABRICATE FLOATERS
- ★SOLD INDIVIDUALLY

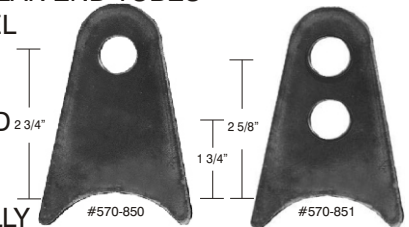

DESCRIPTION	PART #
1 POSITION TAB, 5/8" HOLE	570-850
2 POSITION TAB, 3/4" HOLES	570-851

Place your order at (479) 646-6988, Fax to (479) 646-5939, or visit [www.southwestspeed.com](http://www.southwestspeed.com)



# TRAILING ARM MOUNTS SINGLE SHOCK, SINGLE SHEAR

- ★1/2" THICK STEEL
- ★FITS 3" DIAMETER TUBES
- ★1/2" SHOCK MOUNT HOLE
- ★TWO 3/4" THREADED HOLES



DESCRIPTION	LEFT	RIGHT
WELD-ON MOUNT	570-002	570-004
CLAMP-ON MOUNT	570-006	570-008

# SINGLE SHOCK, DOUBLE SHEAR

- ★DOUBLE SHEAR, 3/16" THICK STEEL
- ★FITS 3" DIAMETER TUBES
- ★SINGLE, 1/2" SHOCK MOUNT HOLE
- ★THREE 3/4" THROUGH HOLES
- ★SAME LEFT & RIGHT



DESCRIPTION	PART #
WELD-ON MOUNT	570-030
CLAMP-ON MOUNT	570-031

# SINGLE SHOCK WITH SPRING CUP

- ★SINGLE SHEAR, 1/2" THICK STEEL
- ★FITS 3" DIAMETER TUBES
- ★SINGLE, 1/2" SHOCK MOUNT HOLE
- ★TWO 3/4" THREADED HOLES



DESCRIPTION	LEFT	RIGHT
WELD-ON MOUNT	570-012	570-014
CLAMP-ON MOUNT	570-016	570-018

# SINGLE SHOCK, TALL, WITH SPRING CUP

- ★SINGLE SHEAR, 1/2" THICK STEEL
- ★RAISES SPRING CUP UP 3" & LOWERS SHOCK MOUNT 2 1/2"
- ★FITS 3" DIAMETER TUBES
- ★SINGLE, 1/2" SHOCK MOUNT HOLE
- ★TWO 3/4" THREADED HOLES

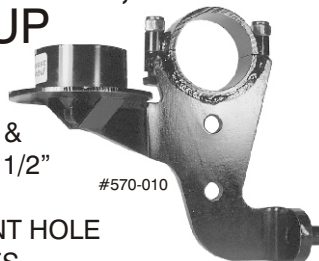

DESCRIPTION	PART #
CLAMP-ON MOUNT, LEFT	570-010
CLAMP-ON MOUNT, RIGHT	570-011

YOU CAN FIND THE TRAILING ARMS (OR SWEDGED TUBES) ON PAGE 50 & THE ROD ENDS & JAM NUTS ON PAGE 51

# TRAILING ARM MOUNTS DOUBLE SHOCK



- ★SINGLE SHEAR, 1/2" THICK STEEL
- ★FITS 3" DIAMETER TUBES
- ★DUAL 1/2" SHOCK MOUNT HOLES FOR MOUNTING SHOCKS & COILOVER ELIMINATORS
- ★SINGLE, 3/4" THREADED HOLE
- ★2 STYLES OF CLAMP-ON AVAILABLE

DESCRIPTION	PART #
WELD-ON MOUNT	570-032
CLAMP-ON MOUNT	570-033
CLAMP-ON MOUNT	570-034

# RUBBER BUSHING MOUNTS

- ★CAN BE USED TO MOUNT TRAILING ARM WITH A 3/4" ROD END OR WITH A RUBBER MOUNTED SYSTEM FOR EXTRA FLEX
- ★2 HOLES IN THE MOUNT ALLOW YOU TO MOVE THE ARM UP CLOSER TO OR DOWN FARTHER AWAY FROM THE REAR END
- ★FITS 3" DIAMETER TUBES
- ★1/2" SHOCK MOUNT HOLES

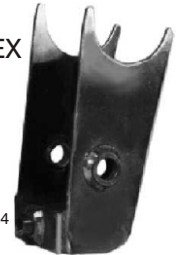

DESCRIPTION	LEFT	RIGHT
WELD-ON MOUNT	570-022	570-024
CLAMP-ON MOUNT	570-026	570-028

# STOCK GM METRIC MOUNTS

- ★MOUNTS STOCK TRAILING ARMS TO 9" FORD REAR ENDS
- ★MOUNTED LEFT & RIGHT WITH JUST ENOUGH ANGLE SO ALL STOCK PARTS WILL LINE UP
- ★UPPER MOUNTS COME WITH STOCK RUBBER BUSHINGS



DESCRIPTION	LEFT	RIGHT
WELD-ON MOUNT, UPPER	570-086	570-088
WELD-ON MOUNT, LOWER	570-046	570-048
TRAILING ARM BUSHINGS ONLY		PART #
SOLID STEEL BUSHING		101-7938
NYLON BUSHING		101-7939
STOCK RUBBER BUSHING		101-794
ADJUSTABLE RUBBER BUSHING, RED*		101-7941
ADJUSTABLE RUBBER BUSH., BLACK*		101-7942

\*ADJUSTABLE BUSHINGS FEATURE A SCREW-TOGETHER STEEL OUTER CASE WITH A REPLACEABLE RUBBER INNER BUSHING THAT CAN BE CHANGED TO EITHER A MEDIUM 70 (RED) OR A HARD 88 (BLACK) BUSHING TO ALLOW FOR REAR STEER

Place your order at (479) 646-6988, Fax to (479) 646-5939, or visit [www.southwestspeed.com](http://www.southwestspeed.com)



# CLAMP-ON SHOCK MOUNTS STEEL

- ★ BRACKETS MOUNT SHOCKS TO 3" O.D. REAR END TUBES
- ★ AVAILABLE WITH OR WITHOUT DOUBLE SHEAR, SWING ARM MOUNT
- ★ FEATURES SINGLE, 1/2" SHOCK MOUNT HOLE
- ★ NON-FLEXING, LIGHTWEIGHT STEEL CONSTRUCTION
- ★ AVAILABLE WITH A 5" OR 7" DROP FROM THE CENTER OF THE TUBE TO THE CENTER OF THE SHOCK HOLE



DESCRIPTION	PART #
STEEL BRKT, 5" DROP	570-100
STEEL BRKT, 7" DROP	570-102
STEEL BRKT WITH SWING ARM, 5" DROP	570-105
STEEL BRKT WITH SWING ARM, 7" DROP	570-107

# ALUMINUM

- ★ BRACKETS MOUNT SHOCKS TO 3" O.D. REAR END TUBES
- ★ FEATURES SINGLE, 1/2" SHOCK MOUNT HOLE
- ★ NON-FLEXING, LIGHTWEIGHT 6061 T-6 ALUMINUM CONSTRUCTION
- ★ AVAILABLE WITH A 5" OR 7" DROP FROM THE CENTER OF THE TUBE TO THE CENTER OF THE SHOCK HOLE, AS WELL AS IN AN ADJUSTABLE DESIGN THAT ALLOWS THE DROP TO BE SET AT 4", 5", 6", & 7"

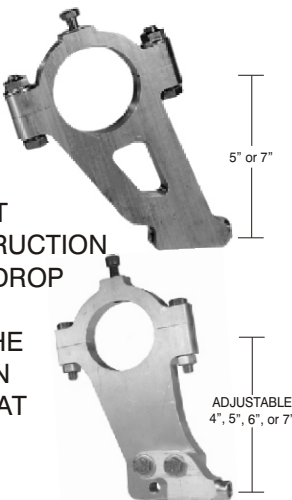

DESCRIPTION	PART #
ALUMINUM BRKT, 5" DROP	570-110
ALUMINUM BRKT, 7" DROP	570-112
ALUMINUM BRKT, ADJUSTABLE, 4" TO 7"	570-108

# STEEL CLAMP BRACKETS

- ★ LIGHTWEIGHT STEEL, 2 PIECE DESIGN
- ★ FEATURES HEX HEAD BOLTS & ONE 1/2"-13 THREADED MOUNTING HOLE



DESCRIPTION	PART #
BRACKET FOR 1 1/4" ROUND TUBE	800-3311
BRACKET FOR 1 1/2" ROUND TUBE	800-3313
BRACKET FOR 1 5/8" ROUND TUBE	800-3314
BRACKET FOR 1 3/4" ROUND TUBE	800-3315

\*1/2"-13 x 5" LONG MOUNTING STUD AVAILABLE, PART #800-349  
LEAD WEIGHT AVAILABLE IN 19 LB. BLOCKS (PART #800-350) WEIGHING 20 LBS. WITH MOUNTING BRACKETS & HARDWARE; 2 1/2" X 2 1/2" X 8"

# UNIVERSAL CLAMP COLLARS

- ★ UNIVERSAL COLLARS ENABLE YOU MOUNT SHOCKS, BARS, ETC. TO THE REAR END OR ALMOST ANY ROUND TUBING ON YOUR CAR
- ★ EASY TO WELD TO
- ★ AVAILABLE TO CLAMP TO 1 1/4", 1 1/2", 1 3/4", & 3" DIAMETER TUBES
- ★ 1/8" OR 1/4" THICK
- ★ 2 OR 4 BOLT CLAMPS



FITS ROUND TUBING	COLLAR WIDTH	THICK-NESS	CLAMP TYPE	PART #
3" O.D.	1 1/2"	1/4"	2 BOLT	570-200
3" O.D.	2 1/4"	1/8"	2 BOLT	570-201
3" O.D.	2 1/4"	1/4"	2 BOLT	570-202
3" O.D.	2 1/4"	1/4"	4 BOLT	570-2021
3" O.D.	3"	1/8"	4 BOLT	570-203
3" O.D.	3"	1/4"	4 BOLT	570-204
1 1/4" O.D.	2"	1/8"	2 BOLT	570-168
1 1/2" O.D.	2"	1/8"	2 BOLT	570-170
1 3/4" O.D.	2"	1/8"	2 BOLT	570-172

# ALUMINUM CLAMP BRACKETS

- ★ LIGHTWEIGHT 7075 T-6 ALUMINUM, 2 PIECE DESIGN
- ★ DESIGNED TO MOUNT NUMEROUS PARTS TO ROUND, SQUARE, OR RECTANGULAR TUBING ON THE CHASSIS
- ★ TWO 1/2"-13 THREADED MOUNTING HOLES
- ★ AVAILABLE IN 2 DIFFERENT DESIGNS; ONE WITH ALLEN HEAD BOLTS & ONE WITH HEX HEAD BOLTS

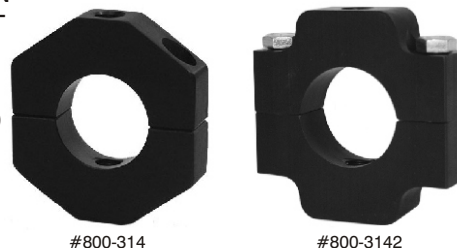

MOUNTS TO:	ALLEN HEAD HEX HEAD	
	DESIGN	DESIGN
1" ROUND TUBE	800-310	800-3102
1 1/8" ROUND TUBE	800-311	800-3112
1 1/4" ROUND TUBE	800-312	800-3122
1 3/8" ROUND TUBE	800-313	800-3132
1 1/2" ROUND TUBE	800-314	800-3142
1 5/8" ROUND TUBE	800-315	800-3152
1 3/4" ROUND TUBE	800-316	800-3162
2" ROUND TUBE	800-318	800-3182
1" SQUARE TUBE	800-319	800-3192
1 1/2" SQUARE TUBE	800-320	800-3202
2" SQUARE TUBE	800-326	800-3262
2" x 3" RECTANGLE TUBE	800-330	800-3302

\*1/2"-13 x 5" LONG MOUNTING STUD AVAILABLE, PART #800-349

Place your order at (479) 646-6988, Fax to (479) 646-5939, or visit [www.southwestspeed.com](http://www.southwestspeed.com)

# SOUTHWEST SPEED U-DESIGN-IT FLOATERS

- ★NOW YOU CAN DESIGN & WELD YOUR OWN FLOATER, ALLOWING YOU TO POSITION ALL THE MOUNTS WHERE THEY WORK BEST ON YOUR CAR
- ★THE TUBES COME WITH EITHER TEFLON LINERS OR ROLLER BEARINGS & FIT 3" O.D. REAR ENDS
- ★SOLD IN INDIVIDUAL PIECES
- ★UPPER & LOWER BRACKETS ARE 1/2" THICK; EACH ONE FEATURES A 1/2" LOCK HOLE & 5/8" THROUGH HOLES
- ★THESE 1/2" BRACKETS ARE DESIGNED TO GIVE YOU 9" CENTER-TO-CENTER BETWEEN THE UPPER & LOWER THROUGH HOLES AND 6" C-TO-C BETWEEN THE LOCK HOLES

#569-9003



#569-9004



#569-8962



HERE IS AN EXAMPLE OF THE FLOATERS THAT CAN BE BUILT

#569-8963



#569-9029



#569-9006

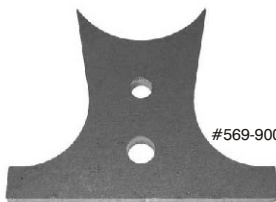

#570-851



DESCRIPTION	PART #
FLOATER TUBE W/ BEARINGS, 1.5" WIDE	569-8955
FLOATER TUBE WITH BEARINGS, 3" WIDE	569-8959
FLOATER TUBE WITH BEARINGS, 4" WIDE	569-8961
FLOATER TUBE WITH LINER, 5" WIDE	569-8962
FLOATER TUBE WITH BEARINGS, 5" WIDE	569-8963
UPPER/LOWER FLOATER BRACKET	569-9003
UPPER/LOWER FLOATER BKT, 1" TALLER	569-9002
UPPER FLOATER BRACKET, 3 POSITION	569-9005
UPPER FLOATER BRACKET, 4 POSITION	569-9004
LOWER FLOATER BRACKET, DUAL	569-9006
LOWER FLOATER BKT, DUAL, 2 HOLE	569-9007
3/16" THICK BRACKET*, ONE 5/8" HOLE	570-850
3/16" THICK BRACKET*, TWO 3/4" HOLES	570-851
SHOCK MOUNT TUBE, 1/2" x 2 3/4" WIDE	569-9029
*USE TWO 3/16" BRACKETS TO MAKE A DOUBLE SHEAR MOUNT	

WE ARE ALWAYS DEVELOPING NEW PARTS FOR THE U-DESIGN-IT FLOATERS; CHECK WWW.SOUTHWESTSPEED.COM TO SEE WHAT'S NEW

# FLOATERS, 2 BAR

- ★LIGHTWEIGHT STEEL
- ★FIT 3" O.D. TUBES
- ★AVAILABLE IN A 5" WIDE SINGLE SHEAR DESIGN WITH A 3/4" THREADED HOLE & A 2" WIDE DOUBLE SHEAR DESIGN WITH EITHER 5/8" OR 3/4" THROUGH HOLES

#570-210



DESCRIPTION	PART #
2 BAR FLOATER, 5" WIDE, 3/4"-16 HOLE	570-209
2 BAR FLOATER, 2" WIDE, 5/8" HOLES	570-210
2 BAR FLOATER, 2" WIDE, 3/4" HOLES	570-211

# FLOATERS, 4 BAR WITH NO SHOCK MOUNT SINGLE SHEAR, LOCKABLE

- ★CAN BE LOCKED WITH COLLAR #570-240 OR #570-250 (PAGE 216)
- ★CAN BE USED WITH ALL LOCKABLE SHOCK MOUNTS
- ★FIT 3" O.D. TUBES
- ★5/8" THREADED HOLES
- ★3" WIDE COLLAR
- ★CAN BE USED WITH MANY OTHER FLOATER KITS

#570-290



DESCRIPTION	STEEL	ALUMINUM
4 BAR FLOATER, 3" WIDE	570-280	570-290

# DOUBLE SHEAR / Z-LINK / SWING ARM

- ★DOUBLE SHEAR, 4 BAR Z-LINK FLOATERS WITH NO SHOCK MOUNTS
- ★FIT 3" O.D. TUBES
- ★3/4" THROUGH HOLES
- ★2" WIDE COLLAR
- ★AVAILABLE IN STEEL & ALUMINUM; STEEL IS AVAILABLE WITH ROLLER BEARINGS



DESCRIPTION	STEEL	ALUM.
4 BAR FLOATER	570-300	570-310
4 BAR FLOATER W/ BEARINGS	570-3002	N/A

NOTE: FOR A CONSTANT STREAM OF NEW PRODUCTS & UP-TO-THE-SECOND PRICING, VISIT WWW.SOUTHWESTSPEED.COM

Place your order at (479) 646-6988, Fax to (479) 646-5939, or visit [www.southwestspeed.com](http://www.southwestspeed.com)

# FLOATERS, 4 BAR WITH BRAKE BRACKET & NO SHOCK MOUNT

- ★FIT 3" O.D. TUBES
- ★5/8" TRAILING ARM HOLES
- ★5" WIDE
- ★SAME FOR THE LEFT & THE RIGHT
- ★GREAT FOR USE WITH CLAMP-ON SHOCK MOUNTS & OTHER FLOATERS

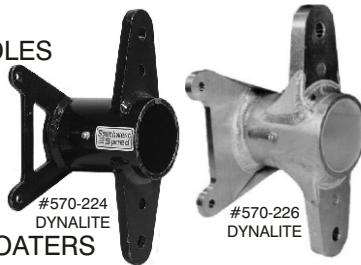

DESCRIPTION	STEEL	ALUM.
4 BAR, DYNALITE	570-224	570-226
4 BAR, SUPERLITE	570-228	570-230
4 BAR, BIG GM	570-232	570-234
4 BAR, METRIC GM	570-236	570-238
4 BAR, METRIC GM, BEARING	570-2362	-

\*#570-2362 USES ROLLER BEARINGS FOR SMOOTHER MOVEMENT

# FLOATERS, 4 BAR SINGLE SHOCK MOUNT

- ★FIT 3" O.D. TUBES
- ★5/8" TRAILING ARM HOLES & 1/2" SHOCK MOUNT
- ★AVAILABLE IN STANDARD & LOCKABLE DESIGNS
- ★BOTH DESIGNS COME IN STEEL WITH A FIXED SHOCK MOUNT AND IN ALUMINUM WITH A FIXED OR AN ADJUSTABLE MOUNT
- ★STANDARD FLOATERS HAVE 5" WIDE COLLARS & LOCKABLE FLOATERS HAVE 3" WIDE COLLARS
- ★FIXED MOUNTS HAVE A 5" DROP FROM CENTER OF REAR END TUBE TO CENTER OF SHOCK MOUNTS; ADJUSTABLE MOUNTS ENABLE THE DROP TO BE SET AT 5", 6", 7", OR 8"
- ★GREAT FOR USE W/ OTHER FLOATERS

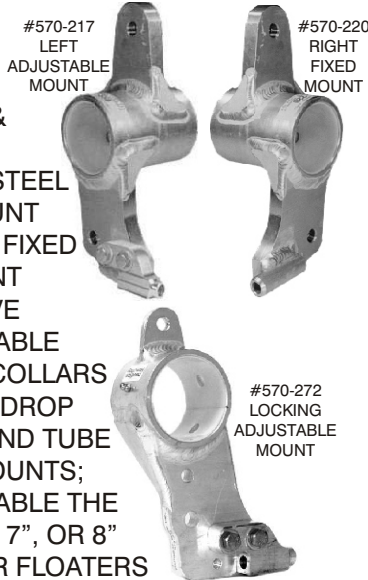

DESCRIPTION	LEFT	RIGHT	LOCKING
STEEL FIXED	570-214	570-216	570-260
ALUMINUM FIXED	570-218	570-220	570-270
ALUMINUM ADJUST.	570-217	570-219	570-272

\*THE LOCKING FLOATERS ARE THE SAME LEFT & RIGHT

# MODULAR, SINGLE SHOCK

- ★EXCLUSIVE ALUMINUM DESIGN ENABLES YOU TO LOCK OR UNLOCK 4 BAR AND/OR SHOCK
- ★FIT 3" O.D. TUBES
- ★5/8" TRAILING ARM HOLES
- ★COMES WITH TEFLON LINER
- ★GREAT FOR USE WITH CLAMP-ON BRAKE BRACKETS

**PART #570-937**

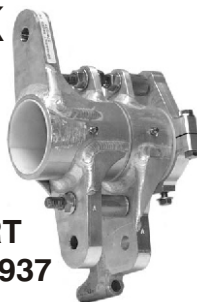

YOU CAN FIND THE TRAILING ARMS (OR SWEDGED TUBES) ON PAGE 50 & THE ROD ENDS & JAM NUTS ON PAGE 51

# FLOATERS, 4 BAR SINGLE SHOCK MOUNT WITH BRAKE BRACKET

- ★FIT 3" O.D. TUBES
- ★7" WIDE COLLARS, 5/8" TRAILING ARM HOLES, & 1/2" SHOCK MOUNT



- ★AVAILABLE IN STEEL WITH A FIXED SHOCK MOUNT AND IN ALUMINUM WITH A FIXED OR AN ADJUSTABLE MOUNT
- ★FIXED MOUNTS HAVE A 5" DROP FROM CENTER OF REAR END TUBE TO CENTER OF SHOCK MOUNTS, WHILE ADJUSTABLE MOUNTS ENABLE THE DROP TO BE SET AT 5", 6", 7", OR 8"



DESCRIPTION	STEEL	ALUM.
DYNALITE BRACKET, LEFT	570-344	570-346
DYNALITE BRACKET, RIGHT	570-348	570-350
DYNALITE BRKT., LEFT (ADJ.)	-	570-347
DYNALITE BRKT., RIGHT (ADJ.)	-	570-351
SUPERLITE BRACKET, LEFT	570-352	570-354
SUPERLITE BRACKET, RIGHT	570-356	570-358
SUPERLITE BRKT, LEFT (ADJ.)	-	570-355
SUPERLITE BRKT, RIGHT (ADJ.)	-	570-359
BIG GM BRACKET, LEFT	570-360	570-362
BIG GM BRACKET, RIGHT	570-364	570-366
GM METRIC BRACKET, LEFT	570-368	570-370
GM METRIC BRACKET, RIGHT	570-372	570-374
GM METRIC BRACKET, LEFT*	570-378*	-
GM METRIC BRACKET, RIGHT*	570-382*	-

\*ALTERNATE DESIGN GM METRIC FLOATERS WITH DOUBLE SHEAR MOUNTS WITH 3/4" THROUGH HOLES AND 8 1/4" WIDE COLLAR FOR THE LEFT & 6 3/4" WIDE COLLAR FOR THE RIGHT

# MODULAR, SINGLE SHOCK WITH BRAKE BRACKET

- ★EXCLUSIVE ALUMINUM DESIGN ENABLES YOU TO LOCK OR UNLOCK BRAKE, SHOCK, AND/OR 4 BAR ON THE LEFT SIDE
- ★FIT 3" O.D. TUBES
- ★COMES WITH TEFLON LINER
- ★5/8" TRAILING ARM HOLES & SINGLE, 1/2" ADJUSTABLE SHOCK MOUNT, ALLOWING THE DROP TO BE SET AT 5", 6", 7", OR 8"

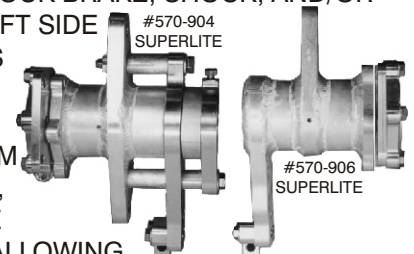

DESCRIPTION	LEFT	RIGHT
DYNALITE BRACKET, MOD.	570-900	570-902
SUPERLITE BRACKET, MOD.	570-904	570-906
BIG GM BRACKET, MOD.	570-908	570-910
GM METRIC BRACKET, MOD.	570-912	570-914

Place your order at (479) 646-6988, Fax to (479) 646-5939, or visit [www.southwestspeed.com](http://www.southwestspeed.com)



# FLOATERS, 4 BAR DUAL SHOCK MOUNTS DESIGN B

- ★FIT 3" O.D. TUBES
- ★SAME FOR LEFT & RIGHT
- ★5" WIDE COLLARS, 5/8" TRAILING ARM HOLES, & 1/2" SHOCK MOUNTS
- ★4 1/2" DROP FROM CENTER OF REAR END TUBE TO CENTER OF TRAILING ARM HOLES AND 5 1/2" DROP TO THE CENTER OF SHOCK MOUNT HOLES
- ★COME WITH EITHER A TEFLON LINER OR ROLLER BEARINGS



DESCRIPTION	STEEL	ALUM.
FLOATER W/ TEFLON LINER	570-321	570-331
FLOATER W/ BEARINGS	570-3212	-

# DESIGN C

- ★HIGH-CARBON STEEL
- ★FIT 3" O.D. TUBES
- ★SAME FOR LEFT & RIGHT
- ★5" WIDE COLLARS, 5/8" TRAILING ARM HOLES, & 1/2" SHOCK MOUNTS
- ★5 1/2" DROP FROM CENTER OF REAR END TUBE TO CENTER OF SHOCK MOUNT HOLES
- ★COMES WITH A TEFLON LINER

**PART  
#570-340**



# DESIGN A

- ★FIT 3" O.D. TUBES
- ★SAME FOR LEFT & RIGHT
- ★3" WIDE COLLARS, 3/4" TRAILING ARM HOLES, & 1/2" SHOCK MOUNTS
- ★SEVERAL DIFFERENT DROPS AVAILABLE; MEASURED FROM CENTER OF REAR END TUBE TO CENTER OF SHOCK MOUNT HOLES
- ★#570-320 HAS A 4 1/2" DROP
- ★#570-324 HAS A 7" DROP
- ★#570-330 FEATURES ADJUSTABLE MOUNTS THAT ENABLE THE DROP TO BE SET AT 5", 6", 7" OR 8"



DESCRIPTION	STEEL	ALUM.
4 BAR FLOATER	570-320	570-330
4 BAR FLOATER	570-324	-

# FLOATERS, 4 BAR DUAL SHOCK MOUNTS WITH 3 TOP POSITIONS

- ★FEATURES 3 TOP POSITIONS FOR EXTRA ADJUSTMENT OF THE UPPER TRAILING ARM
- ★HIGH CARBON STEEL CONSTRUCTION
- ★FIT 3" O.D. TUBES
- ★5" WIDE COLLARS, 5/8" TRAILING ARM HOLES, & 1/2" SHOCK MOUNTS
- ★7 1/2" DROP FROM CENTER OF REAR END TUBE TO CENTER OF SHOCK MOUNT HOLES
- ★FLOATERS COME WITH EITHER A TEFLON LINER OR ROLLER BEARINGS



DESCRIPTION	LEFT	RIGHT
FLOATER W/ TEFLON LINER	570-315	570-317
FLOATER W/ BEARINGS	570-3152	570-3172

# WITH ADJUSTABLE SHOCK MOUNTS

- ★LIGHTWEIGHT ALUMINUM
- ★FEATURES 2 TOP POSITIONS FOR EXTRA ADJUSTMENT OF THE UPPER TRAILING ARM
- ★FLOATERS COME WITH TEFLON LINER & FIT 3" O.D. TUBES
- ★5" WIDE COLLARS, 5/8" TRAILING ARM HOLES, & 1/2" ADJUSTABLE SHOCK MOUNTS THAT ENABLE THE DROP TO BE SET AT 5", 6", 7", & 8" FROM CENTER OF REAR END TUBE TO CENTER OF SHOCK MOUNT HOLES



DESCRIPTION	LEFT	RIGHT
FLOATER W/ ADJ. MOUNTS	570-221	570-222

#570-330 (AT THE BOTTOM LEFT) & #570-273 (AT THE BOTTOM RIGHT) ALSO HAVE DUAL ADJUSTABLE SHOCK MOUNTS

# LOCKABLE

- ★TOP TAB ALLOWS THESE FLOATERS TO BE LOCKED
- ★LIGHTWEIGHT ALUMINUM
- ★SAME LEFT & RIGHT
- ★FIT 3" O.D. TUBES
- ★3" WIDE COLLARS, 5/8" THROUGH HOLES, & 1/2" SHOCK MOUNTS
- ★FIXED SHOCK MOUNTS HAVE A 5" DROP FROM CENTER OF REAR END TUBE TO CENTER OF SHOCK MOUNTS, WHILE ADJUSTABLE MOUNTS ENABLE THE DROP TO BE SET AT 5" - 8" ON THE ONE SIDE AND 4"-9" ON THE OTHER



DESCRIPTION	FIXED	ADJUST.
LOCKABLE, 4 BAR FLOATER	570-271	570-273

Place your order at (479) 646-6988, Fax to (479) 646-5939, or visit [www.southwestspeed.com](http://www.southwestspeed.com)

# FLOATERS, 4 BAR DUAL SHOCK MOUNTS WITH BRAKE BRACKET

- ★LIGHTWEIGHT ALUMINUM
- ★FLOATERS COME WITH TEFLON LINER & FIT 3" O.D. TUBES
- ★7" WIDE COLLARS, 5/8" TRAILING ARM HOLES, & 1/2" SHOCK MOUNTS THAT ENABLE THE DROP TO BE SET AT 5", 6", 7", OR 8" FROM CENTER OF REAR END TUBE TO CENTER OF SHOCK MOUNTS

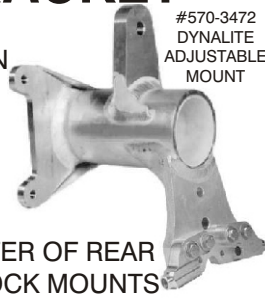

#570-3472  
DYNALITE  
ADJUSTABLE  
MOUNT

DESCRIPTION	LEFT	RIGHT
DYNALITE BRACKET	570-3472	570-3512
SUPERLITE BRACKET	570-3552	570-3592

# MODULAR, DUAL SHOCKS WITH BRAKE BRACKET

- ★EXCLUSIVE ALUMINUM DESIGN ENABLES YOU TO LOCK OR UNLOCK BRAKE, SHOCK, AND/OR 4 BAR ON LEFT SIDE
- ★COME WITH TEFLON LINER & FIT 3" O.D. TUBES
- ★5/8" TRAILING ARM HOLES & DUAL, 1/2" ADJUSTABLE SHOCK MOUNTS, ALLOWING THE DROP TO BE SET AT 5", 6", 7", OR 8"

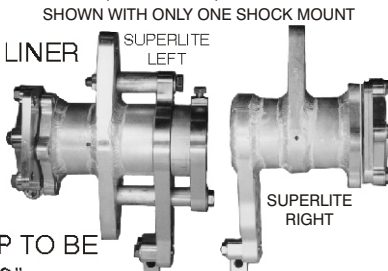

SHOWN WITH ONLY ONE SHOCK MOUNT

DESCRIPTION	LEFT	RIGHT
DYNALITE BRACKET, MOD.	570-901	570-903
SUPERLITE BRACKET, MOD.	570-905	570-907

# BRAKE FLOATERS

- ★FIT 3" O.D. TUBES
- ★DUAL ADJUSTMENTS
- ★ISOLATES BRAKE FORCES
- ★AVAILABLE WITH 5/8" & 3/4" THROUGH HOLES
- ★NOW AVAILABLE WITH ROLLER BEARINGS

#570-4182  
LEFT HAND  
GM METRIC  
WITH BEARINGS



BRACKET	SIDE	HOLES	STEEL	ALUM.
GM METRIC	LEFT	5/8"	570-417	-
GM METRIC*	LEFT	5/8"	570-4172	-
GM METRIC	LEFT	3/4"	570-418	570-420
GM METRIC*	LEFT	3/4"	570-4182	-
GM METRIC	RIGHT	5/8"	570-421	-
GM METRIC*	RIGHT	5/8"	570-4212	-
GM METRIC	RIGHT	3/4"	570-422	570-424
GM METRIC*	RIGHT	3/4"	570-4222	-
BIG GM	LEFT	3/4"	570-410	570-412
BIG GM	RIGHT	3/4"	570-414	570-416
DYNALITE	LEFT	3/4"	570-394	570-396
DYNALITE	RIGHT	3/4"	570-398	570-400
SUPERLITE	LEFT	3/4"	570-402	570-404
SUPERLITE	RIGHT	3/4"	570-406	570-408

\*DENOTES THE BRAKE FLOATERS WITH BEARINGS

# FLOATERS, 4 BAR WITH 3 TOP POSITIONS & BRAKE BRACKET, BOTH SINGLE & DUAL SHOCK

- ★FEATURES 3 TOP POSITIONS FOR EXTRA ADJUSTMENT OF THE UPPER TRAILING ARM
- ★FLOATERS COME WITH TEFLON LINER & FIT 3" O.D. TUBES
- ★5/8" TRAILING ARM HOLES & EITHER SINGLE OR DUAL, 1/2" ADJUSTABLE SHOCK MOUNTS, ALLOWING THE DROP TO BE SET AT 5", 6", 7", OR 8"

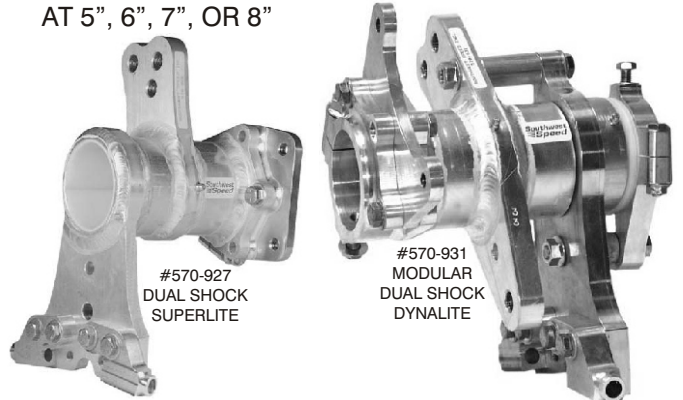

#570-927  
DUAL SHOCK  
SUPERLITE

#570-931  
MODULAR  
DUAL SHOCK  
DYNALITE

DESCRIPTION	LEFT	RIGHT
SINGLE SHOCK, DYNALITE	-	570-929
SINGLE SHOCK, SUPERLITE	-	570-926
DUAL SHOCK, DYNALITE	570-928	570-930
DUAL SHOCK, SUPERLITE	570-925	570-927
DUAL, DYNALITE, MODULAR*	570-931*	-

\*MODULAR DESIGN THAT ENABLES YOU TO LOCK OR UNLOCK THE BRAKE, SHOCKS, AND/OR 4 BAR

# SWIVELING SHOCK MOUNT

- ★EXCLUSIVELY DESIGNED SHOCK MOUNT BOLTS TO ANY EXISTING FLOATER SHOCK MOUNT ENABLING THE SHOCK TO SWIVEL

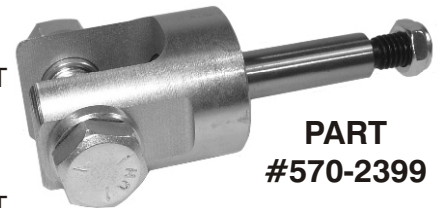

PART  
#570-2399

# FLOATER ROLLER BEARINGS



- ★ROLLER BEARINGS TO FIT IN FLOATERS TO ALLOW SMOOTHER MOVEMENT WITH LESS BIND
- ★FIT 3" O.D. TUBES

DESCRIPTION	PART #
FLOATER ROLLER BEARING, 3.002" I.D.	570-950
FLOATER ROLLER BEARING, 3.004" I.D.	570-952
FLOATER ROLLER BEARING, 3.007" I.D.	570-955
FLOATER ROLLER BEARING, 3.008" I.D.	570-956
FLOATER ROLLER BEARING, 3.012" I.D.	570-959

Place your order at (479) 646-6988, Fax to (479) 646-5939, or visit [www.southwestspeed.com](http://www.southwestspeed.com)

# FLOATER LOCKS

- ★LOCKS FLOATERS & SHOCK MOUNTS
- ★FIT 3" O.D. TUBES
- ★1/2" BOLT HOLES
- ★AVAILABLE IN STEEL & ALUMINUM

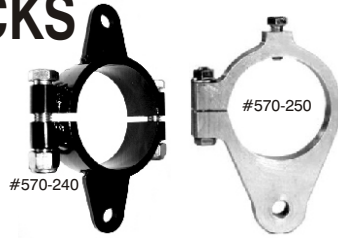

DESCRIPTION	PART #
FLOATER LOCK, STEEL, 1 1/2" WIDE	570-240
FLOATER LOCK, ALUMINUM, 3/4" WIDE	570-250
BOLT, NUT, & SPACER KIT	570-251

# RETAINER RINGS

- ★KEEPS FLOATERS IN PLACE
- ★WELD-ON & BOLT-ON AVAILABLE



DESCRIPTION	PART #
WELD-ON, STEEL, 1/4" THICK, 1/8" WIDE	570-478
BOLT-ON, STEEL, 1/8" THICK, 1/2" WIDE	570-480
BOLT-ON, STEEL, 1/4" THICK, 5/8" WIDE	570-482
BOLT-ON, ALUM, 5/16" THICK, 5/8" WIDE	570-485

# TEFLON / NITRILE FLOATER LINERS

- ★LINERS PROTECT REAR END TUBES & FLOATERS FROM GALLING
- ★STAGGERED LUBRICATION HOLES GIVE BETTER GREASE DISTRIBUTION
- ★TEFLON RING FOR THE END OF THE FLOATER TUBES ALSO AVAILABLE

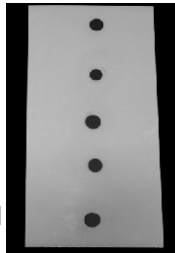

DESCRIPTION	PART #
TEFLON LINER, 2 1/4" WIDE	570-252
TEFLON LINER, 5" WIDE	570-254
TEFLON LINER, 7" WIDE	570-256
TEFLON END RING FOR 3" O.D. TUBES	570-259

# FRAME MOUNTS-WELD-ON 4 BAR RADIUS ROD BRACKETS

- ★EXCLUSIVE DESIGN BRACKETS MOUNT BOTH THE UPPER & LOWER TRAILING ARMS & GIVE 7 HOLES OF RADIUS ADJUSTMENT
- ★TAKES 2 TO MOUNT THE ARMS IN DOUBLE SHEAR FASHION
- ★PRICED & SOLD INDIVIDUALLY



DESCRIPTION	THICKNESS	
	1/8"	3/16"
4 BAR RADIUS BRKT.	570-4625	570-4626

\*SEVERAL OTHER DESIGNS OF SIMILAR 4 BAR BRACKETS WILL BE AVAILABLE; CHECK [www.southwestspeed.com](http://www.southwestspeed.com)

# ANGLED RADIUS ROD BRACKET

- ★6 POSITIONS OF 5/8"-18 THREADED HOLES
- ★1/4" THICK
- ★PRICED & SOLD INDIVIDUALLY

PART #570-441



# FRAME MOUNTS-WELD-ON RADIUS ROD BRACKETS, FLAT

- ★FLAT BRACKETS WITH RADIUS THROUGH HOLES
- ★TAKES 2 TO MOUNT A ROD END
- ★PRICED & SOLD INDIVIDUALLY
- ★AVAILABLE IN 1/8" & 3/16" THICK STEEL



DESCRIPTION	HOLE SIZE	THICKNESS	
		1/8"	3/16"
5 HOLE MOUNT	5/8"	570-456	570-4563
5 HOLE MOUNT	3/4"	570-458	570-4583
6 HOLE MOUNT	5/8"	570-460	570-4603
6 HOLE MOUNT	3/4"	570-462	570-4623

# RADIUS ROD BRACKETS, NOTCHED FOR SQUARE TUBING

- ★NOTCHED BRACKETS WITH RADIUS HOLES
- ★#570-465 HAS A STRAIGHT, 3/4" SLOT
- ★TAKES 2 TO MOUNT A ROD END
- ★PRICED & SOLD INDIVIDUALLY



DESCRIPTION	HOLE SIZE	THICKNESS	
		1/8"	3/16"
NOTCHED 3 HOLE MOUNT	1/2"	570-450	570-4503
NOTCHED 3 HOLE MOUNT	5/8"	570-451	570-4513
NOTCHED 4 HOLE MOUNT	1/2"	570-453	570-4533
NOTCHED 4 HOLE MOUNT	5/8"	570-454	570-4543
NOTCHED 4 HOLE MOUNT	3/4"	570-455	570-4553

\*NOTCHED, 1/4" THICK MOUNT WITH 3/4" SLOT = PART #570-465

# 90/10 SHOCK MOUNT, NOTCHED FOR 1 1/2" ROUND TUBING

- ★FOUR 1/2" THROUGH HOLES
- ★PRICED & SOLD INDIVIDUALLY



DESCRIPTION	THICKNESS	
	1/8"	3/16"
NOTCHED 4 HOLE MT.	570-447	570-4473

# DOUBLE SHEAR FLAT BRACKETS

- ★EXCLUSIVE 3 PIECE DESIGN AVAILABLE IN 3 OR 6 POSITION
- ★FLAT MOUNT WELDS TO CHASSIS

DESCRIPTION	THROUGH HOLE SIZE	
	5/8"	3/4"
3 POSITION MOUNT	570-510	570-512
6 POSITION MOUNT	570-520	570-522

#570-520

# SLOTTED SLIDING MOUNTS

- ★SLIDING MOUNTS WITH 3/4" SLOTS
- ★ALLOWS FOR SMOOTH, PRECISE UP & DOWN ADJUSTMENT

DESCRIPTION	THICKNESS	
	1/8"	3/16"
3/4" SLIDING MOUNT	570-506	570-507

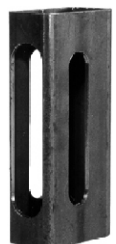

Place your order at (479) 646-6988, Fax to (479) 646-5939, or visit [www.southwestspeed.com](http://www.southwestspeed.com)



# FRAME MOUNTS-CLAMP-ON FOR SQUARE TUBING SINGLE MOUNT

- ★SLIDING, 2 PIECE, CLAMP-ON DESIGN IN BOTH STEEL & ALUMINUM IS EASILY ADJUSTABLE
- ★SINGLE, 3/4" MOUNTING HOLE

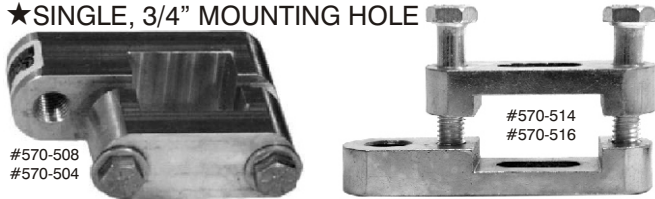

DESCRIPTION	STEEL	ALUM.
FOR 1 1/2" SQUARE TUBING	570-514	570-508
FOR 2" SQUARE TUBING	570-516	570-504

# DUAL MOUNTS

- ★SLIDING, 2 PIECE, CLAMP-ON DESIGN IN BOTH STEEL & ALUMINUM IS EASILY ADJUSTABLE
- ★DUAL, 3/4" MOUNTING HOLES

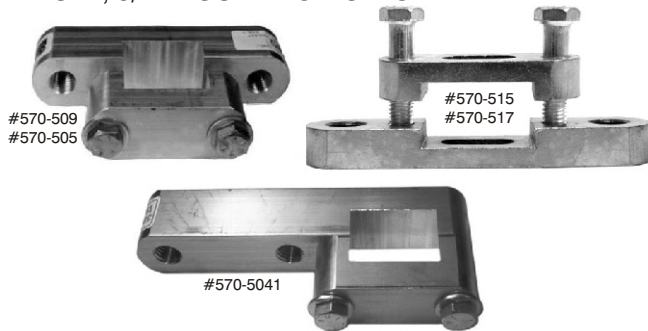

DESCRIPTION	STEEL	ALUM.
FOR 1 1/2" SQUARE TUBING	570-515	570-509
FOR 2" SQUARE TUBING	570-517	570-505
FOR 2" SQUARE TUBING*	-	570-5041

\*#570-5041 HAS BOTH MOUNTING HOLES ON ONE SIDE, GIVING AN EXTRA 3" OF MOUNTING LENGTH

# DUAL MOUNTS, RADIUSED

- ★EXCLUSIVE, SLIDING, 2 PIECE MOUNTS IN BOTH STEEL & ALUMINUM ARE EASILY ADJUSTABLE
- ★CUSTOM DESIGNED ARC SLOTS ALLOW FOR ADJUSTMENT UP & DOWN ON A RADIUS
- ★ADJUSTERS HAVE 3/4" MOUNTING HOLES
- ★#570-5054 HAS A CLIMBING FEATURE, WHICH MAKES IT EVEN EASIER TO ADJUST ON THE CAR



DESCRIPTION	PART #
STEEL RADIUS MOUNT, 1 1/2" TUBING	570-5152
STEEL RADIUS MOUNT, 2" TUBING	570-5172
ALUM. CLIMBING RADIUS MOUNT, 2"	570-5054

# FRAME MOUNTS-CLAMP-ON FOR SQUARE TUBING SINGLE MOUNT, CENTERED

- ★STEEL FRAME MOUNTS WITH A SINGLE MOUNT, CENTERED UP ON THE TUBING
- ★SLIDING, 2 PC. DESIGNS ARE EASILY ADJUSTED
- ★#570-5141 & #570-5161 ARE USED WITH 3/4" ROD ENDS
- ★#570-494 & #570-499 FEATURE A DOUBLE SHEAR MOUNT THAT ACCEPTS 5/8" & 3/4" ROD ENDS
- ★#570-513 FEATURES A DOUBLE SHEAR MOUNT THAT ACCEPTS 3/4" ROD ENDS & IS PRIMARILY USED WITH TORQUE LINKS

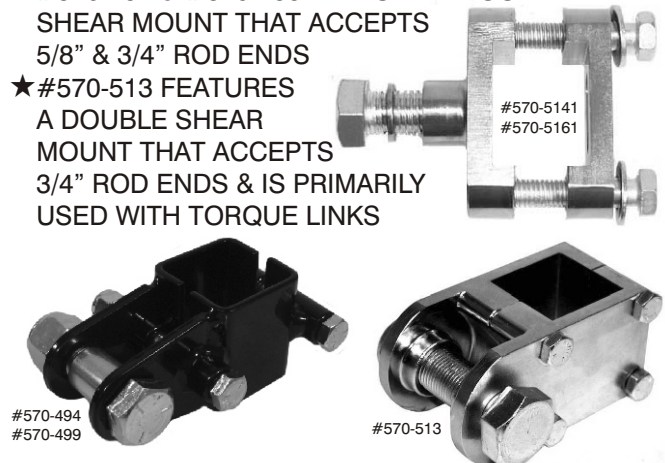

DESCRIPTION	PART #
SINGLE SHEAR FOR 1 1/2" TUBING	570-5141
SINGLE SHEAR FOR 2" TUBING	570-5161
DOUBLE SHEAR FOR 1 1/2" TUBING	570-494
DOUBLE SHEAR FOR 2" TUBING	570-499
DOUBLE SHEAR FOR 1 1/2" TUBING, T.L.	570-513

# FRAME MOUNTS-CLAMP-ON FOR ROUND TUBING

- ★MOUNTS FOR ROUND TUBING ARE AVAILABLE IN ALUMINUM 2 PIECE AND STEEL 1 & 2 PIECE
- ★SLIDING DESIGNS ARE EASILY ADJUSTABLE
- ★2 PIECE ALUMINUM & 1 PIECE STEEL MOUNTS ACCEPT EITHER 5/8" OR 3/4" ROD ENDS, WHILE THE 2 PIECE STEEL WILL ACCEPT BOTH
- ★2 PIECE STEEL IS AVAILABLE TO FIT EITHER HORIZONTAL OR VERTICAL TUBING



DESCRIPTION	5/8"	3/4"
2 PC. ALUM., 1 1/2" ROUND	570-495	570-497
2 PC. ALUM., 1 3/4" ROUND	570-496	570-498
1 PC. STEEL, 1 1/2" ROUND	570-501	570-502
2 PC. STEEL, 1 1/2" ROUND, HORIZONTAL	570-490	
2 PC. STEEL, 1 1/2" ROUND, VERTICAL	570-493	

NOTE: #570-490 & #570-493 ACCEPT BOTH 5/8" & 3/4" ROD ENDS

Place your order at (479) 646-6988, Fax to (479) 646-5939, or visit [www.southwestspeed.com](http://www.southwestspeed.com)

# BLACK MAGIC LEAF SPRINGS

## MULTI-LEAF CAMARO TYPE

- ★ STOCK REPLACEMENT, 6 1/2" ARCH
- ★ CHROME VANADIUM
- ★ SUPERIOR QUALITY
- ★ 1/2" FRONT MOUNT



DESCRIPTION	PART #
70-81 CAMARO MULTI-LEAF, 150#	550-167
70-81 CAMARO MULTI-LEAF, 175#	550-168
70-81 CAMARO MULTI-LEAF, 200#	550-169
70-81 CAMARO MULTI-LEAF, 225#	550-170
70-81 CAMARO MULTI-LEAF, 250#	550-171

## MULTI-LEAF CHRYSLER TYPE

- ★ SUPERIOR QUALITY
- ★ CHROME VANADIUM
- ★ 5/8" FRONT MOUNT



DESCRIPTION	PART #
4" ARCH MULTI-LEAF, 150#	550-120
5" ARCH MULTI-LEAF, 150#	550-121
4" ARCH MULTI-LEAF, 175#	550-125
5" ARCH MULTI-LEAF, 175#	550-126
4" ARCH MULTI-LEAF, 200#	550-130
5" ARCH MULTI-LEAF, 200#	550-131
4" ARCH MULTI-LEAF, 212#	550-140
5" ARCH MULTI-LEAF, 212#	550-141
4" ARCH MULTI-LEAF, 225#	550-150
5" ARCH MULTI-LEAF, 225#	550-151

## MONO-LEAF CHRYSLER TYPE

- ★ SUPERIOR QUALITY
- ★ CHROME VANADIUM
- ★ 5/8" FRONT MOUNT



DESCRIPTION	PART #
.237" THICK x 5 1/2" ARCH x 25#	550-102
.262" THICK x 4 1/2" ARCH x 35#	550-104
.262" THICK x 5 1/2" ARCH x 35#	550-105
.290" THICK x 4 1/2" ARCH x 45#	550-108
.290" THICK x 5 1/2" ARCH x 45#	550-109
.323" THICK x 4 1/2" ARCH x 60#	550-112
.323" THICK x 5 1/2" ARCH x 60#	550-113

## MULTI-LEAF PINTO TYPE

- ★ STOCK REPLACEMENT, 3 1/2" ARCH
- ★ CHROME VANADIUM
- ★ 1/2" FRONT MOUNT



DESCRIPTION	PART #
74-78 PINTO MULTI-LEAF, 100#	550-192
74-78 PINTO MULTI-LEAF, 125#	550-193
74-78 PINTO MULTI-LEAF, 150#	550-194

# LEAF SPRING BUSHINGS

## FRONT, NITRILE

- ★ CHRYSLER TYPE
- ★ NON-BINDING, 3 PIECE DESIGN WITH STEEL INNER SLEEVE
- ★ #550-019 MEASURES 1.376" O.D. & FITS SOUTHWEST SPEED BLACK MAGIC LEAF SPRINGS, WHILE #550-020 MEASURES 1.491" O.D.



DESCRIPTION	PART #
NITRILE FRONT BUSHING, 1.376" O.D.	550-019
NITRILE FRONT BUSHING, 1.491" O.D.	550-020

## FRONT, PIVOTING

- ★ CHRYSLER TYPE
- ★ NON-BINDING BALL & SOCKET DESIGN WITH STEEL INNER SLEEVE

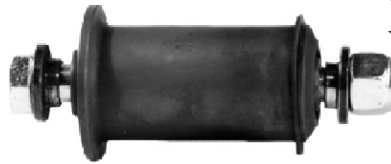

DESCRIPTION	PART #
PIVOTING FRONT BUSHING, 1.376" O.D.	550-024
PIVOTING FRONT BUSHING, 1.491" O.D.	550-025

## REAR, 2 PIECE

- ★ FITS CHRYSLER & PINTO LEAF SPRINGS
- ★ NON-BINDING, 2 PIECE DESIGN WITH ALUMINUM OUTER SLEEVE & STEEL INNER SLEEVE WITH A GREASE FITTING



**PART #550-230**

## REAR, 1 PIECE

- ★ FITS CHRYSLER & PINTO LEAF SPRINGS
- ★ NON-BINDING, 1 PIECE DESIGN AVAILABLE IN NITRILE & ALUMINUM



DESCRIPTION	PART #
1 PIECE NITRILE REAR BUSHING	550-234
1 PIECE ALUMINUM REAR BUSHING	550-235

## REAR, CAMARO

- ★ STOCK REPLACEMENT BUSHINGS FOR 1970-81 CAMARO'S
- ★ SUPERIOR NITRILE CONSTRUCTION
- ★ SOLD IN PAIRS



**PART #550-240**

NOTE: FOR A CONSTANT STREAM OF NEW PRODUCTS & UP-TO-THE-SECOND PRICING, VISIT [WWW.SOUTHWESTSPEED.COM](http://WWW.SOUTHWESTSPEED.COM)

Place your order at (479) 646-6988, Fax to (479) 646-5939, or visit [www.southwestspeed.com](http://www.southwestspeed.com)

# LEAF SPRING FRONT MOUNTS

- ★WELD-ON, FRONT MOUNTS AVAILABLE FOR CHRYSLER & CAMARO STYLE LEAF SPRINGS
- ★MOUNTING HOLES ARE 5/8" BORE ON THE CHRYSLER & 1/2" BORE ON THE CAMARO
- ★GREAT FOR A NEW CHASSIS OR UPDATING AN OLDER ONE
- ★EASILY USED TO ADJUST WEDGE



#550-001  
#550-002



#550-333

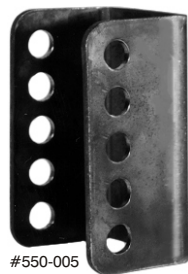

#550-005  
#550-006

DESCRIPTION	PART #
CAMARO, 1 POSITION FRONT MOUNT	550-002
CAMARO, 5 POSITION FRONT MOUNT	550-006
CHRYSLER, 1 POSITION FRONT MOUNT	550-001
CHRYSLER, 5 POSITION FRONT MOUNT	550-005
CHRYSLER, SINGLE SIDE, 1 POS., (EACH)	550-333

# LEAF SPRING FLOATER

- ★STRONG STEEL, SPLIT-TYPE, 3 PIECE DESIGN ALLOWS FOR EASY INSTALLATION & REMOVAL
- ★FITS 3" O.D. TUBES
- ★INCREASES LEAF SPRING LIFE & ISOLATES TORQUE FROM THE LEAF SPRING



PART #550-300

# LEAF SPRING PADS WELD-ON PAD

- ★STEEL PAD WELDS TO 3" O.D. TUBES & FITS 2 1/2" WIDE LEAF SPRINGS
- ★SOLD EACH



PART #550-250

# CLAMP-ON PAD

- ★STEEL PAD CLAMPS TO 3" O.D. TUBE & FITS 2 1/2" WIDE LEAF SPRINGS
- ★SOLD EACH

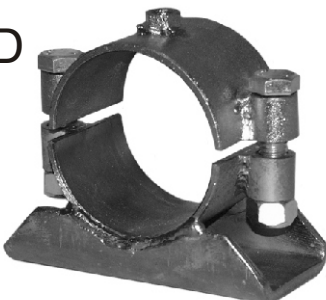

PART #550-252

# LOWERING BLOCKS STANDARD

- ★LIGHTWEIGHT ALUMINUM, STACKABLE DESIGN ALLOWS TO YOU COMBINE BLOCKS TO GET YOUR DESIRED HEIGHT
- ★BLOCKS FIT 2 1/2" WIDE LEAF SPRINGS
- ★ALLOWS YOU TO ADJUST WEDGE



DESCRIPTION	PART #
LOWERING BLOCK, 1/4"	550-349
LOWERING BLOCK, 1/2"	550-350
LOWERING BLOCK, 1"	550-352
LOWERING BLOCK, 1 1/2"	550-354
LOWERING BLOCK, 2"	550-356
LOWERING BLOCK, 2 1/2"	550-358
LOWERING BLOCK, 3"	550-360

# ADJUSTABLE

- ★LIGHTWEIGHT ALUMINUM
- ★FIT 2 1/2" WIDE LEAF SPRINGS
- ★EASILY ALLOWS ADJUSTMENT OF THE TRAIL OR THE LEAD OF THE REAR AXLE

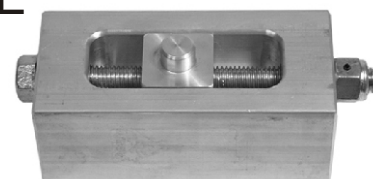

DESCRIPTION	PART #
ADJUSTABLE LOWERING BLOCK, 1 1/2"	550-375
ADJUSTABLE LOWERING BLOCK, 2"	550-376
ADJUSTABLE LOWERING BLOCK, 2 1/2"	550-377
ADJUSTABLE LOWERING BLOCK, 3"	550-378

# LEAF SPRING PADS CLAMP-ON ALUMINUM

- ★LIGHTWEIGHT ALUMINUM PAD CLAMPS TO 3" O.D. TUBES & FITS 2 1/2" WIDE LEAF SPRINGS
- ★DESIGNED TO PROVIDE A 3" LOWERING BLOCK
- ★SOLD EACH



PART #550-260

# CLAMP-ON ALUM., ADJUSTABLE

- ★LIGHTWEIGHT ALUMINUM PAD CLAMPS TO 3" O.D. TUBES & FITS 2 1/2" WIDE LEAF SPRINGS
- ★ADJUSTS THE TRAIL OR THE LEAD OF AN AXLE WITH THE TURN OF A BOLT
- ★SOLD EACH



PART #550-265

Place your order at (479) 646-6988, Fax to (479) 646-5939, or visit [www.southwestspeed.com](http://www.southwestspeed.com)



# LEAF SPRING PLATES UNIVERSAL

- ★FIT 2 1/2" WIDE LEAF SPRINGS
- ★NO SHOCK MOUNT
- ★HIGH CARBON STEEL CONSTRUCTION
- ★SAME LEFT OR RIGHT

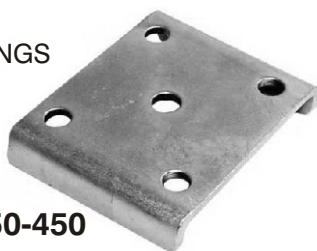

**PART #550-450**

# SINGLE SHOCK MOUNT

- ★FITS 2 1/2" WIDE SPRINGS
- ★1/2" SHOCK HOLES
- ★AVAILABLE WITH THE STANDARD DROP OF 1/2", AS WELL AS DROPS OF 1 1/2" & 2 1/2"
- ★PLATES ARE LEFT & RIGHT SIDE SPECIFIC



#550-454



#550-458

#550-462

DESCRIPTION	LEFT	RIGHT
STEEL, 1/2" DROP	550-454	550-456
STEEL, 1 1/2" DROP	550-458	550-459
STEEL, 2 1/2" DROP	550-460	550-462
ALUMINUM, 1/2" DROP	550-474	550-476

# DUAL SHOCK MOUNT

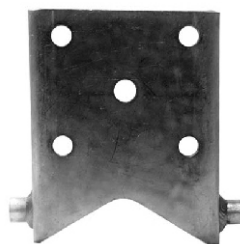

- ★FITS 2 1/2" WIDE SPRINGS
- ★DUAL 1/2" SHOCK HOLES
- ★1 1/2" DROP
- ★HIGH CARBON STEEL CONSTRUCTION
- ★SAME LEFT OR RIGHT

**PART #550-465**

# TRIPLE SHOCK MOUNT

- ★FITS 2 1/2" WIDE LEAF SPRINGS
- ★THREE 1/2" SHOCK HOLES
- ★1 1/2" DROP
- ★HIGH CARBON STEEL CONSTRUCTION
- ★LEFT & RIGHT SPECIFIC

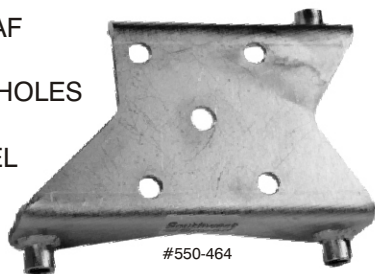

#550-464

DESCRIPTION	LEFT	RIGHT
STEEL, 1 1/2" DROP, TRIPLE	550-463	550-464

NOTE: FOR A CONSTANT STREAM OF NEW PRODUCTS & UP-TO-THE-SECOND PRICING, VISIT [WWW.SOUTHWESTSPEED.COM](http://WWW.SOUTHWESTSPEED.COM)

# U-BOLTS

- ★FITS 3" O.D. TUBES
- ★PLATED STEEL CONSTRUCTION WITH STANDARD 1/2"-20 NUTS
- ★4" THREADS
- ★AVAILABLE 8" & 9 1/2" TALL
- ★SOLD EACH



DESCRIPTION	PART #
8" U-BOLT WITH NUTS	550-278
9 1/2" U-BOLT WITH NUTS	550-279
1/2"-20 STANDARD NUT ONLY, 7/16" TALL	987-918
1/2"-20 HIGH NUT ONLY, 5/8" TALL	550-285

# LEAF SPRING SLIDER BOXES

- ★LEAF SPRING SLIDERS REPLACE SHACKLES
- ★FITS 2 1/2" WIDE LEAF SPRINGS
- ★AVAILABLE FOR CHRYSLER & CAMARO SPRINGS
- ★DESIGNED TO MOUNT EASILY
- ★SLIDER ASSEMBLIES ARE SOLD COMPLETE WITH NITRILE BUSHINGS, ROLLER BEARINGS, & EVERYTHING THAT IS PICTURED



DESCRIPTION	PART #
COMPLETE SLIDER ASSY., CHRYSLER	550-305
COMPLETE SLIDER ASSY., CAMARO	550-306
3 PC. BUSHING KIT ONLY, CHRYSLER	550-308
3 PC. BUSHING KIT ONLY, CAMARO	550-309
REPLACEMENT ROLLER BEARING (1)	550-307

# LEAF SPRING SHACKLE KITS

- ★CUSTOM DESIGNED, STEEL & ALUMINUM SHACKLE KITS
- ★6 POSITIONS OF ADJUSTMENT
- ★SOLD IN SETS OF 4



DESCRIPTION	PART #
SHACKLE KIT, 4 PIECE, STEEL	550-420
SHACKLE KIT, 4 PIECE, ALUMINUM	550-422

# LEAF SPRING SHACKLE ASSY, CHRYSLER

- ★SHACKLE ASSEMBLY FITS 2 1/2" WIDE CHRYSLER LEAF SPRINGS
- ★RUBBER BUSHING DESIGN



**PART #550-320**

Place your order at (479) 646-6988, Fax to (479) 646-5939, or visit [www.southwestspeed.com](http://www.southwestspeed.com)

# RCI FUEL CELLS RECTANGLE

★MANUFACTURED WITH CROSS-LINKED, HIGH-STRENGTH POLYETHYLENE BLADDER

★3 TO 22 GALLON CELLS HAVE A #8 AN MALE PICKUP/OUTLET (UNLESS OTHERWISE NOTED) & A #8 AN MALE ROLLOVER VENT

★32 GALLON CELLS HAVE A #10 AN MALE PICKUP/OUTLET, A #8 AN MALE ROLLOVER VENT, & A #8 AN MALE RETURN



#RCI 1222C

RCI RECTANGLE FUEL CELL SIZE	FUEL CELL WITH CAN	FUEL CELL ONLY	STEEL CAN ONLY
3 GALLON, 12Lx8Wx8H	RCI 1032C	RCI 1031C	-
8 GALLON, 19Lx19Wx8H	RCI 1082C	RCI 1081C	-
12 GALLON, 19Lx19Wx11H	RCI 1122C	RCI 1121C	-
16 GALLON, 25Lx19Wx11H	RCI 1162C	RCI 1161C	RCI 6116A
22 GALLON, 26Lx18Wx15H	RCI 1222C	RCI 1221C	RCI 6122A
22 GALLON, 26x18x15*	RCI 1222C10*	-	-
22 GALLON, 18x26x15**	RCI 1222G**	-	-
22 GALLON, 34Lx18Wx11H	RCI 1212C	RCI 1211C	-
32 GALLON, 26Lx18Wx18H	RCI 1322C	RCI 1321C	RCI 6132A
32 GALLON, 26x18x18#	RCI 1322G#	RCI 1321G#	-

\*1222C10 & 1222G HAVE A #10 PICKUP ON THE TOP, WHILE MOST OTHER 22 GALLON CELLS HAVE A #8 PICKUP ON THE TOP  
\*\*1222G IS DESIGNED SPECIFICALLY FOR CERTAIN CARS TO BE MOUNTED IN THE CAR WITH THE LONG SIDE GOING FRONT TO BACK  
#1322G & 1321G HAVE A #10 90° FITTING PICKUP ON THE RIGHT REAR OF THE CELLS

# TEAR DROP CELLS

★FEATURING A #10 AN PICKUP/OUTLET, A #8 AN MALE ROLLOVER VENT, & A #8 AN MALE RETURN

★AVAILABLE WITH OR WITHOUT THE STEEL CAN & WITH OR WITHOUT FOAM



RCI TEARDROP FUEL CELL SIZE	FUEL CELL WITH CAN	CELL WITH CAN & FOAM	FUEL CELL ONLY
22 GALLON, 25x24x13	RCI 1222H	-	-
32 GALLON, 25x24x18	RCI 1322DW	-	-
32 GALLON, 29x25x16	RCI 5325S	RCI 5326S	RCI 5323S

# DRAG RACE CELLS

★CROSS-LINKED, POLYETHYLENE BLADDERS

★INCLUDES:

#8 AN MALE FITTINGS, 2 PICKUPS ON 2" SUMP, & ROLLOVER VENT

★AVAILABLE WITH OR WITHOUT FOAM

★U-BRACKET MOUNTING KITS ARE AVAILABLE AS WELL

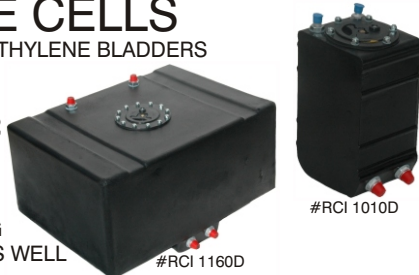

#RCI 1010D

#RCI 1160D

RCI DRAG FUEL CELLS	NO FOAM	WITH FOAM	MOUNT KIT
1 GALLON, 6Lx6Wx12H	RCI 1010D	RCI 2010D	-
4 GALLON, 9Lx9Wx12H	RCI 1040D	RCI 2040D	RCI 7404A
5 GALLON, 13Lx13Wx8H	RCI 1050D	RCI 2050D	RCI 7405A
8 GALLON, 17Lx17Wx8H	RCI 1080D	RCI 2080D	RCI 7408A
12 GALLON, 17Lx17Wx11H	RCI 1120D	RCI 2120D	RCI 7412A
12 GAL, 17x17x11, SENDING	RCI 1120DS	-	RCI 7412A
16 GALLON, 23Lx17Wx11H	RCI 1160D	RCI 2160D	RCI 7416A
16 GAL, 23x17x11, SENDING	RCI 1160DS	-	RCI 7416A

# FUEL CELL FOAM

★DIMENSIONS ARE 3" X 6" X 16"

★CAN BE LAYED DOWN IN THE CELL TO MAKE A 3" DEEP LAYER OR STOOD ON ITS SIDE TO MAKE A 6" DEEP LAYER

★PRICED & SOLD INDIVIDUALLY

PART #  
RRP 2070



# RCI FUEL CELLS ALUM STREET ROD

★TIG-WELDED 5051 AIRCRAFT ALUMINUM

★#8 AN FITTINGS & ROLLOVER VENT

★AVAILABLE WITH FOAM

& WITH SENDING UNITS



#RCI 2050A

#RCI 2172A



#RCI 2030A

RCI ALUMINUM FUEL CELLS WITH FOAM	RCI ALUMINUM FUEL CELLS WITH FOAM	MOUNT KIT
1 GALLON, 7Lx6Wx8H	RCI 2010A	-
3 GALLON, 8Lx8Wx15H	RCI 2030A	RCI 7502A
4 GALLON, 8Lx12Wx8H	RCI 2040A	RCI 7503A
5 GALLON, 12Lx12Wx8H	RCI 2050A	RCI 7504A
10 GALLON, 17Lx17Wx9H	RCI 2100A	RCI 7505A
10 GAL, 17x17x9, SENDING	RCI 2100AS	RCI 7505A
15 GALLON, 18Lx20Wx10H	RCI 2150A	RCI 7506A
15 GAL, 18x20x10, W/SENDING	RCI 2150AS	RCI 7506A
20 GALLON, 24Lx20Wx10H	RCI 2200A	RCI 7509A
20 GAL, 24x20x10, W/SENDING	RCI 2200AS	RCI 7509A
RCI ALUM CELLS WITH SENDING UNIT, NO FOAM	MOUNT KIT	
12 GALLON, 18Lx12Wx12H	RCI 2121A	RCI 7511A
15 GALLON, 30Lx9Wx12H	RCI 2161A	RCI 7512A
15 GALLON, 30Lx12Wx9H	RCI 2162A	RCI 7513A
17 GALLON, 30Lx7Wx17H	RCI 2171A	RCI 7514A
17 GALLON, 30Lx17Wx7H	RCI 2172A	RCI 7515A
19 GALLON, 30Lx12Wx12H	RCI 2191A	RCI 7516A

# ATL FUEL CELLS RECTANGLE

★ATL FUEL CELLS FEATURE A MOLDED, SEAMLESS BLADDER

★EXCELLENT RESISTANCE TO RACE GAS & ALCOHOL

★SF-103 FOAM BAFFLING

★POWDER-COATED "FLAP VALVE" FILL PLATE

★HIGH-QUALITY HARDWARE THROUGHOUT

★CELLS COME WITH FILL & VENT CHECK VALVES, A #10 AN OUTLET/PICKUP, & A #10 AN MALE RETURN

★SOLD WITH STEEL CAN & WITH OR WITHOUT FOAM



ATL RECTANGLE FUEL CELL SIZE	FUEL CELL WITH CAN & FOAM	CELL WITH CAN; NO FOAM
22 GALLON, 25 x 17 x 14	ATL SP122B-LM	ATL SP122B-LMNF
32 GALLON, 26 x 19 x 17	ATL SP132B-LM	-

# CAPS, FLANGES, & GASKETS

★PLATED STEEL CONSTRUCTION; CAPS ARE AVAILABLE WITH OR WITHOUT FLANGES IN BOTH VENTED & NON-VENTED

★DIRECT REPLACEMENT FOR MOST D-RING STYLE CELLS

★ASSEMBLIES INCLUDE CAP,

FLANGE,

GASKET, &

BOTTOM

RING



#800-092

#800-089

#800-091

DESCRIPTION	PART #
FUEL CELL CAP ONLY, NON-VENTED	800-089
FUEL CELL CAP ONLY, VENTED	800-090
CAP & FLANGE ASSY., NON-VENTED	800-093
CAP & FLANGE ASSY., VENTED	800-092
REPLACEMENT CAP GASKET ONLY	800-0901
D-RING FLANGE ONLY	800-091
FLANGE GASKET ONLY	800-0911
FLANGE BACKUP RING ONLY	800-0912

# 45° FAST FILL ADAPTER

★LARGE 2 1/4" OPENING

★ONE WAY FLAPPER VALVE

★12 BOLT FLANGE

★FLANGE GASKET & BOLTS INCLUDED

★REPLACES D-RING CAP & FLANGE



PART #  
RCI 7038A

Place your order at (479) 646-6988, Fax to (479) 646-5939, or visit [www.southwestspeed.com](http://www.southwestspeed.com)

# FUEL CELL VENT & ROLLOVER VALVE



- ★-8 AN FITTING
- ★VENTS FUEL CELL
- ★BALL VALVE WILL HELP PREVENT SPILLS
- ★COMES COMPLETE WITH NUTS & WASHERS

**PART #890-100**

# 90° BULKHEAD KITS

- ★KIT COMES COMPLETE WITH A JAM NUT & 2 NYLON WASHERS
- ★PERFECT FOR FUEL CELLS
- ★3 DIFFERENT SIZES TO CHOOSE FROM



DESCRIPTION	PART #
90° BULKHEAD KIT, -8AN	905-108
90° BULKHEAD KIT, -10AN	905-110
90° BULKHEAD KIT, -12AN	905-112

# FUEL JUGS

- ★SQUARE, LARGE MOUTH, 5 GALLON FUEL JUGS
- ★DURABLE PLASTIC CONSTRUCTION WITH A VENT
- ★JUGS COME WITH JUG CAP & VENT CAP



#RCI 7071A

#RCI 7071D

DESCRIPTION	PART #
SQUARE 5 GALLON JUG, WHITE	RCI 7070AV
SQUARE 5 GALLON JUG, RED	RCI 7070BV
SQUARE 5 GALLON JUG, BLUE	RCI 7070CV
REPLACEMENT FUEL JUG CAP	RCI 7071A
OPTIONAL FUEL JUG CAP W/ HOSE	RCI 7071D
REPLACEMENT FUEL JUG VENT CAP	RCI 7071V

# TRIANGLE FUEL FUNNEL

- ★12" DIAMETER TRIANGLE FUEL FUNNEL
- ★LARGE OPENING ALLOWS FOR FAST FUELING WITH LITTLE SPILLAGE



**PART #RCI 7010B**

# FUEL FILTERS - INLINE

- ★AVAILABLE WITH 7 MICRON FIBER ELEMENT & 63 MICRON STAINLESS STEEL ELEMENT, WITH -6, -8, -10, -12, OR -16 AN END CAPS
- ★LIGHTWEIGHT ALUMINUM CONSTRUCTION WITH LARGE FILTERING AREA



DESCRIPTION	PART #
-6 AN FUEL FILTER, FIBER	411-210
-6 AN FUEL FILTER, STAINLESS STEEL	411-2106
-8 AN FUEL FILTER, FIBER	411-212
-8 AN FUEL FILTER, STAINLESS STEEL	411-2126
-10 AN FUEL FILTER, FIBER	411-214
-10 AN FUEL FILTER, STAINLESS STEEL	411-2146
-12 AN FUEL FILTER, FIBER	411-216
-12 AN FUEL FILTER, STAINLESS STEEL	411-2166
-16 AN FUEL FILTER, FIBER	411-218
-16 AN FUEL FILTER, STAINLESS STEEL	411-2186

REPLACEMENT PARTS	PART #
FIBER FILTER ELEMENT ONLY	411-222
STAINLESS STEEL ELEMENT ONLY	411-226
-6 AN END CAP	411-2299
-8 AN END CAP	411-230
-10 AN END CAP	411-232
-12 AN END CAP	411-234
-16 AN END CAP	411-2341
O-RING KIT, 2 PIECES	411-236
ELEMENT RETENTION SPRING	411-238

# INLINE FUEL FILTER BRACKETS

- ★ANODIZED BLACK 7075 T-6 ALUMINUM
- ★MOUNT TO SQUARE OR ROUND TUBING
- ★EASY-TO-USE, 2 PIECE DESIGN



DESCRIPTION	PART #
FILTER BRACKET, 1 1/4" ROUND TUBE	411-254
FILTER BRACKET, 1 1/2" ROUND TUBE	411-258
FILTER BRACKET, 1 3/4" ROUND TUBE	411-262
FILTER BRACKET, 2" SQUARE TUBE	411-280

NOTE: FOR A CONSTANT STREAM OF NEW PRODUCTS & UP-TO-THE-SECOND PRICING, VISIT [WWW.SOUTHWESTSPEED.COM](http://WWW.SOUTHWESTSPEED.COM)

Place your order at (479) 646-6988, Fax to (479) 646-5939, or visit [www.southwestspeed.com](http://www.southwestspeed.com)



# SWS FUEL LOGS

- ★AVAILABLE FOR 4 BBL 4150/4160 & DEMON
- ★INCLUDES FUEL LOG TUBE, INLET & OUTLET FITTINGS, OUTLET FITTING CAP, & 2 CARB INLET LINES WITH EITHER CLEAR HOSE (4150 ECONO), RIGID TUBES (4150 RIGID), OR SWIVEL FITTINGS (DEMON)



- ★LIGHTWEIGHT ANODIZED ALUMINUM
- ★CLEARS ALL ACCELERATOR PUMPS



DESCRIPTION	PART #
4150 ECONO LOG, -8 AN IN, -6 AN OUT	411-100
4150 RIGID LOG, -8 AN IN, -4 AN OUT	411-101
4150 RIGID LOG, -8 AN IN, -6 AN OUT	411-103
4150 RIGID LOG, -8 AN IN, -8 AN OUT	411-104
4150 RIGID LOG, -10 AN IN, -6 AN OUT	411-105
4150 RIGID LOG, -10 AN IN, -8 AN OUT	411-107
DEMON FUEL LOG, -8 AN IN, -4 AN OUT	411-151
DEMON FUEL LOG, -8 AN IN, -6 AN OUT	411-153
DEMON FUEL LOG, -8 AN IN, -8 AN OUT	411-154
DEMON FUEL LOG, -10 AN IN, -6 AN OUT	411-155
DEMON FUEL LOG, -10 AN IN, -8 AN OUT	411-157
4150 FUEL LOG TUBE ONLY	411-120
DEMON FUEL LOG, TUBE ONLY	411-121
-8 AN MALE HOLLEY ADAPTER FITTING	411-110
-8 AN SWIVEL TUBE ASSEMBLY ONLY	411-112

# BARRY GRANT FUEL LOGS

- ★AIRCRAFT GRADE BILLET ALUMINUM
- ★HIGH VOLUME CAPABILITIES
- ★TRIPLE O-RING SEALED
- ★AVAILABLE WITH PILL BYPASS & DIAPHRAGM BYPASS
- ★#170021N & #170031 FEATURE A NEW ADJUSTABLE DESIGN THAT ALLOWS THE FUEL LOG TO BE CHANGED TO FIT 4150 & 4500 SERIES CARBURETORS



DESCRIPTION	PART #
LOG, 2 OUTLET, W/ BYPASS & PILLS	BGF 170020
LOG, 2 OUTLET	BGF 170021
LOG, 2 OUTLET, ADJUSTABLE	BGF 170021N
LOG, 2 OUT, ADJ. W/DIAPHRAGM BY.	BGF 170031

# HOSE

## BLUE PUSH LOCK HOSE

- ★USE WITH BRASS, STEEL, OR ALUMINUM PUSH LOCK FITTINGS
- ★AVAILABLE WITH 3 DIFFERENT INSIDE DIAMETERS
- ★PRICED PER FOOT & SOLD IN INCREMENTS OF 20'\*\*\*

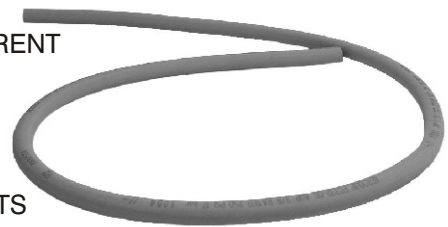

DESCRIPTION	PART #
#6 BLUE PUSH LOCK HOSE, 3/8" I.D.	927-966
#8 BLUE PUSH LOCK HOSE, 1/2" I.D.	927-968
#10 BLUE PUSH LOCK HOSE, 5/8" I.D.	927-970

## CLEAR BRAIDED VINYL PUSH LOCK

- ★USE WITH BRASS, STEEL, OR ALUMINUM PUSH LOCK FITTINGS
- ★AVAILABLE WITH 3 DIFFERENT INSIDE DIAMETERS
- ★PRICED PER FOOT & SOLD IN INCREMENTS OF 20'\*\*\*

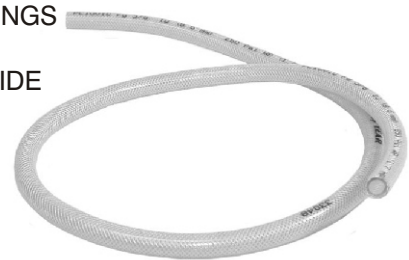

DESCRIPTION	PART #
CLEAR BRAIDED HOSE, 3/8" I.D.	927-986
CLEAR BRAIDED HOSE, 1/2" I.D.	927-988
CLEAR BRAIDED HOSE, 5/8" I.D.	927-990

\*\*\*MOST PUSH LOCK HOSE SIZES HAVE RANDOM LENGTHS AVAILABLE. IF YOU NEED ANOTHER LENGTH BESIDES ONE IN A 20' INCREMENT, ASK YOUR SALESMAN IF WE HAVE SOMETHING ELSE AVAILABLE

## STEEL BRAIDED HOSE

- ★WIRE REINFORCED INNER HOSE
- ★STAINLESS STEEL BRAIDED OUTER LAYER
- ★SEVERAL SIZES AVAILABLE
- ★PRICED PER FOOT & SOLD IN INCREMENTS OF 10'



DESCRIPTION	PART #
-4 AN STEEL BRAIDED HOSE	900-004
-6 AN STEEL BRAIDED HOSE	900-006
-8 AN STEEL BRAIDED HOSE	900-008
-10 AN STEEL BRAIDED HOSE	900-010
-12 AN STEEL BRAIDED HOSE	900-012
-16 AN STEEL BRAIDED HOSE	900-016

NOTE: FOR A CONSTANT STREAM OF NEW PRODUCTS & UP-TO-THE-SECOND PRICING, VISIT [WWW.SOUTHWESTSPEED.COM](http://WWW.SOUTHWESTSPEED.COM)

Place your order at (479) 646-6988, Fax to (479) 646-5939, or visit [www.southwestspeed.com](http://www.southwestspeed.com)

# PUSH LOCK HOSE ENDS

- ★PUSH LOCK FITTINGS HAVE BARBED ENDS THAT PUSH IN & STAY LOCKED
- ★STRAIGHT, 45°, 90°, 120°, 150°, & 180° AVAILABLE IN BRASS, STEEL, & ANODIZED ALUMINUM

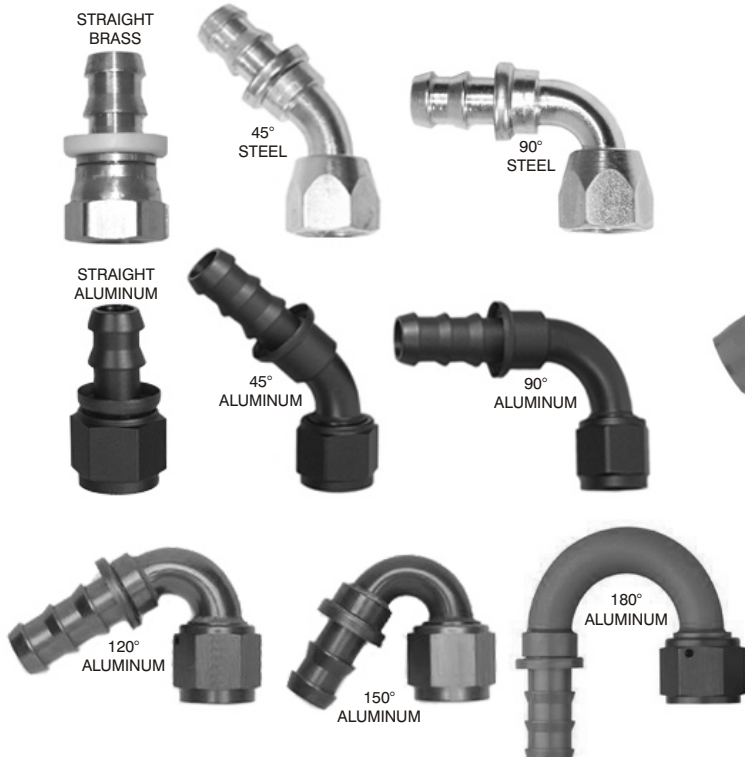

# BRAIDED HOSE ENDS

- ★ANODIZED ALUMINUM HOSE ENDS FOR STEEL BRAIDED HOSE
- ★COMPRESSION TYPE
- ★BRAZED TUBE FOR MAXIMUM FLUID FLOW

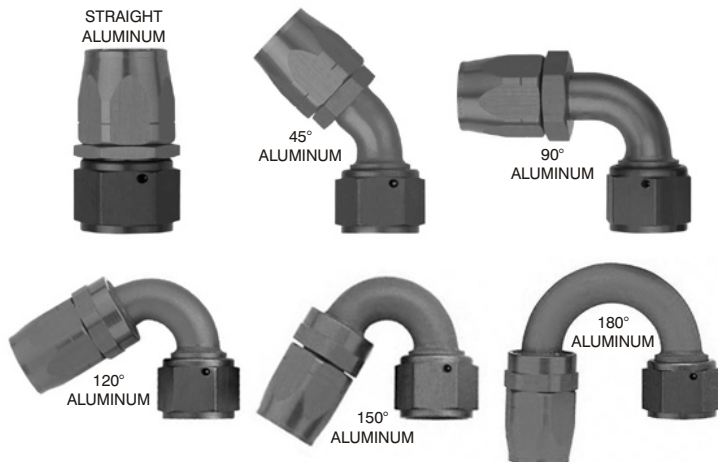

STRAIGHT HOSE ENDS	BRASS	ALUM.
3/8" HOSE TO -6 AN FITTING	928-006	928-106
3/8" HOSE TO -8 AN FITTING	928-007	-
1/2" HOSE TO -8 AN FITTING	928-008	928-108
1/2" HOSE TO -10 AN FITTING	-	928-109
5/8" HOSE TO -8 AN FITTING	928-009	-
5/8" HOSE TO -10 AN FITTING	928-010	928-110

45° HOSE ENDS	STEEL	ALUM.
3/8" HOSE TO -6 AN FITTING	928-026	928-126
1/2" HOSE TO -8 AN FITTING	928-028	928-128
5/8" HOSE TO -10 AN FITTING	-	928-130

90° HOSE ENDS	STEEL	ALUM.
3/8" HOSE TO -6 AN FITTING	928-036	928-136
1/2" HOSE TO -8 AN FITTING	928-038	928-138
5/8" HOSE TO -10 AN FITTING	928-040	928-140

120° HOSE ENDS	ALUM.
3/8" HOSE TO -6 AN FITTING	928-146
1/2" HOSE TO -8 AN FITTING	928-148
5/8" HOSE TO -10 AN FITTING	928-150

150° HOSE ENDS	ALUM.
3/8" HOSE TO -6 AN FITTING	928-156
1/2" HOSE TO -8 AN FITTING	928-158
5/8" HOSE TO -10 AN FITTING	928-160

180° HOSE ENDS	ALUM.
3/8" HOSE TO -6 AN FITTING	928-166
1/2" HOSE TO -8 AN FITTING	928-168
5/8" HOSE TO -10 AN FITTING	928-170

BRAIDED HOSE ENDS	STR.	ALUM.
-4 AN HOSE TO -4 AN FITTING,	STR.	901-011
-6 AN HOSE TO -6 AN FITTING,	STR.	901-012
-8 AN HOSE TO -8 AN FITTING,	STR.	901-013
-10 AN HOSE TO -10 AN FITTING,	STR.	901-014
-12 AN HOSE TO -12 AN FITTING,	STR.	901-015
-16 AN HOSE TO -16 AN FITTING,	STR.	901-016
-4 AN HOSE TO -4 AN FITTING,	45°	901-021
-6 AN HOSE TO -6 AN FITTING,	45°	901-022
-8 AN HOSE TO -8 AN FITTING,	45°	901-023
-10 AN HOSE TO -10 AN FITTING,	45°	901-024
-12 AN HOSE TO -12 AN FITTING,	45°	901-025
-16 AN HOSE TO -16 AN FITTING,	45°	901-026
-4 AN HOSE TO -4 AN FITTING,	90°	901-031
-6 AN HOSE TO -6 AN FITTING,	90°	901-032
-8 AN HOSE TO -8 AN FITTING,	90°	901-033
-10 AN HOSE TO -10 AN FITTING,	90°	901-034
-12 AN HOSE TO -12 AN FITTING,	90°	901-035
-16 AN HOSE TO -16 AN FITTING,	90°	901-036
-4 AN HOSE TO -4 AN FITTING,	120°	901-041
-6 AN HOSE TO -6 AN FITTING,	120°	901-042
-8 AN HOSE TO -8 AN FITTING,	120°	901-043
-10 AN HOSE TO -10 AN FITTING,	120°	901-044
-12 AN HOSE TO -12 AN FITTING,	120°	901-045
-16 AN HOSE TO -16 AN FITTING,	120°	901-046
-4 AN HOSE TO -4 AN FITTING,	150°	901-051
-6 AN HOSE TO -6 AN FITTING,	150°	901-052
-8 AN HOSE TO -8 AN FITTING,	150°	901-053
-10 AN HOSE TO -10 AN FITTING,	150°	901-054
-12 AN HOSE TO -12 AN FITTING,	150°	901-055
-16 AN HOSE TO -16 AN FITTING,	150°	901-056
-4 AN HOSE TO -4 AN FITTING,	180°	901-061
-6 AN HOSE TO -6 AN FITTING,	180°	901-062
-8 AN HOSE TO -8 AN FITTING,	180°	901-063
-10 AN HOSE TO -10 AN FITTING,	180°	901-064
-12 AN HOSE TO -12 AN FITTING,	180°	901-065
-16 AN HOSE TO -16 AN FITTING,	180°	901-066

Place your order at (479) 646-6988, Fax to (479) 646-5939, or visit [www.southwestspeed.com](http://www.southwestspeed.com)

# NPT TO -AN ADAPTERS MALE TO MALE

- ★ STRAIGHT, 45°, & 90° ADAPTERS AVAILABLE IN BOTH ANODIZED ALUMINUM & STEEL
- ★ ADAPTS NPT TO -AN
- ★ REDUCES HOSE ENDS

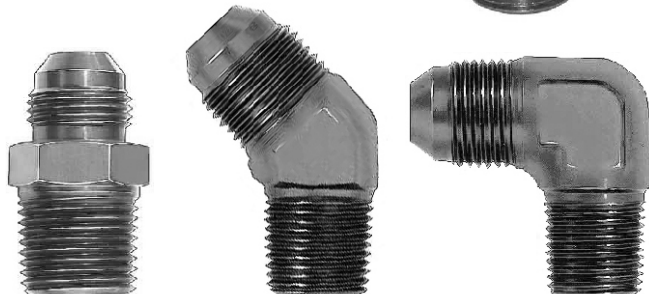

DESCRIPTION	PART #
ALUM, 1/8" NPT MALE TO -3 AN MALE	902-000
ALUM, 1/8" NPT MALE TO -4 AN MALE	902-001
ALUM, 1/4" NPT MALE TO -4 AN MALE	902-002
ALUM, 1/8" NPT MALE TO -6 AN MALE	902-003
ALUM, 1/4" NPT MALE TO -6 AN MALE	902-004
ALUM, 3/8" NPT MALE TO -6 AN MALE	902-005
ALUM, 1/2" NPT MALE TO -6 AN MALE	902-015
ALUM, 1/4" NPT MALE TO -8 AN MALE	902-006
ALUM, 3/8" NPT MALE TO -8 AN MALE	902-007
ALUM, 1/2" NPT MALE TO -8 AN MALE	902-008
ALUM, 1/2" NPT MALE TO -10 AN MALE	902-009
ALUM, 3/8" NPT MALE TO -10 AN MALE	902-185
ALUM, 1/2" NPT MALE TO -12 AN MALE	902-010
ALUM, 3/4" NPT MALE TO -12 AN MALE	902-011
ALUM, 1" NPT MALE TO -12 AN MALE	902-014
ALUM, 1/8" NPT MALE TO -3 AN MALE, 45°	902-020
ALUM, 1/8" NPT MALE TO -4 AN MALE, 45°	902-021
ALUM, 1/4" NPT MALE TO -6 AN MALE, 45°	902-022
ALUM, 3/8" NPT MALE TO -8 AN MALE, 45°	902-023
AL., 1/2" NPT MALE TO -10 AN MALE, 45°	902-024
AL., 3/4" NPT MALE TO -12 AN MALE, 45°	902-025
ALUM, 1/8" NPT MALE TO -3 AN MALE, 90°	902-030
ALUM, 1/8" NPT MALE TO -4 AN MALE, 90°	902-031
ALUM, 1/4" NPT MALE TO -4 AN MALE, 90°	902-032
ALUM, 1/4" NPT MALE TO -6 AN MALE, 90°	902-034
ALUM, 3/8" NPT MALE TO -6 AN MALE, 90°	902-035
ALUM, 1/4" NPT MALE TO -8 AN MALE, 90°	902-036
ALUM, 3/8" NPT MALE TO -8 AN MALE, 90°	902-037
ALUM, 1/2" NPT MALE TO -8 AN MALE, 90°	902-038
AL., 1/2" NPT MALE TO -10 AN MALE, 90°	902-039
AL., 3/4" NPT MALE TO -12 AN MALE, 90°	902-040
STEEL, 1/8" NPT MALE TO -4 AN MALE	902-512
STEEL, 1/2" NPT MALE TO -4 AN MALE	902-524
STEEL, 1/2" NPT MALE TO -6 AN MALE	902-525
STEEL, 1/2" NPT MALE TO -8 AN MALE	902-526
STEEL, 1/2" NPT MALE TO -12 AN MALE	902-528
STEEL, 3/4" NPT MALE TO -16 AN MALE	902-533
STEEL, 3/8" NPT MALE TO -8AN MALE, 90°	902-621

# FEMALE TO MALE ADAPTERS

- ★ ANODIZED ALUMINUM, STEEL, & BRASS FITTINGS AVAILABLE
- ★ REDUCES LARGER FITTINGS DOWN TO SMALLER FITTINGS

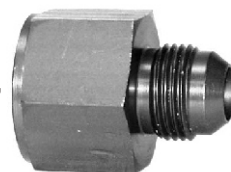

DESCRIPTION	PART #
ALUM., -10 AN FEMALE TO -8 AN MALE	901-090
ALUM., -12 AN FEMALE TO -10 AN MALE	901-092
ALUM., -16 AN FEMALE TO -12 AN MALE	901-094
STEEL, -12 AN FEMALE TO -10 AN MALE	902-422
BRASS, 1/8" NPT FEMALE TO -4 AN MALE	902-721

# -AN UNIONS

- ★ ANODIZED ALUMINUM UNIONS
- ★ JOINS 2 FEMALE FITTINGS



DESCRIPTION	PART #
UNION, -3 AN TO -3 AN	902-050
UNION, -4 AN TO -4 AN	902-051
UNION, -6 AN TO -6 AN	902-052
UNION, -8 AN TO -8 AN	902-053
UNION, -8 AN TO -8 AN, 45°	902-1901
UNION, -8 AN TO -8 AN, 90°	902-190
UNION, -10 AN TO -10 AN	902-054
UNION REDUCER, -3 AN TO -4 AN	902-048
UNION REDUCER, -4 AN TO -6 AN	902-156
UNION REDUCER, -6 AN TO -8 AN	902-160
UNION REDUCER, -6 AN TO -10 AN	902-162
UNION REDUCER, -8 AN TO -10 AN	902-163

# -AN COUPLERS



- ★ -AN SWIVEL COUPLERS JOIN 2 MALE FITTINGS TOGETHER
- ★ ANODIZED ALUMINUM

DESCRIPTION	PART #
-4 AN FEMALE TO -4 AN FEMALE	902-914
-6 AN FEMALE TO -6 AN FEMALE	902-915
-8 AN FEMALE TO -8 AN FEMALE	902-916

# -AN END CAPS

- ★ ANODIZED ALUMINUM
- ★ SEALS MALE -AN FITTINGS
- ★ SOLD EACH

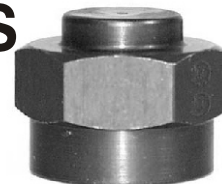

DESCRIPTION	PART #
ALUMINUM END CAP, -4 AN	903-752
ALUMINUM END CAP, -6 AN	903-740
ALUMINUM END CAP, -8 AN	903-741
ALUMINUM END CAP, -10 AN	903-742
ALUMINUM END CAP, -12 AN	903-743
ALUMINUM END CAP, -16 AN	903-744

Place your order at (479) 646-6988, Fax to (479) 646-5939, or visit [www.southwestspeed.com](http://www.southwestspeed.com)



## -AN FLARE PLUGS



- ★SCREWS INTO FEMALE -AN FITTINGS TO PLUG THEM
- ★ANODIZED ALUMINUM

DESCRIPTION	PART #
ALUMINUM FLARE PLUG, -4 AN	903-713
ALUMINUM FLARE PLUG, -6 AN	903-714
ALUMINUM FLARE PLUG, -8 AN	903-715
ALUMINUM FLARE PLUG, -10 AN	903-716
ALUMINUM FLARE PLUG, -12 AN	903-717
ALUMINUM FLARE PLUG, -16 AN	903-718

## -AN O-RING BOSS PLUGS

- ★PLUGS STRAIGHT THREADED HOLES
- ★ANODIZED ALUMINUM
- ★O-RING INCLUDED

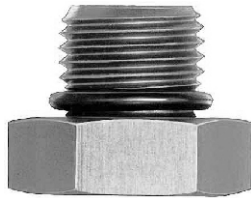

DESCRIPTION	PART #
O-RING BOSS PLUG, -4 AN	903-723
O-RING BOSS PLUG, -6 AN	903-724
O-RING BOSS PLUG, -8 AN	903-725
O-RING BOSS PLUG, -10 AN	903-726
O-RING BOSS PLUG, -12 AN	903-727

## -AN JAM NUTS

- ★-AN JAM NUTS
- ★SOLD EACH

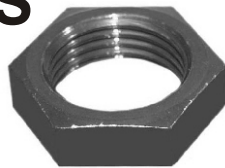

DESCRIPTION	PART #
ALUMINUM JAM NUT, -4 AN	902-099
ALUMINUM JAM NUT, -6 AN	902-100
ALUMINUM JAM NUT, -8 AN	902-103
ALUMINUM JAM NUT, -10 AN	902-104
ALUMINUM JAM NUT, -12 AN	902-105
STEEL JAM NUT, -4 AN	902-299

## -AN WASHERS

- ★ALUMINUM & NYLON SEALING WASHERS
- ★SOLD PACKS OF 4 OR 5

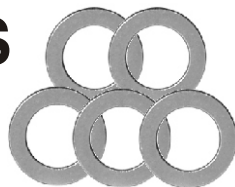

DESCRIPTION	PART #
ALUMINUM WASHERS, -3 AN (5 PCS.)	903-642
ALUMINUM WASHERS, -4 AN (5 PCS.)	903-643
ALUMINUM WASHERS, -10 AN (5 PCS.)	903-650
NYLON WASHERS, -6 AN (4 PCS.)	905-116
NYLON WASHERS, -8 AN (4 PCS.)	905-118
NYLON WASHERS, -10 AN (4 PCS.)	905-120
NYLON WASHERS, -12 AN (4 PCS.)	905-122

## -AN MALE TEES

- ★MALE TEES TO CONNECT 3 FEMALE FITTINGS TOGETHER
- ★ANODIZED ALUMINUM



DESCRIPTION	PART #
ALUMINUM MALE TEE, -4 AN	902-061
ALUMINUM MALE TEE, -6 AN	902-062
ALUMINUM MALE TEE, -8 AN	902-063
ALUMINUM MALE TEE, -10 AN	902-064

## -AN BULKHEAD TEE



- ★MALE BULKHEAD TEE FITTING TO CONNECT THREE -4 AN FEMALE FITTINGS
- ★ANODIZED ALUMINUM

PART #902-091

## -AN BULKHEADS

- ★STRAIGHT BULKHEAD FITTINGS TO CONNECT -AN FEMALE FITTINGS
- ★ANODIZED ALUMINUM & STEEL



DESCRIPTION	PART #
ALUMINUM BULKHEAD, -4 AN	902-071
ALUMINUM BULKHEAD, -6 AN	902-072
ALUMINUM BULKHEAD, -8 AN	902-073
ALUMINUM BULKHEAD, -10 AN	902-074
ALUMINUM BULKHEAD, -12 AN	902-075
STEEL BULKHEAD, -4 AN	902-771

## -AN 90° BULKHEADS



- ★90° BULKHEADS TO CONNECT -AN FEMALE FITTINGS
- ★KITS COME COMPLETE WITH 2 WASHERS & A JAM NUT

DESCRIPTION	PART #
90° ALUM. BULKHEAD KIT, -8 AN	905-108
90° ALUM. BULKHEAD KIT, -10 AN	905-110
90° ALUM. BULKHEAD KIT, -12 AN	905-112
90° BULKHEAD FITTING ONLY, -8 AN	902-083
90° BULKHEAD FITTING ONLY, -10 AN	902-084
90° BULKHEAD FITTING ONLY, -12 AN	902-085

Place your order at (479) 646-6988, Fax to (479) 646-5939, or visit [www.southwestspeed.com](http://www.southwestspeed.com)

## NPT PIPE NIPPLES



- ★ JOINS FEMALE PIPE FITTINGS TOGETHER
- ★ ANODIZED ALUMINUM
- ★ SOLD EACH

DESCRIPTION	PART #
1/8" NPT MALE TO 1/8" NPT MALE	902-132
1/4" NPT MALE TO 1/4" NPT MALE	902-133
3/8" NPT MALE TO 3/8" NPT MALE	902-134
1/2" NPT MALE TO 1/2" NPT MALE	902-135

## NPT PIPE BUSHINGS

- ★ REDUCES FEMALE PIPE FITTINGS
- ★ BUSHINGS SCREW INTO FEMALE FITTINGS & HAVE FEMALE THREADS ON THE INSIDE
- ★ ANODIZED ALUMINUM



DESCRIPTION	PART #
1/4" NPT MALE TO 1/8" NPT FEMALE	902-136
3/8" NPT MALE TO 1/8" NPT FEMALE	902-138
3/8" NPT MALE TO 1/4" NPT FEMALE	902-137
1/2" NPT MALE TO 1/8" NPT FEMALE	902-141
1/2" NPT MALE TO 1/4" NPT FEMALE	902-140
1/2" NPT MALE TO 3/8" NPT FEMALE	902-139
3/4" NPT MALE TO 1/2" NPT FEMALE	902-142
1" NPT MALE TO 3/4" NPT FEMALE	902-145

## NPT PIPE COUPLERS

- ★ PIPE COUPLINGS JOIN 2 MALE NPT FITTINGS TOGETHER
- ★ ANODIZED ALUMINUM



DESCRIPTION	PART #
1/8" NPT FEMALE TO 1/8" NPT FEMALE	902-129
1/4" NPT FEMALE TO 1/4" NPT FEMALE	902-130
3/8" NPT FEMALE TO 3/8" NPT FEMALE	902-131

## NPT PIPE PLUGS

- ★ SCREWS INTO FEMALE NPT FITTINGS TO PLUG THEM
- ★ ALLEN HEAD
- ★ ANODIZED ALUMINUM & MAGNETIC PLUGS AVAILABLE
- ★ GREAT FOR TRANSMISSION, REAR END, ENGINE, ETC. DRAIN PLUGS & INSPECTION PLUGS



DESCRIPTION	ALUM. #	MAGNETIC #
PIPE PLUG, 1/8" NPT	903-685	906-0002
PIPE PLUG, 1/4" NPT	903-686	906-0003
PIPE PLUG, 3/8" NPT	903-687	906-0004
PIPE PLUG, 1/2" NPT	903-749	906-0005
PIPE PLUG, 3/4" NPT	903-750	906-0006
PIPE PLUG, 1" NPT	903-751	-

## ALUMINUM -AN WRENCH SET

- ★ ANODIZED ALUMINUM, 5 PIECE -AN WRENCH SET
- ★ -6, -8, -10, -12, & -16 AN WRENCHES



PART #900-000

## ADEL LINE CLAMPS

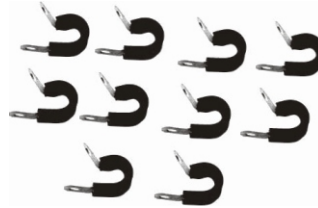

- ★ MAKES A NEAT & SAFE INSTALLATION OF HOSES & WIRES
- ★ FEATURES A HIGH TEMPERATURE, NEOPRENE LINING

DESCRIPTION	PACK OF 10	BOX OF 100
ADEL CLAMPS, -3	900-203	900-233
ADEL CLAMPS, -4	900-204	900-234
ADEL CLAMPS, -5	900-205	900-235
ADEL CLAMPS, -6	900-206	900-236
ADEL CLAMPS, -7	900-207	900-237
ADEL CLAMPS, -8	900-208	900-238
ADEL CLAMPS, -9	900-209	900-239
ADEL CLAMPS, -10	900-210	900-240
ADEL CLAMPS, -11	900-211	900-241
ADEL CLAMPS, -12	900-212	900-242
ADEL CLAMPS, -15	900-215	900-245
ADEL CLAMPS, -17	900-217	900-247
ADEL CLAMPS, -19	900-219	900-249
ADEL CLAMPS, -20	900-220	900-250
NYLON CLAMPS, -3	-	900-253
NYLON CLAMPS, -9	-	900-269

## HOSE CLAMPS

- ★ SOLD IN BAGS OF 10
- ★ EACH STAINLESS STEEL CLAMP FITS SEVERAL DIFFERENT SIZES OF HOSE



DESCRIPTION	PART #
5/16" BAND, FITS 7/32" - 5/8" O.D. HOSE	940-205
5/16" BAND, FITS 5/16" - 7/8" O.D. HOSE	940-206
1/2" BAND, FITS 9/16" - 1 1/16" O.D. HOSE	940-207
1/2" BAND, FITS 9/16" - 1 1/4" O.D. HOSE	940-208
1/2" BAND, FITS 1 1/16" - 1 1/2" O.D. HOSE	940-209
1/2" BAND, FITS 3/4" - 1 3/4" O.D. HOSE	940-210
1/2" BAND, FITS 1 1/16" - 2" O.D. HOSE	940-211
1/2" BAND, FITS 1 5/16" - 2 1/4" O.D. HOSE	940-212
1/2" BAND, FITS 1 9/16" - 2 1/2" O.D. HOSE	940-213
1/2" BAND, FITS 1 13/16" - 2 3/4" O.D. HOSE	940-214
9/16" BAND, FITS 1 5/8" - 3 1/2" O.D. HOSE	940-215
9/16" BAND, FITS 3" - 5" O.D. HOSE	940-2174
9/16" BAND, FITS 2 1/2" - 4 1/2" O.D. HOSE	940-2179
9/16" BAND, FITS 5" - 7" O.D. HOSE	940-2182

Place your order at (479) 646-6988, Fax to (479) 646-5939, or visit [www.southwestspeed.com](http://www.southwestspeed.com)

# SCHOENFELD HEADERS - MODIFIED

## LONG TUBE STYLES FOR SMALL BLOCK CHEVY'S

- ★ FITS SMALL BLOCK CHEVY'S
- ★ LONGER PRIMARIES FOR MAXIMUM TORQUE & HORSEPOWER
- ★ FITS NUMEROUS POPULAR MODIFIED CHASSIS
- ★ GASKETS & BOLTS INCLUDED



TUBE DIAMETER	COLLECTOR DIA./LENGTH	STANDARD CHEVY	CRATE MOTOR	SPREAD PORT	CHEVY 18°
1 5/8"	3" x 8"	SCH 1185	SCH 1185CM		
1 5/8" - 1 3/4"	3 1/2" x 8"	SCH 1185V	SCH 1185VCM		
1 5/8" - 1 3/4"	3" x 8"	SCH 1185V-3	SCH 1185VCM-3		
1 3/4"	3 1/2" x 8"	SCH 1186	SCH 1186CM	SCH 1186SP	SCH 1186-18
1 3/4" - 1 7/8"	3 1/2" x 9"	SCH 1186V	SCH 1186VCM	SCH 1186VSP	SCH 1186V18

- ★ FITS SMALL BLOCK CHEVY'S
- ★ LONGER PRIMARIES FOR MAXIMUM TORQUE & HP
- ★ FITS NUMEROUS POPULAR MODIFIED CHASSIS
- ★ GASKETS & BOLTS INCLUDED

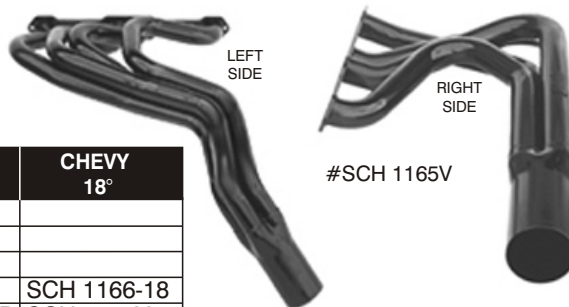

TUBE DIAMETER	COLLECTOR DIA./LENGTH	STANDARD CHEVY	CRATE MOTOR	SPREAD PORT	CHEVY 18°
1 5/8"	3" x 8"	SCH 1165	SCH 1165CM		
1 5/8" - 1 3/4"	3 1/2" x 8"	SCH 1165V	SCH 1165VCM		
1 5/8" - 1 3/4"	3" x 8"	SCH 1165V-3	SCH 1165VCM-3		
1 3/4"	3 1/2" x 8"	SCH 1166	SCH 1166CM	SCH 1166SP	SCH 1166-18
1 3/4" - 1 7/8"	3 1/2" x 9"	SCH 1166V	SCH 1166VCM	SCH 1166VSP	SCH 1166V18

- ★ LONGER PRIMARIES FOR MAXIMUM TORQUE & HP
- ★ FITS NUMEROUS POPULAR MODIFIED CHASSIS
- ★ FITS SBC; GASKETS & BOLTS INCLUDED

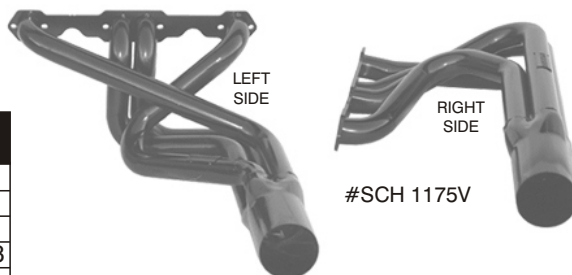

TUBE DIAMETER	COLLECTOR DIA./LENGTH	STANDARD CHEVY	SPREAD PORT	CHEVY 18°
1 5/8" - 1 3/4"	3 1/2" x 8"	SCH 1175V		
1 5/8" - 1 3/4"	3" x 8"	SCH 1175V-3		
1 3/4"	3 1/2" x 8"	SCH 1176	SCH 1176SP	SCH 1176-18
1 3/4" - 1 7/8"	3 1/2" x 9"	SCH 1176V	SCH 1176VSP	SCH 1176V18
1 7/8"	3 1/2" x 9"	SCH 1177	SCH 1177SP	SCH 1177-18

- ★ FITS SMALL BLOCK CHEVY'S
- ★ LONGER PRIMARIES FOR MAXIMUM TORQUE & HORSEPOWER
- ★ FITS NUMEROUS POPULAR MODIFIED CHASSIS
- ★ GASKETS & BOLTS INCLUDED

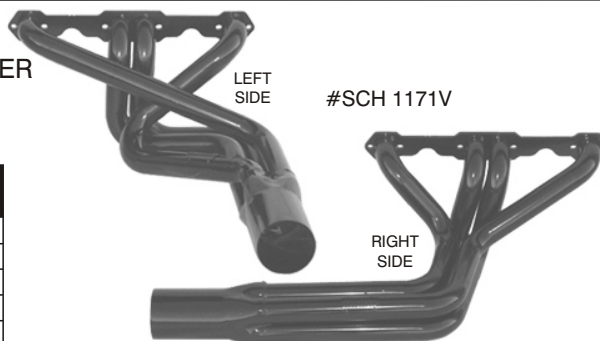

TUBE DIAMETER	COLLECTOR DIA./LENGTH	STANDARD CHEVY	SPREAD PORT	CHEVY 18°
1 5/8" - 1 3/4"	3 1/2" x 8"	SCH 1171V		
1 5/8" - 1 3/4"	3" x 8"	SCH 1171V-3		
1 3/4"	3 1/2" x 8"	SCH 1172	SCH 1172SP	SCH 1172-18
1 3/4" - 1 7/8"	3 1/2" x 9"	SCH 1172V	SCH 1172VSP	SCH 1172V18
1 7/8"	3 1/2" x 9"	SCH 1173	SCH 1173SP	SCH 1173-18

- ★ LONGER PRIMARIES FOR MAXIMUM TORQUE & HORSEPOWER
- ★ FITS NUMEROUS POPULAR MODIFIED CHASSIS
- ★ FITS SBC; GASKETS & BOLTS INCLUDED



TUBE DIAMETER	COLLECTOR DIA./LENGTH	STANDARD CHEVY	SPREAD PORT	CHEVY 18°
1 3/4"	3 1/2" x 8"	SCH 1146		
1 3/4" - 1 7/8"	3 1/2" x 9"	SCH 1146V	SCH 1146VSP	SCH 1146V18

\*NOTE: IF YOU ARE UNSURE WHICH STYLE OF HEADER FITS YOUR PARTICULAR CAR, CONSULT THE SCHOENFELD HEADERS CATALOG OR VISIT [WWW.SCHOENFELDHEADERS.COM](http://WWW.SCHOENFELDHEADERS.COM) FOR A MORE DETAILED DESCRIPTION

Place your order at (479) 646-6988, Fax to (479) 646-5939, or visit [www.southwestspeed.com](http://www.southwestspeed.com)



# SCHOENFELD HEADERS - MODIFIED

## LONG TUBE STYLES FOR SMALL BLOCK CHEVY'S

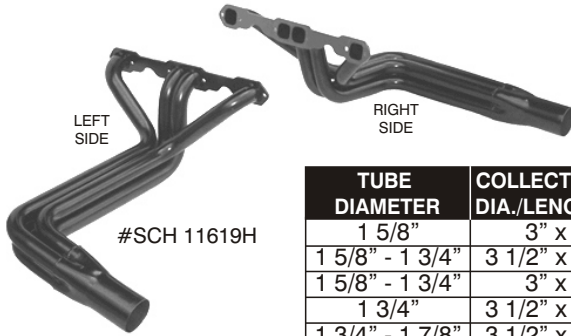

- ★ FITS SMALL BLOCK CHEVY'S
- ★ LONGER PRIMARIES FOR MAXIMUM TORQUE & HORSEPOWER
- ★ FITS NUMEROUS POPULAR MODIFIED CHASSIS
- ★ GASKETS & BOLTS INCLUDED

TUBE DIAMETER	COLLECTOR DIA./LENGTH	STANDARD CHEVY	CRATE MOTOR	SPREAD PORT	CHEVY 18°
1 5/8"	3" x 8"	SCH 11619H	SCH 11619HCM		
1 5/8" - 1 3/4"	3 1/2" x 8"	SCH 1161V9H	SCH 1161V9HCM		
1 5/8" - 1 3/4"	3" x 8"	SCH 1161V9H-3	SCH 1161V9HCM-3		
1 3/4"	3 1/2" x 8"	SCH 11629H	SCH 11629HCM	SCH 11629HSP	SCH 11629H18
1 3/4" - 1 7/8"	3 1/2" x 9"	SCH 1162V9H	SCH 1162V9HCM	SCH 1162V9HSP	SCH 1162V9H18

- ★ LONGER PRIMARIES FOR MAXIMUM TORQUE & HORSEPOWER
- ★ FITS NUMEROUS POPULAR MODIFIED CHASSIS
- ★ FITS SBC; GASKETS & BOLTS INCLUDED



TUBE DIAMETER	COLLECTOR DIA./LENGTH	STANDARD CHEVY	SPREAD PORT	CHEVY 18°
1 3/4"	3 1/2" x 8"	SCH 1152	SCH 1152SP	SCH 1152-18
1 3/4" - 1 7/8"	3 1/2" x 9"	SCH 1152V	SCH 1152VSP	SCH 1152V18

## MID-LENGTH PRIMARY STYLE FOR SMALL BLOCK CHEVY'S

- ★ FITS SMALL BLOCK CHEVY'S & NUMEROUS POPULAR MODIFIED CHASSIS
- ★ GASKETS & BOLTS INCLUDED

TUBE DIAMETER	COLLECTOR DIA./LENGTH	STANDARD CHEVY	CRATE MOTOR	SPREAD PORT	CHEVY 18°
1 5/8"	3" x 8"	SCH 1105	SCH 1105CM		
1 5/8" - 1 3/4"	3 1/2" x 8"	SCH 1105V	SCH 1105VCM		
1 5/8" - 1 3/4"	3" x 8"	SCH 1105V-3	SCH 1105VCM-3		
1 3/4"	3 1/2" x 8"	SCH 1106	SCH 1106CM	SCH 1106SP	SCH 1106-18
1 3/4" - 1 7/8"	3 1/2" x 9"	SCH 1106V	SCH 1106VCM	SCH 1106VSP	SCH 1106V18

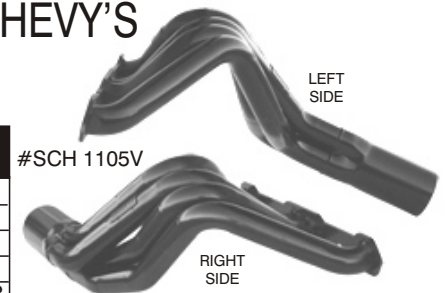

## MODIFIED TRI-Y HEADERS

- ★ 4 INTO 2 INTO 1 CONFIGURATION FOR INCREASED TORQUE
- ★ FITS SMALL BLOCK CHEVY'S
- ★ LONGER PRIMARIES FOR MAXIMUM TORQUE & HORSEPOWER
- ★ FITS NUMEROUS POPULAR MODIFIED CHASSIS
- ★ GASKETS & BOLTS INCLUDED

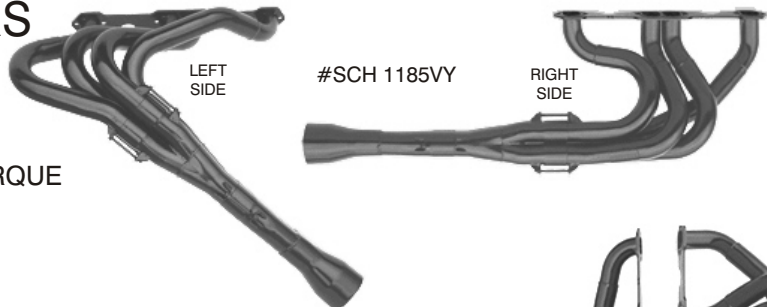

TUBE DIAMETER	COLLECTOR DIAMETER	STANDARD CHEVY	SPREAD PORT
1 5/8" - 1 3/4"	3"	SCH 1185VY	
1 3/4" - 1 7/8"	3 1/2"	SCH 1186VY	SCH 1186VYSP

TUBE DIAMETER	COLLECTOR DIAMETER	STANDARD CHEVY	SPREAD PORT
1 5/8" - 1 3/4"	3"	SCH 1195VY	
1 3/4" - 1 7/8"	3 1/2"	SCH 1196VY	SCH 1196VYSP

TUBE DIAMETER	COLLECTOR DIAMETER	STANDARD CHEVY	SPREAD PORT
1 3/4" - 1 7/8"	3 1/2"	SCH 1162VY	SCH 1162VYSP

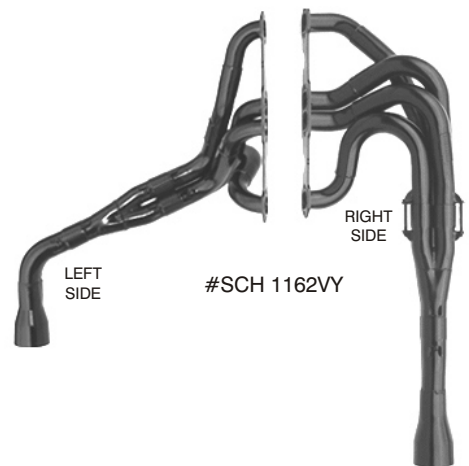

\*NOTE: IF YOU ARE UNSURE WHICH STYLE OF HEADER FITS YOUR PARTICULAR CAR, CONSULT THE SCHOENFELD HEADERS CATALOG OR VISIT [WWW.SCHOENFELDHEADERS.COM](http://WWW.SCHOENFELDHEADERS.COM) FOR A MORE DETAILED DESCRIPTION

Place your order at (479) 646-6988, Fax to (479) 646-5939, or visit [www.southwestspeed.com](http://www.southwestspeed.com)

# SCHOENFELD HEADERS - MODIFIED

## FOR SMALL BLOCK CHEVY'S

- ★ FITS SBC'S & MOST MODIFIED CHASSIS
- ★ NORMAL LENGTH PRIMARIES; GASKETS & BOLTS INCLUDED

TUBE DIAMETER	COLLECTOR DIA./LENGTH	STANDARD CHEVY	CRATE MOTOR	SPREAD PORT	CHEVY 18°
1 1/2"	3" x 8"	SCH 160			
1 5/8"	3" x 8"	SCH 161	SCH 161CM		
1 5/8" - 1 3/4"	3 1/2" x 8"	SCH 161V	SCH 161VCM		
1 3/4"	3 1/2" x 8"	SCH 162	SCH 162CM	SCH 162SP	SCH 162-18
1 7/8"	3 1/2" x 9"	SCH 163	SCH 163CM	SCH 163SP	SCH 163-18



- ★ FITS SMALL BLOCK CHEVY'S & MOST MODIFIED CHASSIS
- ★ NORMAL LENGTH PRIMARIES; GASKETS & BOLTS INCLUDED

TUBE DIAMETER	COLLECTOR DIA./LENGTH	STANDARD CHEVY	SPREAD PORT	CHEVY 18°
1 5/8"	3" x 8"	SCH 171		
1 5/8" - 1 3/4"	3 1/2" x 8"	SCH 171V		
1 3/4"	3 1/2" x 8"	SCH 172	SCH 172SP	SCH 172-18
1 3/4" - 1 7/8"	3 1/2" x 9"	SCH 172V	SCH 172VSP	SCH 172V18
1 7/8"	3 1/2" x 9"	SCH 173	SCH 173SP	SCH 173-18

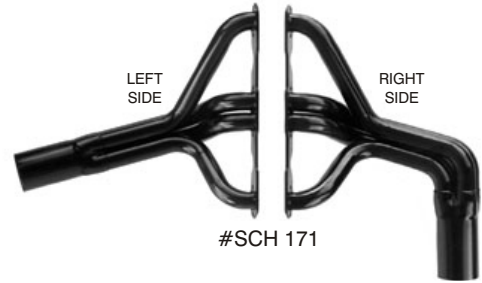

- ★ FITS SMALL BLOCK CHEVY'S & MOST MODIFIED CHASSIS
- ★ NORMAL LENGTH PRIMARIES; GASKETS & BOLTS INCLUDED

TUBE DIAMETER	COLLECTOR DIA./LENGTH	STANDARD CHEVY	SPREAD PORT	CHEVY 18°
1 5/8"	3" x 8"	SCH 175		
1 5/8" - 1 3/4"	3 1/2" x 8"	SCH 175V		
1 3/4"	3 1/2" x 8"	SCH 176	SCH 176SP	SCH 176-18
1 3/4" - 1 7/8"	3 1/2" x 9"	SCH 176V	SCH 176VSP	SCH 176V18
1 7/8"	3 1/2" x 9"	SCH 177	SCH 177SP	SCH 177-18

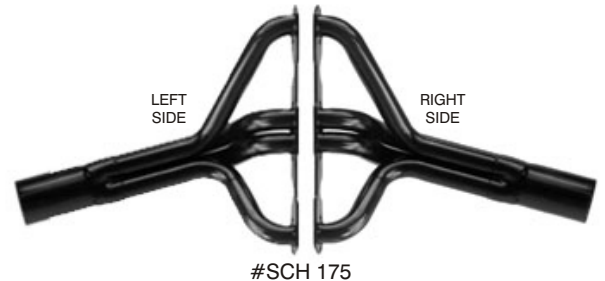

## SHORT TUBE STYLE FOR SMALL BLOCK CHEVY'S

- ★ FITS SMALL BLOCK CHEVY'S & MOST MODIFIED CHASSIS
- ★ SHORTER PRIMARIES INCREASE FLAT TORQUE RANGE WITH CRISP THROTTLE RESPONSE

TUBE DIAMETER	COLLECTOR DIA./LENGTH	STANDARD CHEVY	SPREAD PORT	CHEVY 18°
1 5/8"	3" x 8"	SCH 161B		
1 3/4"	3 1/2" x 8"	SCH 162B	SCH 162BSP	SCH 162B-18
1 7/8"	3 1/2" x 9"	SCH 163B	SCH 163BSP	SCH 163B-18

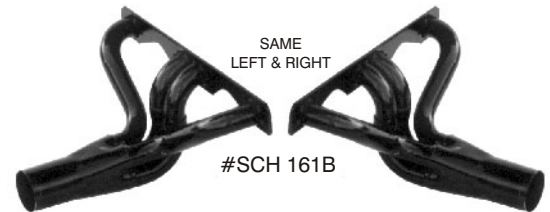

## SHORT TUBE "LITE SERIES" FOR SBC'S

- ★ LIGHTWEIGHT HEADERS (20 GAUGE TUBING) WITH LIGHTWEIGHT LASER CUT FLANGES
- ★ FITS SMALL BLOCK CHEVY'S & MOST MODIFIED CHASSIS
- ★ SHORTER PRIMARIES INCREASE FLAT TORQUE RANGE WITH CRISP THROTTLE RESPONSE; GASKETS & BOLTS INCLUDED

TUBE DIAMETER	COLLECTOR DIA./LENGTH	STANDARD CHEVY	SPREAD PORT	CHEVY 18°
1 3/4"	3 1/2" x 8"	SCH 162BT	SCH 162BTSP	SCH 162BT18
1 7/8"	3 1/2" x 9"	SCH 163BT	SCH 163BTSP	SCH 163BT18

TUBE DIAMETER	COLLECTOR DIA./LENGTH	STANDARD CHEVY	SPREAD PORT	CHEVY 18°
1 3/4"	3 1/2" x 8"	SCH 172T	SCH 172SPT	SCH 172-18T
1 7/8"	3 1/2" x 9"	SCH 173T	SCH 173SPT	SCH 173-18T

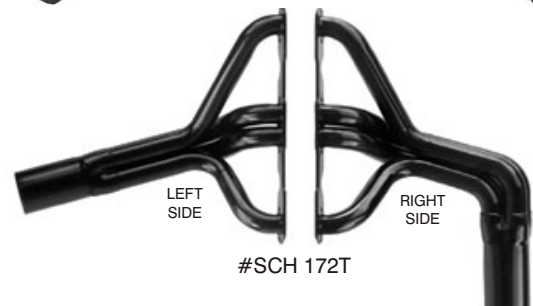
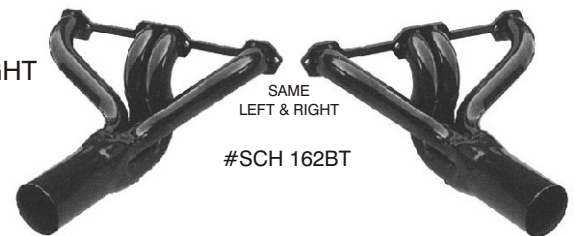

\*IF YOU ARE UNSURE WHICH STYLE OF HEADER FITS YOUR PARTICULAR CAR, CONSULT THE SCHOENFELD HEADERS CATALOG OR VISIT [WWW.SCHOENFELDHEADERS.COM](http://WWW.SCHOENFELDHEADERS.COM) FOR A MORE DETAILED DESCRIPTION

Place your order at (479) 646-6988, Fax to (479) 646-5939, or visit [www.southwestspeed.com](http://www.southwestspeed.com)

# SCHOENFELD HEADERS - MODIFIED - ADJUSTABLE

LEFT SIDE COLLECTORS

RIGHT SIDE COLLECTORS

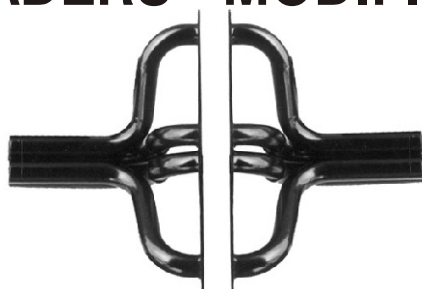

HOW TO DETERMINE YOUR NUMBER

ENGINE TYPE	HEADER STYLE	TUBE DIAMETER	LEFT COLL. STYLE	RIGHT COLL. TYPE
-------------	--------------	---------------	------------------	------------------

1 6 1 - 6 8

## SMALL BLOCK CHEVY

TUBE DIAMETER	COLLECTOR DIA./LENGTH	FLANGE	LEFT: STYLE 3 RIGHT: STYLE 8	LEFT: STYLE 6 RIGHT: STYLE 8	LEFT: STYLE 9 RIGHT: STYLE 8	LEFT: STYLE 9H RIGHT: STYLE 8
1 1/2" - 1 5/8"	3" x 8"	STANDARD	SCH 160-38	SCH 160-68	SCH 160-98	SCH 160-98H
1 5/8" - 1 3/4"	3" x 8"	STANDARD	SCH 161-38	SCH 161-68	SCH 161-98	SCH 161-98H
1 3/4" - 1 7/8"	3 1/2" x 9"	STANDARD	SCH 162-38	SCH 162-68	SCH 162-98	SCH 162-98H
1 3/4" - 1 7/8"	3 1/2" x 9"	SPRD PORT	SCH 162-38SP	SCH 162-68SP	SCH 162-98SP	SCH 162-98HSP
1 3/4" - 1 7/8"	3 1/2" x 9"	18° CHEVY	SCH 162-38-18	SCH 162-68-18	SCH 162-98-18	SCH 162-98H-18
1 7/8" - 2"	3 1/2" x 9"	STANDARD	SCH 163-38	SCH 163-68	SCH 163-98	SCH 163-98H

\*ALSO AVAILABLE WITH A 3 LEFT & 9 RIGHT, A 8 LEFT & 8 RIGHT, A 9 LEFT & 9 RIGHT, A 9 LEFT & 9H RIGHT. JUST ASK FOR DETAILS.

## BIG BLOCK CHEVY

TUBE DIAMETER	COLLECTOR DIA./LENGTH	FLANGE	LEFT: STYLE 3 RIGHT: STYLE 8	LEFT: STYLE 6 RIGHT: STYLE 8	LEFT: STYLE 9 RIGHT: STYLE 8	LEFT: STYLE 9H RIGHT: STYLE 8
1 3/4" - 1 7/8"	3 1/2" x 9"	STANDARD	SCH 262-38	SCH 262-68	SCH 262-98	SCH 262-98H
1 7/8" - 2"	3 1/2" x 9"	STANDARD	SCH 263-38	SCH 263-68	SCH 263-98	SCH 263-98H

## SMALL BLOCK FORD

TUBE DIAMETER	COLLECTOR DIA./LENGTH	FLANGE	LEFT: STYLE 3 RIGHT: STYLE 8	LEFT: STYLE 6 RIGHT: STYLE 8	LEFT: STYLE 9 RIGHT: STYLE 8	LEFT: STYLE 9H RIGHT: STYLE 8
1 5/8" - 1 3/4"	3" x 8"	WINDSOR	SCH 361-38	SCH 361-68	SCH 361-98	SCH 361-98H
1 3/4" - 1 7/8"	3 1/2" x 9"	WINDSOR	SCH 362-38	SCH 362-68	SCH 362-98	SCH 362-98H
1 5/8" - 1 3/4"	3" x 8"	*DART/"N"	SCH 361-38N	SCH 361-68N	SCH 361-98N	SCH 361-98HN
1 3/4" - 1 7/8"	3 1/2" x 9"	*DART/"N"	SCH 362-38N	SCH 362-68N	SCH 362-98N	SCH 362-98HN
1 3/4" - 1 7/8"	3 1/2" x 9"	CLEVELAND	SCH 562-38	SCH 562-68	SCH 562-98	SCH 562-98H
1 3/4" - 1 7/8"	3 1/2" x 9"	SVO (ALUM.)	SCH 662-38	SCH 662-68	SCH 662-98	SCH 662-98H

\*DART/"N" FLANGE FITS THE WIDE DART BOLT PATTERN & SPORTSMAN "N" HEAD

NOTE: PLEASE SPECIFY A 4 BARREL CLEVELAND FLANGE

## SMALL BLOCK MOPAR

TUBE DIAMETER	COLLECTOR DIA./LENGTH	FLANGE	LEFT: STYLE 3 RIGHT: STYLE 8	LEFT: STYLE 6 RIGHT: STYLE 8	LEFT: STYLE 9 RIGHT: STYLE 8	LEFT: STYLE 9H RIGHT: STYLE 8
1 5/8" - 1 3/4"	3" x 8"	STANDARD	SCH 461-38	SCH 461-68	SCH 461-98	SCH 461-98H
1 3/4" - 1 7/8"	3 1/2" x 9"	STANDARD	SCH 462-38	SCH 462-68	SCH 462-98	SCH 462-98H
1 5/8" - 1 3/4"	3" x 8"	*W-2	SCH 461-38W2	SCH 461-68W2	SCH 461-98W2	SCH 461-98HW2
1 3/4" - 1 7/8"	3 1/2" x 9"	*W-2	SCH 462-38W2	SCH 462-68W2	SCH 462-98W2	SCH 462-98HW2

\*FOR W-2 FLANGES, PLEASE SPECIFY 4" OR 4 3/4" SPREAD ON THE CENTER BOLTS

NOTE: COLLECTORS ARE SLIP-ON TO ADJUST FOR ENGINE LOCATION

## ADJUSTABLE ROTATED COLLECTORS FOR SBC'S

★ FITS NUMEROUS POPULAR MODIFIED CHASSIS

★ BOTH COLLECTORS ARE ROTATED AT A 45° ANGLE DOWN

TUBE DIAMETER	COLLECTOR DIA./LENGTH	STANDARD CHEVY	SPREAD PORT	CHEVY 18°
1 5/8" - 1 3/4"	3" x 8"	SCH 161-68R	SCH 161-68RSP	
1 3/4" - 1 7/8"	3 1/2" x 9"	SCH 162-68R	SCH 162-68RSP	SCH 162-68R18

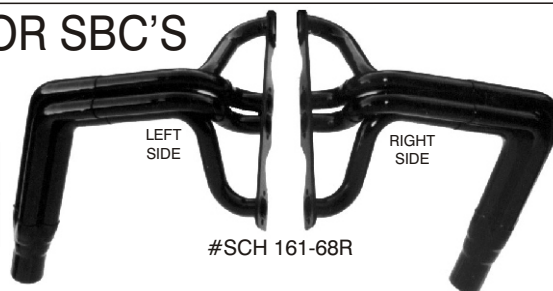

Place your order at (479) 646-6988, Fax to (479) 646-5939, or visit [www.southwestspeed.com](http://www.southwestspeed.com)



# SCHOENFELD HEADERS - MODIFIED FOR SBC SB2

- ★ FITS CHEVY SB2'S
- ★ FITS MOST MODIFIED CHASSIS
- ★ GASKETS & BOLTS INCLUDED



TUBE DIAMETER	COLLECTOR DIA./LENGTH	CHEVY SB2
1 3/4" - 1 7/8"	3 1/2" x 9"	SCH 172VSB2

## FOR CHEVY V-6

- ★ FITS V-6 CHEVY'S
- ★ REGULAR & SHORTENED PRIMARIES AVAILABLE
- ★ FITS MOST MODIFIED CHASSIS
- ★ GASKETS & BOLTS INCLUDED



TUBE DIAMETER	COLLECTOR DIA./LENGTH	NORMAL PRIMARIES	SHORT PRIMARIES
1 5/8"	3" x 8"	SCH 8361	SCH 8361B
1 3/4"	3" x 8"	SCH 8362	SCH 8362B
1 5/8" - 1 3/4"	3" x 8"	SCH 8361-68	
1 3/4" - 1 7/8"	3" x 8"	SCH 8362-68	

## FOR BIG BLOCK CHEVY'S

- ★ FITS BIG BLOCK CHEVY'S
- ★ FITS MOST MODIFIED CHASSIS
- ★ GASKETS & BOLTS INCLUDED

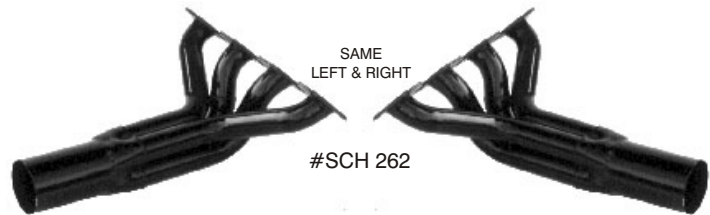

TUBE DIAMETER	COLLECTOR DIA./LENGTH	BIG BLOCK CHEVY
1 3/4"	3 1/2" x 8"	SCH 262
1 7/8"	3 1/2" x 9"	SCH 263

## FOR FORD'S

- ★ FITS FORD'S & MOST MODIFIED CHASSIS
- ★ GASKETS & BOLTS INCLUDED

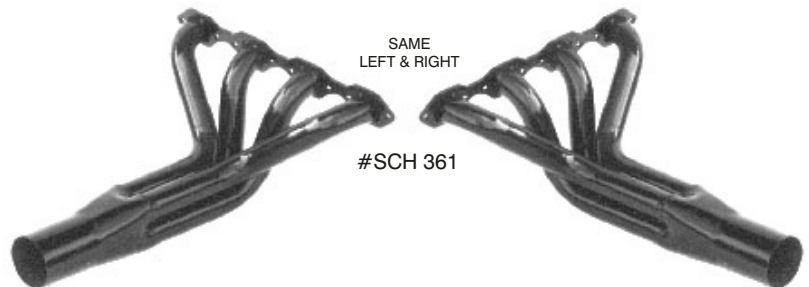

TUBE DIAMETER	COLLECTOR DIA./LENGTH	WINDSOR	DART/"N" HEAD
1 5/8"	3" x 8"	SCH 361	SCH 361N
1 3/4"	3 1/2" x 8"	SCH 362	SCH 362N

TUBE DIAMETER	COLLECTOR DIA./LENGTH	CLEVELAND 2 BARREL	CLEVELAND 4 BARREL
1 3/4"	3 1/2" x 8"	SCH 562	SCH 562-4B

## FOR MOPAR'S

- ★ FITS MOPAR'S
- ★ FITS MOST MODIFIED CHASSIS
- ★ GASKETS & BOLTS INCLUDED

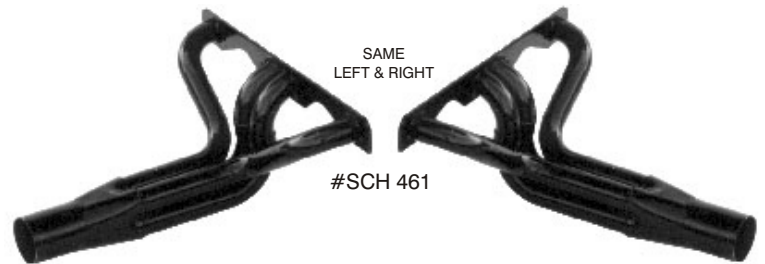

TUBE DIAMETER	COLLECTOR DIA./LENGTH	STANDARD 318-340-360	W-2*
1 5/8"	3" x 8"	SCH 461	SCH 461-W2*
1 3/4"	3 1/2" x 8"	SCH 462	SCH 462-W2*

\*FOR W-2 FLANGES, PLEASE SPECIFY 4" OR 4 3/4" SPREAD ON THE CENTER BOLTS

\*NOTE: IF YOU ARE UNSURE WHICH STYLE OF HEADER FITS YOUR PARTICULAR CAR, CONSULT THE SCHOENFELD HEADERS CATALOG OR VISIT [WWW.SCHOENFELDHEADERS.COM](http://WWW.SCHOENFELDHEADERS.COM) FOR A MORE DETAILED DESCRIPTION

Place your order at (479) 646-6988, Fax to (479) 646-5939, or visit [www.southwestspeed.com](http://www.southwestspeed.com)

# SCHOENFELD HEADERS - MODIFIED

## LONG TUBE STYLES FOR SBC LS1-LS7

- ★ FITS CHEVY LS1 - LS7
- ★ LONGER PRIMARIES FOR MAXIMUM TORQUE & HORSEPOWER
- ★ FITS NUMEROUS POPULAR MODIFIED CHASSIS
- ★ GASKETS & BOLTS INCLUDED

TUBE DIAMETER	COLLECTOR DIA./LENGTH	CHEVY LS1-LS7
1 5/8" - 1 3/4"	3 1/2" x 8"	SCH 1185VLS1
1 5/8" - 1 3/4"	3" x 8"	SCH 1185VLS1-3
1 3/4"	3 1/2" x 8"	SCH 1186LS1
1 3/4" - 1 7/8"	3 1/2" x 9"	SCH 1186VLS1

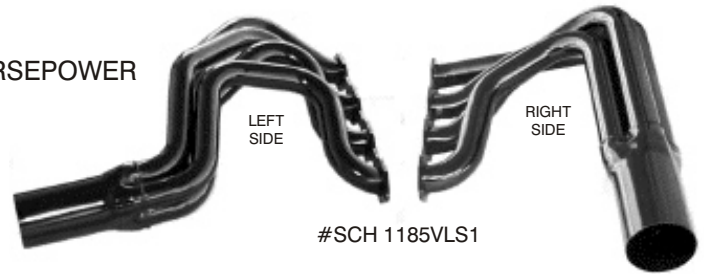

## LONG TUBE STYLES FOR CHEVY SB2

- ★ FITS CHEVY SB2'S
- ★ LONGER PRIMARIES FOR MAXIMUM TORQUE & HORSEPOWER
- ★ FITS NUMEROUS POPULAR MODIFIED CHASSIS
- ★ GASKETS & BOLTS INCLUDED

TUBE DIAMETER	COLLECTOR DIA./LENGTH	CHEVY SB2
1 3/4" - 1 7/8"	3 1/2" x 9"	SCH 1186VSB2

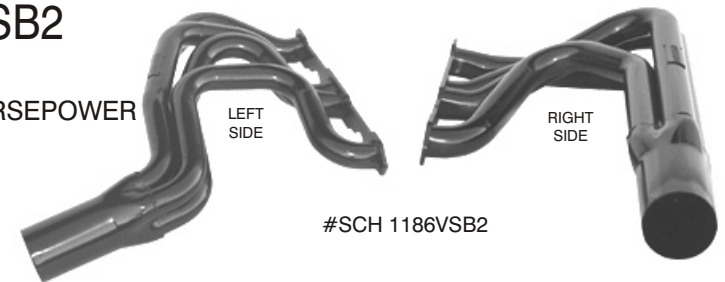

## LONG TUBE STYLES FOR FORD'S

- ★ LONGER PRIMARIES FOR MAXIMUM TORQUE & HORSEPOWER
- ★ FITS FORD'S & NUMEROUS POPULAR MODIFIED CHASSIS; GASKETS & BOLTS INCLUDED

TUBE DIAMETER	COLLECTOR DIA./LENGTH	WINDSOR	DART/"N" HEAD
1 5/8" - 1 3/4"	3 1/2" x 8"	SCH 3185V	SCH 3185VN
1 5/8" - 1 3/4"	3" x 8"	SCH 3185V-3	SCH 3185VN-3
1 3/4"	3 1/2" x 8"	SCH 3186	SCH 3186N
1 3/4" - 1 7/8"	3 1/2" x 9"	SCH 3186V	SCH 3186VN

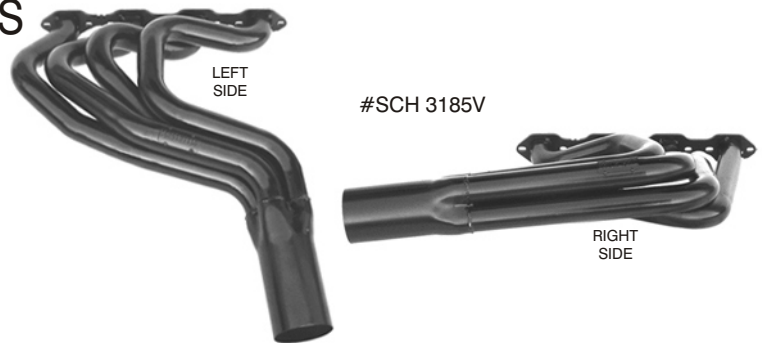

## MID-LENGTH PRIMARY STYLE FOR FORD'S

- ★ FITS FORD'S & NUMEROUS POPULAR MODIFIED CHASSIS
- ★ GASKETS & BOLTS INCLUDED

TUBE DIAMETER	COLLECTOR DIA./LENGTH	289-302-351	DART/"N" HEAD
1 5/8"	3" x 8"	SCH 3105	SCH 3105N
1 5/8" - 1 3/4"	3 1/2" x 8"	SCH 3105V	SCH 3105VN
1 5/8" - 1 3/4"	3" x 8"	SCH 3105V-3	SCH 3105VN-3
1 3/4"	3 1/2" x 8"	SCH 3106	SCH 3106N
1 3/4" - 1 7/8"	3 1/2" x 9"	SCH 3106V	SCH 3106VN



## TURNOUTS

- ★ EXPANDED ON ONE END
- ★ SLIP-ON DESIGN WITH A CLEAN, FINISHED LOOK
- ★ DEFLECTS EXHAUST



DIA.	PART #
2 1/2"	SCH 2525
3"	SCH 3025
3 1/2"	SCH 3525

## MODIFIED MUFFLERS

- ★ REMOVES 9 DECIBELS OF SOUND
- ★ MUFFLER SLIDES INTO 3" OR 3 1/2" COLLECTORS



DIAMETER	WEIGHT	PART #
6"	1.28#	SCH 609

\*NOTE: IF YOU ARE UNSURE WHICH STYLE OF HEADER FITS YOUR PARTICULAR CAR, CONSULT THE SCHOENFELD HEADERS CATALOG OR VISIT [WWW.SCHOENFELDHEADERS.COM](http://WWW.SCHOENFELDHEADERS.COM) FOR A MORE DETAILED DESCRIPTION

Place your order at (479) 646-6988, Fax to (479) 646-5939, or visit [www.southwestspeed.com](http://www.southwestspeed.com)

# SCHOENFELD HEADERS - CHEVY STOCK CLIP

- ★ FITS SBC; FITS STRAIGHT OR ANGLE PLUG HEADS
- ★ EXITS OVER FRAME RAIL ON BOTH SIDES
- ★ WILL NOT FIT WITH STOCK FIREWALL; GASKETS & BOLTS INCLUDED

TUBE DIAMETER	COLLECTOR DIA./LENGTH	STANDARD CHEVY	CRATE MOTOR
1 1/2" - 1 5/8"	3" x 8"	SCH 154V	
1 5/8"	3" x 8"	SCH 155	SCH 155CM
1 5/8" - 1 3/4"	3 1/2" x 8"	SCH 155V	SCH 155VCM
1 5/8" - 1 3/4"	3" x 8"	SCH 155V-3	SCH 155VCM-3
1 3/4"	3 1/2" x 8"	SCH 156	SCH 156CM
1 3/4"	3" x 8"	SCH 156-3	SCH 156CM-3
1 3/4" - 1 7/8"	3 1/2" x 8"	SCH 156V	SCH 156VCM



- ★ FITS SBC; FITS STRAIGHT OR ANGLE PLUG HEADS
- ★ EXITS OVER FRAME RAIL ON BOTH SIDES
- ★ WILL NOT FIT WITH STOCK FIREWALL; GASKETS & BOLTS INCLUDED

TUBE DIAMETER	COLLECTOR DIA./LENGTH	STANDARD CHEVY	SPREAD PORT
1 1/2" - 1 5/8"	3" x 8"	SCH 120V	
1 5/8"	3" x 8"	SCH 121	
1 5/8" - 1 3/4"	3 1/2" x 8"	SCH 121V	
1 5/8" - 1 3/4"	3" x 8"	SCH 121V-3	
1 3/4"	3 1/2" x 8"	SCH 122	SCH 122SP
1 3/4"	3" x 8"	SCH 122-3	SCH 122SP-3
1 3/4" - 1 7/8"	3 1/2" x 8"	SCH 122V	SCH 122VSP

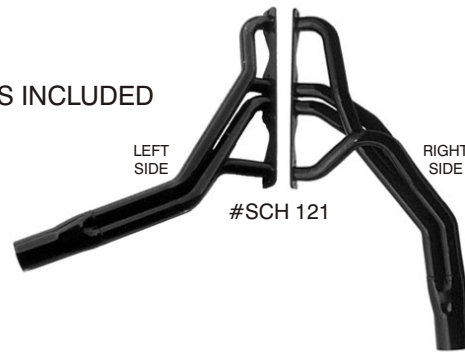

- ★ FITS SBC; FITS STRAIGHT OR ANGLE PLUG HEADS
- ★ EXITS OVER FRAME RAIL ON BOTH SIDES
- ★ WILL NOT FIT WITH STOCK FIREWALL OR STOCK A-FRAME

TUBE DIAMETER	COLLECTOR DIA./LENGTH	STANDARD CHEVY	SPREAD PORT
1 1/2" - 1 5/8"	3" x 8"	SCH 124V	
1 5/8"	3" x 8"	SCH 125	
1 5/8" - 1 3/4"	3 1/2" x 8"	SCH 125V	
1 5/8" - 1 3/4"	3" x 8"	SCH 125V-3	
1 3/4"	3 1/2" x 8"	SCH 126	SCH 126SP
1 3/4"	3" x 8"	SCH 126-3	SCH 126SP-3
1 3/4" - 1 7/8"	3 1/2" x 8"	SCH 126V	SCH 126VSP

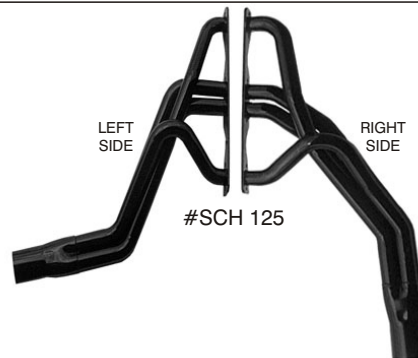

## STOCK CLIP HEADERS SPECIFICALLY FOR CAMARO'S & METRIC'S

- ★ DESIGNED TO ELIMINATE CLEARANCE PROBLEMS ON 1970-81 CAMARO'S & 1978-82 METRIC CARS
- ★ THE OVER-THE-FRAME STYLE HEADER, WHICH EXITS OUT AT MID-FENDER, FITS THE STOCK FIREWALL & UPPER A-FRAMES WITH THE ENGINE IN THE FACTORY LOCATION
- ★ ELIMINATES STARTER, OIL PAN, OIL FILTER, SPARK PLUG, & GROUND

### 1970-81 CAMARO STOCK CLIP

TUBE DIAMETER	COLLECTOR DIA./LENGTH	STANDARD CHEVY	CRATE MOTOR
1 5/8"	3" x 8"	SCH 103	SCH 103CM
1 5/8" - 1 3/4"	3 1/2" x 8"	SCH 103V	SCH 103VCM
1 5/8" - 1 3/4"	3" x 8"	SCH 103V-3	SCH 103VCM-3
1 3/4"	3 1/2" x 8"	SCH 104	SCH 104CM
1 3/4"	3" x 8"	SCH 104-3	SCH 104CM-3
1 3/4" - 1 7/8"	3 1/2" x 9"	SCH 104V	SCH 104VCM

CLEARANCE PROBLEMS

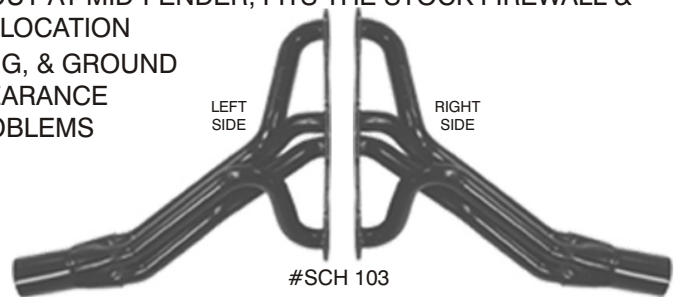

### 1978-82 METRIC STOCK CLIP

TUBE DIAMETER	COLLECTOR DIA./LENGTH	STANDARD CHEVY	CRATE MOTOR
1 5/8"	3" x 8"	SCH 107	SCH 107CM
1 5/8" - 1 3/4"	3 1/2" x 8"	SCH 107V	SCH 107VCM
1 5/8" - 1 3/4"	3" x 8"	SCH 107V-3	SCH 107VCM-3
1 3/4"	3 1/2" x 8"	SCH 108	SCH 108CM
1 3/4"	3" x 8"	SCH 108-3	SCH 108CM-3
1 3/4" - 1 7/8"	3 1/2" x 9"	SCH 108V	SCH 108VCM

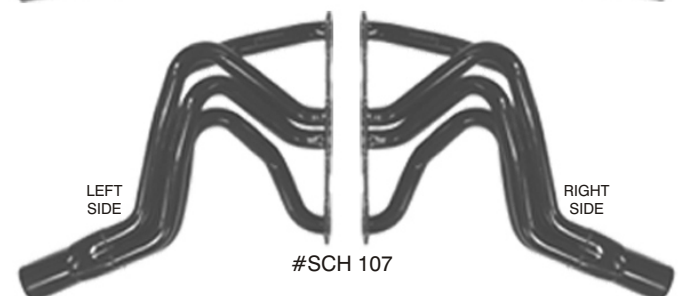

Place your order at (479) 646-6988, Fax to (479) 646-5939, or visit [www.southwestspeed.com](http://www.southwestspeed.com)



# SCHOENFELD HEADERS - STREET STOCK

1972-87 MONTE CARLO, 1978-87 MALIBU, PONTIAC GRAND PRIX, OLDS CUTLASS, & BUICK REGAL, AND 1970-81 CAMARO

- ★ CLEARS SOLID SIDE & REAR ENGINE MOUNTS
- ★ MOTOR MUST BE IN STOCK LOCATION
- ★ WILL FIT STRAIGHT & ANGLE PLUG HEADS
- ★ WILL NOT CLEAR STOCK MANUAL CLUTCH LINKAGE BALL LOCATED BEHIND THE #7 CYLINDER
- ★ WILL NOT FIT WITH SOME MINI-STARTERS
- ★ WILL NOT FIT SOME KICK-OUT OIL PANS
- ★ WILL NOT CLEAR AIR-CONDITIONER BOX
- ★ MUST USE SHORT OIL FILTER, SUCH AS #WFP 51069R (SEE PAGE 85)
- ★ GASKETS & BOLTS INCLUDED



TUBE DIAMETER	COLLECTOR DIA./LENGTH	STANDARD CHEVY	CRATE MOTOR	SPREAD PORT	CHEVY 18°
1 1/2" - 1 5/8"	3" x 8"	SCH 184V			
1 5/8"	3" x 8"	SCH 185	SCH 185CM		
1 5/8" - 1 3/4"	3" x 8"	SCH 185V	SCH 185VCM		
1 3/4"	3 1/2" x 8"	SCH 186	SCH 186CM	SCH 186SP	SCH 186-18
1 3/4"	3" x 8"	SCH 186-3	SCH 186CM-3	SCH 186SP-3	SCH 186-18-3
1 3/4" - 1 7/8"	3 1/2" x 9"	SCH 186V	SCH 186VCM	SCH 186VSP	SCH 186V18
1 7/8"	3 1/2" x 9"	SCH 187		SCH 187SP	SCH 187-18

1972-87 MONTE CARLO, 1978-87 MALIBU, OLDS CUTLASS, BUICK REGAL, & PONTIAC GRAND PRIX, AND 1970-81 CAMARO



- ★ CLEARS SOLID SIDE & REAR ENGINE MOUNTS
- ★ WILL FIT STRAIGHT & ANGLE PLUG HEADS
- ★ WILL CLEAR STOCK MANUAL CLUTCH LINKAGE BALL
- ★ WILL NOT CLEAR AIR-CONDITIONER BOX
- ★ MUST USE SHORT OIL FILTER, SUCH AS #WFP 51069R
- ★ GASKETS & BOLTS INCLUDED

TUBE DIAMETER	COLLECTOR DIA./LENGTH	STANDARD CHEVY	CRATE MOTOR
1 1/2" - 1 5/8"	3" x 8"	SCH 184VM	
1 5/8"	3" x 8"	SCH 185M	SCH 185MCM
1 5/8" - 1 3/4"	3" x 8"	SCH 185VM	SCH 185VMCM
1 3/4"	3 1/2" x 8"	SCH 186M	SCH 186MCM
1 3/4"	3" x 8"	SCH 186M-3	SCH 186MCM-3
1 3/4" - 1 7/8"	3 1/2" x 9"	SCH 186VM	SCH 186VMCM
1 7/8"	3 1/2" x 9"	SCH 187M	

1970-81 CAMARO, 1964-77 CHEVELLE & MONTE CARLO, AND 1975-79 CHEVY II & NOVA,



- ★ CONVENTIONAL STYLE HEADERS FOR CARS WITH ENGINES IN STOCK LOCATION OR ENGINE SET BACK
- ★ WILL NOT CLEAR REAR ENGINE MOUNTS
- ★ WILL NOT FIT ANGLE PLUG HEADS
- ★ GASKETS & BOLTS INCLUDED

TUBE DIAMETER	COLLECTOR DIA./LENGTH	STANDARD CHEVY
1 1/2" - 1 5/8"	3" x 8"	SCH 164V
1 5/8"	3" x 8"	SCH 165
1 5/8" - 1 3/4"	3" x 8"	SCH 165V
1 5/8" - 1 3/4" - 1 7/8"	3 1/2" x 9"	SCH 165V3
1 3/4"	3 1/2" x 8"	SCH 166
1 3/4"	3" x 8"	SCH 166-3
1 3/4" - 1 7/8"	3 1/2" x 9"	SCH 166V
1 7/8"	3 1/2" x 9"	SCH 167

\*NOTE: IF YOU ARE UNSURE WHICH STYLE OF HEADER FITS YOUR PARTICULAR CAR, CONSULT THE SCHOENFELD HEADERS CATALOG OR VISIT [WWW.SCHOENFELDHEADERS.COM](http://WWW.SCHOENFELDHEADERS.COM) FOR A MORE DETAILED DESCRIPTION

Place your order at (479) 646-6988, Fax to (479) 646-5939, or visit [www.southwestspeed.com](http://www.southwestspeed.com)

# SCHOENFELD HEADERS - STREET STOCK

1970-81 CAMARO, 1972-77 MONTE CARLO, AND 1975-79 CHEVY II & NOVA

★ CONVENTIONAL STYLE HEADERS FOR CARS WITH ENGINES IN STOCK LOCATION OR ENGINE SET BACK

★ WILL NOT FIT CHEVELLE'S

★ WILL FIT STRAIGHT & ANGLE PLUG HEADS

★ WILL CLEAR SOLID SIDE & REAR ENGINE MOUNTS

★ WILL FIT STOCK CLUTCH LINKAGE

★ MUST USE SHORT OIL FILTER, SUCH AS #WFP 51069R (SEE PAGE 85)

★ GASKETS & BOLTS INCLUDED

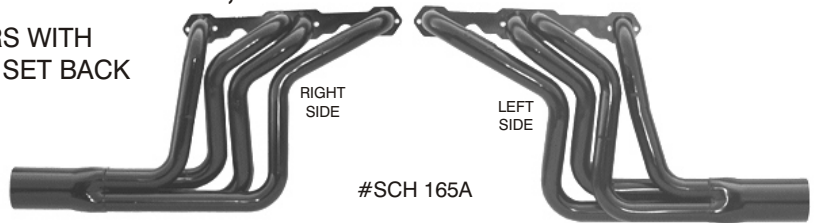

TUBE DIAMETER	COLLECTOR DIA./LENGTH	STANDARD CHEVY	CRATE MOTOR	SPREAD PORT	CHEVY 18°
1 1/2" - 1 5/8"	3" x 8"	SCH 164VA			
1 5/8"	3" x 8"	SCH 165A	SCH 165ACM		
1 5/8" - 1 3/4"	3" x 8"	SCH 165VA	SCH 165VACM		
1 5/8" - 1 3/4" - 1 7/8"	3 1/2" x 9"	SCH 165V3A	SCH 165V3ACM		
1 3/4"	3 1/2" x 8"	SCH 166A	SCH 166ACM	SCH 166ASP	SCH 166A18
1 3/4"	3" x 8"	SCH 166A-3	SCH 166ACM-3	SCH 166ASP-3	SCH 166A18-3
1 3/4" - 1 7/8"	3 1/2" x 9"	SCH 166VA	SCH 166VACM	SCH 166VASP	SCH 166VA18
1 7/8"	3 1/2" x 9"	SCH 167A		SCH 167ASP	SCH 167A18

## FOR LS1 MOTORS

1972-87 MONTE CARLO, 1978-87 MALIBU, PONTIAC GRAND PRIX, OLDS CUTLASS, & BUICK REGAL, AND 1970-81 CAMARO

★ CLEARS SOLID SIDE & REAR ENGINE MOUNTS

★ MOTOR MUST BE IN STOCK LOCATION

★ WILL FIT STRAIGHT & ANGLE PLUG HEADS

★ WILL NOT CLEAR STOCK MANUAL CLUTCH LINKAGE BALL

★ WILL NOT FIT WITH SOME MINI-STARTERS

★ WILL NOT FIT SOME KICK-OUT OIL PANS

★ WILL NOT CLEAR AIR-CONDITIONER BOX

★ MUST USE SHORT OIL FILTER

★ GASKETS & BOLTS INCLUDED

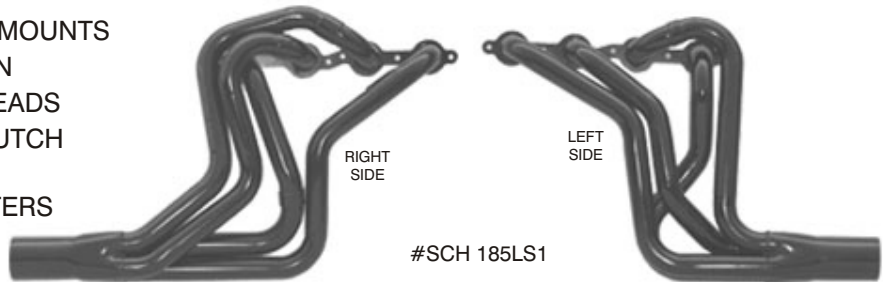

TUBE DIAMETER	COLLECTOR DIA./LENGTH	CHEVY LS1-LS7
1 5/8"	3" x 8"	SCH 185LS1
1 5/8" - 1 3/4"	3" x 8"	SCH 185VLS1
1 3/4"	3 1/2" x 8"	SCH 186LS1
1 3/4"	3" x 8"	SCH 186LS1-3

## FOR FORD MOTORS

DESIGNED TO FIT CAMARO, INTERMEDIATE GM, FRONT CLIPS ALSO FITS 1967-72 FORD TRUCKS

★ GASKETS & BOLTS INCLUDED

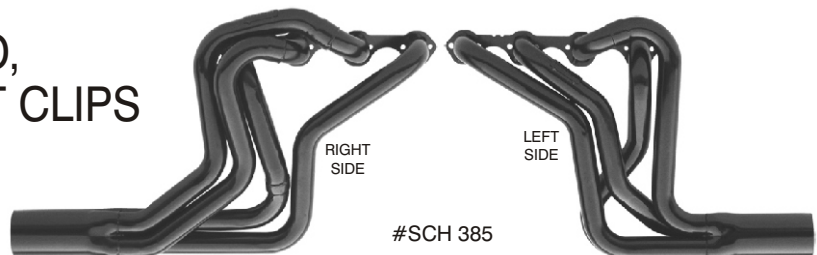

TUBE DIAMETER	COLLECTOR DIA./LENGTH	WINDSOR 289-302-351	DART/"N" HEAD	CRATE MOTOR
1 5/8"	3" x 8"	SCH 385	SCH 385N	SCH 385CM
1 5/8" - 1 3/4"	3" x 8"	SCH 385V	SCH 385VN	SCH 385VCM
1 3/4"	3 1/2" x 8"	SCH 386	SCH 386N	SCH 386CM

\*NOTE: IF YOU ARE UNSURE WHICH STYLE OF HEADER FITS YOUR PARTICULAR CAR, CONSULT THE SCHOENFELD HEADERS CATALOG OR VISIT [WWW.SCHOENFELDHEADERS.COM](http://WWW.SCHOENFELDHEADERS.COM) FOR A MORE DETAILED DESCRIPTION

Place your order at (479) 646-6988, Fax to (479) 646-5939, or visit [www.southwestspeed.com](http://www.southwestspeed.com)

# SCHOENFELD HEADERS - CHASSIS HEADERS FOR SMALL BLOCK CHEVY'S

- ★ FITS SMALL BLOCK CHEVY'S & NUMEROUS POPULAR CHASSIS
- ★ WILL FIT STRAIGHT & ANGLE PLUG HEADS
- ★ GASKETS & BOLTS INCLUDED

TUBE DIAMETER	COLLECTOR DIA./LENGTH	STANDARD CHEVY	CRATE MOTOR	SPREAD PORT
1 5/8"	3" x 8"	SCH 151	SCH 151CM	
1 5/8" - 1 3/4"	3 1/2" x 8"	SCH 151V	SCH 151VCM	
1 3/4"	3 1/2" x 8"	SCH 152	SCH 152CM	SCH 152SP
1 3/4"	3" x 8"	SCH 152-3	SCH 152CM-3	SCH 152SP-3
1 3/4" - 1 7/8"	3 1/2" x 9"	SCH 152V	SCH 152VCM	SCH 152VSP
1 7/8"	3 1/2" x 9"	SCH 153	SCH 153CM	SCH 153SP
1 7/8" - 2"	3 1/2" x 9"	SCH 153V	SCH 153VCM	SCH 153VSP



- ★ FITS SMALL BLOCK CHEVY'S & NUMEROUS POPULAR CHASSIS
- ★ WILL FIT STRAIGHT & ANGLE PLUG HEADS
- ★ GASKETS & BOLTS INCLUDED

TUBE DIAMETER	COLLECTOR DIA./LENGTH	STANDARD CHEVY	CRATE MOTOR	SPREAD PORT
1 5/8"	3" x 8"	SCH 151E	SCH 151ECM	
1 5/8"*	3" x 8"	SCH 151EL*	SCH 151ELCM*	
1 5/8" - 1 3/4"	3 1/2" x 8"	SCH 151EV	SCH 151EVC	
1 3/4"	3 1/2" x 8"	SCH 152E	SCH 152ECM	SCH 152ESP
1 3/4"	3" x 8"	SCH 152E-3	SCH 152ECM-3	SCH 152ESP-3
1 3/4" - 1 7/8"	3 1/2" x 9"	SCH 152EV	SCH 152EVC	SCH 152EVSP
1 7/8"	3 1/2" x 9"	SCH 153E		SCH 153ESP
1 7/8" - 2"	3 1/2" x 9"	SCH 153EV		SCH 153EVSP

\*"EL" HEADERS HAVE 30" PRIMARIES



## FOR SMALL BLOCK CHEVY LS1-LS7

- ★ FITS CHEVY LS1 - LS7 & NUMEROUS POPULAR CHASSIS
- ★ WILL FIT STRAIGHT & ANGLE PLUG HEADS
- ★ GASKETS & BOLTS INCLUDED

TUBE DIAMETER	COLLECTOR DIA./LENGTH	CHEVY LS1-LS7
1 5/8"	3" x 8"	SCH 151LS1
1 5/8" - 1 3/4"	3 1/2" x 8"	SCH 151VLS1
1 3/4"	3 1/2" x 8"	SCH 152LS1
1 3/4"	3" x 8"	SCH 152LS1-3
1 3/4" - 1 7/8"	3 1/2" x 9"	SCH 152VLS1



## FOR FORD'S

- ★ FITS FORD'S & NUMEROUS POPULAR CHASSIS
- ★ GASKETS & BOLTS INCLUDED

TUBE DIAMETER	COLLECTOR DIA./LENGTH	WINDSOR 289-302-351	DART/"N" HEAD
1 5/8"	3" x 8"	SCH 351	SCH 351N
1 5/8" - 1 3/4"	3 1/2" x 8"	SCH 351V	SCH 351VN
1 3/4"	3 1/2" x 8"	SCH 352	SCH 352N
1 3/4" - 1 7/8"	3 1/2" x 9"	SCH 352V	SCH 352VN



\*NOTE: IF YOU ARE UNSURE WHICH STYLE OF HEADER FITS YOUR PARTICULAR CAR, CONSULT THE SCHOENFELD HEADERS CATALOG OR VISIT [WWW.SCHOENFELDHEADERS.COM](http://WWW.SCHOENFELDHEADERS.COM) FOR A MORE DETAILED DESCRIPTION

Place your order at (479) 646-6988, Fax to (479) 646-5939, or visit [www.southwestspeed.com](http://www.southwestspeed.com)



# SCHOENFELD HEADERS - CROSSOVER

## FOR SMALL BLOCK CHEVY'S

★ CONVENTIONAL CROSSOVER HEADERS TO FIT SMALL BLOCK CHEVY'S & NUMEROUS POPULAR CHASSIS

★ WILL NOT FIT JERICO TRANSMISSION; GASKETS & BOLTS INCLUDED

TUBE DIAMETER	COLLECTOR DIA./LENGTH	STANDARD CHEVY	CRATE MOTOR	SPREAD PORT	CHEVY 18°
1 1/2" - 1 5/8"	3" x 8"	SCH 134V			
1 5/8"	3" x 8"	SCH 135	SCH 135CM		
1 5/8" - 1 3/4"	3 1/2" x 8"	SCH 135V	SCH 135VCM		
1 5/8" - 1 3/4"	3" x 8"	SCH 135V-3	SCH 135VCM-3		
1 3/4"	3 1/2" x 8"	SCH 136	SCH 136CM	SCH 136SP	SCH 136-18
1 3/4" - 1 7/8"	3 1/2" x 9"	SCH 136V	SCH 136VCM	SCH 136VSP	SCH 136V18
1 3/4" - 2"	3 1/2" x 9"	SCH 136V2		SCH 136V2SP	SCH 136V2-18
1 3/4" - 1 7/8" - 2"	3 1/2" x 9"	SCH 136V3		SCH 136V3SP	SCH 136V3-18



★ CONVENTIONAL CROSSOVER HEADERS TO FIT SMALL BLOCK CHEVY'S & NUMEROUS POPULAR CHASSIS

★ WILL NOT FIT JERICO TRANSMISSION

★ GASKETS & BOLTS INCLUDED

TUBE DIAMETER	COLLECTOR DIA./LENGTH	STANDARD CHEVY	CRATE MOTOR	SPREAD PORT
1 1/2" - 1 5/8"	3" x 8"	SCH 134VH		
1 5/8"	3" x 8"	SCH 135H	SCH 135HCM	
1 5/8" - 1 3/4"	3 1/2" x 8"	SCH 135VH	SCH 135VHCM	
1 5/8" - 1 3/4"	3" x 8"	SCH 135VH-3	SCH 135VHCM-3	
1 3/4"	3 1/2" x 8"	SCH 136H	SCH 136HCM	SCH 136HSP
1 3/4" - 1 7/8"	3 1/2" x 9"	SCH 136VH	SCH 136VHCM	SCH 136VHSP
1 3/4" - 2"	3 1/2" x 9"	SCH 136V2H		SCH 136V2HSP
1 3/4" - 1 7/8" - 2"	3 1/2" x 9"	SCH 136V3H		SCH 136V3HSP



★ CONVENTIONAL CROSSOVER HEADERS TO FIT SMALL BLOCK CHEVY'S & NUMEROUS POPULAR CHASSIS

★ WILL NOT FIT JERICO TRANSMISSION

★ GASKETS & BOLTS INCLUDED

TUBE DIAMETER	COLLECTOR DIA./LENGTH	STANDARD CHEVY	CRATE MOTOR	SPREAD PORT	CHEVY 18°
1 1/2" - 1 5/8"	3" x 8"	SCH 144V			
1 5/8"	3" x 8"	SCH 145	SCH 145CM		
1 5/8" - 1 3/4"	3 1/2" x 9"	SCH 145V	SCH 145VCM		
1 5/8" - 1 3/4"	3" x 9"	SCH 145V-3	SCH 145VCM-3		
1 3/4"	3 1/2" x 9"	SCH 146	SCH 146CM	SCH 146SP	SCH 146-18
1 3/4" - 1 7/8"	3 1/2" x 9"	SCH 146V	SCH 146VCM	SCH 146VSP	SCH 146V18
1 3/4" - 2"	3 1/2" x 9"	SCH 146V2		SCH 146V2SP	SCH 146V2-18
1 3/4" - 1 7/8" - 2"	3 1/2" x 9"	SCH 146V3		SCH 146V3SP	SCH 146V3-18



## TRI-Y CROSSOVER HEADERS

★ TRI-Y CONVENTIONAL CROSSOVER HEADERS TO FIT SMALL BLOCK CHEVY'S & NUMEROUS POPULAR CHASSIS

★ 4 INTO 2 INTO 1 CONFIGURATION FOR INCREASED TORQUE

★ WILL NOT FIT JERICO TRANSMISSION

★ GASKETS & BOLTS INCLUDED

TUBE DIAMETER	COLLECTOR DIAMETER	STANDARD CHEVY	CRATE MOTOR	CHEVY 18°
1 5/8" - 1 3/4"	3"	SCH 135VY	SCH 135VYCM	SCH 135VY18
1 3/4" - 1 7/8" - 2"	3 1/2"	SCH 136V3Y	SCH 136V3YCM	SCH 136V3Y18

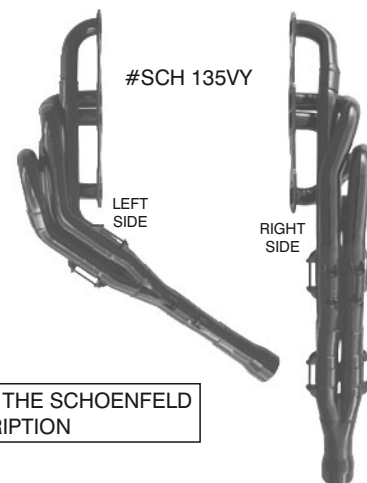

\*NOTE: IF YOU ARE UNSURE WHICH STYLE OF HEADER FITS YOUR PARTICULAR CAR, CONSULT THE SCHOENFELD HEADERS CATALOG OR VISIT [WWW.SCHOENFELDHEADERS.COM](http://WWW.SCHOENFELDHEADERS.COM) FOR A MORE DETAILED DESCRIPTION

Place your order at (479) 646-6988, Fax to (479) 646-5939, or visit [www.southwestspeed.com](http://www.southwestspeed.com)

# SCHOENFELD HEADERS - CROSSOVER

## FOR SMALL BLOCK CHEVY LS1-LS7

- ★ CONVENTIONAL CROSSOVER HEADERS TO FIT CHEVY LS1-LS7 & NUMEROUS POPULAR CHASSIS

★ GASKETS & BOLTS INCLUDED

TUBE DIAMETER	COLLECTOR DIA./LENGTH	CHEVY LS1-LS7
1 5/8"	3" x 8"	SCH 135LS1
1 5/8" - 1 3/4"	3 1/2" x 8"	SCH 135VLS1
1 5/8" - 1 3/4"	3" x 8"	SCH 135VLS1-3
1 3/4"	3 1/2" x 8"	SCH 136LS1
1 3/4" - 1 7/8"	3 1/2" x 9"	SCH 136VLS1

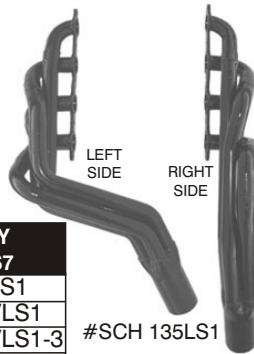

## FOR CHEVY 6 CYLINDER

- ★ CONVENTIONAL CROSSOVER HEADERS TO FIT CHEVY INLINE 6'S & NUMEROUS POPULAR CHASSIS

★ GASKETS & BOLTS INCLUDED

TUBE DIAMETER	COLLECTOR DIA./LENGTH	CHEVY 6 CYL.
1 5/8" - 1 3/4"	3" x 8"	SCH 845V
1 3/4"	3" x 8"	SCH 846



## FOR FORD'S

- ★ CONVENTIONAL CROSSOVER HEADERS TO FIT FORD'S & NUMEROUS POPULAR CHASSIS

★ GASKETS & BOLTS INCLUDED

TUBE DIAMETER	COLLECTOR DIA./LENGTH	WINDSOR 289-302-351	DART/"N" HEAD	CRATE MOTOR
1 5/8"	3" x 8"	SCH 335	SCH 335N	SCH 335CM
1 5/8" - 1 3/4"	3 1/2" x 8"	SCH 335V	SCH 335VN	SCH 335VCM
1 5/8" - 1 3/4"	3" x 8"	SCH 335V-3	SCH 335VN-3	SCH 335VCM-3
1 3/4"	3 1/2" x 9"	SCH 336	SCH 336N	SCH 336CM
1 3/4" - 1 7/8"	3 1/2" x 9"	SCH 336V	SCH 336VN	SCH 336VCM



## FOR MOPAR'S

- ★ CONVENTIONAL CROSSOVER HEADERS TO FIT MOPAR'S & NUMEROUS POPULAR CHASSIS

★ 3 STYLES AVAILABLE

★ GASKETS & BOLTS INCLUDED

TUBE DIAMETER	COLLECTOR DIA./LENGTH	STANDARD MOPAR	W-2*
1 5/8"	3" x 8"	SCH 445	SCH 445W2
1 5/8" - 1 3/4"	3 1/2" x 8"	SCH 445V	SCH 445VW2
1 5/8" - 1 3/4"	3" x 8"	SCH 445V-3	SCH 445VW2-3
1 3/4"	3 1/2" x 8"	SCH 446	SCH 446W2
1 3/4" - 1 7/8"	3 1/2" x 9"	SCH 446V	SCH 446VW2

TUBE DIAMETER	COLLECTOR DIA./LENGTH	STANDARD MOPAR	W-2*
1 5/8"	3" x 8"	SCH 435	SCH 435W2
1 5/8" - 1 3/4"	3 1/2" x 8"	SCH 435V	SCH 435VW2
1 5/8" - 1 3/4"	3" x 8"	SCH 435V-3	SCH 435VW2-3
1 3/4"	3 1/2" x 8"	SCH 436	SCH 436W2
1 3/4" - 1 7/8"	3 1/2" x 9"	SCH 436V	SCH 436VW2

TUBE DIAMETER	COLLECTOR DIA./LENGTH	STANDARD MOPAR	W-2*
1 5/8"	3" x 8"	SCH 435H	SCH 435HW2
1 5/8" - 1 3/4"	3 1/2" x 8"	SCH 435VH	SCH 435VHW2
1 5/8" - 1 3/4"	3" x 8"	SCH 435VH-3	SCH 435VHW2-3
1 3/4"	3 1/2" x 8"	SCH 436H	SCH 436HW2
1 3/4" - 1 7/8"	3 1/2" x 9"	SCH 436VH	SCH 436VHW2

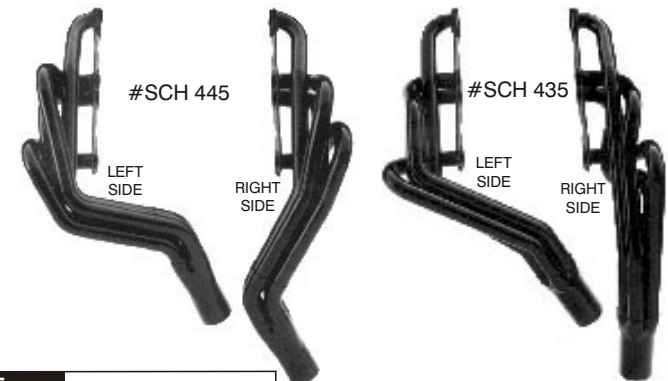

## FOR FORD'S - TRI-Y CROSSOVER HEADERS

- ★ TRI-Y CONVENTIONAL CROSSOVER HEADERS TO FIT FORD'S & NUMEROUS POPULAR CHASSIS

★ 4 INTO 2 INTO 1 CONFIGURATION FOR INCREASED TORQUE

★ GASKETS & BOLTS INCLUDED

TUBE DIAMETER	COLLECTOR DIAMETER	WINDSOR 289-302-351	DART/"N" HEAD	EDELBRÖCK/MCGUNEGILL
1 5/8" - 1 3/4"	3"	SCH 335VY	SCH 335VYN	SCH 335VYE
1 3/4" - 1 7/8" - 2"	3 1/2"	SCH 336V3Y	SCH 336V3YN	SCH 336V3YE

#SCH 335VY

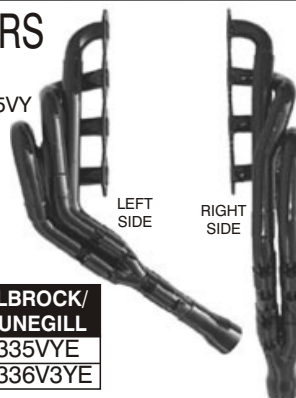

#SCH 435H



\*IF YOU ARE UNSURE WHICH STYLE OF HEADER FITS YOUR PARTICULAR CAR, CONSULT THE SCHOENFELD HEADERS CATALOG OR VISIT [WWW.SCHOENFELDHEADERS.COM](http://WWW.SCHOENFELDHEADERS.COM) FOR A MORE DETAILED DESCRIPTION

Place your order at (479) 646-6988, Fax to (479) 646-5939, or visit [www.southwestspeed.com](http://www.southwestspeed.com)

# SCHOENFELD HEADERS - 180° CROSSOVER

- ★180° CROSSOVER HEADERS TO FIT SMALL BLOCK CHEVY'S & NUMEROUS POPULAR CHASSIS
- ★EXITS THROUGH LOWER RIGHT-SIDE DOOR
- ★USES 48" EXTENSION TUBES
- ★GASKETS & BOLTS INCLUDED

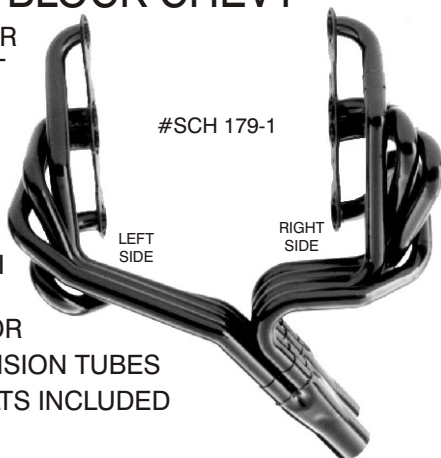

TUBE DIAMETER	COLLECTOR DIA./LENGTH	STANDARD CHEVY	SPREAD PORT
1 5/8"	3" x 8"	SCH 179-1	
1 5/8" - 1 3/4"	3 1/2" x 9"	SCH 179V-1	
1 3/4"	3 1/2" x 9"	SCH 180-1	SCH 180-1SP

- ★180° CROSSOVER HEADERS TO FIT SMALL BLOCK CHEVY'S & NUMEROUS POPULAR CHASSIS
- ★EXITS THROUGH FENDER BEHIND RIGHT-FRONT TIRE
- ★USES 36" EXTENSION TUBES
- ★GASKETS & BOLTS INCLUDED

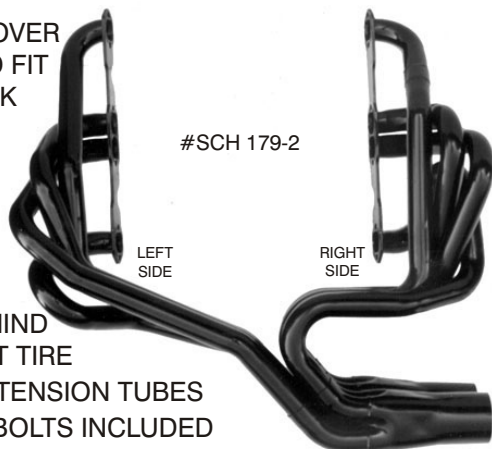

TUBE DIAMETER	COLLECTOR DIA./LENGTH	STANDARD CHEVY	SPREAD PORT
1 5/8"	3" x 8"	SCH 179-2	
1 5/8" - 1 3/4"	3 1/2" x 9"	SCH 179V-2	
1 3/4"	3 1/2" x 9"	SCH 180-2	SCH 180-2SP

## FOR FORD'S

- ★180° CROSSOVER HEADERS TO FIT FORD'S & NUMEROUS POPULAR CHASSIS, INCLUDING MANY OF THE PAVEMENT CHASSIS USED TODAY
- ★PLEASE SPECIFY IF THE HEADERS ARE FOR A 351 BLOCK, AS IT USES DIFFERENT COLLECTORS
- ★GASKETS & BOLTS INCLUDED

TUBE DIAMETER	COLLECTOR DIA./LENGTH	WINDSOR 289-302	WINDSOR 351	DART/"N" HEAD
1 5/8"	3" x 8"	SCH 380-1	SCH 380-1-351	SCH 380-1N
1 5/8" - 1 3/4"	3 1/2" x 9"	SCH 380V-1	SCH 380V-1-351	SCH 380V-1N

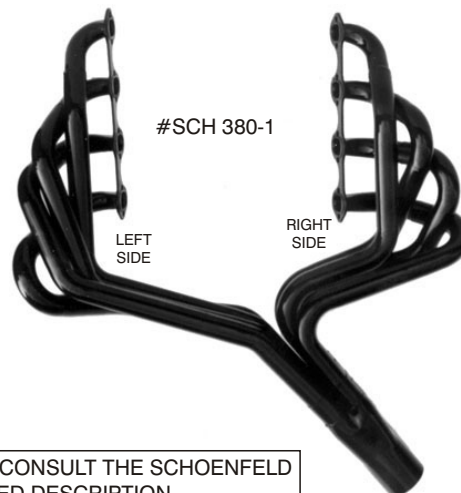

## FOR SMALL BLOCK CHEVY

- ★180° CROSSOVER HEADERS TO FIT SMALL BLOCK CHEVY'S & NUMEROUS POPULAR CHASSIS, INCLUDING MANY OF THE PAVEMENT CHASSIS USED TODAY
- ★GASKETS & BOLTS INCLUDED

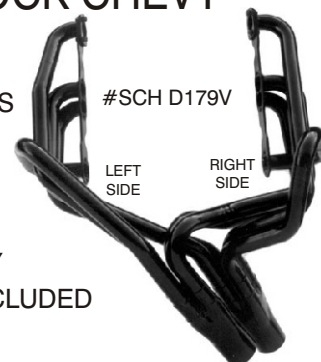

TUBE DIAMETER	COLLECTOR DIA./LENGTH	STANDARD CHEVY	SPREAD PORT
1 1/2" - 1 3/4"	3 1/2" x 9"	SCH D178V2	
1 5/8" - 1 3/4"	3 1/2" x 9"	SCH D179V	
1 5/8" - 1 7/8"	3 1/2" x 9"	SCH D179V2	
1 3/4"	3 1/2" x 9"	SCH D180	SCH D180SP
1 3/4" - 1 7/8"	3 1/2" x 9"	SCH D180V	SCH D180VSP
1 3/4" - 1 7/8" - 2"	3 1/2" x 9"	SCH D180V3	SCH D180V3SP
1 7/8"	3 1/2" x 9"	SCH D181	SCH D181SP

- ★180° CROSSOVER HEADERS TO FIT SMALL BLOCK CHEVY'S & NUMEROUS POPULAR CHASSIS, INCLUDING MANY OF THE PAVEMENT CHASSIS USED TODAY
- ★GASKETS & BOLTS INCLUDED

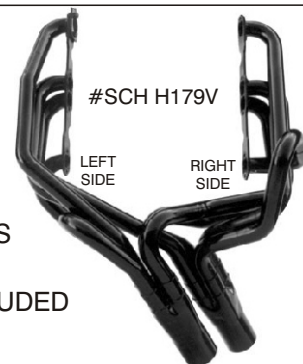

TUBE DIAMETER	COLLECTOR DIA./LENGTH	STANDARD CHEVY	SPREAD PORT
1 1/2" - 1 3/4"	3 1/2" x 9"	SCH H178V2	
1 5/8" - 1 3/4"	3 1/2" x 9"	SCH H179V	
1 5/8" - 1 7/8"	3 1/2" x 9"	SCH H179V2	
1 3/4"	3 1/2" x 9"	SCH H180	SCH H180SP
1 3/4" - 1 7/8"	3 1/2" x 9"	SCH H180V	SCH H180VSP
1 3/4" - 1 7/8" - 2"	3 1/2" x 9"	SCH H180V3	SCH H180V3SP
1 7/8"	3 1/2" x 9"	SCH H181	SCH H181SP

\*NOTE: IF YOU ARE UNSURE WHICH STYLE OF HEADER FITS YOUR PARTICULAR CAR, CONSULT THE SCHOENFELD HEADERS CATALOG OR VISIT [WWW.SCHOENFELDHEADERS.COM](http://WWW.SCHOENFELDHEADERS.COM) FOR A MORE DETAILED DESCRIPTION

Place your order at (479) 646-6988, Fax to (479) 646-5939, or visit [www.southwestspeed.com](http://www.southwestspeed.com)



# SCHOENFELD HEADERS - DIRT LATE MODEL FOR SMALL BLOCK CHEVY'S

- ★ FITS SMALL BLOCK CHEVY'S & NUMEROUS POPULAR DIRT LATE MODEL CHASSIS
- ★ BOTH SIDES GO OVER THE FRAME
- ★ LONGER PRIMARIES FOR MAXIMUM TORQUE & HORSEPOWER; GASKETS & BOLTS INCLUDED

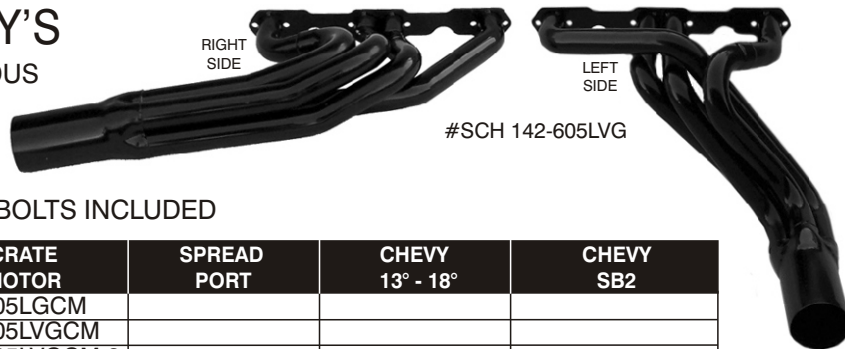

TUBE DIAMETER	COLLECTOR DIA./LENGTH	STANDARD CHEVY	CRATE MOTOR	SPREAD PORT	CHEVY 13° - 18°	CHEVY SB2
1 5/8"	3" x 8"	141-605LG	141-605LGCM			
1 5/8" - 1 3/4"	3 1/2" x 8"	141-605LVG	141-605LVGCM			
1 5/8" - 1 3/4"	3" x 8"	141-605LVG-3	141-605LVGCM-3			
1 3/4"	3 1/2" x 8"	142-605LG	142-605LGCM	142-605LGSP	142-605LG18	142-605LGSB2
1 3/4"	3" x 8"	142-605LG-3	142-605LGCM-3	142-605LGSP-3	142-605LG18-3	142-605LGSB2-3
1 3/4" - 1 7/8"	3 1/2" x 9"	142-605LVG	142-605LVGCM	142-605LVGSP	142-605LVG18	142-605LVGSB2
1 3/4" - 1 7/8"	3" x 8"	142-605LVG-3	142-605LVGCM-3	142-605LVGSP-3	142-605LVG18-3	142-605LVGSB2-3
1 3/4 - 1 7/8 - 2"	3 1/2" x 9"	142-605LV3G	142-605LV3GCM	142-605LV3GSP	142-605LV3G18	142-605LV3GSB2
1 7/8"	3 1/2" x 9"	143-605LG		143-605LGSP	143-605LG18	143-605LGSB2
1 7/8" - 2"	3 1/2" x 9"	143-605LVG		143-605LVGSP	143-605LVG18	143-605LVGSB2

NOTE: ADD "SCH" TO THE FRONT OF ALL PART NUMBERS

- ★ FITS SMALL BLOCK CHEVY'S & NUMEROUS POPULAR DIRT LATE MODEL CHASSIS
- ★ BOTH SIDES GO OVER THE FRAME
- ★ LONGER PRIMARIES FOR MAXIMUM TORQUE & HORSEPOWER
- ★ GASKETS & BOLTS INCLUDED



TUBE DIAMETER	COLLECTOR DIA./LENGTH	STANDARD CHEVY	CRATE MOTOR	SPREAD PORT	CHEVY 13° - 18°	CHEVY SB2
1 5/8"	3" x 8"	141-525L	141-525LCM			
1 5/8" - 1 3/4"	3 1/2" x 8"	141-525LV	141-525LVCM	141-525LVSP		
1 5/8" - 1 3/4"	3" x 8"	141-525LV-3	141-525LVCM-3	141-525LVSP-3		
1 3/4"	3 1/2" x 8"	142-525L	142-525LCM	142-525LSP	142-525L18	142-525LSB2
1 3/4"	3" x 8"	142-525L-3	142-525LCM-3	142-525LSP-3	142-525L18-3	142-525LSB2-3
1 3/4" - 1 7/8"	3 1/2" x 9"	142-525LV	142-525LVCM	142-525LVSP	142-525LV18	142-525LVSB2
1 3/4" - 1 7/8"	3" x 8"	142-525LV-3	142-525LVCM-3	142-525LVSP-3	142-525LV18-3	142-525LVSB2-3
1 3/4 - 1 7/8 - 2"	3 1/2" x 9"	142-525LV3	142-525LV3CM	142-525LV3SP	142-525LV3-18	142-525LV3SB2
1 7/8"	3 1/2" x 9"	143-525L		143-525LSP	143-525L18	143-525LSB2
1 7/8" - 2"	3 1/2" x 9"	143-525LV		143-525LVSP	143-525LV18	143-525LVSB2

NOTE: ADD "SCH" TO THE FRONT OF ALL PART NUMBERS

- ★ FITS SMALL BLOCK CHEVY'S
- ★ DESIGNED TO FIT NUMEROUS POPULAR DIRT LATE MODEL CHASSIS
- ★ GASKETS & BOLTS INCLUDED



TUBE DIAMETER	COLLECTOR DIA./LENGTH	STANDARD CHEVY	CRATE MOTOR	SPREAD PORT	CHEVY 13° - 18°	CHEVY SB2
1 5/8"	3" x 8"	141-505LG	141-505LGCM			
1 5/8" - 1 3/4"	3 1/2" x 8"	141-505LVG	141-505LVGCM			
1 5/8" - 1 3/4"	3" x 8"	141-505LVG-3	141-505LVGCM-3			
1 3/4"	3 1/2" x 8"	142-505LG	142-505LGCM	142-505LGSP	142-505LG18	142-505LGSB2
1 3/4"	3" x 8"	142-505LG-3	142-505LGCM-3	142-505LGSP-3	142-505LG18-3	142-505LGSB2-3
1 3/4" - 1 7/8"	3 1/2" x 9"	142-505LVG	142-505LVGCM	142-505LVGSP	142-505LVG18	142-505LVGSB2
1 3/4" - 1 7/8"	3" x 8"	142-505LVG-3	142-505LVGCM-3	142-505LVGSP-3	142-505LVG18-3	142-505LVGSB2-3
1 3/4 - 1 7/8 - 2"	3 1/2" x 9"	142-505LV3G	142-505LV3GCM	142-505LV3GSP	142-505LV3G18	142-505LV3GSB2
1 7/8"	3 1/2" x 9"	143-505LG		143-505LGSP	143-505LG18	143-505LGSB2
1 7/8" - 2"	3 1/2" x 9"	143-505LVG		143-505LVGSP	143-505LVG18	143-505LVGSB2

NOTE: ADD "SCH" TO THE FRONT OF ALL PART NUMBERS

\*NOTE: IF YOU ARE UNSURE WHICH STYLE OF HEADER FITS YOUR PARTICULAR CAR, CONSULT THE SCHOENFELD HEADERS CATALOG OR VISIT [WWW.SCHOENFELDHEADERS.COM](http://WWW.SCHOENFELDHEADERS.COM) FOR A MORE DETAILED DESCRIPTION

Place your order at (479) 646-6988, Fax to (479) 646-5939, or visit [www.southwestspeed.com](http://www.southwestspeed.com)

# SCHOENFELD HEADERS - DIRT LATE MODEL FOR SMALL BLOCK CHEVY'S - TRI-Y HEADERS

- ★ FITS SMALL BLOCK CHEVY'S & ALMOST ALL POPULAR DIRT LATE MODEL CHASSIS
- ★ 4 INTO 2 INTO 1 CONFIGURATION FOR INCREASED TORQUE
- ★ LONGER PRIMARIES FOR MAXIMUM TORQUE & HORSEPOWER
- ★ GASKETS & BOLTS INCLUDED



TUBE DIAMETER	COLLECTOR DIAMETER	STANDARD CHEVY	CRATE MOTOR	SPREAD PORT	CHEVY 13° - 18°	CHEVY SB2
1 5/8" - 1 3/4"	3"	141-60LVY	141-60LVYCM			
1 5/8" - 1 3/4" - 1 7/8"	3 1/2"	141-60LV3Y	141-60LV3YCM			
1 3/4" - 1 7/8"	3 1/2"	142-60LVY	142-60LVYCM	142-60LVYSP	142-60LVY18	142-60LVYSB2
1 3/4" - 1 7/8" - 2"	3 1/2"	142-60LV3Y	142-60LV3YCM	142-60LV3YSP	142-60LV3Y18	142-60LV3YSB2
1 7/8" - 2"	3 1/2"	143-60LVY		143-60LVYSP	143-60LVY18	143-60LVYSB2

NOTE: ADD "SCH" TO THE FRONT OF ALL PART NUMBERS

## FOR SMALL BLOCK CHEVY LS1 - LS7

- ★ FITS SMALL BLOCK CHEVY LS1-LS7 & MOST POPULAR DIRT LATE MODEL CHASSIS
- ★ BOTH SIDES GO OVER THE FRAME; LONGER PRIMARIES FOR MAXIMUM TORQUE & HORSEPOWER
- ★ GASKETS & BOLTS INCLUDED

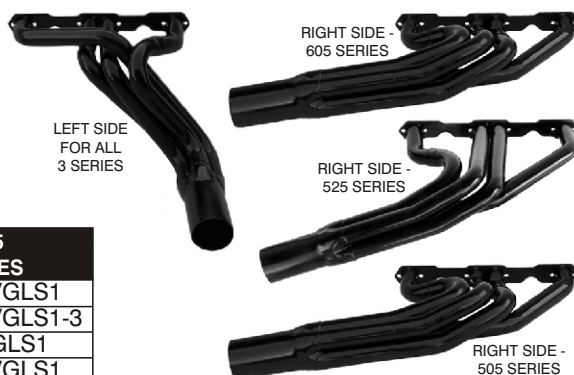

TUBE DIAMETER	COLLECTOR DIA./LENGTH	605 SERIES	525 SERIES	505 SERIES
1 5/8" - 1 3/4"	3 1/2" x 8"	141-605LVGLS1	141-525LVLS1	141-505LVGLS1
1 5/8" - 1 3/4"	3" x 8"	141-605LVGLS1-3	141-525LVLS1-3	141-505LVGLS1-3
1 3/4"	3 1/2" x 8"	142-605LGLS1	142-525LLS1	142-505LGLS1
1 3/4" - 1 7/8"	3 1/2" x 9"	142-605LVGLS1	142-525LVLS1	142-505LVGLS1

NOTE: ADD "SCH" TO THE FRONT OF ALL PART NUMBERS

## FOR FORD'S

- ★ FITS FORD 289-302-351 WINDSOR'S & MOST POPULAR DIRT LATE MODEL CHASSIS
- ★ GASKETS & BOLTS INCLUDED

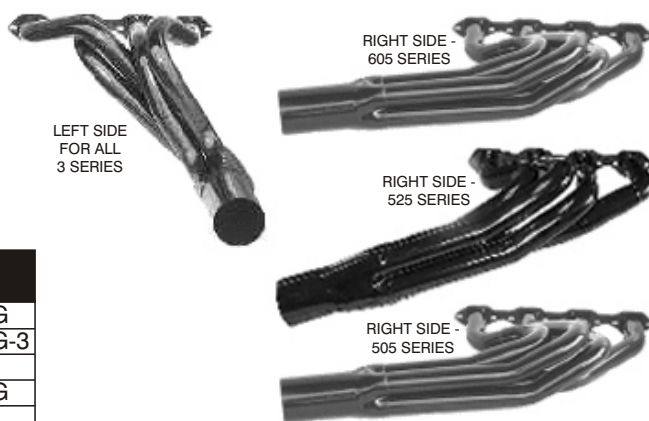

TUBE DIAMETER	COLLECTOR DIA./LENGTH	605 SERIES	525 SERIES	505 SERIES
1 5/8" - 1 3/4"	3 1/2" x 8"	341-605LVG	341-525LV	341-505LVG
1 5/8" - 1 3/4"	3" x 8"	341-605LVG-3	341-525LV-3	341-505LVG-3
1 3/4"	3 1/2" x 8"	342-605LG	342-525L	342-505LG
1 3/4" - 1 7/8"	3 1/2" x 9"	342-605LVG	342-525LV	342-505LVG

NOTE: ADD "SCH" TO THE FRONT OF ALL PART NUMBERS

## FOR FORD ALUMINUM SVO

- ★ FITS FORD SVO, BOTH SQUARE PORT & ROUND PORT
- ★ FITS MOST POPULAR DIRT LATE MODEL CHASSIS

TUBE DIAMETER	COLLECTOR DIA./LENGTH	ALUM. SVO SQUARE PORT	ALUM. SVO ROUND PORT
1 3/4" - 1 7/8"	3 1/2" x 9"	SCH 642LV	SCH 642LVRP
1 7/8"	3 1/2" x 9"	SCH 643L	SCH 643LRP

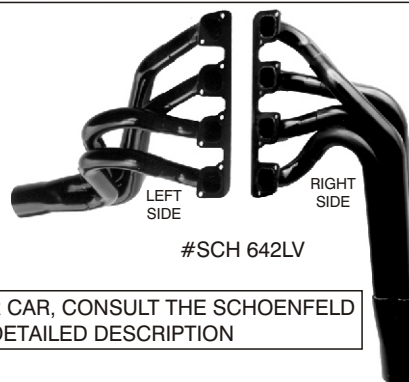

\*NOTE: IF YOU ARE UNSURE WHICH STYLE OF HEADER FITS YOUR PARTICULAR CAR, CONSULT THE SCHOENFELD HEADERS CATALOG OR VISIT [WWW.SCHOENFELDHEADERS.COM](http://WWW.SCHOENFELDHEADERS.COM) FOR A MORE DETAILED DESCRIPTION

Place your order at (479) 646-6988, Fax to (479) 646-5939, or visit [www.southwestspeed.com](http://www.southwestspeed.com)

# SCHOENFELD HEADERS - DIRT LATE MODEL FOR MOPAR'S

- ★ FITS MOST POPULAR DIRT LATE MODEL CHASSIS
- ★ BOTH SIDES GO OVER THE FRAME
- ★ LONGER PRIMARIES FOR MAXIMUM TORQUE & HORSEPOWER

TUBE DIAMETER	COLLECTOR DIA./LENGTH	STANDARD MOPAR	W-2*	W-9
1 5/8"	3" x 8"	441-605LG	441-605LGW2	
1 5/8" - 1 3/4"	3 1/2" x 8"	441-605LVG	441-605LVGW2	
1 5/8" - 1 3/4"	3" x 8"	441-605LVG-3	441-605LVGW2-3	
1 3/4"	3 1/2" x 8"	442-605LG	442-605LGW2	442-605LGW9
1 3/4" - 1 7/8"	3 1/2" x 9"	442-605LVG	442-605LVGW2	442-605LVGW9
1 3/4" - 1 7/8" - 2"	3 1/2" x 9"			442-605LV3GW9
1 7/8"	3 1/2" x 9"			443-605LGW9
1 7/8" - 2"	3 1/2" x 9"			443-605LVGW9

\*FOR W-2 FLANGES, SPECIFY 4" OR 4 3/4" SPREAD ON CENTER BOLTS  
NOTE: ADD "SCH" TO THE FRONT OF ALL PART NUMBERS



TUBE DIAMETER	COLLECTOR DIA./LENGTH	STANDARD MOPAR	W-2*	W-9
1 5/8"	3" x 8"	441-525LG	441-525LGW2	
1 5/8" - 1 3/4"	3 1/2" x 8"	441-525LVG	441-525LVGW2	
1 5/8" - 1 3/4"	3" x 8"	441-525LVG-3	441-525LVGW2-3	
1 3/4"	3 1/2" x 8"	442-525LG	442-525LGW2	442-525LGW9
1 3/4" - 1 7/8"	3 1/2" x 9"	442-525LVG	442-525LVGW2	442-525LVGW9
1 3/4" - 1 7/8" - 2"	3 1/2" x 9"			442-525LV3GW9
1 7/8"	3 1/2" x 9"			443-525LGW9
1 7/8" - 2"	3 1/2" x 9"			443-525LVGW9

\*FOR W-2 FLANGES, SPECIFY 4" OR 4 3/4" SPREAD ON CENTER BOLTS  
NOTE: ADD "SCH" TO THE FRONT OF ALL PART NUMBERS



TUBE DIAMETER	COLLECTOR DIA./LENGTH	STANDARD MOPAR	W-2*	W-9
1 5/8"	3" x 8"	441-505LG	441-505LGW2	
1 5/8" - 1 3/4"	3 1/2" x 8"	441-505LVG	441-505LVGW2	
1 5/8" - 1 3/4"	3" x 8"	441-505LVG-3	441-505LVGW2-3	
1 3/4"	3 1/2" x 8"	442-505LG	442-505LGW2	442-505LGW9
1 3/4" - 1 7/8"	3 1/2" x 9"	442-505LVG	442-505LVGW2	442-505LVGW9
1 3/4" - 1 7/8" - 2"	3 1/2" x 9"			442-505LV3GW9
1 7/8"	3 1/2" x 9"			443-505LGW9
1 7/8" - 2"	3 1/2" x 9"			443-505LVGW9

\*FOR W-2 FLANGES, SPECIFY 4" OR 4 3/4" SPREAD ON CENTER BOLTS  
NOTE: ADD "SCH" TO THE FRONT OF ALL PART NUMBERS



## FOR MOPAR'S - TRI-Y HEADERS

TUBE DIAMETER	COLLECTOR DIAMETER	STANDARD MOPAR	W-2*	W-9
1 5/8" - 1 3/4"	3"	441-60VY	441-60VYW2	
1 5/8" - 1 3/4"	3"	441-60VY	441-60VYW2	
1 5/8" - 1 3/4" - 1 7/8"	3 1/2"	441-60V3Y	441-60V3YW2	
1 3/4" - 1 7/8"	3 1/2"	442-60VY	442-60VYW2	442-60VYW9
1 3/4" - 1 7/8" - 2"	3 1/2"			442-60V3YW9
1 7/8" - 2"	3 1/2"			443-60VYW9

\*FOR W-2 FLANGES, SPECIFY 4" OR 4 3/4" SPREAD ON CENTER BOLTS  
NOTE: ADD "SCH" TO THE FRONT OF ALL PART NUMBERS

- ★ 4 INTO 2 INTO 1 CONFIGURATION FOR INCREASED TORQUE
- ★ FITS MOST POPULAR DIRT LATE MODEL CHASSIS
- ★ LONGER PRIMARIES FOR MAXIMUM TORQUE & HORSEPOWER

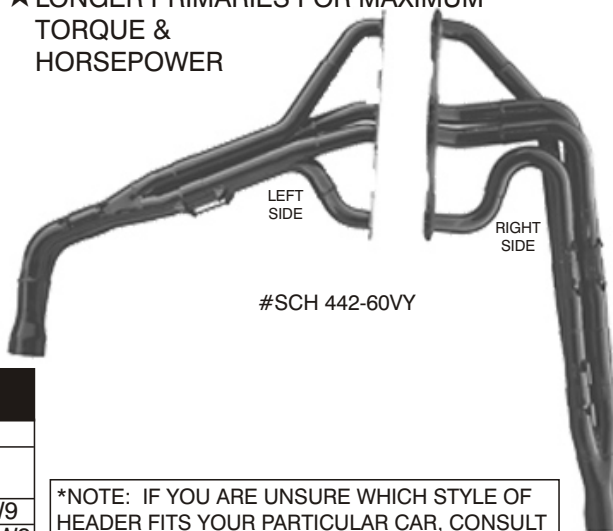

TUBE DIAMETER	COLLECTOR DIAMETER	STANDARD MOPAR	W-2*	W-9
1 5/8" - 1 3/4"	3"	441-50VY	441-50VYW2	
1 5/8" - 1 3/4"	3"	441-50VY	441-50VYW2	
1 5/8" - 1 3/4" - 1 7/8"	3 1/2"	441-50V3Y	441-50V3YW2	
1 3/4" - 1 7/8"	3 1/2"	442-50VY	442-50VYW2	442-50VYW9
1 3/4" - 1 7/8" - 2"	3 1/2"			442-50V3YW9
1 7/8" - 2"	3 1/2"			443-50VYW9

\*FOR W-2 FLANGES, SPECIFY 4" OR 4 3/4" SPREAD ON CENTER BOLTS  
NOTE: ADD "SCH" TO THE FRONT OF ALL PART NUMBERS

TUBE DIAMETER	COLLECTOR DIAMETER	STANDARD MOPAR	W-2*	W-9
1 5/8" - 1 3/4"	3"	441-52VYR	441-52VYRW2	
1 5/8" - 1 3/4"	3"	441-52VYR	441-52VYRW2	
1 5/8" - 1 3/4" - 1 7/8"	3 1/2"	441-52V3YR	441-52V3YRW2	
1 3/4" - 1 7/8"	3 1/2"	442-52VYR	442-52VYRW2	442-52VYRW9
1 3/4" - 1 7/8" - 2"	3 1/2"			442-52V3YRW9
1 7/8" - 2"	3 1/2"			443-52VYRW9

\*FOR W-2 FLANGES, SPECIFY 4" OR 4 3/4" SPREAD ON CENTER BOLTS  
NOTE: ADD "SCH" TO THE FRONT OF ALL PART NUMBERS

\*NOTE: IF YOU ARE UNSURE WHICH STYLE OF HEADER FITS YOUR PARTICULAR CAR, CONSULT THE SCHOENFELD HEADERS CATALOG OR VISIT [WWW.SCHOENFELDHEADERS.COM](http://WWW.SCHOENFELDHEADERS.COM) FOR A MORE DETAILED DESCRIPTION

Place your order at (479) 646-6988, Fax to (479) 646-5939, or visit [www.southwestspeed.com](http://www.southwestspeed.com)



# SCHOENFELD HEADERS - SPRINT CAR FOR SMALL BLOCK CHEVY'S

- ★32" LONG PRIMARIES FOR MAXIMUM TORQUE & HORSEPOWER; 18 GAUGE TUBING; LONG COLLECTORS
- ★WELDED TO CLEAR 4" FROM HEAD TO INSIDE OF HEADER; GASKETS & BOLTS INCLUDED

TUBE DIAMETER	COLLECTOR DIA./LENGTH	STANDARD CHEVY	SPREAD PORT / D.N.	ALL PRO
1 5/8"	3" x 13"	SCH 1052L		
1 5/8" - 1 3/4"	3 1/2" x 13"	SCH 1052LV		
1 5/8" - 1 3/4"	3" x 13"	SCH 1052LV-3		
1 3/4"	3 1/2" x 13"	SCH 1054L	SCH 1054LSP	
1 3/4" - 1 7/8"	3 1/2" x 13"	SCH 1054LV	SCH 1054LVSP	
1 7/8"	3 1/2" x 13"	SCH 1055L	SCH 1055LDN	SCH 1055LAP
1 7/8" - 2"	3 1/2" x 13"	SCH 1055LV	SCH 1055LVDN	SCH 1055LVAP
2"	3 1/2" x 13"		SCH 1056LDN	SCH 1056LAP

-STRAIGHT TUBE DESIGN REMOVES 200° OF BEND COMPARED TO NORMAL HEADER TO INCREASE FLOW

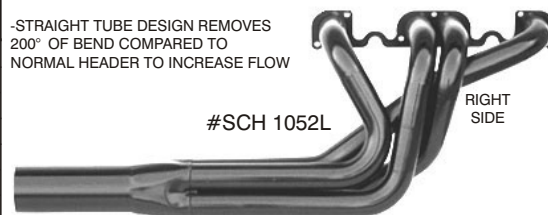

TUBE DIAMETER	COLLECTOR DIA./LENGTH	STANDARD CHEVY	SPREAD PORT / D.N.	ALL PRO
1 1/2" - 1 5/8"	3" x 13"	SCH 1021LV		
1 5/8"	3" x 13"	SCH 1022L		
1 5/8" - 1 3/4"	3 1/2" x 13"	SCH 1022LV		
1 3/4"	3 1/2" x 13"	SCH 1024L	SCH 1024LSP	
1 3/4" - 1 7/8"	3 1/2" x 13"	SCH 1024LV	SCH 1024LVSP	
1 7/8"	3 1/2" x 13"	SCH 1025L	SCH 1025LDN	SCH 1025LAP
1 7/8" - 2"	3 1/2" x 13"	SCH 1025LV	SCH 1025LVDN	SCH 1025LVAP
2"	3 1/2" x 13"		SCH 1026LDN	SCH 1026LAP

-FORWARD DESIGN GIVES EXTRA MUFFLER CLEARANCE

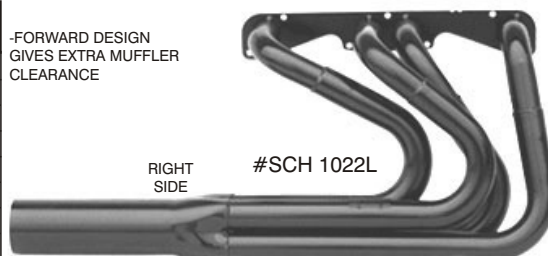

TUBE DIAMETER	COLLECTOR DIA./LENGTH	STANDARD CHEVY	COLLECTOR DIA./LENGTH	SPREAD PORT / D.N.
1 1/2" - 1 5/8"	3" x 8"	SCH 1011LV		
1 5/8"	3" x 8"	SCH 1012L		
1 5/8" - 1 3/4"	3 1/2" x 8"	SCH 1012LV		
1 5/8" - 1 3/4"	3" x 8"	SCH 1012LV-3		
1 3/4"	3 1/2" x 8"	SCH 1014L	3 1/2" x 13"	SCH 1014LSP
1 3/4" - 1 7/8"	3 1/2" x 9"	SCH 1014LV	3 1/2" x 13"	SCH 1014LVSP
1 7/8"	3 1/2" x 9"	SCH 1015L	3 1/2" x 13"	SCH 1015LDN
1 7/8" - 2"	3 1/2" x 9"	SCH 1015LV	3 1/2" x 13"	SCH 1015LVDN
2"			3 1/2" x 13"	SCH 1016LDN

-STANDARD DESIGN HAS SHORT COLLECTORS ON THE STANDARD CHEVY & LONG COLLECTORS ON THE SPREAD PORT / D.N.  
-CNC LASER CUT FLANGE ON THE SPREAD PORT TO CLEAR DOWN NOZZLES



## FOR SMALL BLOCK CHEVY'S - TRI-Y HEADERS

- ★4 INTO 2 INTO 1 CONFIGURATION FOR INCREASED TORQUE
- ★32" LONG PRIMARIES FOR MAXIMUM TORQUE & HORSEPOWER
- ★WELDED TO CLEAR 4" FROM HEAD TO INSIDE OF HEADER
- ★18 GAUGE TUBING; LONG COLLECTORS
- ★GASKETS & BOLTS INCLUDED

TUBE DIAMETER	COLLECTOR DIAMETER	STANDARD CHEVY	SPREAD PORT / D.N.
1 5/8" - 1 3/4"	3"	SCH 1062VY	
1 3/4" - 1 7/8"	3 1/2"	SCH 1064VY	SCH 1064VYSP
1 7/8" - 2"	3 1/2"	SCH 1065VY	SCH 1065VYDN

TUBE DIAMETER	COLLECTOR DIAMETER	STANDARD CHEVY	SPREAD PORT / D.N.
1 5/8" - 1 3/4"	3"	SCH 1022VY	
1 3/4" - 1 7/8"	3 1/2"	SCH 1024VY	SCH 1024VYSP
1 7/8" - 2"	3 1/2"	SCH 1025VY	SCH 1025VYDN

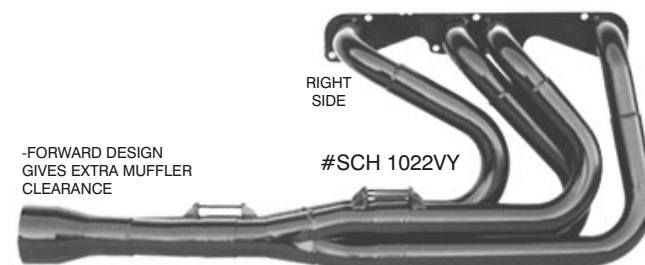
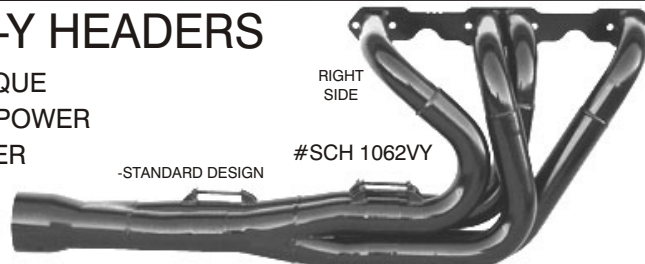

## FOR SMALL BLOCK CHEVY'S - ASPHALT SPRINTS

- ★32" LONG PRIMARIES FOR MAXIMUM TORQUE & HORSEPOWER
- ★18 GAUGE TUBING
- ★LONG COLLECTORS
- ★GASKETS & BOLTS INCLUDED

TUBE DIAMETER	COLLECTOR DIA./LENGTH	SPREAD PORT / D.N.
1 3/4" - 1 7/8"	3 1/2" x 13"	SCH 1034LVSP
1 7/8"	3 1/2" x 13"	SCH 1035LDN
1 7/8" - 2"	3 1/2" x 13"	SCH 1035LVDN
2"	3 1/2" x 13"	SCH 1036LDN

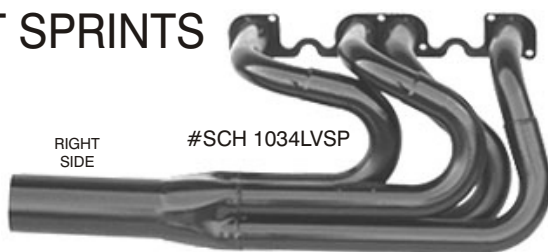

Place your order at (479) 646-6988, Fax to (479) 646-5939, or visit [www.southwestspeed.com](http://www.southwestspeed.com)

# SCHOENFELD HEADERS - SPRINT CAR

## FOR SMALL BLOCK CHEVY LS1-LS7 AND SB2

TUBE DIAMETER	COLLECTOR DIA./LENGTH	CHEVY LS1-LS7
1 5/8"	3" x 13"	SCH 1022L-LS1
1 5/8" - 1 3/4"	3 1/2" x 13"	SCH 1022LV-LS1
1 3/4"	3 1/2" x 13"	SCH 1024L-LS1
1 3/4"	3" x 13"	SCH 1024L-3LS1
1 3/4" - 1 7/8"	3 1/2" x 13"	SCH 1024LV-LS1

TUBE DIAMETER	COLLECTOR DIA./LENGTH	CHEVY SB2
1 3/4" - 1 7/8"	3 1/2" x 13"	SCH 1014LVSB2
1 7/8"	3 1/2" x 13"	SCH 1015LSB2
1 7/8" - 2"	3 1/2" x 13"	SCH 1015LVSB2

- ★32" LONG PRIMARIES
- ★FOR MAXIMUM TORQUE & HORSEPOWER
- ★LONG COLLECTORS
- ★GASKETS & BOLTS INCLUDED

#SCH 1022L-LS1  
-FORWARD DESIGN GIVES EXTRA MUFFLER CLEARANCE



#SCH 1014LVSB2  
-STANDARD DESIGN



## FOR SMALL BLOCK FORD'S

- ★32" LONG PRIMARIES FOR MAXIMUM TORQUE & HORSEPOWER; LONG COLLECTORS
- ★WELDED TO CLEAR 4" FROM HEAD TO INSIDE OF HEADER; GASKETS & BOLTS INCLUDED

TUBE DIAMETER	COLLECTOR DIA./LENGTH	WINDSOR/GT40 289-302-351	DART/"N" HEAD
1 5/8"	3" x 13"	SCH 3022L	SCH 3022LN
1 5/8" - 1 3/4"	3 1/2" x 13"	SCH 3022LV	SCH 3022LVN
1 3/4"	3 1/2" x 13"	SCH 3024L	SCH 3024LN
1 3/4" - 1 7/8"	3 1/2" x 13"	SCH 3024LV	SCH 3024LVN

-FORWARD DESIGN GIVES EXTRA MUFFLER CLEARANCE



## FOR BIG BLOCK CHEVY'S & BIG BLOCK FORD'S

TUBE DIAMETER	COLLECTOR DIA./LENGTH	BIG BLOCK CHEVY	BIG BLOCK FORD
2"	3 1/2" x 13"	SCH 2016A	
2"	4" x 13"	SCH 2016	SCH 6016
2 1/8"	4" x 13"	SCH 2017	SCH 6017
2 1/4"	4" x 13"	SCH 2018	

- ★LONG COLLECTORS
- ★GASKETS & BOLTS INCLUDED

#SCH 2016  
-STANDARD DESIGN



## FOR MOPAR'S

TUBE DIAMETER	COLLECTOR DIA./LENGTH	STANDARD MOPAR	W-2*	W-7	W-9
1 5/8"	3" x 13"	SCH 4052L	SCH 4052LW2		
1 5/8" - 1 3/4"	3 1/2" x 13"	SCH 4052LV	SCH 4052LVW2		
1 5/8" - 1 3/4"	3" x 13"	SCH 4052LV-3	SCH 4052LVW2-3		
1 3/4"	3 1/2" x 13"	SCH 4054L	SCH 4054LW2		
1 3/4" - 1 7/8"	3 1/2" x 13"	SCH 4054LV	SCH 4054LVW2		
1 7/8"	3 1/2" x 13"			SCH 4055LW7	SCH 4055LW9
1 7/8" - 2"	3 1/2" x 13"			SCH 4055LVW7	SCH 4055LVW9
2"	3 1/2" x 13"			SCH 4056LW7	SCH 4056LW9

\*FOR W-2 FLANGES, SPECIFY 4" OR 4 3/4" SPREAD ON CENTER BOLTS

- ★32" LONG PRIMARIES FOR MAX. TORQUE & H.P.
- ★LONG COLLECTORS
- ★WELDED TO CLEAR 4" FROM HEAD TO INSIDE OF HEADER

-STRAIGHT TUBE DESIGN REMOVES 200° OF BEND COMPARED TO NORMAL HEADER TO INCREASE FLOW

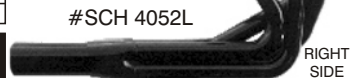

TUBE DIAMETER	COLLECTOR DIA./LENGTH	STANDARD MOPAR	W-2*	W-7	W-9
1 5/8"	3" x 13"	SCH 4022L	SCH 4022LW2		
1 5/8" - 1 3/4"	3 1/2" x 13"	SCH 4022LV	SCH 4022LVW2		
1 3/4"	3 1/2" x 13"	SCH 4024L	SCH 4024LW2		
1 3/4" - 1 7/8"	3 1/2" x 13"	SCH 4024LV	SCH 4024LVW2		SCH 4024LVW9
1 3/4" - 1 7/8"	3" x 13"	SCH 4024LV-3	SCH 4024LVW2-3		
1 7/8"	3 1/2" x 13"			SCH 4025LW7	SCH 4025LW9
1 7/8" - 2"	3 1/2" x 13"			SCH 4025LVW7	SCH 4025LVW9
2"	3 1/2" x 13"			SCH 4026LW7	SCH 4026LW9

\*FOR W-2 FLANGES, SPECIFY 4" OR 4 3/4" SPREAD ON CENTER BOLTS



## FOR MOPAR'S - TRI-Y HEADERS

- ★4 INTO 2 INTO 1 CONFIGURATION FOR INCREASED TORQUE
- ★32" LONG PRIMARIES FOR MAXIMUM TORQUE & HORSEPOWER

TUBE DIAMETER	COLLECTOR DIAMETER	MOPAR W-9	MOPAR W-9 RAISED PORT
1 3/4" - 1 7/8"	3 1/2"	SCH 4064VYW9	SCH 4064VYW9RP
1 7/8" - 2"	3 1/2"	SCH 4065VYW9	SCH 4065VYW9RP

#SCH 4064VYW9  
-STANDARD DESIGN

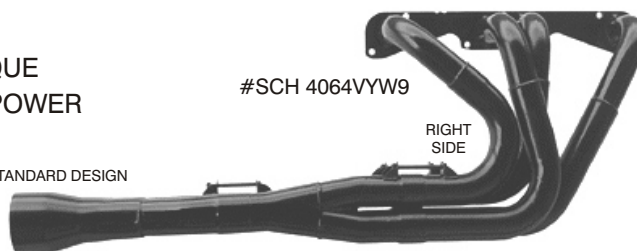

Place your order at (479) 646-6988, Fax to (479) 646-5939, or visit [www.southwestspeed.com](http://www.southwestspeed.com)

# SCHOENFELD HEADERS - MISC.

FOR FORD PINTO 2000CC & 2300CC; 4 CYL. 2.0 & 2.3

TUBE DIAMETER	COLLECTOR DIA./LENGTH	2300CC	2000CC
1 1/2" - 1 5/8"	3" x 8"	SCH F-234V	SCH F-204V
1 5/8" - 1 3/4"	3" x 8"	SCH F-235V	SCH F-205V
GASKETS		SCH FG-23	SCH FG-20

\*GASKET & BOLTS ARE INCLUDED FOR THE 2300CC

- ★ FITS TUBE CHASSIS STYLE OR GOES THROUGH FIREWALL ON PRODUCTION PINTO OR MUSTANG



#SCH F-234V

TUBE DIAMETER	COLLECTOR DIA./LENGTH	2300CC	2000CC
1 1/2" - 1 5/8"	3" x 8"	SCH F-238V	SCH F-208V
1 5/8" - 1 3/4"	3" x 8"	SCH F-239V	SCH F-209V
GASKETS		SCH FG-23	SCH FG-20

\*GASKET & BOLTS ARE INCLUDED FOR THE 2300CC

- ★ EXITS UNDER CAR ON PRODUCTION PINTO OR MUSTANG
- ★ THE MOTOR MOUNTS (ON 2.0) MAY HAVE TO BE MODIFIED TO FIT
- ★ ALSO FITS 83-92 FORD RANGER



#SCH F-238V

## FOR FORD PINTO - TRI-Y HEADERS

TUBE DIAMETER	COLLECTOR DIAMETER	2300CC	2000CC
1 1/2" - 1 5/8"	3"	SCH F-232VY	SCH F-202VY
1 5/8" - 1 3/4"	3"	SCH F-233VY	SCH F-203VY
GASKETS		SCH FG-23	SCH FG-20

\*GASKET & BOLTS ARE INCLUDED FOR THE 2300CC

- ★ FITS 4 CYLINDER 2.0 & 2.3
- ★ FITS TUBE CHASSIS STYLE OR GOES THROUGH FIREWALL ON PRODUCTION PINTO OR MUSTANG

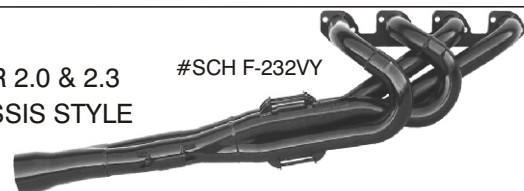

#SCH F-232VY

## FOR TOYOTA COROLLA

TUBE DIAMETER	COLLECTOR DIA./LENGTH	TOYOTA 1600 & 1800
1 1/2"	2 1/2" x 7"	SCH T168
1 1/2" - 1 5/8"	2 1/2" x 7"	SCH T168V

- ★ 1600CC & 1800CC TOYOTA
- ★ FITS 1971 TO 1981 CARINA HEMI REAR WHEEL DRIVE CARS
- ★ GASKET INCLUDED



#SCH T168V

## ZOOMIE GRASSBURNER HEADERS FOR SBC'S

TUBE DIAMETER	STANDARD CHEVY	SPREAD PORT / D.N.
1 5/8"	SCH 129	SCH 129SP
1 3/4"	SCH 130	SCH 130SP

- ★ FITS FRONT STEER CAMARO, CHEVELLE, ETC., & LATE MODEL, MODIFIEDS, ETC.
- ★ FITS STRAIGHT OR ANGLE PLUG HEADS
- ★ TUBES AREN'T WELDED INTO A COLLECTOR
- ★ GASKETS & BOLTS INCLUDED



LEFT SIDE

#SCH 129

## TRUCK / TRACTOR PULL HEADERS

TUBE DIAMETER	COLLECTOR DIA./LENGTH	STANDARD SB. CHEVY	SB. CHEVY SPREAD PORT
1 5/8"	3" x 8"	SCH 1512	
1 3/4"	3 1/2" x 8"	SCH 1514	SCH 1514SP
1 7/8"	3 1/2" x 9"	SCH 1515	SCH 1515SP

TUBE DIAMETER	COLLECTOR DIA./LENGTH	BIG BLOCK CHEVY
1 5/8"	3" x 8"	SCH 2512
2"	4" x 9"	SCH 2516
2 1/8"	4" x 10"	SCH 2517
2 1/4"	4" x 10"	SCH 2518

- ★ WILL NOT FIT POWER BRAKE BOOSTER
- ★ GASKETS & BOLTS INCLUDED

TUBE DIAMETER	COLLECTOR DIA./LENGTH	WINDSOR 289-302-351	DART/"N" HEAD
1 5/8"	3" x 8"	SCH 3512	SCH 3512N
1 3/4"	3 1/2" x 8"	SCH 3514	SCH 3514N

TUBE DIAMETER	COLLECTOR DIA./LENGTH	FORD 429-460
2"	4" x 10"	SCH 6516
2 1/8"	4" x 10"	SCH 6517

TUBE DIAMETER	COLLECTOR DIA./LENGTH	MOPAR 383-413-440
1 7/8"	3 1/2" x 9"	SCH 7515
2"	4" x 10"	SCH 7516



#SCH 1512

#SCH 2512

#SCH 3512

#SCH 6516

## DEMOLITION DERBY HEADERS

TUBE DIA.	STANDARD CHEVY	WINDSOR 289-302-351	MOPAR 318-340-360	MOPAR 361-383-440
1 5/8"	SCH 1522	SCH 3522	SCH 4522	
1 3/4"				SCH 7524

- ★ EXITS THROUGH HOOD
- ★ TUBES AREN'T WELDED INTO A COLLECTOR
- ★ GASKETS & BOLTS INCLUDED

#SCH 1522



Place your order at (479) 646-6988, Fax to (479) 646-5939, or visit [www.southwestspeed.com](http://www.southwestspeed.com)



# SCHOENFELD HEADERS - ACCESSORIES

**MUFFLERS**

- ★PRECISION, SCHOENFELD MUFFLERS ARE SOLD INDIVIDUALLY & ARE AVAILABLE IN NUMEROUS LENGTHS & DIAMETERS



LENGTH	OUTLET DIA.	INLET DIA.	BODY DIA.	PART #
6"	3"	3"	3 1/2"	SCH 63030
8"	3"	3"	3 1/2"	SCH 83030
12"	3"	3"	3 1/2"	SCH 123030
6"	3 1/2"	3 1/2"	4"	SCH 63535
8"	3 1/2"	3 1/2"	4"	SCH 83535
8"	3 1/2"	4"	4"	SCH 83540
9"	3"	3"	3 1/2"	SCH 92530
9"	3 1/2"	3 1/2"	4 3/8"	SCH 92535
10"	3 1/2"	3 1/2"	4"	SCH 103535K
12"	3 1/2"	3 1/2"	4"	SCH 123535
12"	3 1/2"	4"	4"	SCH 123540
18"	3 1/2"	3 1/2"	4"	SCH 183535
24"	3 1/2"	3 1/2"	4"	SCH 243535
27"	4"	4"	4 1/2"	SCH 273540

## SANCTION APPROVED MUFFLERS

- ★100 DECIBELS AT 100 FEET
- ★APPROVED BY NUMEROUS SANCTIONING BODIES



LENGTH	WEIGHT	OUTLET DIA.	INLET DIA.	BODY DIA.	PART #
11"	2.35#	3"	3"	3 1/2"	SCH 112530
11"	2.84#	3 1/2"	3 1/2"	4 3/8"	SCH 112535
11"	2.90#	3 1/2"	3 1/2"	4 3/8"	SCH 113035

## MODIFIED MUFFLERS



- ★REMOVES 9 DECIBELS OF SOUND
- ★MUFFLER SLIDES INTO 3" OR 3 1/2" COLLECTORS

LENGTH	WEIGHT	PART #
6"	1.28#	SCH 609

## INSERT MUFFLERS

- ★WITH ITS STRAIGHT THROUGH DESIGN, THE SCHOENFELD INSERT MUFFLER WILL REDUCE THE NOISE LEVEL WITHOUT EXCESS BACK PRESSURE
- ★LIGHTWEIGHT WITH NOTHING TO BURN OUT

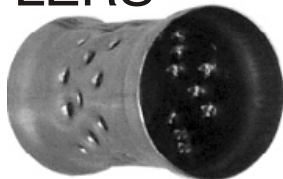

COLLECTOR DIAMETER	LENGTH	CORE DIA.	PART #
3"	4"	2 1/2"	SCH 42530
3 1/2"	4"	3"	SCH 43035
4"	4"	3 1/2"	SCH 43540

## TURNOUTS

- ★EXPANDED ON ONE END
- ★SLIP-ON DESIGN WITH A CLEAN, FINISHED LOOK
- ★DEFLECTS EXHAUST



DIA.	LENGTH	PART #
2 1/2"	10"	SCH 2525
3"	9 1/4"	SCH 3025
3 1/2"	9 1/4"	SCH 3525
4"	15"	SCH 4025

## ELBOWS

- ★MANDREL BENT ELBOWS
- ★ALL ELBOWS ARE EXPANDED ON THE "A" END
- ★SLIP-ON DESIGN

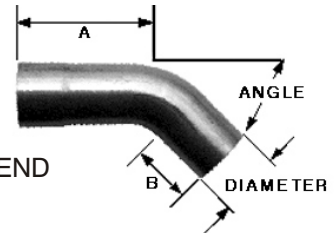

DIAMETER	ANGLE°	C.L.R.*	"A" LENGTH	"B" LENGTH	PART #
2 1/2"	45°	5 1/4"	6 1/2"	5"	SCH 2545
2 1/2"	90°	5 1/4"	5 3/4"	5 3/4"	SCH 2590
3"	30°	4"	6 1/2"	6 3/4"	SCH 3031
3"	30°	4"	15 1/2"	6"	SCH 3032
3"	42°	4"	10"	10"	SCH 3042
3"	45°	4"	5"	6"	SCH 3045
3"	80°	4"	5"	5 1/4"	SCH 3080
3"	90°	4"	5"	5 1/4"	SCH 3090
3 1/2"	30°	5"	6 1/4"	6"	SCH 3531
3 1/2"	30°	5"	15 1/2"	6"	SCH 3532
3 1/2"	42°	5"	10"	10"	SCH 3542
3 1/2"	45°	5"	6 1/2"	3 1/2"	SCH 3545
3 1/2"	80°	5"	5 1/4"	2 3/4"	SCH 3580
3 1/2"	90°	5"	5 1/4"	2 3/4"	SCH 3590
4"	90°	6"	8"	8"	SCH 4090

\*C.L.R. = CENTER LINE RADIUS

## REDUCERS



OUTSIDE DIA.	INSIDE DIA.	PART #
2 1/2"	3"	SCH 2530
2 1/2"	3 1/2"	SCH 2535
3"	3"	SCH 3030
3"	3 1/2"	SCH 3035
4"	3 1/2"	SCH 4035
3 1/2"	3"	SCH 3530
3 1/2"	3 1/2"	SCH 3535

## COLLECTOR INSERT REDUCERS

- ★SLIPS INSIDE THE COLLECTOR FOR ADDED TORQUE



COLLECTOR DIA.	INSIDE DIA.	PART #
3"	2 1/2"	SCH 42530NH
3 1/2"	3"	SCH 43035NH
4"	3 1/2"	SCH 43540NH

Place your order at (479) 646-6988, Fax to (479) 646-5939, or visit [www.southwestspeed.com](http://www.southwestspeed.com)

# SCHOENFELD HEADERS - ACCESSORIES

★SLIP-ON DESIGN

★EXTENSIONS ARE EXPANDED ON ONE END



LENGTH	2 1/2" DIA.	3" DIA.	3 1/2" DIA.	4" DIA.	5" DIA.
12"	120025	120030	120035	120040	120050
24"	240025	240030	240035	240040	240050
30"	300025	300030	300035	300040	300050
36"	360025	360030	360035	360040	360050
48"	480025	480030	480035	480040	480050

NOTE: ADD "SCH" TO THE FRONT OF ALL PART NUMBERS

## U-BENDS

★USED TO ALTER THAT HARD-TO-FIT HEADER

★ALL U-BENDS HAVE 9" LEGS, EXCEPT THE 2 1/4" DIAMETER BEND, WHICH HAS 7 1/2" LEGS



TUBE DIAMETER	BEND RADIUS	18 GAUGE TUBING (.049")	16 GAUGE TUBING (.065")
1 1/2"	2 1/2"		SCH 015016U
1 5/8"	2 1/2"	SCH 016218U	SCH 016216U
1 3/4"	2 1/2"	SCH 017518U	SCH 017516U
1 7/8"	3"	SCH 018718U	SCH 018716U
2"	3"	SCH 020018U	
2 1/8"	3"	SCH 021218U	
2 1/4"	3 1/2"	SCH 022518U	

## J-BENDS

★USED TO ALTER THAT HARD-TO-FIT HEADER

★ALL J-BENDS HAVE 3" & 15" LEGS



TUBE DIAMETER	BEND RADIUS	18 GAUGE TUBING (.049")	16 GAUGE TUBING (.065")
1 1/2"	2 1/2"		SCH 015016J
1 5/8"	2 1/2"	SCH 016218J	SCH 016216J
1 3/4"	2 1/2"	SCH 017518J	SCH 017516J
1 7/8"	3"	SCH 018718J	SCH 018716J
2"	3"	SCH 020018J	
2 1/8"	3"	SCH 021218J	
2 1/4"	3 1/2"	SCH 022518J	

## MISCELLANEOUS BENDS

★INCLUDES ALMOST EVERY BEND POSSIBLE  
 ★FOR THE DO-IT-YOURSELF HEADER BUILDER  
 ★GREAT FOR HARD-TO-FIT HEADERS  
 ★APPROXIMATELY 36' OF 18 GAUGE (.049") TUBING

TUBE DIA.	PART #
1 5/8"	SCH MB162
1 3/4"	SCH MB175
1 7/8"	SCH MB187
2"	SCH MB200
2 1/8"	SCH MB212
2 1/4"	SCH MB225

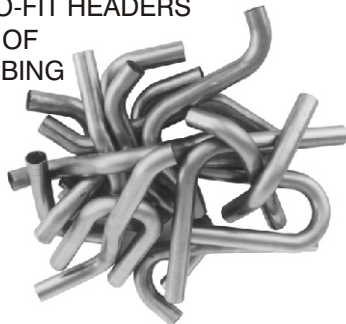

## GASKETS



ENGINE	PORT SHAPE	HOLE I.D.	PART #
SBC	ROUND	1 5/8"	SCH 01500
SBC	SQUARE	1 5/8"	SCH 01501
SBC	OVAL	1 7/8"	SCH 01510
SBC	D	1 7/8"	SCH 01511
SBC 18°/PRO ACT. 14°	S.A.P.*	2"	SCH 01540
SBC BRODIX SPREAD	D	1 7/8"	SCH 01533
SBC DOWN NOZZLE	ROUND	2 1/8"	SCH 01531
SBC LS1 - LS7	ROUND	1 3/4"	SCH 01780
SBC SB2	S.A.P.*	2"	SCH 01590
SBC CRATE MOTOR	D	1 3/4"	SCH 01560
BBC 396-454	ROUND	1 5/8"	SCH 0250
BBC 396-454	S.A.P.*	2"	SCH 02510
BBC 396-454	ROUND	2 1/4"	SCH 02520
FORD 289W-351W	S.A.P.*	1 3/4"	SCH 03500
FORD SVO "N"/ DART	S.A.P.*	1 3/4"	SCH 03520
BBF 429-460A	S.A.P.*	2 1/8"	SCH 06511
MOPAR	S.A.P.*	1 3/4"	SCH 04500
FORD PINTO 2000	OVAL	1 5/8"	SCH FG-20
FORD PINTO 2300	OVAL	1 5/8"	SCH FG-23
TOYOTA	S.A.P.*	1 1/2"	SCH TG-16

\*S.A.P. = SAME AS PORT. MEANING GASKET FITS UNIQUE PORT SHAPE  
 NOTE: MANY GASKETS WILL FIT PORTS SMALLER THAN ONES LISTED

## HEADER BOLTS

★HIGH STRENGTH BOLTS ARE SOLD INDIVIDUALLY & IN PACKS OF 8, 12, 14, & 16



DESCRIPTION	PART #
3/16" x 3/4" LONG, 3/8" HEX HEAD (12)	440-300
3/16" x 3/4" LONG, 3/8" HEX HEAD (14)	440-302
3/16" x 3/4" LONG, 3/8" HEX HEAD (16)	440-304
3/16" x 3/4" LONG, 5/16" HEX HEAD (EACH)	SCH 3000
5/16" x 3/4" LONG, 3/8" HEX HEAD* (12)	SCH 3003-12
10mm x 22mm PINTO (8)	SCH 3005-8

\*5/16" THREADED BOLTS ARE FOR MOPAR'S

## EXHAUST BOLTING TAB KITS

★TABS FOR BOLTING THE EXHAUST TOGETHER  
 ★1 KIT (#SCH 4003-1) INCLUDES 2 TABS, 1 BOLT, 1 LOCK NUT, & 2 LOCK WASHERS (AS SHOWN)



DESCRIPTION	PART #
1 TAB KIT W/ HARDWARE, 2 TABS	SCH 4003-1
2 TAB KITS W/ HARDWARE, 4 TABS	SCH 4003-2
4 TAB KITS W/ HARDWARE, 8 TABS	SCH 4003-4
6 TAB KITS W/ HARDWARE, 12 TABS	SCH 4003-6
12 WELD TABS ONLY	SCH 4001-12

## BODY EXHAUST FLANGE

★LASER CUT ALUMINUM  
 ★PROTECTS BODY PANELS FROM EXTREME EXHAUST HEAT



PART #220-412

Place your order at (479) 646-6988, Fax to (479) 646-5939, or visit [www.southwestspeed.com](http://www.southwestspeed.com)

# SCHOENFELD HEADERS - ACCESSORIES

## COLLECTORS

- ★SLIP-ON 4 TUBE COLLECTORS
- ★STYLES 6 ROTATED & 8 ROTATED  
HAVE THE SAME BEND AS STYLES 6 & 8, RESPECTIVELY, BUT THE TUBES ARE ROTATED AT A 45° ANGLE TO POINT THE EXHAUST AT THE GROUND
- ★STYLE 9H ALSO FEATURES 45° ROTATED TUBES TO POINT AT THE GROUND



SLIPS OVER	COL. DIA.	# OF TUBES	STYLE 3	STYLE 6	STYLE 6 ROTATED	STYLE 8	STYLE 8 ROTATED	STYLE 9	STYLE 9H
1 1/2"	3"	4	SO-53043	SO-53046	SO-53046R	SO-53048	SO-53048R	SO-53049	SO-53049H
1 5/8"	3"	4	SO-63043	SO-63046	SO-63046R	SO-63048	SO-63048R	SO-63049	SO-63049H
1 5/8"	3 1/2"	4	SO-63543	SO-63546	SO-63546R	SO-63548	SO-63548R	SO-63549	SO-63549H
1 3/4"	3 1/2"	4	SO-73543	SO-73546	SO-73546R	SO-73548	SO-73548R	SO-73549	SO-73549H
1 7/8"	3 1/2"	4	SO-83543	SO-83546	SO-83546R	SO-83548	SO-83548R	SO-83549	SO-83549H

NOTE: ADD "SCH" TO THE FRONT OF ALL PART NUMBERS

## COLLECTORS

- ★SLIP-ON & WELD-ON,  
3 & 4 TUBE COLLECTORS



SLIPS OVER	COL. DIA.	# OF TUBES	SLIP-ON STYLE 1	SLIP-ON STYLE 2	WELD-ON STYLE 0
1 1/2"	3"	3	SO-53031		WO-53030
1 5/8"	3"	3	SO-63031		WO-63030
1 3/4"	3"	3	SO-73031		WO-73030
1 7/8"	3"	3	SO-83031		WO-83030
2"	3"	3	SO-03031		WO-03030
1 1/2"	3"	4	SO-53041	SO-53042	WO-53040
1 5/8"	3"	4	SO-63041	SO-63042	WO-63040
1 3/4"	3"	4	SO-73041	SO-73042	WO-73040
1 5/8"	3 1/2"	4	SO-63541	SO-63542	WO-63540
1 3/4"	3 1/2"	4	SO-73541	SO-73542	WO-73540
1 7/8"	3 1/2"	4	SO-83541	SO-83542	WO-83540
2"	3 1/2"	4	SO-03541	SO-03542	WO-03540
2 1/8"	3 1/2"	4			WO-13540
2"	4"	4	SO-04041		WO-04040
2 1/8"	4"	4	SO-14041		WO-14040
2 1/4"	4"	4			WO-24040

NOTE: ADD "SCH" TO THE FRONT OF ALL PART NUMBERS

## COLLECTOR FLANGES & GASKETS

- ★WELDS TO THE HEADER & EXTENSION PIPES, SO THE EXHAUST CAN BE BOLTED & UNBOLTED WITH EASE



FLANGE I.D.	BOLT HOLES	FLANGE PART #	GASKET PART #
1 1/2"	2	SCH 150FR	
2 1/2"	3	SCH 250CR	SCH 250CG
3"	3	SCH 300CR	SCH 300CG
3 1/2"	3	SCH 350CR	SCH 350CG

## 2 x 1 COLLECTORS

- ★MERGES 2 PIPES INTO 1 FOR SUPERIOR SCAVENGING
- ★DESIGNED FOR EASY MUFFLER & TAILPIPE INSTALLATION

INLET DIA.	3" OUT	3 1/2" OUT	4" OUT	5" OUT
3" IN	Y-3030	Y-3035	Y-3040	Y-3050
3 1/2" IN		Y-3535	Y-3540	Y-3550

ADD "SCH" TO THE FRONT OF ALL PART #'S



## 2 x 2 COLLECTORS

- ★DESIGNED FOR EASY MUFFLER & TAILPIPE INSTALLATION
- ★TIES COLLECTORS TOGETHER TO EQUALIZE EXHAUST SCAVENGING

INLET DIA.	3" OUT	3 1/2" OUT
3" IN	X-3030	X-3035
3 1/2" IN	X-3530	X-3535

NOTE: ADD "SCH" TO THE FRONT OF ALL PART #'S



## HEADER WRAP

- ★SOLD IN 2" WIDE x 1/16" THICK ROLLS, EITHER 50' OR 100' LONG
- ★CONTAINS EXHAUST HEAT FOR BETTER VELOCITY & SCAVENGING MORE POWER, PLUS COOLER UNDER-HOOD TEMPERATURES
- ★ALSO USED TO INSULATE MUFFLERS, EXHAUST COLLECTORS & PIPES, OIL & FUEL LINES



DESCRIPTION	PART #
1/16" THICK x 2" WIDE x 50 FT. LONG	LON 64870
1/16" THICK x 2" WIDE x 100 FT. LONG	LON 64850

NOTE: FOR A CONSTANT STREAM OF NEW PRODUCTS & UP-TO-THE-SECOND PRICING, VISIT [WWW.SOUTHWESTSPEED.COM](http://WWW.SOUTHWESTSPEED.COM)

Place your order at (479) 646-6988, Fax to (479) 646-5939, or visit [www.southwestspeed.com](http://www.southwestspeed.com)



# STEERING & FRONT SUSPENSION BOLT KITS



- ★ COMPLETE BOLT KITS FOR BOTH RACING & EXACT OEM APPLICATIONS
- ★ KITS FIT 64-72 CHEVELLE, 67-81 CAMARO, & 68-72 NOVA, JUST TO NAME A FEW
- ★ ALL NECESSARY BOLTS, WASHERS, NUTS, SHIMS, ETC. ARE PROVIDED
- ★ CONTROL ARM BOLT KITS GIVE ENOUGH HARDWARE FOR A PAIR OF ARMS

DESCRIPTION	PART #
UPPER A-ARM KIT, OEM	101-0249
LOWER A-ARM KIT, RACING	101-7950
LOWER A-ARM KIT, OEM	101-7951
STEERING BOX KIT, RACING	105-3290
STEERING BOX KIT, OEM	105-3291
IDLER ARM KIT, RACING	107-2400
IDLER ARM KIT, OEM	107-2401

## PITMAN ARM NUT & WASHER

- ★ SHOULD FIT ANY GM STEERING BOX SHAFT

PART #107-1400



## GM CALIPER BOLTS

- ★ ONE OR TWO PIECE, HEAT TREATED BOLTS
- ★ REPLACES STOCK GM BOLTS & WILL WORK WITH GM METRIC & BIG GM CALIPERS
- ★ #105-0549 INCLUDES 2 CALIPER BOLTS & THE BOLTS & WASHERS TO PUT A GM METRIC CALIPER BRACKET (#105-055 OR #105-056) ON A PINTO SPINDLE



DESCRIPTION	PART #
1 PIECE CALIPER BOLT	203-099
2 PIECE CALIPER BOLT WITH BUSHING	203-098
PINTO SPINDLE/METRIC CALIPER KIT	105-0549

## BUMP STEER KITS SPACER KIT

- ★ TAPERED DESIGN
- ★ 2" BODY COMES WITH .100", .200", & .300" SPACERS
- ★ USED WITH 5/8" ROD END



PART #105-084

## GRADE 8 BOLT FOR SPACER KIT

- ★ COMES WITH JAM NUT
- ★ 5/8"-18 THREADS
- ★ 4 1/2" LONG
- ★ USED W/ 5/8" ROD END

PART #105-086

## STUD KITS

- ★ TAPERED DESIGN
- ★ ELIMINATES THE NEED TO DRILL THE SPINDLE
- ★ SOLD COMPLETE W/ NUTS & SPACERS



DESCRIPTION	PART #
METRIC SPINDLE, SHORT STUD	105-080
PINTO SPINDLE, LONG STUD	105-082

## BOLTS & SPACERS

- ★ USE WITH 5/8"-18 ROD ENDS
- ★ ADJUSTS BUMP STEER
- ★ SHIMS PRICED EACH & SOLD IN BAGS OF 10



DESCRIPTION	PART #
.050" BUMP STEER SHIM	105-064
.100" BUMP STEER SHIM	105-066
.150" BUMP STEER SHIM	105-067
.200" BUMP STEER SHIM	105-068
.250" BUMP STEER SHIM	105-069
.300" BUMP STEER SHIM	105-070
.350" BUMP STEER SHIM	105-072
5/8" x 3" SPINDLE BOLT (EACH), GRADE 8	105-060
5/8" x 4 1/2" BOLT & NUT (EACH), GRADE 8	105-086

## STARTER BOLT KITS

- ★ AVAILABLE TO BOLT STARTERS ON SBC BLOCK AND BRINN, BERT, & FALCON BELLHOUSINGS
- ★ COME W/ 2 BOLTS & 2 LOCK WASHERS



DESCRIPTION	PART #
KIT FOR SBC BLOCKS	499-8504
KIT FOR BRINN BELLHOUSINGS	499-8505
KIT FOR BERT & FALCON BELLHOUSINGS	499-8506

## ROTOR BOLT KITS

- ★ 5/16"-18 x 1" COARSE THREAD, ALLEN HEAD BOLTS OR 5/16"-24 x 7/8" FINE THREAD, 12 PT. BOLTS



- ★ SOLD W/ EITHER LOCK WASHERS OR LOCK NUTS

DESCRIPTION	PART #
FINE, 8 BOLT W/ LOCK WASHERS	203-104
COARSE, 8 BOLT W/ LOCK WASHERS	203-106
COARSE, 10 BOLT W/ LOCK WASHERS	203-108
COARSE, 8 BOLT W/ LOCK NUTS	203-110
COARSE, 10 BOLT W/ LOCK NUTS	203-112

Place your order at (479) 646-6988, Fax to (479) 646-5939, or visit [www.southwestspeed.com](http://www.southwestspeed.com)

# FLYWHEEL, FLEXPLATE, & COUPLER BOLT KITS

- ★HIGH STRENGTH 12 POINT BOLTS
- ★SOLD IN SETS OF 6
- ★3 DIFFERENT SETS AVAILABLE



- ★650-0017: 7/16"-20 x 7/8"
- ★650-001 : 7/16"-20 x 1"
- ★650-048 : 7/16"-20 x 1 1/4"

APPLICATION	USE #
BRINN BELLHOUSING KIT WITH BRINN FLYWHEEL	650-001
BRINN DIRECT DRIVE COUPLER WITH FLEXPLATE	650-048
BERT BELLHOUSING KIT WITH BERT FLYWHEEL	650-048
BERT DIRECT DRIVE COUPLER WITH FLEXPLATE	650-001
FALCON BELLHOUSING KIT W/ FALCON FLYWHEEL	650-0017
FALCON DIRECT DRIVE COUPLER WITH FLEXPLATE	650-0017
QUARTERMASTER, RAM, TILTON, ETC. MINI-CLUTCH WITH FLEXPLATE	650-0017
STOCK-TYPE STEEL FLYWHEEL	650-0017

# PRESSURE PLATE BOLT KIT



- ★3/8"-16 x 1" LONG, 12 POINT BOLTS
  - ★SOLD IN SETS OF 6
- PART #650-594**

# 9" FORD RING GEAR BOLT KITS

- ★EXTRA-SMALL HEADS TO FIT ALL SPOOLS
- ★SOLD IN PACKS OF 10



DESCRIPTION	PART #
7/16"-20 x 1" LONG, 12 POINT BOLT SET	603-328
7/16"-20 x 7/8" LONG, 12 POINT BOLT SET	603-3287

# QUICK CHANGE RING GEAR BOLT KITS

- ★#604-142 IS USED WHEN BOLTS GO THROUGH THE RING GEAR HOLES & TAKE NUTS ON THE OTHER SIDE
- ★#604-144 IS USED WHEN BOLTS SCREW-IN THE THREADED RING GEAR
- ★SOLD IN PACKS OF 12



DESCRIPTION	PART #
Q.C. RING GEAR BOLT & NUT SET (12)	604-142
Q.C. RING GEAR BOLT SET (12)	604-144

# AXLE SPACER BOLTS

- ★3/4" LONG, POINTED AXLE SPACER BOLTS
- ★COARSE & FINE THREAD AVAILABLE



DESCRIPTION	PART #
3/8"-16 COARSE POINTED BOLT	605-992
3/8"-24 FINE POINTED BOLT	605-993

# MOTOR MOUNT BOLT KIT

- ★HIGH QUALITY, SBC FRONT MOTOR MOUNT KIT
- ★6 BOLTS PER PACK



**PART #440-200**

# CARBURETOR STUD KITS



- ★EACH KIT COMES WITH 4 STUDS, 4 WASHERS, & 4 NUTS

DESCRIPTION	PART #
CARBURETOR STUD KIT, 1 3/8"	410-910
CARBURETOR STUD KIT, 2"	410-911
CARBURETOR STUD KIT, 2 1/2"	410-912
CARBURETOR STUD KIT, 3 3/8"	410-913

# VALVE COVER STUD & NUT SET

- ★WIDE SHOULDER NUTS PROVIDE EVEN TORQUE ON GASKETS
- ★GREAT FOR USE WHEN SPACE IS CRITICAL OR IF THE VALVE COVER NUTS MUST BE SNUGGED DOWN TIGHTER THAN WING NUTS WILL ALLOW
- ★INCLUDES EIGHT CHROME-PLATED STEEL 1/2" HEX HEAD X 1 3/8" LONG NUTS AND EIGHT 1/4"-20 X 1 3/8" LONG STUDS
- ★SBC LT SERIES BOLT KIT AVAILABLE (#411-390)



**PART #411-392**

# HEAD STUD KITS & BOLT KITS

- ★MADE FROM AIRCRAFT QUALITY 8740 HIGH TENSILE STRENGTH CHROMEMOLY STEEL, WHICH CAN WITHSTAND UP TO 190,000 PSI
- ★SBC, BBC, CHEVY LS1, SBF, BBF, CHRYSLER, & HOLDEN AVAILABLE
- ★EACH KIT COMES COMPLETE WITH HARDWARE

SEE PAGE 91

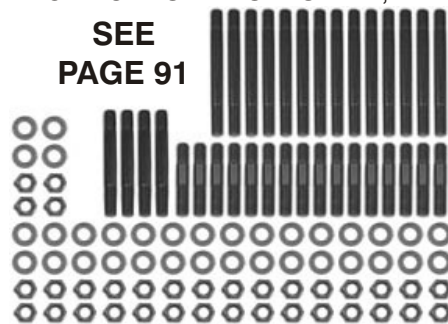

# HEADER BOLTS

- ★HIGH STRENGTH BOLTS ARE SOLD INDIVIDUALLY & IN PACKS OF 8, 12, 14, & 16



DESCRIPTION	PART #
3/16" x 3/4" LONG, 3/8" HEX HEAD (12)	440-300
3/16" x 3/4" LONG, 3/8" HEX HEAD (14)	440-302
3/16" x 3/4" LONG, 3/8" HEX HEAD (16)	440-304
3/16" x 3/4" LONG, 5/16" HEX HEAD (EACH)	SCH 3000
5/16" x 3/4" LONG, 3/8" HEX HEAD* (12)	SCH 3003-12
10mm x 22mm PINTO (8)	SCH 3005-8

\*5/16" THREADED BOLTS ARE FOR MOPAR'S

Place your order at (479) 646-6988, Fax to (479) 646-5939, or visit [www.southwestspeed.com](http://www.southwestspeed.com)



# FLAT BOLT SPACERS

BORE	O.D.	THICK	STEEL #	ALUM. #
3/16"	5/16"	.062"	503-8061	503-8081
3/16"	5/16"	.125"	503-8062	503-8082
3/16"	5/16"	.187"	503-8063	503-8083
3/16"	5/16"	.250"	503-8064	503-8084
3/16"	5/16"	.312"	503-8065	503-8085
3/16"	5/16"	.375"	503-8066	503-8086
3/16"	5/16"	.437"	503-8067	503-8087
3/16"	5/16"	.500"	503-8068	503-8088
3/16"	5/16"	.562"	503-8069	503-8089
3/16"	5/16"	.625"	503-8070	503-8090
3/16"	5/16"	.687"	503-8071	503-8091
3/16"	5/16"	.750"	503-8072	503-8092
3/16"	5/16"	.875"	503-8074	503-8094
3/16"	5/16"	1.000"	503-8076	503-8096
1/4"	1/2"	.062"	503-8101	503-8121
1/4"	1/2"	.125"	503-8102	503-8122
1/4"	1/2"	.187"	503-8103	503-8123
1/4"	1/2"	.250"	503-8104	503-8124
1/4"	1/2"	.312"	503-8105	503-8125
1/4"	1/2"	.375"	503-8106	503-8126
1/4"	1/2"	.437"	503-8107	503-8127
1/4"	1/2"	.500"	503-8108	503-8128
1/4"	1/2"	.562"	503-8109	503-8129
1/4"	1/2"	.625"	503-8110	503-8130
1/4"	1/2"	.687"	503-8111	503-8131
1/4"	1/2"	.750"	503-8112	503-8132
1/4"	1/2"	.875"	503-8114	503-8134
1/4"	1/2"	1.000"	503-8116	503-8136
5/16"	5/8"	.062"	503-8141	503-8161
5/16"	5/8"	.125"	503-8142	503-8162
5/16"	5/8"	.187"	503-8143	503-8163
5/16"	5/8"	.250"	503-8144	503-8164
5/16"	5/8"	.312"	503-8145	503-8165
5/16"	5/8"	.375"	503-8146	503-8166
5/16"	5/8"	.437"	503-8147	503-8167
5/16"	5/8"	.500"	503-8148	503-8168
5/16"	5/8"	.562"	503-8149	503-8169
5/16"	5/8"	.625"	503-8150	503-8170
5/16"	5/8"	.687"	503-8151	503-8171
5/16"	5/8"	.750"	503-8152	503-8172
5/16"	5/8"	.875"	503-8154	503-8174
5/16"	5/8"	1.000"	503-8156	503-8176
3/8"	5/8"	.062"	503-8181	503-8201
3/8"	5/8"	.125"	503-8182	503-8202
3/8"	5/8"	.187"	503-8183	503-8203
3/8"	5/8"	.250"	503-8184	503-8204
3/8"	5/8"	.312"	503-8185	503-8205
3/8"	5/8"	.375"	503-8186	503-8206
3/8"	5/8"	.437"	503-8187	503-8207
3/8"	5/8"	.500"	503-8188	503-8208
3/8"	5/8"	.562"	503-8189	503-8209
3/8"	5/8"	.625"	503-8190	503-8210
3/8"	5/8"	.687"	503-8191	503-8211
3/8"	5/8"	.750"	503-8192	503-8212
3/8"	5/8"	.875"	503-8194	503-8214
3/8"	5/8"	1.000"	503-8196	503-8216
3/8"	5/8"	1.125"	503-8198	503-8218
3/8"	5/8"	1.250"	503-8200	503-8220
3/8"	1/2"	.062"	503-9501	-
3/8"	1/2"	.125"	503-9502	-
3/8"	1/2"	.187"	503-9503	-
3/8"	1/2"	.250"	503-9504	-
3/8"	1/2"	.312"	503-9505	-
3/8"	1/2"	.375"	503-9506	-
3/8"	1/2"	.437"	503-9507	-
3/8"	1/2"	.500"	503-9508	-
3/8"	1/2"	.562"	503-9509	-
3/8"	1/2"	.625"	503-9510	-
3/8"	1/2"	.687"	503-9511	-
3/8"	1/2"	.750"	503-9512	-
3/8"	1/2"	.875"	503-9514	-
3/8"	1/2"	1.000"	503-9516	-
3/8"	5/8"	.312"	-	503-820
3/8"	3/4"	1.312"	-	503-8009
7/16"	9/16"	.062"	503-9520	-
7/16"	9/16"	.125"	503-9521	-
7/16"	9/16"	.187"	503-9522	-
7/16"	9/16"	.250"	503-9523	-
7/16"	9/16"	.312"	503-9524	-
7/16"	9/16"	.375"	503-9525	-
7/16"	9/16"	.437"	503-9526	-
7/16"	9/16"	.500"	503-9527	-
7/16"	9/16"	.562"	503-9528	-
7/16"	9/16"	.625"	503-9529	-
7/16"	9/16"	.687"	503-9530	-
7/16"	9/16"	.750"	503-9531	-
7/16"	9/16"	.875"	503-9533	-
7/16"	9/16"	1.000"	503-9535	-
7/16"	5/8"	.625"	503-995	-
7/16"	3/4"	.062"	503-8221	503-8241
7/16"	3/4"	.125"	503-8222	503-8242
7/16"	3/4"	.187"	503-8223	503-8243
7/16"	3/4"	.250"	503-8224	503-8244
7/16"	3/4"	.312"	503-8225	503-8245
7/16"	3/4"	.375"	503-8226	503-8246
7/16"	3/4"	.437"	503-8227	503-8247
7/16"	3/4"	.500"	503-8228	503-8248
7/16"	3/4"	.562"	503-8229	503-8249
7/16"	3/4"	.625"	503-8230	503-8250
7/16"	3/4"	.687"	503-8231	503-8251
7/16"	3/4"	.750"	503-8232	503-8252
7/16"	3/4"	.875"	503-8234	503-8254
7/16"	3/4"	1.000"	503-8236	503-8256
7/16"	1"	2.400"	-	504-210

BORE	O.D.	THICK	STEEL #	ALUM. #
1/2"	3/4"	.062"	503-998	503-8291
1/2"	3/4"	.125"	503-999	503-8292
1/2"	3/4"	.187"	504-000	503-8293
1/2"	3/4"	.250"	504-0001	503-8294
1/2"	3/4"	.312"	504-0009	503-8295
1/2"	3/4"	.375"	504-001	503-8296
1/2"	3/4"	.437"	504-0011	503-8297
1/2"	3/4"	.500"	504-002	503-8298
1/2"	3/4"	.562"	504-0029	503-8299
1/2"	3/4"	.625"	504-003	503-8300
1/2"	3/4"	.687"	504-0039	503-8301
1/2"	3/4"	.750"	504-004	503-8302
1/2"	3/4"	.875"	504-005	503-8304
1/2"	3/4"	1.000"	504-006	503-8306
1/2"	3/4"	1.125"	504-007	-
1/2"	3/4"	1.250"	504-008	-
1/2"	3/4"	1.375"	504-009	503-829
1/2"	3/4"	1.500"	504-010	-
1/2"	3/4"	4.875"	504-0117	-
1/2"	7/8"	1.250"	-	504-080
1/2"	1"	1.000"	-	503-8310
1/2"	1"	2.000"	-	503-8318
1/2"	1 1/2"	.750"	-	503-8328
5/8"	7/8"	.062"	504-0120	503-835
5/8"	7/8"	.125"	504-0121	503-836
5/8"	7/8"	.187"	504-0122	503-837
5/8"	7/8"	.250"	504-0123	503-838
5/8"	7/8"	.375"	504-0124	503-839
5/8"	7/8"	.500"	504-0125	503-840
5/8"	7/8"	.625"	504-0126	503-841
5/8"	7/8"	.750"	504-0127	503-842
5/8"	7/8"	.875"	504-0128	503-843
5/8"	7/8"	1.000"	504-0129	503-844
5/8"	1"	.357"	504-0132	-
3/4"	1"	.062"	504-015	503-849
3/4"	1"	.125"	504-016	503-850
3/4"	1"	.187"	504-017	503-851
3/4"	1"	.200"	504-019	-
3/4"	1"	.250"	504-0191	503-852
3/4"	1"	.300"	504-020	-
3/4"	1"	.375"	504-021	503-854
3/4"	1"	.500"	504-023	503-856
3/4"	1"	.625"	504-025	503-858
3/4"	1"	.750"	504-027	503-860
3/4"	1"	.875"	504-0275	503-862
3/4"	1"	1.000"	504-028	503-864
3/4"	1"	1.125"	504-029	503-866
3/4"	1"	1.250"	504-030	503-868
3/4"	1"	1.375"	-	503-870
3/4"	1"	1.500"	-	503-872
3/4"	1"	4.875"	504-0317	-

- ★ FLAT SPACERS TAKE UP SPACE BETWEEN BRACKETS
- ★ FLAT ON BOTH ENDS
- ★ PRICED EACH & SOLD IN PACKS OF 10



- ★ "A" = REDUCERS THAT FIT ENTIRELY IN THE ROD END BALL
- ★ "B" = REDUCERS THAT SLIP IN THE SIDES OF THE ROD END BALL OR OTHER MOUNTING HOLE
- ★ AVAILABLE FOR 5/8" & 3/4" BORE ROD ENDS OR MOUNTING HOLES
- ★ PRICED EACH & SOLD IN PACKS OF 10



DESCRIPTION	"A" #	"B" #
REDUCES 5/8" BORE TO 1/2" BOLT, ALUM.	504-193	504-051
REDUCES 5/8" BORE TO 1/2" BOLT, STEEL	504-194	504-050
REDUCES 3/4" BORE TO 1/2" BOLT, ALUM.	504-195	504-060
REDUCES 3/4" BORE TO 1/2" BOLT, STEEL	504-196	504-059
REDUCES 3/4" BORE TO 5/8" BOLT, ALUM.	504-197	504-065
REDUCES 3/4" BORE TO 5/8" BOLT, STEEL	504-198	504-064

# TAPERED BOLT SPACERS

- ★ FOR SPACING ROD ENDS AWAY FROM BRACKETS
- ★ ALL SPACERS ARE PRICED EACH; #504-110 & #504-100 ARE SOLD IN PACKS OF 8, ALL OTHERS ARE SOLD IN PACKS OF 10
- ★ THE "TAP" DESIGNATES THAT THE OUTSIDE IS TAPERED

BORE	O.D.	THICK	STEEL #	ALUM. #
3/16"	7/16" TAP.	.250"	503-7272	503-7472
1/4"	1/2" TAP.	.250"	503-7275	503-7475
5/16"	5/8" TAP.	.312"	503-728	503-748
3/8"	3/4" TAP.	.312"	503-730	503-750
7/16"	3/4" TAP.	.375"	503-731	503-751
1/2"	7/8" TAP.	.375"	503-732	503-752
1/2"	7/8" TAP.	.500"	503-7321	503-7521
5/8"	1" TAP.	.375"	503-734	503-754
5/8"	1" TAP.	.437"	504-110	504-100
3/4"	1 1/4" TAP.	.750"	504-1026	-
3/4"	1 1/4" TAP.	1.500"	-	504-1029
3/4"	1 3/8" TAP.	.437"	503-736	503-756
3/4"	1 1/2" TAP.	.500"	-	503-900
3/4"	1 1/2" TAP.	.625"	-	503-902
3/4"	1 1/2" TAP.	.750"	-	503-904
3/4"	1 1/2" TAP.	.875"	-	503-906
3/4"	1 1/2" TAP.	1.000"	-	503-908
3/4"	1 1/2" TAP.	1.125"	-	503-910
3/4"	1 1/2" TAP.	1.250"	-	503-912
3/4"	1 1/2" TAP.	1.375"	-	503-914
3/4"	1 1/2" TAP.	1.500"	-	503-916
3/4"	1 1/2" TAP.	1.625"	-	503-918
3/4"	1 1/2" TAP.	1.750"	-	503-920
3/4"	1 1/2" TAP.	1.875"	-	503-922
3/4"	1 1/2" TAP.	2.000"	-	503-924



# ROD END REDUCERS

- ★ USED TO REDUCE ROD END BORES OR OTHER MOUNTING HOLES
- ★ AVAILABLE IN 2 DIFFERENT STYLES:

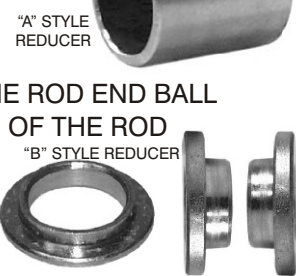

# HIGH MISALIGNMENT SPACERS

- ★ ALLOWS ROD ENDS TO WORK AT THE MOST ADVERSE ANGLES
- ★ "SLEEVE O.D." REPRESENTS THE BALL THAT THE SPACER WILL SLIP IN & "LIP WIDTH" IS THE EXTRA WIDTH THAT THE SPACER STICKS OUT FROM THE ROD END BALL



BORE	SLEEVE O.D.	LIP WIDTH	STEEL #	ALUM. #
1/4"	5/16"	.330"	503-764	503-784
1/4"	3/8"	.360"	503-766	503-786
5/16"	3/8"	.360"	503-768	503-788
5/16"	7/16"	.400"	503-769	503-789
3/8"	1/2"	.430"	503-770	503-790
1/2"	5/8"	.490"	503-772	503-792
1/2"	3/4"	.510"	503-774	503-794
5/8"	3/4"	.510"	503-776	503-796
1/2"	1"	.810"	503-7764	503-7964
5/8"	1"	.810"	503-7766	503-7966
3/4"	1"	.810"	503-7767	503-7967

- ★ PRICED EACH & SOLD IN PACKS OF 10

Place your order at (479) 646-6988, Fax to (479) 646-5939, or visit [www.southwestspeed.com](http://www.southwestspeed.com)



## PRO-BLEND PREMIUM HOT LAP TIRE SOFTENER - UNDETECTABLE

- ★PRO-BLEND HOT LAP TIRE SOFTENER IS THE UNDISPUTED TRACK CHAMPION
- ★DOESN'T "GIVE UP" AFTER A FEW LAPS; IT COMES IN WITH THE FIRST HEAT CYCLE & STAYS CONSISTENT THROUGHOUT A 200 LAP SHOW
- ★TOUTED BY PRO-BLEND AS "THE SINGLE MOST BENEFICIAL RACE PRODUCT YOU CAN BUY"
- ★GOOD FOR USE ON DIRT & ASPHALT
- ★REDUCES LAP TIME 2-5 TENTHS
- ★CORNER SPEEDS INCREASE 3-5 MPH
- ★INCREASES TIRE LIFE UP TO 50%
- ★TIRES WILL RUN 20-27° COOLER
- ★MUCH LESS CHANCE OF BLISTERING
- ★WON'T AFFECT BLEEDERS
- ★FOR USE ON INSIDE OR OUTSIDE OF TIRE
- ★SOLD IN 1 GALLON CANS; 1 GALLON SHOULD TREAT TIRES FOR 4 RACING WEEKENDS

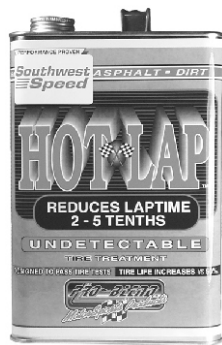

**PART**

**#PBM 7000TS**

## HOT LAP 2 TIRE SOFTENER - UNDETECTABLE

- ★HIGH-QUALITY PRODUCT AT A BUDGET PRICE
- ★DESIGNED FOR RUNNING A TOTAL OF 25 LAPS OR LESS
- ★GOOD FOR USE ON DIRT & ASPHALT
- ★REDUCES LAP TIME 2-5 TENTHS
- ★CORNER SPEEDS INCREASE 3-5 MPH
- ★INCREASES TIRE LIFE UP TO 50%
- ★TIRES WILL RUN 18-22° COOLER
- ★FOR USE ON INSIDE OR OUTSIDE OF TIRE
- ★SOLD IN 1 GALLON CANS; 1 GALLON SHOULD TREAT TIRES FOR 4 RACING WEEKENDS



**PART**

**#PBM 6000**

## PRO-BLEND TIRE CLEANER

- ★CLEANS SURFACES AND "OPENS" PORES OF THE TIRE
- ★THE MOLD RELEASE OR "GLAZE" FOUND ON STICKER TIRES NEEDS TO BE PROPERLY REMOVED BEFORE APPLYING TIRE SOFTENER
- ★ALSO GREAT FOR USE BETWEEN RACES
- ★SOLD IN 30 OUNCE CANS



**PART #PBM 7050**

## PRO-BLEND VICTORY LANE TIRE SOFTENER

- ★VICTORY LANE TIRE SOFTENER IS DETECTABLE
- ★DESIGNED FOR RUNNING 50 TO 100 LAPS
- ★GREAT FOR SHORT TRACK USE, BOTH DIRT & ASPHALT
- ★REDUCES LAP TIME 2-5 TENTHS
- ★CORNER SPEEDS INCREASE 3-5 MPH
- ★INCREASES TIRE LIFE UP TO 50%
- ★TIRES WILL RUN 18-22° COOLER
- ★GUARANTEED NOT TO "GIVE UP" AFTER A FEW LAPS
- ★DRAMATICALLY IMPROVES QUALIFYING
- ★SOLD IN 1 GALLON CANS; 1 GALLON SHOULD TREAT TIRES FOR 4 RACING WEEKENDS

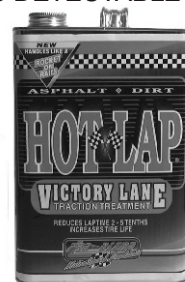

**PART**

**#PBM 5000**

## DRAG RACING TIRE TREATMENT

- ★PRO-BLEND DRAG RACING TIRE TREATMENT WILL IMPROVE 60 FOOT TIMES
- ★REDUCES E.T. UP TO 2 TENTHS
- ★TIRES RUN MUCH COOLER & LAST UP TO 40% LONGER
- ★UP TO 50% LESS BURNOUT TIME REQUIRED
- ★SHOULD GIVE INSTANT RESULTS
- ★SOLD IN 1 GALLON CANS
- ★FOR MAXIMUM RESULTS, CLEAN THE GLAZE OFF NEW TIRES BEFORE TREATMENT WITH PRO-BLEND TIRE CLEANER #PBM 7050; THIS SHOULD BE WORTH ANOTHER 1/2 OF A TENTH



**PART**

**#PBM 6070**

## ROCK CRAWLING TIRE TREATMENT

- ★PRO-BLEND OFF-ROAD TIRE TREATMENT ENABLES TIRES TO GET MORE GRIP
- ★SOFTENS TIRES A SMALL AMOUNT AS WELL FOR EVEN MORE GRIP
- ★SHOULD GIVE INSTANT RESULTS
- ★SOLD IN 1 GALLON CANS

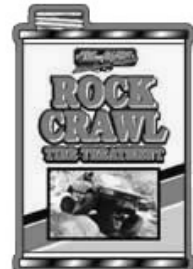

**PART #PBM 5060**

## PRO-BLEND GEAR LUBE

- ★ELIMINATES TRANSMISSION AND REAR END HEAT AND FAILURE
- ★REDUCES GEAR LUBE TEMPERATURE BY 60°
- ★TRIPLES GEAR LIFE IN REAR END AND TRANSMISSIONS
- ★SOLD IN 16 OUNCE CANS



**PART #PBM 8398**

Place your order at (479) 646-6988, Fax to (479) 646-5939, or visit [www.southwestspeed.com](http://www.southwestspeed.com)

## PRO-BLEND 40 BELOW



- ★REDUCES COOLANT TEMP. UP TO 40°
- ★IMPROVES COOLING IN CARS WITH RESTRICTED AIR FLOW
- ★TWO CANS PROVIDE BEST RESULTS
- ★KEEPS ENGINE COOL WHILE IDLING
- ★SOLD IN 32 OUNCE CANS

**PART #PBM 4032**

## STOPS OVERHEATING

- ★MAKES COOLANT A BETTER HEAT CONDUCTOR
- ★DEVELOPED FOR NASCAR FOR RUNNING UNDER EXTREME HEAT
- ★REDUCES WATER TEMPERATURE BY AS MUCH AS 40°
- ★SOLD IN 32 OUNCE CANS



**PART #PBM 4033**

## AUTO. TRANSMISSION TREATMENT



- ★ELIMINATES FLUID FOAMING
- ★FREES STICKING VALVE BODIES
- ★IMPROVES SHIFTING
- ★COOLS TRANSMISSION FLUID
- ★INCREASES TRANSMISSION LIFE
- ★SOLD IN 12 OZ. PLASTIC BOTTLES

**PART #PBM 4000**

## MANUAL TRANSMISSION TREATMENT

- ★INSTANTLY COOLS GEAR LUBE UP TO 60 DEGREES
- ★ELIMINATES NOISE, HEAT, AND WEAR
- ★IMPROVES SHIFTING
- ★DO NOT MIX WITH POSI-LUBE
- ★SOLD IN 12 OZ. PLASTIC BOTTLES

**PART #PBM 8888**



## POWER STEERING LUBE



- ★COOLS POWER STEERING FLUID TEMPERATURES
- ★EXTENDS PUMP & RACK AND PINION LIFE
- ★SOLD IN 6 1/2 OZ. PLASTIC BOTTLES

**PART #PBM 1735**

## ANTI-SEIZE

- ★A PLEASURE TO USE
- ★WITH A CONSISTENCY OF WARM HONEY, THIS PRODUCT DEFIES CONTACT OF DISSIMILAR OR LIKE METALS
- ★NOT AFFECTED BY HEAT, MOISTURE, SALT WATER, OR CORROSION
- ★SOLD IN 4 OUNCE PLASTIC BOTTLES



**PART #PBM 1720**

## PRO-BLEND CTX-2 RACING FUEL ADDITIVE



- ★PRO-BLEND CTX-2 UNDETECTABLE FUEL ADDITIVE CAN ADD UP TO 40 CONFIDENTIAL HORSEPOWER
- ★PRODUCES STRONG MID-RANGE TORQUE
- ★DESIGNED TO PASS FUEL TESTS
- ★VERY USER-FRIENDLY
- ★EXTREMELY CONSISTENT
- ★AN ABSOLUTE MUST FOR QUALIFYING
- ★FOR THE FUEL CHECKS, IT HAS NO EFFECT ON THE ELECTRIC METER AND FOR THE SPECIFIC GRAVITY, 1 GALLON OF CTX-2 IN 4 GALLONS OF RACING GAS INCREASES THE S.G. ABOUT .035, WHICH SHOULD KEEP IT UNDER THE LIMITS OF MOST SANCTIONS
- ★SOLD IN 1 GALLON CANS

**PART #PBM 1650**

## OCTANE BOOST



- ★INCREASES MID-RANGE TORQUE
- ★USE WITH GAS OR ALCOHOL
- ★MIX 16 OZ. CAN WITH 10 GAL. FUEL
- ★WILL NOT PASS FUEL CHECKS
- ★SOLD IN 16 OUNCE CANS

**PART #PBM 1616**

## ENGINE RACING CONCENTRATE

- ★THIS METAL TREATMENT MAKES ENGINES VIRTUALLY INDESTRUCTIBLE
- ★REDUCES OIL TEMPERATURE UP TO 60° AT THE CRANKSHAFT
- ★ALLOWS ENGINE TO RUN MUCH LONGER W/O DAMAGE SHOULD OIL PRESSURE FAIL OR OIL STARVATION OCCUR
- ★DRAMATICALLY EXTENDS VALVE SPRING LIFE
- ★SOLD IN 16 OUNCE CANS



**PART  
#PBM 1600**

## ALCOHOL LUBE

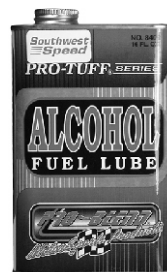

- ★ABSOLUTE FINEST FOR ALL ENGINES BURNING ALCOHOL (METHANOL)
- ★ELIMINATES CHALKING, POWDERING, ETCHING, AND LINE CLOGGING
- ★LUBRICATES ENTIRE FUEL SYSTEM
- ★MIX 16 OUNCES WITH 50 GALLONS OF FUEL
- ★SOLD IN 16 OUNCE CANS

**PART  
#PBM 8400**

Place your order at (479) 646-6988, Fax to (479) 646-5939, or visit [www.southwestspeed.com](http://www.southwestspeed.com)

## MAG 1 MOTOR OIL

- ★MAG 1 MOTOR OIL MEETS THE NEEDS OF ALL RACING & EVERYDAY PASSENGER CAR APPLICATIONS
- ★IT IS SPECIALLY FORMULATED TO EXCEED THE TOUGHEST U.S. STANDARDS FOR OUTSTANDING PROTECTION & PERFORMANCE



DESCRIPTION	PART #
MAG 1 - 10W30 MOTOR OIL, 1 QUART	940-038
MAG 1 - 30 "HEAVY-DUTY" OIL, 1 QT.	940-035
MAG 1 - 30 "HEAVY-DUTY" OIL, 1 GAL.	940-0352

## MAG 1 GEAR OIL

- ★EXCEEDS PERFORMANCE STANDARDS OF THE AUTOMOTIVE PERFORMANCE INDUSTRY
- ★AVAILABLE IN 80W90 & 85W140
- ★AVAILABLE IN QUARTS & GALLONS



DESCRIPTION	PART #
GEAR OIL, 80W90, 1 QUART	940-055
GEAR OIL, 85W140, 1 QUART	940-057
GEAR OIL, 80W90, 1 GALLON	940-060

## MAG 1 HEAVY DUTY WHEEL BEARING GREASE

- ★MAG 1 WHEEL BEARING GREASE IS VIRTUALLY WASH-OUT PROOF & CUSTOM-DESIGNED TO EXTEND BEARING LIFE WITH HIGH TEMPERATURE PROTECTION
- ★SOLD IN 1 LB. TUBS



**PART #940-063**

## MAG 1 POWER STEERING FLUID

- ★PREMIUM QUALITY FLUID
- ★HELPS STOP SQUEALS & MINOR LEAKS
- ★RESTORES SMOOTH OPERATION



DESCRIPTION	PART #
POWER STEERING FLUID, 12 OUNCE	940-050
POWER STEERING FLUID, 32 OUNCE	940-052

## MAG 1 TRANSMISSION FLUID

- ★PREMIUM QUALITY EXCEEDS PERFORMANCE REQUIREMENTS FOR MOST TRANSMISSIONS
- ★AVAILABLE FOR FORD & CHEVY



DESCRIPTION	PART #
DEXRON III FOR CHEVY, 1 QUART	940-065
TYPE F FOR FORD, 1 QUART	940-066

## MAG 1 PENETRATING OIL

- ★LUBRICATES
- ★LOOSENS RUSTED PARTS
- ★DISPLACES MOISTURE
- ★STOPS SQUEAKS
- ★SOLD IN 16 OUNCE SPRAY CANS

**PART #940-049**



## K&W BLOCK SEALER

**PART #940-004**

- ★REPAIRS SMALL CRACKS IN ENGINE BLOCKS & HEADS, AND SEALS SMALL LEAKS IN THE COOLING SYSTEM
- ★SOLD IN 16 OUNCE CANS



## ENGINE BLOCK PLUG KIT

- ★20 PIECE KIT FOR SMALL BLOCK CHEVY BLOCKS



**PART #400-100**

## COOLING SYSTEM STOP LEAK

- ★REPAIRS SMALL HOLES IN RADIATOR
- ★STOPS MOST MINOR LEAKS IN THE COOLING SYSTEM FAST
- ★CONTAINS NO METAL
- ★SOLD IN 12 OUNCE BOTTLES



**PART #940-020**

## WILWOOD DOT 3 BRAKE FLUID

- ★RACING QUALITY
- ★HIGH TEMPERATURE
- ★570 DRY BOILING POINT
- ★DOT 3 NON-SILICON
- ★COMES IN 12 OUNCE BOTTLES



DESCRIPTION	PART #
12 OZ. BOTTLE	WIL 290-0632
24 - 12 OZ. BOTTLES (CASE)	WIL 290-0633

## MAG 1 DOT 3 BRAKE FLUID

- ★EXCEEDS THE HIGHEST STANDARDS OF PERFORMANCE AND SAFETY FOR DOT 3 FLUID
- ★SOLD IN 12 OUNCE BOTTLES



**PART #940-010**

## AIR FILTER OIL

- ★SPRAY-ON RED AEROSOL OIL
- ★HELPS COLLECT THE DIRT ON THE FILTER
- ★COMES IN 12OZ. CANS



DESCRIPTION	PART #
AIR FILTER OIL, 12 OUNCE CAN	411-381
AIR FILTER OIL, CASE OF 12 CANS	411-3811

Place your order at (479) 646-6988, Fax to (479) 646-5939, or visit [www.southwestspeed.com](http://www.southwestspeed.com)



# SCENTED ALCOHOL LUBE

- ★SPECIALLY FORMULATED FOR METHANOL USE
- ★QUICKLY REDUCES FRICTION & PROTECTS AGAINST THE CORROSION ASSOCIATED WITH USING METHANOL
- ★THE VERSIONS OFFERED VARY IN COLOR & SCENT, BUT OFFER THE SAME LUBRICATING PROPERTIES
- ★EACH 16 OUNCE BOTTLE TREATS 55 GALLONS OF METHANOL
- ★CAN BE USED IN CONJUNCTION WITH A BOTTLE OF SCENTED FUEL FRAGRANCE FOR A STRONGER SMELL



DESCRIPTION	PART #
TOP LUBE, CHERRY SCENT	MHO 19769-00018
TOP LUBE, GRAPE SCENT	MHO 19769-00031
TOP LUBE, STRAWBERRY SCNT.	MHO 19769-00035

\*CHECK [www.southwestspeed.com](http://www.southwestspeed.com) FOR OTHER SCENTS THAT BECOME AVAILABLE

# FUEL FRAGRANCES

- ★CAN BE USED IN GAS, METHANOL, & DIESEL
- ★WIDELY USED IN ALL MOTORIZED VEHICLES
- ★INTENDED TO SET YOU APART FROM THE REST
- ★DOESN'T ENHANCE OR INHIBIT PERFORMANCE & IS SAFE TO USE IN ALL INTERNAL COMBUSTION ENGINES
- ★FOR BEST RESULTS, USE IN VEHICLES WITHOUT CATALYTIC CONVERTERS
- ★4 OUNCE BOTTLE TREATS 10-20 GAL. OF GAS, 30-55 GAL OF METHANOL, & 5-10 GAL. OF DIESEL



DESCRIPTION	PART #
FRAGRANCE, CHERRY	MHO 19769-00019
FRAGRANCE, GRAPE	MHO 19769-00032
FRAGRANCE, STRAWBERRY	MHO 19769-00036
FRAGRANCE, BUBBLE GUM	MHO 19769-00044
FRAGRANCE, PINA COLADA	MHO 19769-00047
FRAGRANCE, COTTON CANDY	MHO 19769-00049

\*CHECK [www.southwestspeed.com](http://www.southwestspeed.com) FOR OTHER SCENTS THAT BECOME AVAILABLE

# 8" WIDE SOUTHWEST SPEED RACING TIRE

- ★SOUTHWEST SPEED IS ALWAYS LOOKING TO KEEP THE COST OF RACING DOWN
- ★WITH LOWER COST, BETTER WEAR, & COMPETITIVE SPEED, THE \$69.99 SOUTHWEST SPEED TIRE IS ENGINEERED & DESIGNED WITH THAT SPECIFIC GOAL IN MIND
- ★26.0" x 8.0" x 15", 60 COMPOUND
- ★COMPETITIVE WITH OTHER BRANDS OF 8" WIDE TIRES WITH SUBSTANTIALLY LESS WEAR & COST
- ★IN SOME CASES, THE SOUTHWEST SPEED TIRE IS LASTING 4-5 TIMES AS LONG AS OTHER BRANDS
- ★GREAT FOR USE IN ANY CLASS THAT RUNS AN 8" WIDE TIRE: MODIFIEDS, ECONOMY MODIFIEDS, LIMITED LATE MODELS, MINI-STOCKS, HOBBY STOCKS, FACTORY STOCKS, LEGENDS, ETC.
- ★WHY RUN A \$85-100 TIRE THAT WILL WEAR OUT IN 1 NIGHT, WHEN YOU CAN RUN A \$69.99 TIRE THAT WILL LAST 4 TO 5 TIMES THAT LONG?

**\$69.99**



**PART #299-499**



# TRIPLE X CHASSIS & KITS

#XXX SCCH 100087

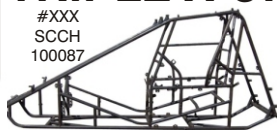

#XXX SCCH100287 SPRINT CAR CHASSIS KIT "A"

- ★CHASSIS ARE MADE FROM HIGH-GRADE 4130 CHROMOLY TUBING THAT IS PRE-TESTED FOR CHEMICAL COMPOSITION, HARDNESS, & STRENGTH
- ★THE TRIPLE X CHASSIS HAS THE SAME DESIGN AS ALMOST ALL OTHER CHASSIS ON THE MARKET, INCLUDING THE EXACT PICKUP POINTS, MOTOR PLATE & TORSION TUBE LOCATIONS, ETC
- ★CHASSIS KIT B INCLUDES BODY & TIN WORK
- ★SPRINT CAR KIT A INCLUDES BODY, TIN, BUMPERS & NERF BARS, MOTOR PLATE, FRONT END, & MUCH OF THE STEERING, & MUCH OF THE SUSPENSION
- ★MIDGET "RACER" KIT INCLUDES BODY, TIN, BUMPERS, NERF BARS, TORSION ARMS & STOPS, PEDALS, FRONT AXLE, SUSPENSION RODS, DRAG LINK, TIE ROD, & PITMAN ARM
- ★600 MICRO "RACER" KIT INCLUDES BODY, TIN, BUMPERS, NERF BARS, TORSION ARMS & STOPS, AND FRONT AXLE
- ★600 "SUPER DELUXE" KIT INCLUDES THE ITEMS IN THE "RACER" KIT, PLUS THE MAJORITY OF ITEMS FOR SUSPENSION, STEERING, FRONT END, REAR END, DRIVELINE, BRAKES, ENGINE, & WING MOUNTING THAT'S NEEDED TO GO RACING

SPRINT CAR	PART #
BARE CHASSIS, 87/40	XXX SCCH100087
BARE CHASSIS, 87/40, 2" TALLER	XXX SCCH1000872
BARE CHASSIS, 88/40	XXX SCCH100088
BARE CHASSIS, 88/40, 2" TALLER	XXX SCCH1000882
CHASSIS KIT B, 87/40	XXX SCCH100187
CHASSIS KIT B, 87/40, 2" TALLER	XXX SCCH1001872
CHASSIS KIT B, 88/40	XXX SCCH100188
CHASSIS KIT B, 88/40, 2" TALLER	XXX SCCH1001882
CHASSIS KIT A, 87/40	XXX SCCH100287
CHASSIS KIT A, 87/40, 2" TALLER	XXX SCCH1002872
CHASSIS KIT A, 88/40	XXX SCCH100288
CHASSIS KIT A, 88/40, 2" TALLER	XXX SCCH1002882
MIDGET	PART #
BARE CHASSIS	XXX MDCH1000
CHASSIS KIT B	XXX MDCH1001
"RACER" CHASSIS KIT	XXX MDCH1002
600 MICRO-SPRINT	PART #
BARE CHASSIS	XXX 600CH1000
CHASSIS KIT B	XXX 600CH1001
"RACER" CHASSIS KIT	XXX 600CH1002
"SUPER DELUXE" CHASSIS KIT	XXX 600CH1008

Place your order at (479) 646-6988, Fax to (479) 646-5939, or visit [www.southwestspeed.com](http://www.southwestspeed.com)

# SOUTHWEST SPEED MOTORCOACHES

## BRAND NEW 330 PETERBILTS WITH 300 H.P. CATERPILLAR ENGINES

- ★MOTORHOMES ARE ALL BRAND NEW
- ★EACH MOTORHOME FEATURES 3126 SERIES, 300 HORSEPOWER, CATERPILLAR ENGINE. EATON/FULLER SUPER 10 SPEED TRANSMISSION. AIR RIDE/AIR TRAC SUSPENSION. ALCOA POLISHED ALUMINUM WHEELS. 22.5" BRIDGESTONE TIRES. PETERBILT VANTAGE INTERIOR GROUP. AIR RIDE SEATS. TILT/TELESCOPING STEERING COLUMN. CRUISE CONTROL. AM/FM CASSETTE STEREOS. HEATED MOTO-MIRRORS. 120 GALLON DIESEL FUEL. AIR ASSISTED PINDLE HITCH. AIR BRAKE OUTLETS. GLAD HANDS. LARGE FULL SIZE SHOWER & BATHROOM. 20 GALLON HOT WATER. 100 GALLON FRESH WATER. 100 GALLON HOLDING TANKS.
- ★EACH MOTORHOME IS LOADED WITH CABINETS AND CLOSETS. SLEEPS AND RIDES 8 ADULTS. 4 BUNKS. LARGE OVER CAB LOFT SLEEPS 2. FOLD OUT COUCH. PRIVACY POCKET DOORS THROUGHOUT. CENTRAL VACUUM. 2 BURNER COOKTOP RANGE. MICROWAVE OVEN. FULL SIZE REFRIGERATOR. AM/FM CASSETTE/CD PLAYERS. TELEVISION/VCR COMBO WITH REMOTE AND ROAD RANGER ANTENNA. MOTORHOME SIDE DOOR WITH SCREEN DOOR. PORCH LIGHT WITH LIGHTED ENTRY HANDLE. 12 VOLT LIGHTING THROUGHOUT WITH SEPARATE STORAGE BATTERIES AND INVERTER. AUTOMATIC STARTING 10,000 KW DIESEL GENERATOR WITH BATTERY CHARGING CAPABILITIES. RV REMOTE HOOKUPS INSTALLED. SHORE POWER INLET. TRAILER POWER OUTLETS. CENTRAL HEAT AND AIR WITH DIGITAL ELECTRONIC CONTROLS. LOTS OF LARGE LOCKING EXTERNAL STORAGE WITH SWING-UP DOORS ON EACH COMPARTMENT. PLUMBING IS IN SUB-FLOOR TO ALLOW MOTORHOMES TO BE OPERATED IN COLD WEATHER. MOTORHOMES ARE WHITE IN COLOR.
- ★MOTORHOMES HAVE NEVER BEEN TITLED AND PURCHASER WILL BE THE ORIGINAL OWNER. PLEASE CALL SOUTHWEST SPEED WITH ANY QUESTIONS OR INQUIRES, (479) 646-6988.



Place your order at (479) 646-6988, Fax to (479) 646-5939, or visit [www.southwestspeed.com](http://www.southwestspeed.com)



# SOUTHWEST SPEED TRAILERS

★CAN BE SOLD SEPARATELY OR AS ONE UNIT WITH A MOTORCOACH

★EACH TRAILER IS A BRAND NEW STACKER. WILL EASILY HOLD 2 CARS WITH PLENTY OF ROOM FOR CABINETS IN THE FRONT. TOTAL DIMENSIONS: 13.6' TALL X 102" WIDE WITH 11.2' INSIDE CEILING HEIGHT, 96" BETWEEN THE WALLS, & 81" BETWEEN THE FENDER WELLS. 4' WIDE X 7.2' TALL, EXTRA-LARGE SIDE ENTRY DOOR WITH STAINLESS STEEL PIANO HINGE. 7.2' TALL X 97" WIDE REAR RAMP DOOR WITH 4500 LB. CAPACITY & LOCKING, STAINLESS STEEL SWIVEL HANDLES. WHITE, .030" ALUMINUM INTERIOR WALLS, FULLY FINISHED. EASY-CLEAN VINYL FLOOR. 16" O.C. WALL MOUNTS. 50 AMP POWER BOX WITH LIFE LINE CABLE. INCLUDES 2 BATTERIES WITH CHARGER. 2 - 12 VOLT DOME LIGHTS. COMPLETE 110 VOLT ELECTRIC PACKAGE WITH 2 - SIDE 500 WALL QUARTZ LIGHTS, 2 - RAMP DOOR LIGHTS, AND 3 - 4' DUAL FLOURESCENT LIGHTS. STINGER 13' GENERATION 2 LIFT WITH REMOTE PACKAGE & TIE-DOWN PACKAGE FOR BOTH CARS. NEW STYLE ALUMINUM END CASTING. STAINLESS STEEL FRONT CAP. SEAMLESS ALUMINUM ROOF. NEW STYLE ROOF EXTRUSION. TRIPLE DEXTER, 6200 LB. AXLES WITH ELECTRIC BRAKES. TRIPLE TUBE, 60" HEAVY-DUTY TONGUE WITH 6" PINTLE HOOK. 8" I-BEAM FRAME. 48" REAR BEAVERTAIL. 16" WHEELS WITH STAINLESS CENTER CAPS. ALUMINUM FENDERS.

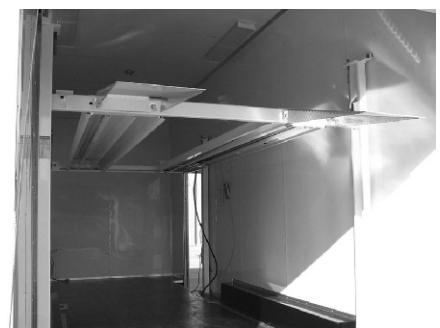

Place your order at (479) 646-6988, Fax to (479) 646-5939, or visit [www.southwestspeed.com](http://www.southwestspeed.com)



# SOUTHWEST SPEED PRICING

DUE TO THE FACT THAT PRICES ARE CONSISTENTLY CHANGING THESE DAYS, WE HAVEN'T INCLUDED A PRICESHEET IN THIS CATALOG. ALL PRICES ARE UP-TO-THE-SECOND ON OUR WEBSITE ON EACH & EVERY ITEM, [www.southwestspeed.com](http://www.southwestspeed.com)

ALSO, YOU CAN DOWNLOAD A PRICESHEET BY GOING TO [www.southwestspeed.com/prices](http://www.southwestspeed.com/prices)

IN ADDITION, UPON REQUEST, WE WILL BE GLAD TO MAIL YOU A HARD PRICESHEET OR A PRICESHEET ON A CD. WE CAN ALSO SIMPLY EMAIL YOU A PRICESHEET. ALSO, FEEL FREE TO HAVE THE PRICES QUOTED OVER THE PHONE AT THE TIME OF ORDERING

## SOUTHWEST SPEED T-SHIRTS

- ★HIGH QUALITY, WHITE COTTON T-SHIRTS
- ★GRAPHICS ON BOTH FRONT & BACK
- ★AVAILABLE SMALL TO 3XL



DESCRIPTION	PART #
SWS T-SHIRT, SMALL	999-952
SWS T-SHIRT, MEDIUM	999-953
SWS T-SHIRT, LARGE	999-954
SWS T-SHIRT, X-LARGE	999-955
SWS T-SHIRT, XX-LARGE	999-956
SWS T-SHIRT, XXX-LARGE	999-957

## SOUTHWEST SPEED GIFT CERTIFICATES

- ★BIRTHDAY, CHRISTMAS, FATHERS DAY, MOTHERS DAY, OR ANY OCCASION, WHAT BETTER WAY TO FEED A RACING ADDICTION THAN WITH A SOUTHWEST SPEED GIFT CERTIFICATE
- ★AVAILABLE YEAR-ROUND FOR ANY DOLLAR AMOUNT



[www.southwestspeed.com](http://www.southwestspeed.com)



Place your order at (479) 646-6988, Fax to (479) 646-5939, or visit [www.southwestspeed.com](http://www.southwestspeed.com)



## Southwest Speed

7423 Hwy. 271 South  
Fort Smith, AR 72908  
(479) 646-6988  
www.southwestspeed.com

PRSRST STD  
U.S. POSTAGE  
**PAID**  
FORT SMITH, AR  
PERMIT NO. 396



Order online with  
up-to-the-second  
pricing at  
southwestspeed.com  
24 hours a day  
7 days a week

Call us at: (479) 646-6988  
www.southwestspeed.com