

**ASSEMBLY INSTRUCTIONS**  
FOR  
**DYNALITE BIG BRAKE FRONT HUB KIT**  
**WITH 12.19" DIAMETER VENTED ROTOR**

**1955 - 1957 CHEVROLET**

PART NUMBER GROUP

**140-7676**

**DISC BRAKES SHOULD ONLY BE INSTALLED BY SOMEONE  
EXPERIENCED AND COMPETENT IN THE INSTALLATION  
AND MAINTENANCE OF DISC BRAKES**

**READ ALL WARNINGS**

**WARNING**

IT IS THE RESPONSIBILITY OF THE PERSON INSTALLING ANY BRAKE COMPONENT OR KIT TO DETERMINE THE SUITABILITY OF THE COMPONENT OR KIT FOR THAT PARTICULAR APPLICATION. IF YOU ARE NOT SURE HOW TO SAFELY USE THIS BRAKE COMPONENT OR KIT, YOU SHOULD NOT INSTALL OR USE IT. DO NOT ASSUME ANYTHING. IMPROPERLY INSTALLED OR MAINTAINED BRAKES ARE DANGEROUS. IF YOU ARE NOT SURE, GET HELP OR RETURN THE PRODUCT. YOU MAY OBTAIN ADDITIONAL INFORMATION AND TECHNICAL SUPPORT BY CALLING WILWOOD AT (805) 388-1188, OR VISIT OUR WEB SITE AT [WWW.WILWOOD.COM](http://WWW.WILWOOD.COM). USE OF WILWOOD TECHNICAL SUPPORT DOES NOT GUARANTEE PROPER INSTALLATION. YOU, OR THE PERSON WHO DOES THE INSTALLATION MUST KNOW HOW TO PROPERLY USE THIS PRODUCT. IT IS NOT POSSIBLE OVER THE PHONE TO UNDERSTAND OR FORESEE ALL THE ISSUES THAT MIGHT ARISE IN YOUR INSTALLATION.

RACING EQUIPMENT AND BRAKES MUST BE MAINTAINED AND SHOULD BE CHECKED REGULARLY FOR FATIGUE, DAMAGE, AND WEAR.



**WARNING**

**DO NOT OPERATE ANY VEHICLE ON UNTESTED BRAKES!**  
**SEE MINIMUM TEST PROCEDURE WITHIN**

**ALWAYS** UTILIZE SAFETY RESTRAINT SYSTEMS AND ALL OTHER AVAILABLE SAFETY EQUIPMENT WHILE OPERATING THE VEHICLE.

**IMPORTANT • READ THE DISCLAIMER OF WARRANTY INCLUDED IN THE KIT.**

NOTE: Some cleaners may stain or remove the finish on brake system components. Test the cleaner on a hidden portion of the component before general use.

## Important Notice - Read This First

Before any tear-down or disassembly begins, review the following information:

- Review the wheel clearance diagram (figure 2, page 3) to verify that there is adequate clearance with the wheels you will be using with the installation.
- Front brake kits do not include flex lines. OEM brake lines will not adapt to Wilwood calipers. Check the assembly instructions, or associated components section for brake line recommendations before assembly. In addition, Wilwood offers an extensive listing of brake lines and fitting on our web site: [www.wilwood.com](http://www.wilwood.com).
- Due to OEM production differences and other variations from vehicle to vehicle, the fastener hardware and other components in this kit may not be suitable for a specific application or vehicle.
- It is the responsibility of the purchaser and installer of this kit to verify suitability / fitment of all components and ensure all fasteners and hardware achieve complete and proper engagement. Improper or inadequate engagement can lead to component failure.

## Exploded Assembly Diagram

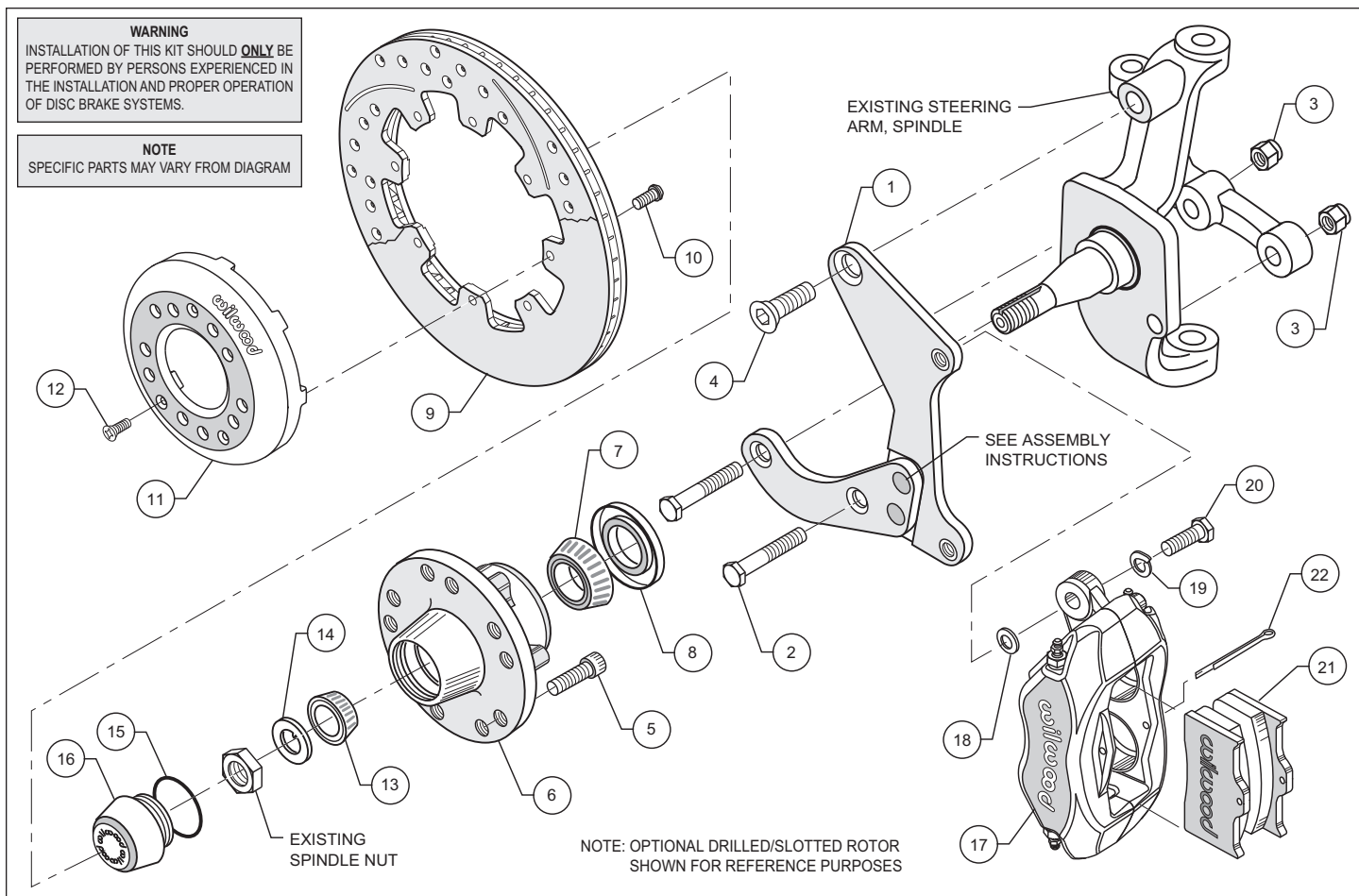

Figure 1. Typical Installation Configuration

## Parts List

ITEM NO.	PART NO.	DESCRIPTION	QTY
1	249-7637/38	Brackets, Caliper Mounting (pair, one each, left and right)	2
2	230-10426	Bolt, 7/16-20 x 2.50 Long, Hex Head	4
3	230-3760	Nut, Oval Lock 7/16-20	4
4	230-10421	Bolt, 5/8-18 x 1.12 Long	2
5	230-6959	Stud, Wheel, 1/2-20 x 2.00 Long	10
6	270-7631	Hub Assembly	2
7	370-0879	Cone, Inner Bearing	2
8	380-0928	Seal, Grease	2
9	160-5843	Rotor, .81" Thick x 12.19" Dia, 8 x 7.00" Bolt Circle	2
9A	160-7103/04	Rotor, Drilled and Slotted (pair, one each, left and right)	2
10	230-2043	Bolt, 5/16-18 x 0.75 Long, Hex Head	16
11	170-7632	Hat	2
12	230-10419	Bolt, 1/4-20 x 0.50 Long, FHCS	6
13	370-0877	Cone, Outer Bearing	2
14	240-2283	Washer, Spindle, 3/4	2
15	211-1674	O-ring	2
16	270-2158	Cap, Dust	2
17	120-6816	Caliper, Forged Dynalite	2
18	240-1159	Washer, Shim, 3/8	12
19	240-0140	Washer, Lock, 3/8	4
20	230-0228	Bolt, 3/8-24 x 1.25 Long, Hex Head	4
21	150-8850K	Pad, BP-10, Axle Set	1
22	180-0055S	Pin, Cotter	2

NOTES: Part Number 230-7698 Bolt Kit, bracket bolt kit, includes part numbers 230-10426, 230-3760 and 230-10421  
 Part Number 230-7032 Bolt Kit, hat to hub, includes part numbers 230-10419  
 Part Number 230-3484 Bolt Kit, rotor to hat, includes part number 230-2043  
 Part Number 230-0204 Bolt Kit, caliper to bracket, includes part numbers 230-0228, 240-0140 and 240-1159  
 Item 9A is an optional item and is available in the (D) drilled kits

## General Information and Disassembly Instructions

Installation of this kit should **ONLY** be performed by persons experienced in the installation and proper operation of disc brake systems. Before assembling the Wilwood front disc brake kit, double check the following items to ensure a trouble-free installation.

- Make sure this is the correct kit to match the exact make and model year of the vehicles spindle (i.e., hubs for a 1955 Chevrolet spindle will not fit a 1982 spindle).
- Verify the hub stud pattern in this kit (5 x 4.50 or 5 x 4.75) matches the stud pattern of the vehicles wheels.
- Verify wheel clearance, see Figure 2.
- Inspect the package contents against the parts list to ensure that all components and hardware are included.

### Disassembly Instructions:

- Disassemble the original equipment front brakes:

Raise the front wheels off the ground. Support the front suspension by placing jack stands under the lower control arms. The lower control arms **MUST** be supported. The vehicle's weight must be on jack stands and not supported by a car jack or hoist.

Remove the center cap, cotter pin, nut lock and the wheel bearing nut and washer. Save the wheel bearing nut and nut lock. Remove the brake drum and hub assembly, including the wheel bearings. Disconnect the brake hoses from the brake line at the body. Remove the two upper backing plate retaining nuts and bolts. Remove the two lower ball joint to spindle nuts and bolts. The backing plate, spindle and ball joint will now separate. Remove the brake backing plate and shoes as an assembly. Reinstall the front ball joint bolt and nut. Do not tighten at this time. Do not reinstall the rear bolt and nut.

- Clean and de-grease the spindles.

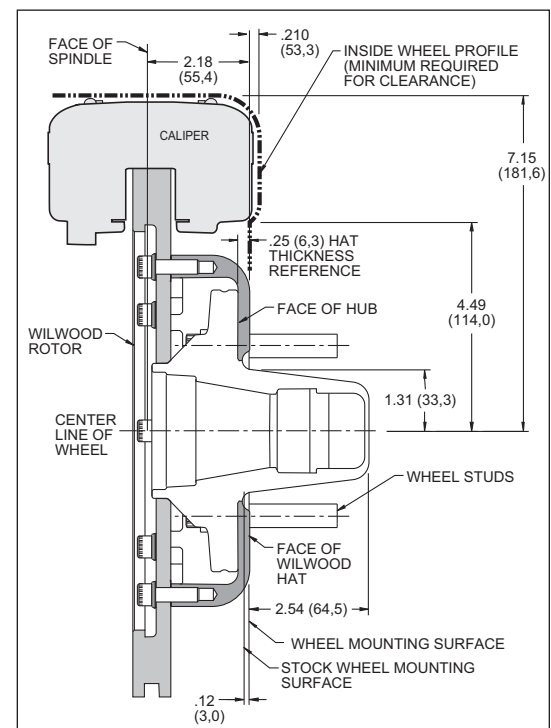

Figure 2. Wheel Clearance Diagram

## Assembly Instructions

**Assembly Instructions** (numbers in parenthesis refer to the part list/diagram on the preceding page): **CAUTION:** All mounting bolts must fully engage insert nuts. Be sure to check that all bolts are either flush or protruding through flanged side of insert nut after shimming.

- The spindle and caliper bracket (1) have been assembled at the factory for alignment purposes. Loosen the two bolts that secure the brackets together so that the bolts are hand tight only, this will enable the bracket assembly (1) to be adjusted to accommodate various spindle tolerances during assembly. Bolt the lower portion of the bracket assembly (1) to the backing plate face of the spindle using two bolts (2) and two lock nuts (3), hand tighten only. **NOTE:** Be sure the heads of the bracket assembly (1) insert nuts are facing outward toward the wheel. Install bolt (4) through caliper bracket (1), and into the steering arm. Torque two bolts (2) to 47 ft-lb. Apply red *Loctite*® 271 to the bolt threads (4) and torque to 140 ft-lb. Remove one of the bolts that secure the bracket assembly (1) to each other. Apply red *Loctite*® 271 to the bolt threads and reinsert into the bracket assembly. Repeat this procedure for the second bolt. Torque these two bolts to 30 ft-lb.
- Install five new wheel studs (5) into the hub (6). Torque to 77 ft-lb. **NOTE:** There are two five lug patterns in the hub (5 x 4.50 and 5 x 4.75). Make sure of the correct hole pattern for the correct wheel application before installing studs into hub.
- Pack the large inner bearing cone (7) with high temperature disc brake bearing grease (available from your local auto parts store) and install into the backside of the hub (6).
- Install the grease seal (8) by pressing into the backside of the hub (6).
- Pack the small outer bearing cone (13) with high temperature disc brake bearing grease and install into the front side of the hub (6). Lightly coat the spindle bearing surfaces with bearing grease. Slide the hub assembly (5, 6, 7, 8 and 13) onto the spindle. Secure using spindle washer (14), existing adjusting nut and nut locking device. Adjust wheel bearing pre-load per Original Equipment Manufacturer (OEM) specifications.
- Install the o-ring (15) and the dust cap (16) into the hub (6). Friction created by the o-ring (15) on the dust cap (16) keeps it from unscrewing. The O.D. of the existing spindle washer may be larger than the I.D. of the dust cap (16) which may allow the washer to contact the dust cap (16). Use the spindle washer (14) supplied with the kit instead of the stock washer.
- With the larger I.D. side of the rotor (9) facing away from the hat (11), bolt rotor (9) to hat (11) through the backside of the rotor using bolts (10). Torque bolts (10) to 180 **in-lb**. Safety wire bolts (10) using standard 0.032 inch diameter stainless steel safety wire as shown in Figure 3. Please refer to Wilwood's data sheet DS-386 (available at [www.wilwood.org/ds386.pdf](http://www.wilwood.org/ds386.pdf)) for complete safety wire installation instructions.
- Slide the rotor/hat assembly (9, 10 and 11) over the wheel studs (5) in the hub (6) taking care to align the small countersunk holes in the hat (11) with the small threaded holes in the hub (6) Install three flat head socket head screws (12) through the small holes in the hat (11) and torque to 100 **in-lb**.
- NOTE:** Please reference the caution statement at the beginning of the assembly instructions. With the bleed screws pointing up, mount the caliper (17) onto the caliper bracket (1) using two bolts (20), two lock washers (19) and two shim washers (18). Finger tighten. View the rotor (9) through the top of the caliper (17). The rotor (9) should be aligned in the center of the caliper (17). If not, loosen the two bolts (20) and adjust the caliper (17) by using 0.032 inch thick shim washers (18). The shim washers (18) should be placed between the caliper (17) and the caliper bracket (1). Finger tighten and recheck alignment. Loosen the two bolts (20) and apply red *Loctite*® 271 to bolt threads (20) and torque to 30 ft-lb. Safety wire the two bolts (20).
- Install the disc brake pads (21) into the caliper (17) and secure using cotter pin (24).
- NOTE:** OEM rubber brake hoses generally cannot be adapted to Wilwood calipers. The caliper inlet fitting is a 1/8-27 NPT. The preferred method is to use steel adapter fittings at the caliper, either straight, 45 or 90 degree and enough steel braided line to allow for full suspension travel and turning radius, lock to lock. **Carefully route lines to prevent contact with moving suspension, brake or wheel components.** Wilwood hose kits are designed for use in many different vehicle applications and it is the installer's responsibility to properly route and ensure adequate clearance and retention for brake hose components. Wilwood offers a hose kit, P/N 220-7699, which includes hoses, fittings, etc., all in one package for this application.
- Specified brake hose kits may not work with all Years, Makes and Models of vehicle that this brake kit is applicable to, due to possible OEM manufacturing changes during a production vehicle's life. It is the installer's responsibility to ensure that all fittings and hoses are the correct size and length, to ensure proper sealing and that they will not be subject to crimping, strain and abrasion from vibration or interference with suspension components, brake rotor or wheel.

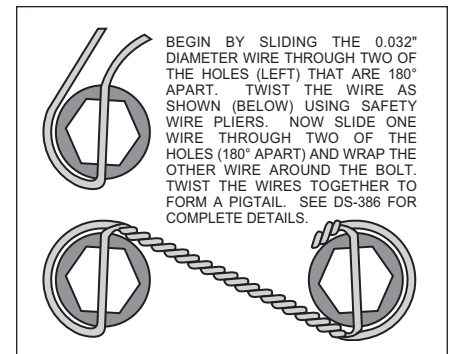

Figure 3. Safety Wire Diagram

## Assembly Instructions (Continued)

- In absence of specific instructions for brake line routing, the installer must use his best professional judgment on correct routing and retention of lines to ensure safe operation. Test vehicle brake system per the 'minimum test' procedure stated within this document before driving. After road testing, inspect for leaks and interference. Initially after install and testing, perform frequent checks of the vehicle brake system and lines before driving, to confirm that there is no undue wear or interference not apparent from the initial test. Afterwards, perform periodic inspections for function, leaks and wear in a interval relative to the usage of vehicle.
- Bleed the brake system. Reference the general information and recommendations on the last page for proper bleeding instructions.
- Repeat assembly procedure for the other wheel.

## Balancing the Brake Bias on 4 Wheel Disc Vehicles

### •OE Style or Single Mount Race Pedal with Tandem Outlet Master Cylinder:

Front to rear caliper piston sizes, rotor diameters, and pad compounds must be initially configured to provide the correct range of vehicle bias when using a single bore / tandem outlet master cylinder. If excessive rear brake bias is experienced, an inline adjustable proportioning valve can be used to decrease the rear line pressure to help bring the vehicle into balance. If excessive front brake bias is experienced, first consideration should be given to increasing the rear brake bias to bring the vehicle into overall balance.

### •Race Pedal with Dual Master Cylinders and Balance Bar:

Master cylinders must be sized to match the calipers and allow the pedal balance bar to operate near the center of its travel. If it is not possible to fine tune the bias within the adjustable range of the balance bar, then consideration must be given to changing a master cylinder bore size or some other aspect of the brake system to bring the car into balance. Larger bore master cylinders will generate less pressure while decreasing pedal travel. Smaller bores master cylinders will generate higher line pressures with an increase in pedal travel.

## Additional Information and Recommendations

- Fill and bleed the new system with Wilwood Hi-Temp<sup>®</sup> 570 grade fluid or higher. For severe braking or sustained high heat operation, use Wilwood EXP 600 Plus Racing Brake Fluid. Used fluid must be completely flushed from the system to prevent contamination.  
**NOTE:** Silicone DOT 5 brake fluid is **NOT** recommended.
- To properly bleed the brake system, begin with the caliper farthest from the master cylinder. Bleed the outboard bleed screw first, then the inboard. Repeat the procedure until all calipers in the system are bled, ending with the caliper closest to the master cylinder.  
**NOTE:** When using a new master cylinder, it is important to bench bleed the master cylinder first.
- If the master cylinder is mounted lower than the disc brake calipers, some fluid flowback to the master cylinder reservoir may occur, creating a vacuum effect that retracts the caliper pistons into the housing. This will cause the pedal to go to the floor on the first stroke until it has "pumped up" and moved all the pistons out against the pad again. A Wilwood in-line two pound residual pressure valve, installed near the master cylinder will stop the fluid flowback and keep the pedal firm and responsive.
- Test the brake pedal. It should be firm, not spongy and stop at least 1 inch from the floor under heavy load.
  - If the brake pedal is spongy, bleed the system again.
  - If the brake pedal is initially firm, but then sinks to the floor, check the system for fluid leaks. Correct the leaks (if applicable) and then bleed the system again.
  - If the brake pedal goes to the floor and continued bleeding of the system does not correct the problem, a master cylinder with increased capacity (larger bore diameter) will be required. Wilwood offers various lightweight master cylinders with large fluid displacement capacities.
- **NOTE:** With the installation of after market disc brakes, the wheel track may change depending on the application. Check your wheel offset before final assembly.
- On some models of disc brake spindles there are "ears" where the OEM calipers were mounted and these "ears" interfere with the assembly of the Wilwood disc brake kit. If it becomes necessary to remove these "ears", remove as little as possible being careful not to cut away any of the mounting holes that may be required to bolt on the caliper mounting bracket.
- If after following the instructions, you still have difficulty in assembling or bleeding your Wilwood disc brakes, consult your local chassis builder, or retailer where the kit was purchased for further assistance.

## Brake Testing and Pad Bedding

### **WARNING • DO NOT DRIVE ON UNTESTED BRAKES BRAKES MUST BE TESTED AFTER INSTALLATION OR MAINTENANCE MINIMUM TEST PROCEDURE**

- Make sure pedal is firm: Hold firm pressure on pedal for several minutes, it should remain in position without sinking. If pedal sinks toward floor, check system for fluid leaks. DO NOT drive vehicle if pedal does not stay firm or can be pushed to the floor with normal pressure.
- At very low speed (2-5 mph) apply brakes hard several times while turning steering from full left to full right, repeat several times. Remove the wheels and check that components are not touching, rubbing, or leaking.
- Carefully examine all brake components, brake lines, and fittings for leaks and interference.
- Make sure there is no interference with wheels or suspension components.
- Drive vehicle at low speed (15-20 mph) making moderate and hard stops. Brakes should feel normal and positive. Again check for leaks and interference.
- Always test vehicle in a safe place where there is no danger to (or from) other people or vehicles.
- Always wear seat belts and make use of all safety equipment.

#### **PAD BEDDING PROCEDURE:**

• Pump brakes at low speed to assure proper operation. On the race track, or other safe location, make a series of hard stops until some brake fade is experienced. Allow brakes to cool while driving at moderate speed to avoid use of the brakes. This process will properly burnish the brake pads, offering maximum performance.

### **Associated Components**

<b><u>PART NO.</u></b>	<b><u>DESCRIPTION</u></b>
260-1874	Wilwood Residual Pressure Valve (2 lb for disc brakes)
260-1876	Wilwood Residual Pressure Valve (10 lb for drum brakes)
260-8419	Wilwood Proportioning Valve
290-0632	Wilwood Racing Brake Fluid (Hi-Temp° 570) (12 oz)
290-6209	Wilwood Racing Brake Fluid (EXP 600 Plus) (16.9 oz)
340-1285	Wilwood Floor Mount Brake Pedal (with balance bar)
340-1287	Wilwood Swing Mount Brake Pedal (with balance bar)
260-6764	Wilwood 3/4 inch High Volume Aluminum Master Cylinder
260-6765	Wilwood 7/8 inch High Volume Aluminum Master Cylinder
260-6766	Wilwood 1 inch High Volume Aluminum Master Cylinder
260-4893	1-1/16 inch Tandem Master Cylinder (aluminum housing)
250-2406	Mounting Bracket Kit (tandem master cylinder)
260-8555	Wilwood 1 inch Aluminum Tandem Chamber Master Cylinder
260-8556	Wilwood 1-1/8 inch Aluminum Tandem Chamber Master Cylinder
350-2038	1971 - 1973 Pinto Rack and Pinion (new, not rebuilt)
270-2016	Quick Release Steering Hub (3/4 inch shaft)
270-2017	Quick Release Steering Hub (5/8 inch shaft)
220-7056	Flexline Kit, Universal, 14 Inch, Domestic
220-7699	Flexline Kit, Universal, 16 Inch, Domestic
220-8307	Flexline Kit, Universal, 18 Inch, Domestic